

MINIMAL SOLIDS-HANDLING, MEDIUM-HEAD, ENGINE-DRIVEN SELF-PRIMING CENTRIFUGAL PUMPS

Gorman-Rupp 4" and 6" self-priming, medium-head centrifugal pumps are designed for dewatering applications where large solids-handling capabilities are not required. Pumps are constructed of heavy-duty cast iron with replaceable cast iron impellers and cast iron or carbon steel wear plates. Pumps are available with Deutz or John Deere diesel engines. All models include a suction strainer and 90° discharge elbow.



Model: 84A2-F3L

FEATURES

- Cast iron construction
- Gorman-Rupp double-lubricated grease seals
- 4", 6" or 10" NPT port sizes
- Self-priming up to 25 ft. (7,6 m) lift with built-in flap valve
- Engine options: Deutz or John Deere diesel engine
- Replaceable cast iron impeller and cast iron or steel wearplate
- Solids-handling to 2-1/2" (63 mm)
- Wheel kit or D.O.T. approved trailer available upon request
- Maximum temperature to 110° F (43° C)
- Maximum operating pressure to 141 psi (9,7 bar)



GENERAL INFORMATION

Model	Ship Wt. (Approx.)	Driver Type (HP)	Max. Solids	Suc. x Dis. (NPT)	Basic Construction	Seal Type & Elastomer/Faces	Tank	Run Time	Mounting
84A2-4024H*	2600 lbs.	John Deere Diesel (61.0)	1-1/8" (28 mm)	4" x 4"	Cast Iron	Gorman-Rupp Grease	61.0 gal.	24.4 hrs.	Fuel Tank Base
84A2-F3L*	1893 lbs.	Deutz Diesel (55.0)	1-1/8" (28 mm)	4" x 4"	Cast Iron	Gorman-Rupp Grease	38.9 gal.	17.7 hrs.	Skid Base
86A2-4024H*	2600 lbs.	John Deere Diesel (61.0)	1-15/16" (49 mm)	6" x 6"	Cast Iron	Gorman-Rupp Grease	61.0 gal.	20.3 hrs.	Fuel Tank Base
86A2-F3L*	2185 lbs.	Deutz Diesel (55.0)	1-15/16" (49 mm)	6" x 6"	Cast Iron	Gorman-Rupp Grease	38.9 gal.	21.7 hrs.	Skid Base
86A2-F4L*	2256 lbs.	Deutz Diesel (74.0)	1-15/16" (49 mm)	6" x 6"	Cast Iron	Gorman-Rupp Grease	38.9 gal.	12.4 hrs.	Skid Base
810A2-4045T*	2955 lbs.	John Deere Diesel (74.0)	2-1/2" (63 mm)	10" x 10"	Cast Iron	Gorman-Rupp Grease	88.0 gal.	29.1 hrs.	Fuel Tank Base

*12 volt electric start. Battery not included. *Viton® is a registered trademark of DuPont.

MINIMAL SOLIDS-HANDLING, MEDIUM-HEAD, ENGINE-DRIVEN, SELF-PRIMING CENTRIFUGAL PUMPS

80 SERIES

PERFORMANCE CURVES

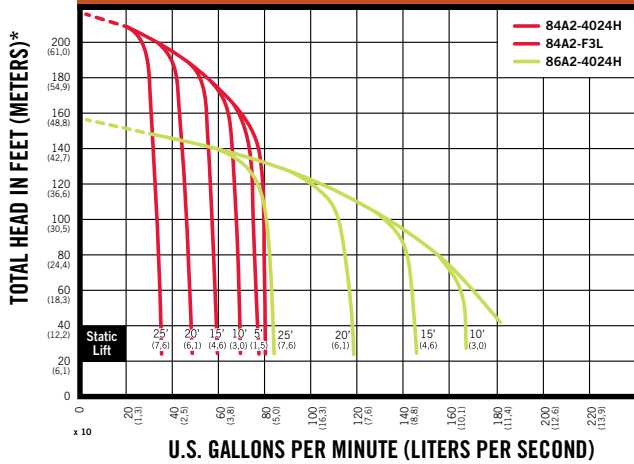

PERFORMANCE CURVES

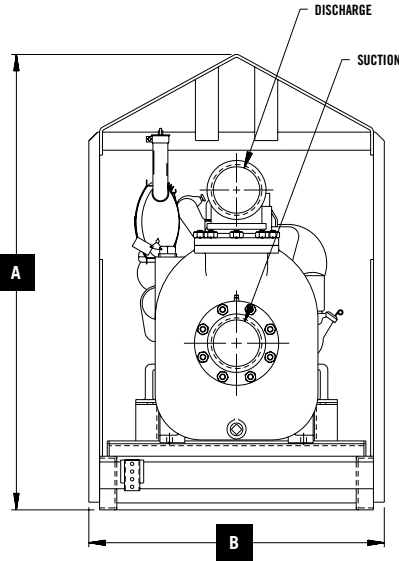
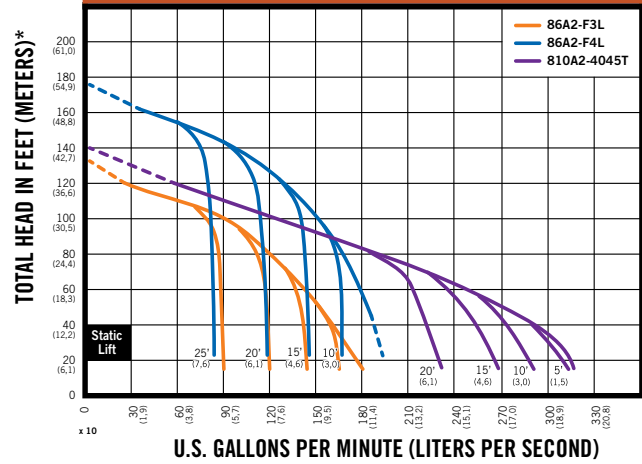

MODEL: 86A2-F4L

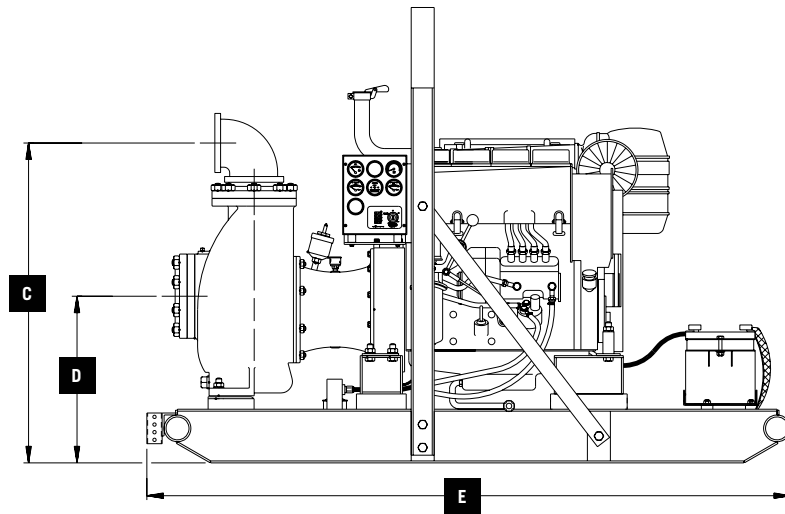

INCHES (MILLIMETERS)		PUMP DIMENSIONAL DATA					
Model	A	B	C	D	E	Suction*	Discharge*
84A2-4024H	75.02 (1905,50)	51.75 (1314,40)	42.76 (1086,10)	25.50 (647,70)	88.01 (2235,50)	4.00	4.00
84A2-F3L	59.44 (1509,80)	38.57 (979,70)	38.81 (985,80)	21.50 (546,10)	81.00 (2057,40)	4.00	4.00
86A2-4024H	75.02 (1905,00)	51.75 (1314,40)	45.75 (1162,00)	25.75 (654,00)	88.01 (2235,50)	6.00	6.00
86A2-F3L	59.44 (1509,80)	38.57 (979,70)	41.75 (1060,50)	21.75 (552,50)	84.00 (2133,60)	6.00	6.00
86A2-F4L	59.44 (1509,80)	38.57 (979,70)	41.75 (1060,50)	21.75 (552,50)	84.00 (2133,60)	6.00	6.00
810A2-4045T	75.03 (1905,80)	51.75 (1314,4)	53.04 (1347,20)	30.00 (762,00)	103.76 (2635,50)	10.00	10.00

*Standard NPT Pipe Threads

