



VARIOUS PATENTS APPLY

Priming Assisted Centrifugal Pump w/Autostart

Model PA12A60D-B-C4.4TA FT4 /S1

Size 12" x 12"



Total Head		Capacity of Pump in U.S. Gallons per Minute (GPM) at Continuous Performance				
P.S.I.	Feet					
45.1	104	1100	1100	1100	1100	1100
43.4	100	2000	2300	2300	2300	2300
39.0	90	2705	3640	3750	3750	3750
34.7	80	3005	4110	4650	4700	4700
30.4	70	3090	4250	5050	5450	5430
26.0	60	3140	4300	5100	5740	5920
22.7	50	3200	4350	5150	5850	6030
17.3	40	3290	4400	5200	5900	6100
13.0	30	3340	4440	5250	5910	6190
Suction Lift		25'	20'	15'	10'	5'

PHOTO NOT AVAILABLE AT TIME OF PUBLISHING

PUMP SPECIFICATIONS**Size:** 4" x 4" (102 mm x 102 mm) Flanged.**Casing:** Gray Iron 30.

Maximum Operating Pressure 71 psi (490 kPa).*

Semi-Open Type, Two Vane Impeller: Ductile Iron 65-45-12.

Handles 3" (76,2 mm) Diameter Spherical Solids.

Impeller Shaft: Stainless Steel 17-4 PH.**Replaceable Wear Plate:** Carbon Steel 1015.**Bearing Housing:** Gray Iron 30.**Seal Plate:** Gray Iron 30.**Seal:** Mechanical, Oil-Lubricated, Double Floating, Self-Aligning. Silicon Carbide Rotating and Stationary Faces. Stainless Steel 316 Stationary Seat. Buna-N and Fluorocarbon Elastomers (DuPont Viton® or Equivalent). Stainless Steel 18-8 Cage and Spring.
Maximum Temperature of Liquid Pumped 160°F (71°C).***Shaft Sleeve:** Stainless Steel 304.**Priming Chamber:** Gray Iron 30 Housing w/Stainless Steel Float and Linkage.**Discharge Check Valve:** Ductile Iron Housing w/Welded Nickel Seat and Buna-N Flapper.**Radial Bearing:** Single Row Roller.**Thrust Bearing:** Single Row Ball.**Bearing and Seal Cavity Lubrication:** SAE 30 Non-Detergent Oil.**Gaskets:** Vegetable Fiber and Buna-N.**O-Rings:** Buna-N and Neoprene.**Hardware:** Standard Plated Steel.**Bearing and Seal Cavity Oil Level Sight Gauges.****Consult Factory for Applications Exceeding Maximum Pressure and/or Temperature Indicated.***Standard Equipment:** Battery. Gear-Driven Air Compressor. Hoisting Bail. Combination Skid Base w/Fuel Tank. Heated Priming Chamber. **Full Feature Control Panel Single Ball Type Float Switch.******Optional Equipment:** **Tandem Axle Over-the-Road Trailer** Transducer Liquid Level Sensor. Skid Base Kit.***50 Ft. (15 m) Standard Length; Dual Switches and Alternate Cable Lengths Available From the Factory.***ENGINE SPECIFICATIONS****Model:** Caterpillar C4.4TA.**EPA Tier** Tier 4.**Type:** Four Cylinder Turbocharged, Diesel Engine.**Displacement** 269 Cu. In. (4,4 Liters).**Governor:** Electronic.**Lubrication:** Forced Circulation.**Air Cleaner:** Dry Type.**Fuel Tank:** 206 U.S. Gals. (780 liters).**Full Load Operating Time:** 32 Hrs.**Starter:** 12V Electric.**Standard Features:** Muffler w/Guard and Weather Cap, DOC/SCR Exhaust After-Treatment System.**Engine Control Features:** Padlockable Box with Throttle Control, Tachometer, Coolant Temperature, Oil Pressure, Voltage and Overstart Indicators/Shutdowns. Manual/Stop/Auto Keyswitch. Audible Startup Warning Delay. Fuel Level Display/Alarm/Shutdown.**CATERPILLAR PUBLISHED PERFORMANCE:**

Maximum Gross BHP (Intermittent)

148 (110 kW) @ 2200 RPM



GORMAN-RUPP PUMPS

www.grpumps.com

Specifications Subject to Change Without Notice

Printed in U.S.A.

Specification Data

APPROXIMATE DIMENSIONS and WEIGHTS

NET WEIGHT: 6650 LBS. (3016,4 K.G.)
SHIPPING WEIGHT: 6950 LBS. (3152,5 KG.)
SHIPPING DIMENSIONS: 732 CU. FT. (20,7 CU. M.)

SECTION CAT, PAGE 101

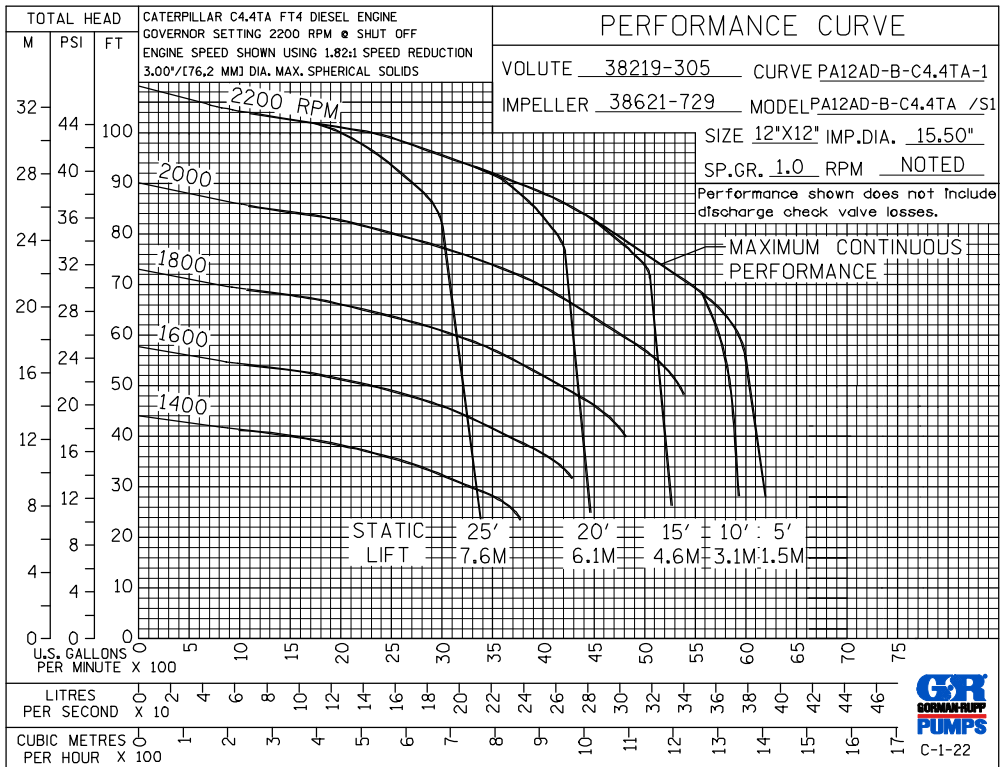
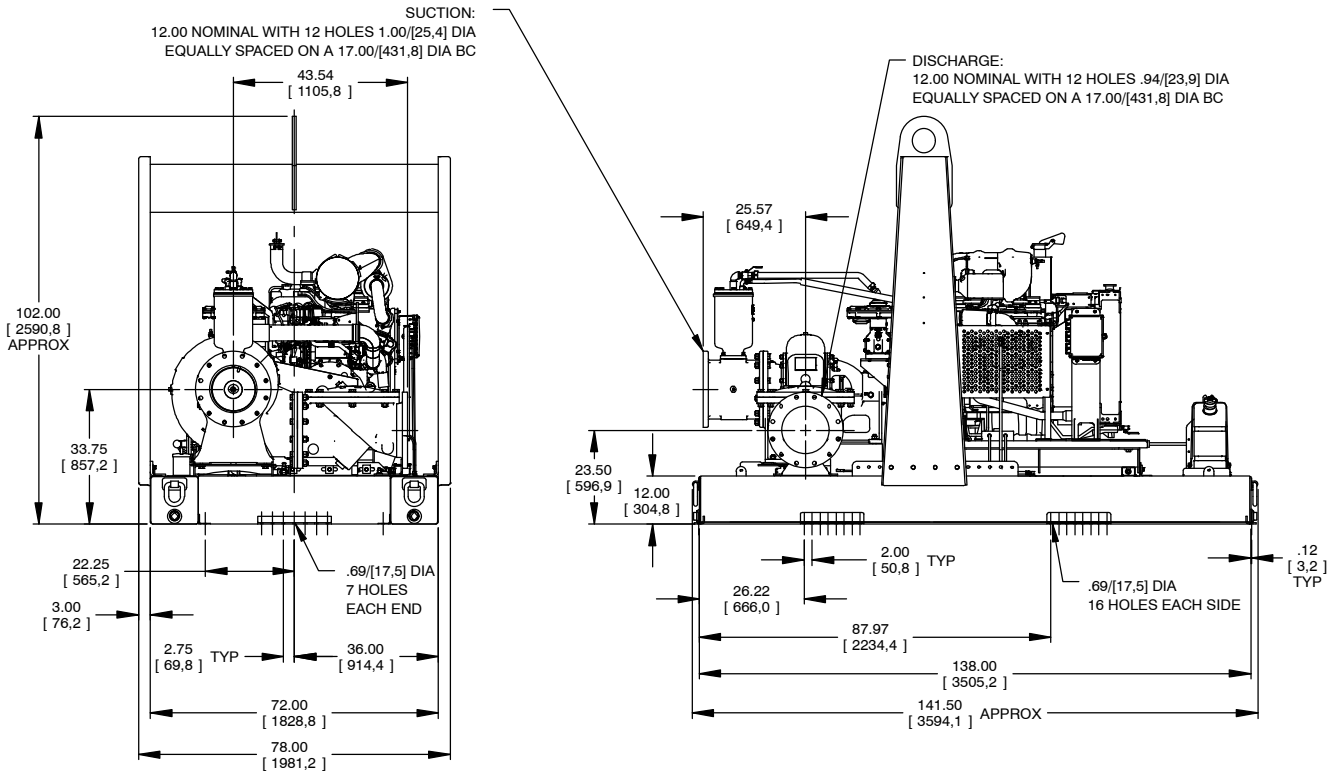

GORMAN-RUPP PUMPS

www.grpumps.com

Specifications Subject to Change Without Notice

Printed in U.S.A.