

Priming Assisted Centrifugal Pump
w/Autostart



VARIOUS PATENTS APPLY

Model PA12A60-B-C4.4TA FT4 /S1

Size 12" x 12"



Total Head		Capacity of Pump in U.S. Gallons per Minute (GPM) at Continuous Performance				
P.S.I.	Feet					
45.1	104	1100	1100	1100	1100	1100
43.4	100	2000	2300	2300	2300	2300
39.0	90	2700	3620	3750	3750	3750
34.7	80	3000	4110	4650	4700	4700
30.4	70	3090	4250	5050	5450	5430
26.0	60	3140	4300	5100	5740	5920
22.7	50	3200	4350	5150	5850	6030
17.3	40	3290	4400	5200	5900	6100
13.0	30	3340	4440	5250	5910	6190
Suction Lift		25'	20'	15'	10'	5'



PUMP SPECIFICATIONS

- Size:** 12 x 12" (305 mm x 305 mm) Flanged.
- Casing:** Gray Iron 30.
- Maximum Operating Pressure** 71 psi (490 kPa).*
- Enclosed Type, Two Vane Impeller:** Ductile Iron 80-56-06. Handles 3" (76,2 mm) Diameter Spherical Solids.
- Suction Spool:** Gray Iron 30.
- Impeller Shaft:** Chrome-Plated Steel.
- Wear Ring:** Ductile Iron 65-45-12.
- Pedestal:** Gray Iron 30.
- Seal Plate:** Gray Iron 30.
- Seal:** Mechanical, SAE 30 Non-Detergent Oil-Lubricated. Silicon Carbide Rotating Face, Silicon Carbide Stationary Seat. Fluorocarbon Elastomers (DuPont Viton® or Equivalent). Stainless Steel 18-8 Cage and Spring. Maximum Temperature of Liquid Pumped, 160°F (71°C).*
- Shaft Sleeve:** Stainless Steel 303/304.
- Priming Chamber:** Gray Iron 30 Housing w/Stainless Steel Float and Linkage.
- Discharge Check Valve:** Ductile Iron Housing w/Welded Nickel Seat and Buna-N Flapper.
- Radial Bearing:** Open Single Row Ball.
- Thrust Bearing:** Open Double Row Ball.
- Bearing Cavity Lubrication** Lithium EP2 Grease.
- Gaskets:** Red Rubber, Buna-N, and Compressed Synthetic Fibers.
- O-Rings:** Buna-N.
- Hardware:** Standard Plated Steel.
- Seal Cavity Oil Level Sight Gauges.**
- *Consult Factory for Applications Exceeding Maximum Pressure and/or Temperature Indicated.*
- Standard Equipment:** Battery. Gear-Driven Air Compressor. Heated Priming Chamber Kit. Hoisting Bail. Combination Skid Base w/Fuel Tank. Full Feature Control Panel. Single Ball Type Float Switch.**
- Optional Equipment:** NPT Suction and Discharge Flange Kits. Liquid Level Transducer.
- **50 Ft. (15 m) Standard Length; Dual Switches and Alternate Cable Lengths Available From the Factory.*

WARNING!
Do not use in explosive atmosphere or for pumping volatile flammable liquids.

ENGINE SPECIFICATIONS

- Model:** Caterpillar C4.4TA.
- EPA Tier:** Tier 4.
- Type:** Four Cylinder, Turbocharged Diesel Engine.
- Displacement:** 269 Cu. In. (4,41 Liters).
- Lubrication:** Forced Circulation.
- Air Cleaner:** Dry Type.
- Fuel Tank:** 206 U.S. Gals. (780 Liters).
- Full Load Operating Time:** 32.0 Hrs.
- Starter:** 12V Electric.
- Standard Features:** Muffler w/Weather Cap. DOC/SCR Exhaust After Treatment System
- Engine Control Features:** Padlockable Box with Throttle Control, Tachometer, Coolant Temperature, Oil Pressure, Voltage and Overstart Indicators/Shutdowns. Manual/Stop/Auto Keyswitch. Audible Startup Warning Delay. Electronic Fuel Level Sensor. Fuel Level Display/Alarm/Shutdown.

CATERPILLAR PUBLISHED PERFORMANCE:

Maximum Gross BHP (Intermittent)
148 (110 kW) @ 2200 RPM



GORMAN-RUPP PUMPS

www.grpumps.com

Specifications Subject to Change Without Notice

Printed in U.S.A.

Specification Data

SECTION CAT, PAGE 98

APPROXIMATE
DIMENSIONS and WEIGHTS

NET WEIGHT:
SHIPPING WEIGHT:
EXPORT CRATE SIZE:

SKID BASE

6990 LBS. (3170,6 KG.)
6990 LBS. (3170,6 KG.)
732 CU. FT. (20,7 CU. M.)

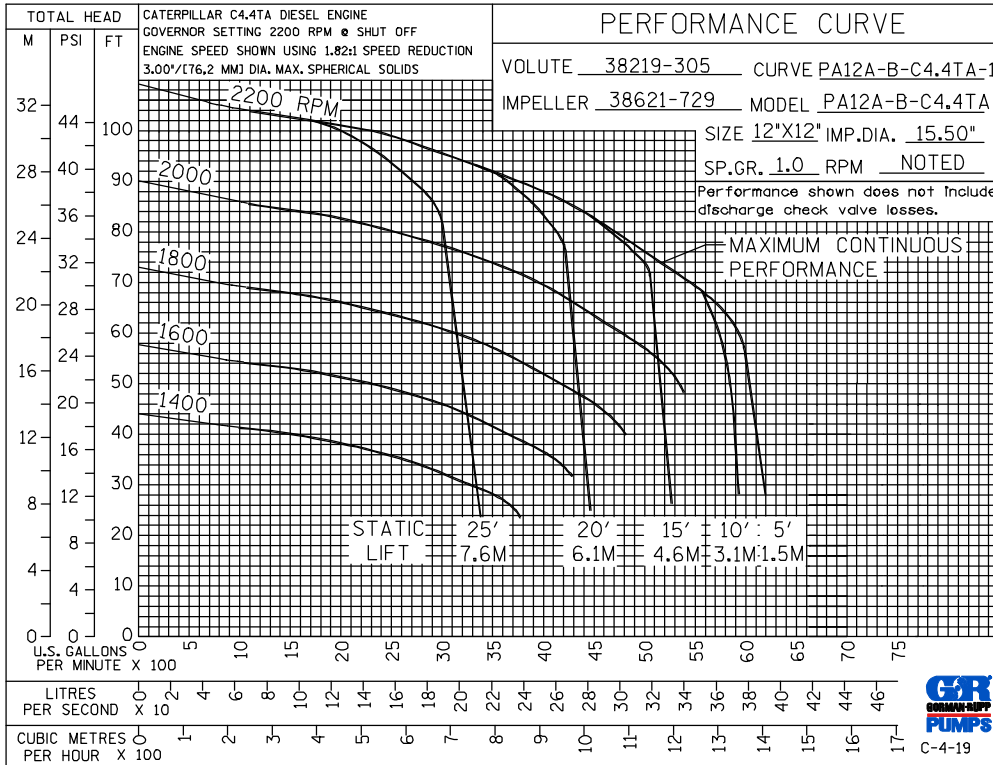
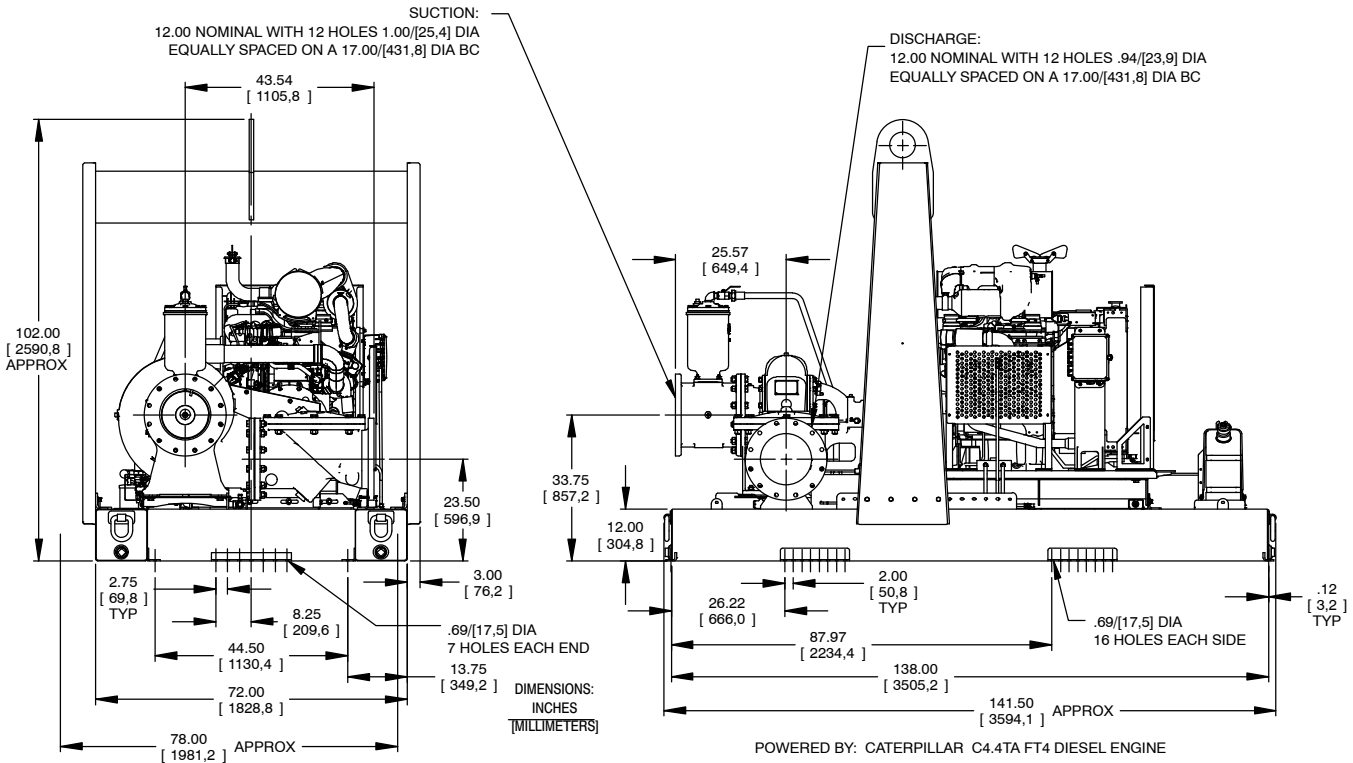

GORMAN-RUPP PUMPS

www.grpumps.com

Specifications Subject to Change Without Notice

Printed in U.S.A.