



VARIOUS PATENTS APPLY

**Diesel Engine Driven/Sound Attenuated
Priming Assisted Centrifugal
Environmental Silent Pump ^{w/}Autostart
Model PA8E60-C4.4TA FT4-ESP /S1
Size 8" x 8"**



Total Head		Capacity of Pump in U.S. Gallons per Minute (GPM) at Continuous Performance			
P.S.I.	Feet				
72.8	168	1200	1200	1200	1200
69.4	160	1440	1440	1440	1440
60.7	140	1960	2040	2040	2040
52.0	120	2000	2560	2640	2640
43.4	100	2040	2610	3020	3200
34.7	80	2070	2640	3060	3580
26.0	60	2100	2670	3100	3660
17.3	40	2120	2700	3140	3710
Suction Lift		20'	15'	10'	5'



PUMP SPECIFICATIONS

Size: 8 x 8" (203 mm x 203 mm) Flanged.
Casing: Ductile Iron 65-45-12.
 Maximum Operating Pressure 109 psi (752 kPa).
Enclosed Type, Two Vane Impeller: Ductile Iron 80-56-06.
 Handles 3" (76,2 mm) Diameter Spherical Solids.
Suction Spool: Gray Iron 30.
Impeller Shaft: Chrome-Plated Steel.
Wear Ring: Ductile Iron 65-45-12.
Pedestal: Gray Iron 30.
Seal Plate: Gray Iron 30.
Seal: Mechanical, Oil-Lubricated. Silicon Carbide Rotating Face. Silicon Carbide Stationary Seat. Fluoro-carbon Elastomers (DuPont Viton[®] or Equivalent). Stainless Steel 18-8 Cage and Spring. Maximum Temperature of Liquid Pumped, 160°F (71°C).
Shaft Sleeve: Stainless Steel 303/304.
Priming Chamber: Gray Iron 30 Housing ^{w/}Stainless Steel Float and Linkage.
Discharge Check Valve: Ductile Iron Housing with Welded Nickel Seat and Buna-N Flapper.
Radial Bearing: Open Single Row Ball.
Thrust Bearing: Open Double Row Ball.
Bearing Lubrication: Lithium EP2 Grease.
Seal Cavity Lubrication: SAE 30 Non-Detergent Oil.
Gaskets: Red Rubber, Buna-N, and Compressed Synthetic Fibers.
O-Rings: Buna-N.
Hardware: Standard Plated Steel.
Seal Cavity Oil Level Sight Gauges.
Standard Equipment: Battery, Gear-Driven Air Compressor. Hoisting Bail. Soundproof (EPA Average (78.5) dBA at 23 feet [7 meters] Under Load) Lightweight Aluminum Enclosure - Removable for Maintenance of Pump or Engine - ^{w/}Lockable Door Panels.Heated Priming Chamber Kit. [Single Ball Type Float Switch.](#), [Full Feature Control Panel](#) .**
Optional Equipment: Skid Drag Base Kit. NPT Suction and Discharge Flange Kits. High Speed (55 MPH/89 KM/H) Single Axle Pneumatic-Tired Wheel Kit ^{w/} DOT-Approved Lights and Electric Brakes. [Tandem Axle Over-the-Road Trailer](#) (Meets DOT Requirements). Submersible Transducer Liquid Level Sensor.
****50 Ft. (15 m) Standard Length; Dual Switches and Alternate Cable Lengths Available From the Factory.**

WARNING!

Do not use in explosive atmosphere or for pumping volatile flammable liquids.

ENGINE SPECIFICATIONS

Model: Caterpillar C4.4TA.
EPA Tier: Tier 4.
Type Turbocharged: Four Cylinder, Diesel Engine
Displacement: 269 Cu. In. (4,41 liters).
Lubrication: Forced Circulation.
Air Cleaner: Dry Type.
Fuel Tank: 110 U.S. Gals. (416 liters).
Full Load Operating Time: 16 Hrs.
Starter: 12V Electric.
Standard Features: Muffler ^{w/}Guard and Weather Cap.
Engine Control Features: Padlockable Box with Throttle Control, Tachometer, Coolant Temperature, Oil Pressure, Voltage and Overstart Indicators/Shutdowns. Manual/Stop/Auto Keyswitch. Audible Startup Warning Delay. Electronic Fuel Level Sensor, Fuel Level Display/Alarm/Shutdown.

CATERPILLAR PUBLISHED PERFORMANCE:
 Maximum Gross BHP (Intermittent)
 131 (97 kW) @ 2200 RPM



GORMAN-RUPP PUMPS

www.grpumps.com

Specifications Subject to Change Without Notice

Printed in U.S.A.

Specification Data

SECTION CAT, PAGE 072

APPROXIMATE
DIMENSIONS and WEIGHTS

NET WEIGHT:
SHIPPING WEIGHT:
EXPORT CRATE SIZE:

SKID BASE

5650 LBS. (2563 KG.)
5900 LBS. (2676,4 KG.)
440 CU. FT. (12,5 CU. M.)

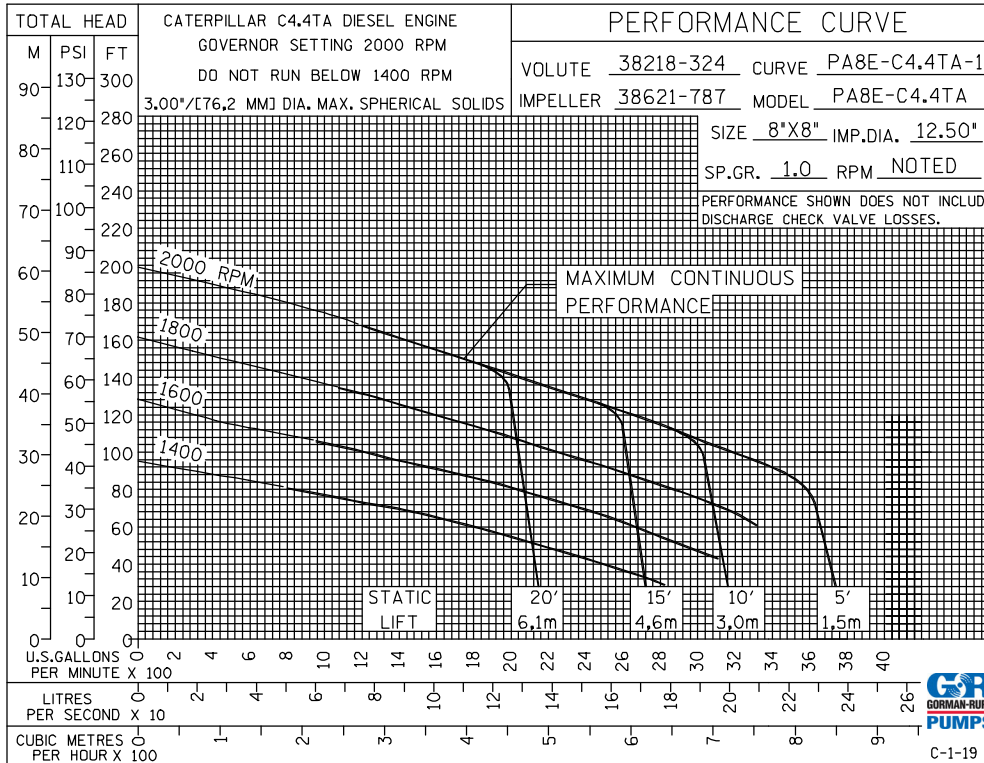
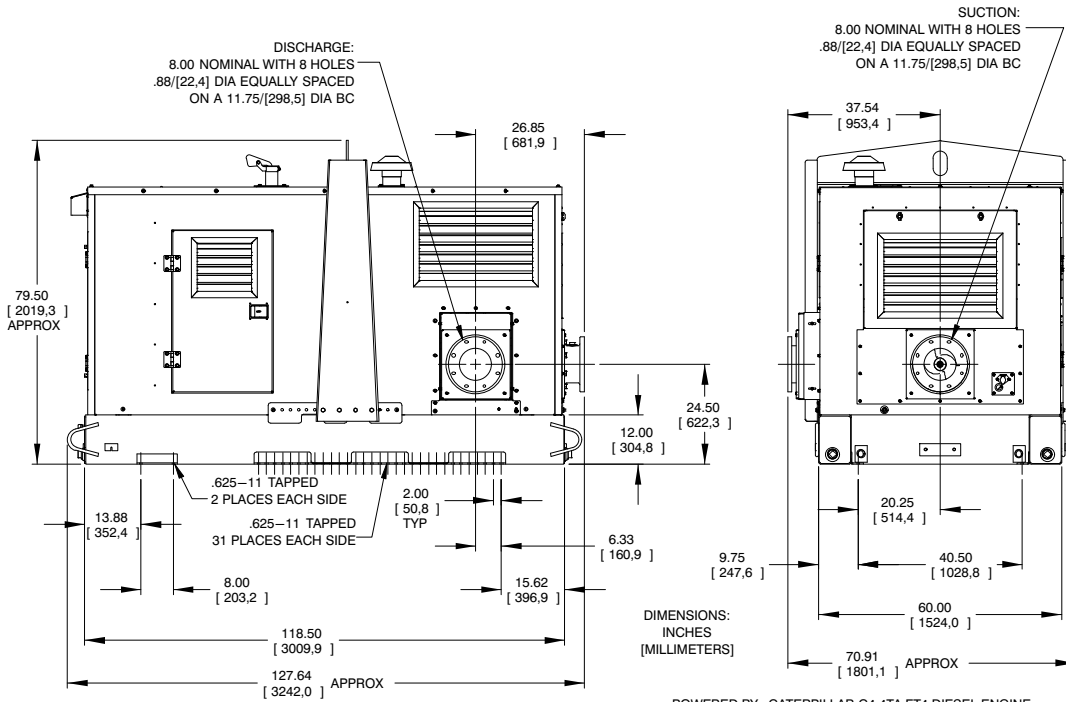

GORMAN-RUPP PUMPS

www.grpumps.com

Specifications Subject to Change Without Notice

Printed in U.S.A.