

**GHS SERIES
 FLEXIBLE SEAL
 HEAVY DUTY STANDARD
 STAINLESS STEEL ROTARY
 GEAR PUMP**

This heavy duty series with internal “wetted” parts of 316 Stainless Steel is ideal for handling corrosive applications. Superior rotor shaft support and an integral maintenance-free radial/thrust bearing, reduce deflection and wear. Due to the “galling” nature of stainless, extra internal clearance is necessary. A capacity correction table for liquids less than 750 SSU is available in Section 500.

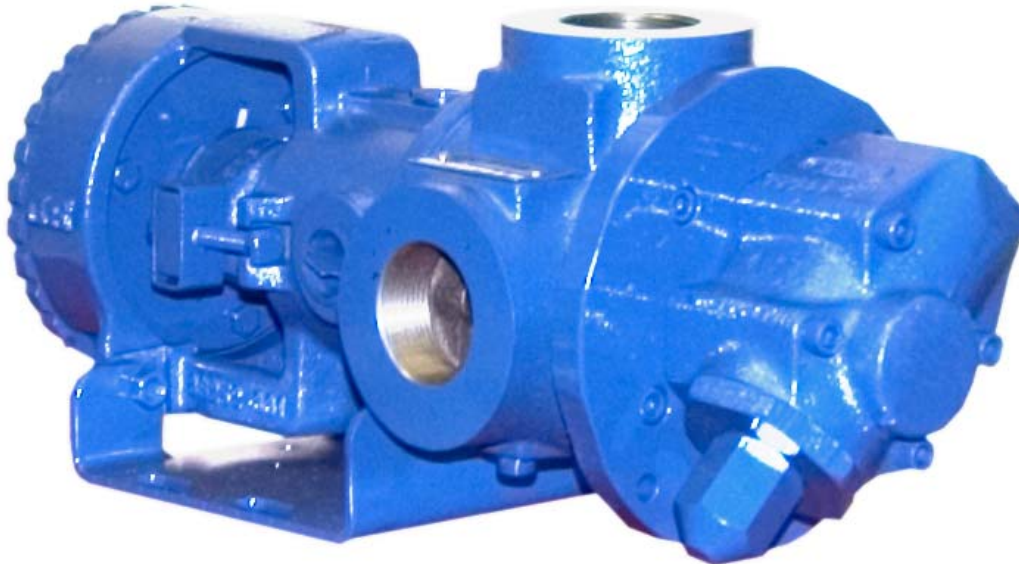

SHOWN ^W/INTERCHANGE FOOT BRACKET

The GHS stainless series is designed for applications in the operating ranges noted below. These units are available with head and backhead jackets for temperature control, silicon carbide bushings for wear resistance, and numerous shaft seal options described on the following pages.

FEATURES

- 200 PSI CAPABILITY
- BALL BEARING THRUST CONTROL
- ROTOR END CLEARANCE EXTERNALLY ADJUSTABLE
- EXCEPTIONAL SEAL VERSATILITY WITH INTERNAL SEAL VENT
- COMPUTER PROFILED GEARING FOR QUIET OPERATION
- MULTIPLE PORT POSITIONS
- FLEXIBLE SEAL DESIGN ALLOWS FOR A VARIETY OF INDUSTRY STANDARD SEALS OR PACKING

OPERATING RANGE

- CAPACITY (GPM): (3 TO 295)
 [LPM] : [11 TO 1116]
- PRESSURE (PSI) : [0 TO 200]
 [BAR] : [0 TO 14]
- VISCOSITY (SSU) : (28 TO 2,000,000)
 [cSt] : [1 TO 440,000]
- TEMPERATURE (F) : (-30° TO 675°)
 [C] : [-34° TO 358°]

APPLICATIONS

- USE WITH ANY CLEAN LIQUID COMPATIBLE WITH 316 STAINLESS STEEL
- ★ BOOSTER SERVICE
 - ★ CIRCULATING
 - ★ FILTERING
 - ★ LUBRICATING
 - ★ TRANSFERRING

EXTERIOR	BACKHD	ROTOR & IDLER	HOUSING PORTS	BUSHING	IDLER PIN	SHAFT	SHAFT SEALING		ROTA-TION	INTERNAL RELIEF VALVE	
							MECH. SEAL	PACKING		MATERIAL	SETTING
316 STAIN. STEEL	CAST IRON	316 STAIN. STEEL	GHC 180° FLG. GHS 90° NPT	CARBON GRAPHITE	COATED 316 SST	STAIN. STEEL	CARBON, SIC, TEFLON ENC.	CARBON FIBER	C.W.	316 STAINLESS STEEL	75 PSI [5 BAR]

G H C 1 DC 9 - B
G H S 1 DC 9 - B
 | | | | | | | | | | | |
 GEAR DUTY DESIGN PORT SIZE HYD. SIZE SEAL STYLE

Standard Models

MODEL NUMBER		NOM. CAPACITY - SPEED				MAXIMUM				SHIPPING DATA	
		MAXIMUM		ALTERNATIVE		DIFF. PRESSURE - PSI [BAR]			TEMP.	Wt.	Vol.
		GPM [LPM]	RPM 60 Hz [50 HZ]	GPM [LPM]	RPM 60 Hz [50 HZ]	BELOW 38 SSU [4 cSt]	38 TO 100 SSU [21 cSt]	100 TO 250,000 SSU [55,000 cSt]	°F [°C]		
GHC 1 DC9-B ① ● ▸	GHS 1 DC9-B ① ● ● GHS 1 DC10-B ① ● ■	9 [28]		6 [19]						32 [14,5]	2.9
GHC 1 DE9-B ① ● ● ▸	GHS 1 DE9-B ① ● ● ● GHS 1 DE10-B ① ● ● ■	11 [35]		7 [22]						32 [14,5]	2.9
GHC 1-1/2 GC9-B ● ● ▸	GHS 1-1/2 GC9-B ● ● ● GHS 1-1/2 GC10-B ● ● ■	16 [50]		10 [32]						63 [28,6]	2.9
	GHS 2 GC9-B ● ● ● GHS 2 GC10-B ● ● ■									63 [28,6]	2.9
GHC 1-1/2 GF9-B ● ● ▸	GHS 1-1/2 GF9-B ● ● ● ● GHS 1-1/2 GF10-B ● ● ● ■	23 [73]	1750 [1460]	15 [47]	1150 [960]					GHC ● 63 [28,6] 2.9 350 [177] 63 [28,6] 2.9	
	GHS 2 GF9-B ● ● ● ● GHS 2 GF10-B ● ● ● ■									GHS ● 63 [28,6] 2.9 400 [204] 63 [28,6] 2.9	
GHC 1-1/2 GH9-B ● ● ▸	GHS 1-1/2 GH9-B ● ● ● ● GHS 1-1/2 GH10-B ● ● ● ■	31 [98]		20 [63]		75 [5]	100 [7]	200 [14]		63 [28,6] 2.9 63 [28,6] 2.9	
	GHS 2 GH9-B ● ● ● ● GHS 2 GH10-B ● ● ● ■									63 [28,6] 2.9	
GHC 1-1/2 GJ9-B ● ● ▸	GHS 1-1/2 GJ9-B ● ● ● ● GHS 1-1/2 GJ10-B ● ● ● ■	38 [120]		25 [79]						63 [28,6] 2.9	
	GHS 2 GJ9-B ● ● ● ● GHS 2 GJ10-B ● ● ● ■									63 [28,6] 2.9	
	GHS 2 JG9-B ● ● ● ● GHS 2 JG10-B ● ● ● ■	40 [126]	1150 [960]	30 [95]	870 [725]					161 [73,2] 5.3	
GHC 3 JG9-B ● ● ▸	GHS 3 JG9-B ● ● ● ● GHS 3 JG10-B ● ● ● ■									161 [73,2] 5.3	
	GHS 2 JJ9-B ● ● ● ● GHS 2 JJ10-B ● ● ● ■	56 [177]		42 [133]						161 [73,2] 5.3	
GHC 3 JJ9-B ● ● ▸	GHS 3 JJ9-B ● ● ● ● GHS 3 JJ10-B ● ● ● ■									161 [73,2] 5.3	

STANDARD MODELS CONTINUED

① 3450 [2875] RPM PERMISSIBLE TO 1,000 SSU [220 cSt.] AND 100 PSI [7 BAR]

● MECHANICAL SEAL
■ PACKING/LIP SEAL

▸ PORTS ARE COMPATIBLE WITH 150# ANSI FLANGES. ALL OTHER PORTS ARE TAPPED NPT FOR ANSI PIPE. OPTIONAL [DIN] FLANGES OR TAPPED [BSP] PORTS ARE AVAILABLE FOR EXPORT MARKET.

NOTE: RECOMMENDED PORT SIZES ARE SHOWN IN **BOLDFACE**. EXAMPLE: **GHC 1 DC9-B, GHS 1 DC9-B**

THE GORMAN-RUPP COMPANY • MANSFIELD, OHIO

GORMAN-RUPP OF CANADA LIMITED • ST. THOMAS, ONTARIO, CANADA

Standard Models (Continued)

MODEL NUMBER		NOM. CAPACITY - SPEED				MAXIMUM				SHIPPING DATA	
		MAXIMUM		ALTERNATIVE		DIFF. PRESSURE - PSI [BAR]			TEMP.	Wt.	Vol.
		GPM [LPM]	RPM 60 Hz [50 HZ]	GPM [LPM]	RPM 60 Hz [50 HZ]	BELOW 38 SSU [4 cSt]	38 TO 100 SSU [21 cSt]	100 TO 250,000 SSU [55,000 cSt]	°F [°C]	LBS [KG]	CU. FT.
GHC	GHS 2 JL9-B ●	77 [243]	1150 [960]	58 [133]	870 [725]	75 [5]	100 [7]	200 [14]	GHC ●	161 [73,2]	5.3
	GHS 2 JL10-B ■									161 [73,2]	
GHC 3 JL9-B ● †	GHS 3 JL9-B ●	107 [338]	960 [960]	81 [256]	580 [480]	75 [5]	100 [7]	200 [14]	GHC ●	161 [73,2]	5.3
	GHS 3 JL10-B ■									161 [73,2]	
GHC 3 JP9-B ● †	GHS 2 JP9-B ●	99 [375]	960 [960]	80 [252]	580 [480]	75 [5]	100 [7]	200 [14]	GHC ●	161 [73,2]	5.3
	GHS 2 JP10-B ■									161 [73,2]	
GHC 3 JP9-B ● †	GHS 3 JP9-B ●	132 [500]	960 [960]	80 [252]	580 [480]	75 [5]	100 [7]	200 [14]	GHC ●	161 [73,2]	5.3
	GHS 3 JP10-B ■									161 [73,2]	
GHC 3 NK9-B ● †	GHS 2 NK9-B ●	165 [624]	960 [960]	99 [312]	580 [480]	75 [5]	100 [7]	200 [14]	GHC ●	180 [81,8]	5.3
	GHS 2 NK10-B ■									180 [81,8]	
GHC 3 NK9-B ● †	GHS 2-1/2 NK9-B ●	172 [542]	960 [960]	115 [362]	580 [480]	75 [5]	100 [7]	200 [14]	GHC ●	180 [81,8]	5.3
	GHS 2-1/2 NK10-B ■									180 [81,8]	
GHC 3 NK9-B ● †	GHS 3 NK9-B ●	215 [678]	720 [600]	143 [451]	480 [400]	75 [5]	100 [7]	200 [14]	GHC ●	180 [81,8]	5.3
	GHS 3 NK10-B ■									180 [81,8]	
GHC 3 NM9-B ● †	GHS 2 NM9-B ●	172 [542]	720 [600]	143 [451]	480 [400]	75 [5]	100 [7]	200 [14]	GHC ●	180 [81,8]	5.3
	GHS 2 NM10-B ■									180 [81,8]	
GHC 3 NM9-B ● †	GHS 2-1/2 NM9-B ●	172 [542]	720 [600]	143 [451]	480 [400]	75 [5]	100 [7]	200 [14]	GHC ●	180 [81,8]	5.3
	GHS 2-1/2 NM10-B ■									180 [81,8]	
GHC 3 NP9-B ● †	GHS 3 NP9-B ●	172 [542]	720 [600]	143 [451]	480 [400]	75 [5]	100 [7]	200 [14]	GHC ●	180 [81,8]	5.3
	GHS 3 NP10-B ■									180 [81,8]	
GHC 3 NP9-B ● †	GHS 2-1/2 NP9-B ●	172 [542]	720 [600]	143 [451]	480 [400]	75 [5]	100 [7]	200 [14]	GHC ●	180 [81,8]	5.3
	GHS 2-1/2 NP10-B ■									180 [81,8]	
GHC 3 NP9-B ● †	GHS 2 RM9-B ●	172 [542]	720 [600]	143 [451]	480 [400]	75 [5]	100 [7]	200 [14]	GHC ●	357 [162]	10.7
	GHS 2 RM10-B ■									357 [162]	
GHC 3 RM9-B ● †	GHS 2-1/2 RM9-B ● †	172 [542]	720 [600]	143 [451]	480 [400]	75 [5]	100 [7]	200 [14]	GHC ●	357 [162]	10.7
	GHS 2-1/2 RM10-B ■ †									357 [162]	
GHC 3 RM9-B ● †	GHS 3 RM9-B ● †	172 [542]	720 [600]	143 [451]	480 [400]	75 [5]	100 [7]	200 [14]	GHC ●	357 [162]	10.7
	GHS 3 RM10-B ■ †									357 [162]	
GHC 3 RM9-B ● †	GHS 4 RM9-B ● †	172 [542]	720 [600]	143 [451]	480 [400]	75 [5]	100 [7]	200 [14]	GHC ●	357 [162]	10.7
	GHS 4 RM10-B ■ †									357 [162]	
GHC 3 RP9-B ● †	GHS 3 RP9-B ● †	172 [542]	720 [600]	143 [451]	480 [400]	75 [5]	100 [7]	200 [14]	GHC ●	357 [162]	10.7
	GHS 3 RP10-B ■ †									357 [162]	
GHC 3 RP9-B ● †	GHS 4 RP9-B ● †	172 [542]	720 [600]	143 [451]	480 [400]	75 [5]	100 [7]	200 [14]	GHC ●	357 [162]	10.7
	GHS 4 RP10-B ■ †									357 [162]	

STANDARD MODELS CONTINUED

- MECHANICAL SEAL
- PACKING/LIP SEAL

† PORTS ARE COMPATIBLE WITH 150# ANSI FLANGES. ALL OTHER PORTS ARE TAPPED NPT FOR ANSI PIPE. OPTIONAL [DIN] FLANGES OR TAPPED [BSP] PORTS ARE AVAILABLE FOR EXPORT MARKET.

NOTE: RECOMMENDED PORT SIZES ARE SHOWN IN **BOLDFACE**. EXAMPLE: **GHC 1 DC9-B, GHS 1 DC9-B**

THE GORMAN-RUPP COMPANY • MANSFIELD, OHIO
 GORMAN-RUPP OF CANADA LIMITED • ST. THOMAS, ONTARIO, CANADA

MODEL NUMBER		NOM. CAPACITY - SPEED				MAXIMUM				SHIPPING DATA	
		MAXIMUM		ALTERNATIVE		DIFF. PRESSURE - PSI [BAR]			TEMP.	Wt.	Vol.
		GPM [LPM]	RPM 60 Hz [50 HZ]	GPM [LPM]	RPM 60 Hz [50 HZ]	BELOW 38 SSU [4 cSt]	38 TO 100 SSU [21 cSt]	100 TO 250,000 SSU [55,000 cSt]	°F [°C]	LBS [KG]	CU. FT.
GHC	GHS										
	GHS 3 RR9-B ● ▸ GHS 3 RR10-B ■ ▸	255 [804]	720 [600]	170 [536]	480 [400]	75 [5]	100 [7]	200 [14]	GHS ● 400 [204] ■ 500 [260]	357 [162]	10.7
	GHS 4 RR9-B ● ▸ GHS 4 RR10-B ■ ▸			196 [618]						357 [162]	
	GHS 4 RS9-B ● ▸ GHS 4 RS10-B ■ ▸			295 [930]						357 [162]	

▸ PORTS ARE COMPATIBLE WITH 150# ANSI STAINLESS STEEL FLANGES. ALL OTHER PORTS ARE TAPPED NPT FOR ANSI PIPE. OPTIONAL [DIN] FLANGES OR TAPPED [BSP] PORTS AVAILABLE FOR EXPORT MARKET.

NOTE: RECOMMENDED PORT SIZES ARE SHOWN IN BOLDFACE. EXAMPLE: **GHC 1 DC9-B, GHS 1 DC9-B**

APPLICATION RECOMMENDATIONS:		
APPLICATION	OPTIONS REQUIRED (Select One From Each Row)	OPERATING LIMITATIONS
GHS ONLY HIGH TEMPERATURE	25U, 25V, OR 25W 35J – 35M (AS REQ'D) 40R, 70K 61H OR 65Q	TEMPERATURE: 675 °F MAX. PRESSURE: 200 PSI MAX.
GHS ONLY JACKETED	40K, 40W, 41U, 41W	LIMIT JACKET PRESSURE TO 150 PSI

NOTE: PROPER PUMP APPLICATION REQUIRES CONSIDERATION OF ADDITIONAL FACTORS. PLEASE REVIEW APPLICATION GUIDE IN SECTION 500 OR CONSULT THE FACTORY.

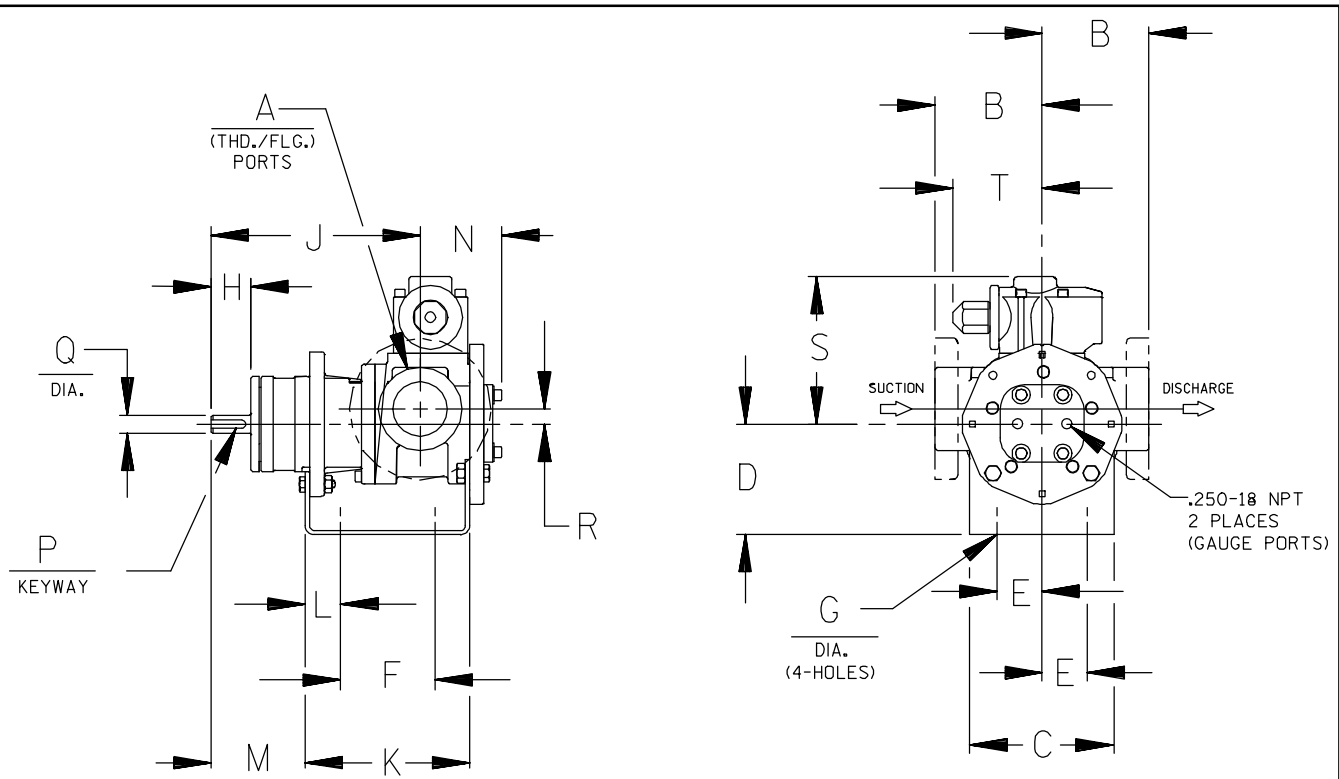

CAD FILE NO.: 16458B

MODEL NUMBERS	PUMP DIMENSIONS - INCHES [MILLIMETERS]																	
	A	B	C	D	E	F	G	H	J	K	L	M	N	P	Q	R	S	T
GHC D	1"	2.50 [64] †	4.00 [102]	3.50* [89]	1.62 [41]	3.12 [79]	.41 [10]	1.16 [30]	6.19 [157]	5.04 [128]	.76 [19]	2.62 [66]	2.74 [70]	.12 [3]	.50 [13]	.62 [16]	5.19 [132]	3.58 [91]
		4.00* [102] †		5.25 [133]										.75 [19]				
GHC G	1-1/2"	3.50 [89] †	5.88 [149]	3.50* [89]	1.62 [41]	4.00 [102]	.41 [10]	1.62 [41]	8.50 [216]	6.71 [170]	1.06 [27]	3.82 [97]	3.35 [85]	.19 [5]	.75 [19]	.62 [16]	6.00 [152]	3.62 [92]
		4.00* [102] †		4.50 [114]										5.25 [133]				
GHC J	3"	4.50 [114] †	6.88 [175]	4.50 [114]	2.88 [73]	4.25 [108]	.44 [11]	2.50 [64]	12.12 [308]	9.75 [248]	1.75 [44]	5.50 [140]	4.66 [118]	.25 [6]	1.00 [25]	1.12 [28]	9.06 [230]	6.75 [171]
		6.00* [152] †		5.25* [133]										6.25 [159]				

* STANDARD DIMENSION

† PORTS ARE COMPATIBLE WITH 125* OR 250* ANSI CAST IRON FLANGES. ALL OTHER PORTS ARE TAPPED NPT FOR ANSI PIPE. OPTIONAL (DIN) FLANGES OR TAPPED (BSP) PORTS AVAILABLE FOR EXPORT MARKET.

† 90° HOUSING

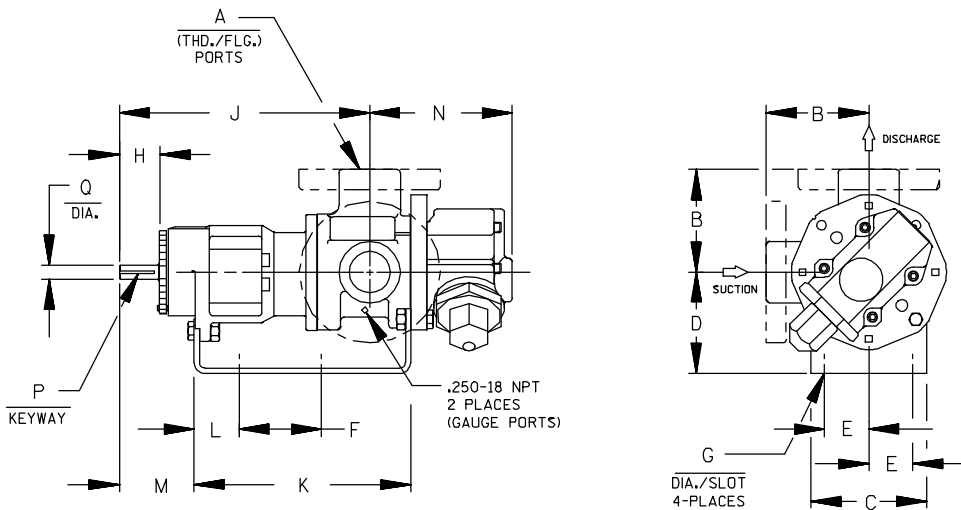

CAD FILE NO.: 16669G

MODEL NUMBERS	PUMP DIMENSIONS - INCHES [MILLIMETERS]														
	A	B	C	D	E	F	G	H	J	K	L	M	N	P	Q
GHS D	1"	2.50* [641]	4.00 [102]	3.50* [891]	1.62 [41]	5.50 [140]	.41 [10]	1.16 [30]	8.43 [214]	7.54 [192]	1.09 [28]	2.29 [58]	4.98 [127]	.12 [3] x .75 [19]	.50 [13]
		4.00 † [102]		5.25 [133]											
GHS G	1-1/2" 2"	3.50* [891]	4.88 [124]	3.50* [891]	1.62 [41]	8.00 [203]	.41 [10]	1.62 [41]	12.06 [306]	10.72 [272]	1.52 [39]	3.35 [85]	5.70 [145]	.19 [5] x 1.25 [32]	.75 [19]
		4.00 † [102]		5.25 [133]											
GHS J	2" 3"	4.50* [114]	6.88 [175]	5.25* [133]	2.88 [73]	10.00 [254]	.44 [11]	2.50 [64]	15.68 [398]	14.31 [363]	2.77 [70]	4.48 [114]	8.50 [216]	.25 [6] x 2.00 [51]	1.00 [25]
		6.00 † [152]		6.25 [159]											
GHS N	2" 3"	5.12 [130]	8.00 [203]	4.50 [114]	2.88 [73]	10.00 [254]	.44 [11]	2.58 [66]	16.37 [416]	15.14 [385]	2.69 [68]	4.56 [116]	8.72 [221]	.25 [6] x 2.00 [51]	1.12 [28]
				5.25* [133]											
GHS R	2"	6.50 [165]	10.50 [267]	7.00 [178]	3.75 [95]	13.75 [349]	.52 [13]	2.25 [57]	17.87 [454]	17.36 [441]	1.86 [47]	4.70 [119]	11.31 [287]	.38 [10] x 1.88 [48]	1.44 [37]
	2-1/2"														
	3"														
	4"	7.19 † [183]													

* STANDARD DIMENSION

† PORTS ARE COMPATIBLE WITH 150# OR 300# ANSISTAINLESS STEEL FLANGES. ALL OTHER PORTS ARE TAPPED NPT FOR ANSI PIPE. OPTIONAL (DIN) FLANGES OR TAPPED (BSP) PORTS AVAILABLE FOR EXPORT MARKET.

‡ 180° HOUSING

GHC/GHS

FOR GHC DRIVE OPTIONS

AND DIMENSIONS

SEE SECTION 540

FOR GHS DRIVE OPTIONS

AND DIMENSIONS

SEE SECTION 545



PERFORMANCE CURVES

SPEED VS. CAPACITY/HORSEPOWER

NM

Hydraulic Size

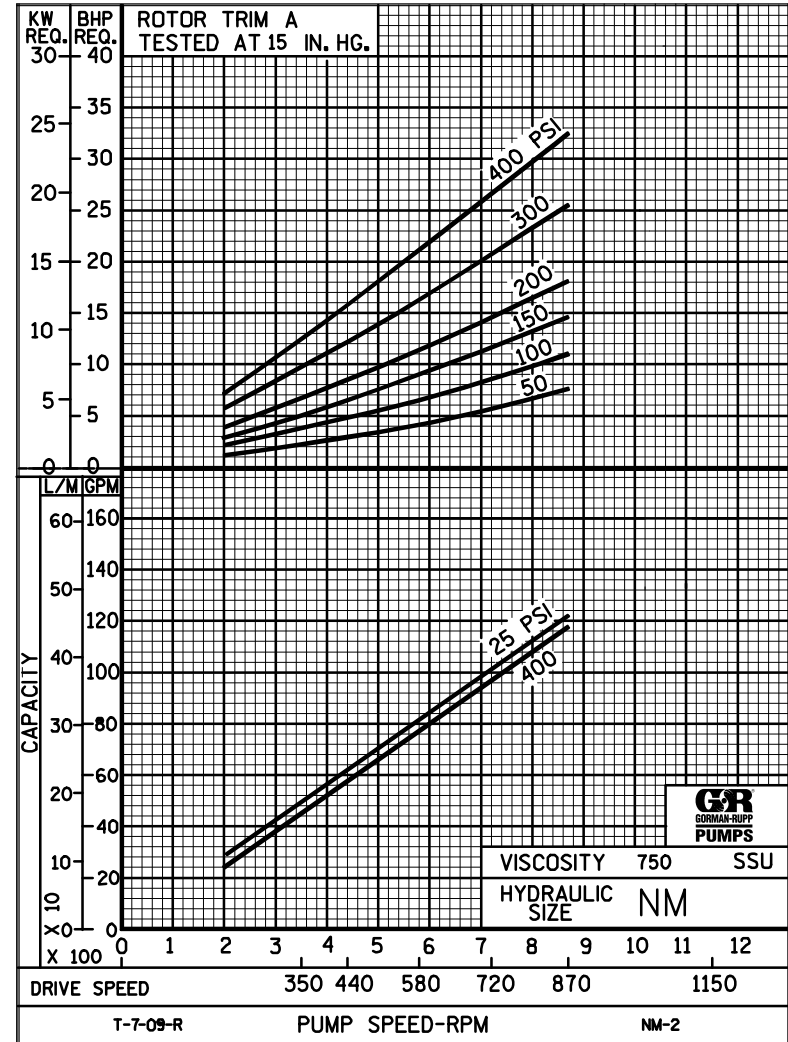
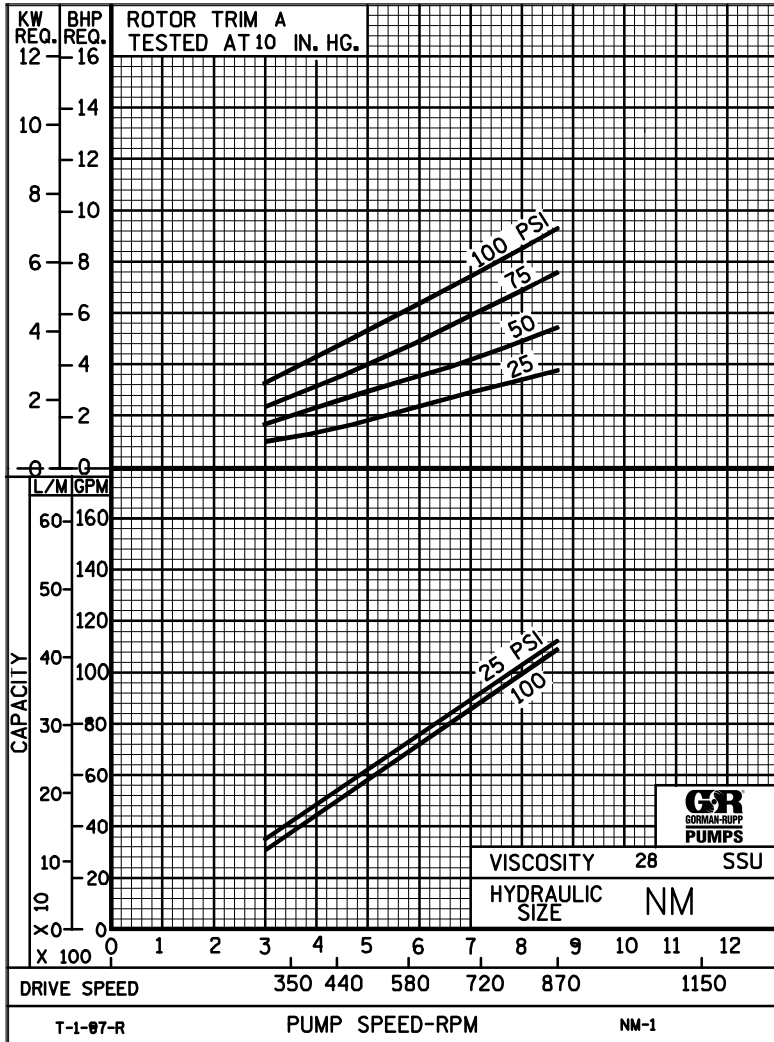

THE GORMAN-RUPP COMPANY • MANSFIELD, OHIO
 GORMAN-RUPP OF CANADA LIMITED • ST. THOMAS, ONTARIO, CANADA



PERFORMANCE CURVES

SPEED VS. CAPACITY/HORSEPOWER

NM

Hydraulic Size

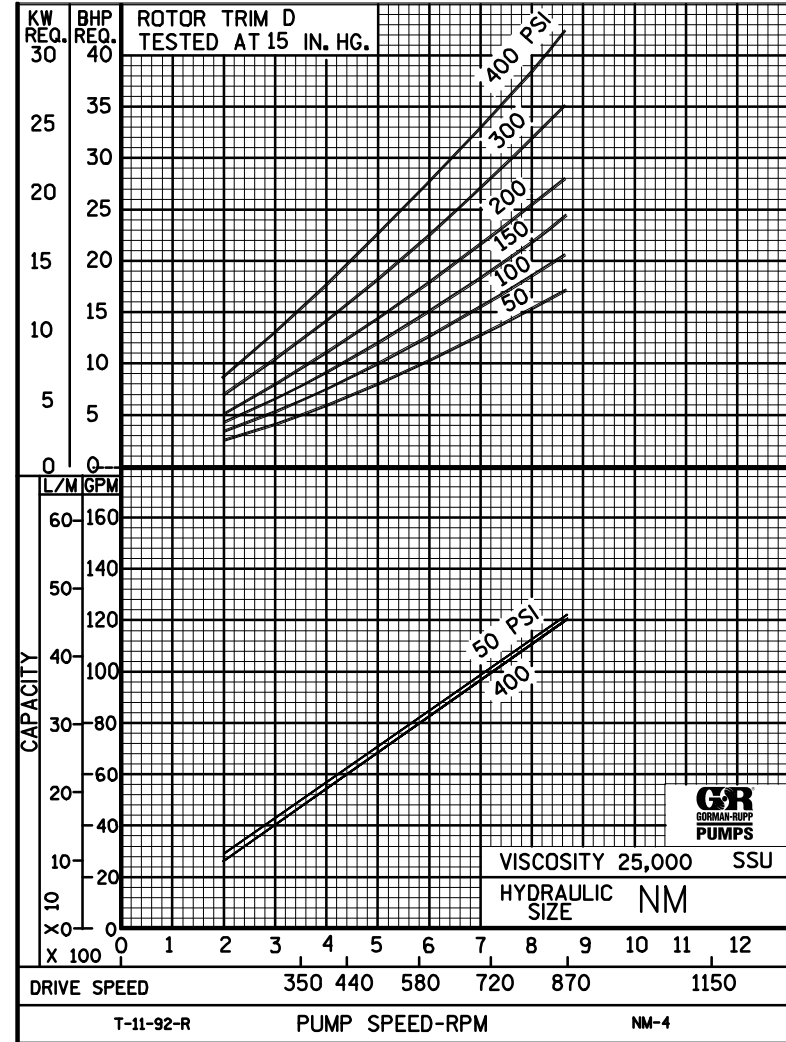
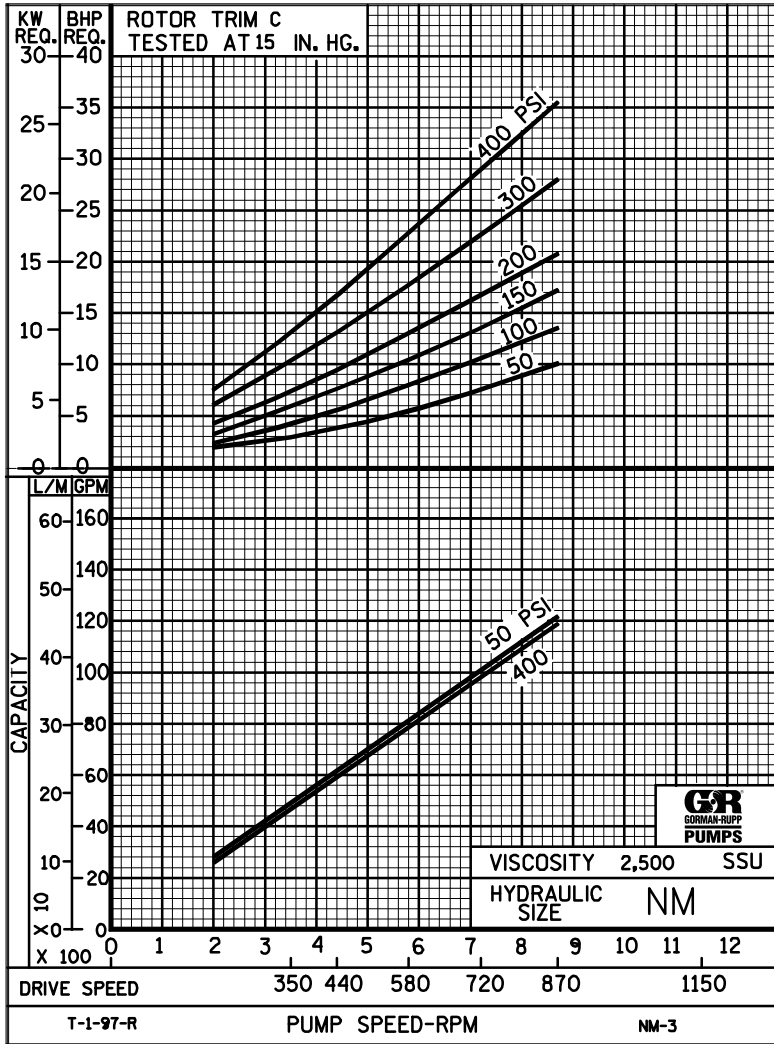

THE GORMAN-RUPP COMPANY • MANSFIELD, OHIO
 GORMAN-RUPP OF CANADA LIMITED • ST. THOMAS, ONTARIO, CANADA



NM

PUMP HYDRAULIC SIZE CHART

SEC. 500

Page 94

January 2010

120 GPM
870 RPM

NOMINAL		ROTOR TRIM	VISCOSITY (SSU)	N.I.P.R. (PSIA)	FRICTION PIPE LOSS (PSI/FT) (Based on Sch 40 Steel Pipe)					FULL BYPASS RELIEF VALVE PRESSURE (PSI)					CAPACITY (GPM) / H.P. REQUIRED													
CAP. GPM	SPEED RPM				PIPE DIAMETER					CRACKING PRESS. (PSI)					DIFFERENTIAL PRESSURE (PSI)													
					2"	2 1/2"	3"	4"	5"	LOW PRES R/V			HI PRES R/V		MEDIUM DUTY AND HEAVY DUTY				HEAVY DUTY ONLY									
120	870	STD	28	3.8	.01	.01	.01	.01	.01	64	92	118			113	111	110	109										
			32		.09	.04	.02	.01	.01						3.9	5.5	7.8	9.5										
			38	3.8	.11	.05	.02	.01	.01	64	92	118	166			116	115	114	113	110								
			50		.13	.06	.02	.01	.01							4.0	5.6	7.9	9.6	13								
			70	3.8	.15	.07	.02	.01	.01	66	94	122	168	220			119	118	117	116	113	112						
			100		.17	.07	.03	.01	.01								4.3	6.0	8.0	9.6	13	17						
			150	3.8	.19	.08	.03	.01	.01	66	94	124	171	222			120	120	119	118	116	116	115	109				
			200		.20	.09	.03	.01	.01								4.8	6.3	8.1	9.8	13	17	24	31				
			300	3.8	.23	.10	.03	.01	.01	68	96	127	173	224			121	121	120	120	118	117	117	112				
			500		.24	.10	.04	.02	.01								5.6	7.1	8.9	10	14	18	25	32				
		750	3.8	.29	.14	.06	.02	.01	70	98	130	175	226			122	122	121	121	119	119	118	115					
		1,000		.39	.19	.08	.03	.01								6.7	8.0	9.8	11	15	19	26	33					
		2,000	4.9	.78	.38	.16	.06	.02	78	106	136	182	232			122	122	122	121	121	121	119	118					
		3,500		1.36	.67	.28	.10	.04								9.1	10	12	14	18	21	28	36					
		5,000	5.6	1.93	.95	.40	.14	.06	82	108	138	185	235			122	122	122	121	121	121	119	118					
		7,500		2.90	1.43	.60	.20	.08								11	12	14	16	20	24	30	38					
		10,000	6.3	3.87	1.90	.80	.27	.11	84	110	140	188	239			122	121	121	121	121	121	120	119					
		15,000		5.80	2.85	1.20	.41	.17								13	15	17	19	22	26	33	40					
		20,000	6.9	7.73	3.80	1.60	.54	.22	84	112	142	192	242			122	121	121	121	121	121	121	120					
		25,000		9.66	4.75	1.99	.67	.27								15	17	19	21	25	28	35	42					
50,000																												
75,000																												
100,000																												
150,000																												
200,000																												
250,000																												

(NOTE) For speeds not shown on the pump hydraulic charts, consult factory.



NM

PUMP HYDRAULIC SIZE CHART

SEC. 500

Page 95

January 2010

**80 GPM
580 RPM**

NOMINAL		ROTOR TRIM	VISCOSITY (SSU)	N.I.P.R. (PSIA)	FRICTION PIPE LOSS (PSI/FT) (Based on Sch 40 Steel Pipe)					FULL BYPASS RELIEF VALVE PRESSURE (PSI)					CAPACITY (GPM) / H.P. REQUIRED											
CAP. GPM	SPEED RPM				PIPE DIAMETER					CRACKING PRESS. (PSI)					DIFFERENTIAL PRESSURE (PSI)											
					2"	2 1/2"	3"	4"	5"	LOW PRES R/V		HI PRES R/V			MEDIUM DUTY AND HEAVY DUTY				HEAVY DUTY ONLY							
							50	75	100	150	200	25	50	75	100	150	200	300	400							
80	580	STD	28	2.1	.01	.01	.01	.01	.01	58	84	114			73	72	71	70								
			32		.04	.02	.01	.01	.01						2.6	3.7	4.6	6.2								
			38	2.1	.05	.02	.01	.01	.01	58	84	114	160			76	75	74	73	71						
			50		.06	.03	.01	.01	.01							2.6	3.8	4.6	6.3	8.7						
			70	2.1	.07	.03	.01	.01	.01	60	86	116	160	206			78	78	77	76	74	73				
			100		.08	.04	.02	.01	.01								2.7	3.8	4.8	6.4	8.8	11				
			150	2.1	.10	.04	.02	.01	.01	60	88	116	164	210			80	79	79	78	76	76	73	72		
			200		.10	.05	.02	.01	.01								2.8	3.9	4.9	6.4	8.9	11	16	21		
			300	2.1	.10	.05	.02	.01	.01	62	90	118	164	214			81	80	80	79	78	78	75	75		
			500		.13	.07	.03	.01	.01								3.1	4.1	5.2	6.5	9.0	12	16	21		
		750	2.1	.20	.10	.04	.02	.01	64	92	118	168	218			81	81	81	81	79	79	77	77			
		1,000		.26	.13	.06	.02	.01								3.6	4.6	5.7	6.9	9.4	12	17	22			
		2,000	2.8	.52	.26	.11	.04	.02	70	98	124	176	226			81	81	81	81	80	80	78	78			
		3,500		.90	.45	.19	.07	.03								5.0	6.0	7.0	8.3	11	13	18	23			
		5,000	3.3	1.29	.64	.27	.09	.04	72	100	126	180	230			81	81	81	81	80	80	79	79			
		7,500		1.93	.95	.40	.14	.06								6.0	7.0	8.1	9.3	12	14	19	24			
		10,000	3.9	2.58	1.27	.53	.18	.07	74	102	128	184	232			81	81	81	81	81	80	79	79			
		15,000		3.87	1.90	.80	.27	.11								7.1	8.4	9.5	11	13	16	21	25			
		20,000	4.4	5.16	2.53	1.06	.36	.15	76	104	130	188	236			81	81	81	81	80	80	80	79			
		25,000		6.44	3.17	1.33	.45	.18								8.3	9.7	11	12	15	17	22	27			
50,000	6.9	12.9	6.33	2.66	.90	.36	84	116	142	204	246			81	81	81	81	80	80	80	79					
75,000		19.4	9.49	3.98	1.35	.55								12	14	16	17	20	23	26	31					
100,000																										
150,000																										
200,000																										
250,000																										

(NOTE) For speeds not shown on the pump hydraulic charts, consult factory.



NM

PUMP HYDRAULIC SIZE CHART

SEC. 500

Page 96

January 2010

**48 GPM
350 RPM**

NOMINAL		ROTOR TRIM	VISCOSITY (SSU)	N.I.P.R. (PSIA)	FRICTION PIPE LOSS (PSI/FT) <small>(Based on Sch 40 Steel Pipe)</small>					FULL BYPASS RELIEF VALVE PRESSURE (PSI)					CAPACITY (GPM) / H.P. REQUIRED														
CAP. GPM	SPEED RPM				PIPE DIAMETER					CRACKING PRESS. (PSI)					DIFFERENTIAL PRESSURE (PSI)														
					2"	2 1/2"	3"	4"	5"	LOW PRES R/V			HI PRES R/V		MEDIUM DUTY AND HEAVY DUTY				HEAVY DUTY ONLY										
							50	75	100	150	200	25	50	75	100	150	200	300	400										
48	350	STD	28	1.3	.01	.01	.01	.01	.01	56	82	108				43	42	40	40										
			32		.02	.01	.01	.01	.01							1.2	2.0	3.0	3.8										
			38	1.3	.02	.01	.01	.01	.01	56	82	108	158				46	45	44	43	42								
			50		.03	.01	.01	.01	.01								1.2	2.0	3.0	3.8	5.2								
			70	1.3	.03	.02	.01	.01	.01	57	83	110	159	210				47	47	46	45	44	42						
			100		.04	.02	.01	.01	.01									1.3	2.1	3.1	3.8	5.2	6.5						
			150	1.3	.04	.02	.01	.01	.01	57	83	110	159	210				48	48	47	46	45	44	43	42				
			200		.04	.02	.01	.01	.01									1.4	2.2	3.1	3.8	5.2	6.5	9.3	12				
			300	1.3	.05	.03	.01	.01	.01	58	84	112	161	212				49	49	48	47	46	45	45	44				
			500		.08	.04	.02	.01	.01									1.6	2.2	3.1	3.9	5.3	6.7	9.6	13				
			750	1.3	.12	.06	.03	.01	.01	58	84	112	161	212				49	49	49	48	47	47	46	46				
			1,000		.16	.08	.04	.01	.01									1.8	2.3	3.1	3.9	5.3	6.8	9.8	13				
		2,000	1.7	.31	.15	.07	.02	.01	60	86	114	164	214				49	49	49	48	48	48	47	47					
		3,500		.54	.27	.11	.04	.02									2.6	3.2	4.0	4.7	6.3	7.6	11	13					
		5,000	2.1	.78	.38	.16	.06	.03	60	86	114	168	216				49	49	49	49	48	48	48	47					
		7,500		1.16	.57	.24	.08	.04									3.1	3.7	4.5	5.2	6.8	8.1	11	14					
		10,000	2.5	1.55	.76	.32	.11	.05	62	88	116	168	218				49	49	49	49	48	48	48	47					
		15,000		2.32	1.14	.48	.16	.07									3.6	4.3	5.0	5.8	7.3	8.7	12	15					
		20,000	3.0	3.09	1.52	.64	.22	.09	62	88	116	170	218				49	49	49	49	48	48	48	47					
		25,000		3.87	1.90	.80	.27	.11									4.2	4.7	5.5	6.3	7.7	9.3	12	15					
		50,000	4.4	7.73	3.80	1.60	.54	.22	64	90	118	172	220				49	49	49	49	48	48	48	47					
		75,000		11.6	5.70	2.39	.81	.33									5.5	6.3	7.0	8.1	9.6	11	14	17					
		100,000	7.8	15.5	7.60	3.19	1.08	.44	68	94	122	176	224				49	49	49	49	48	48	48	47					
		150,000		23.2	11.4	4.78	1.61	.65									7.0	7.8	8.6	10	12	13	16	19					
200,000	12.3	30.9	15.2	6.37	2.15	.87	72	98	127	181	230				49	49	49	49	48	48	48	47							
250,000		38.7	19.0	7.97	2.69	1.09									8.9	9.3	10	12	14	16	18	22							

(NOTE) For speeds not shown on the pump hydraulic charts, consult factory.