

**GHS SERIES
 FLEXIBLE SEAL
 HEAVY DUTY STANDARD
 STAINLESS STEEL ROTARY
 GEAR PUMP**

This heavy duty series with internal “wetted” parts of 316 Stainless Steel is ideal for handling corrosive applications. Superior rotor shaft support and an integral maintenance-free radial/thrust bearing, reduce deflection and wear. Due to the “galling” nature of stainless, extra internal clearance is necessary. A capacity correction table for liquids less than 750 SSU is available in Section 500.

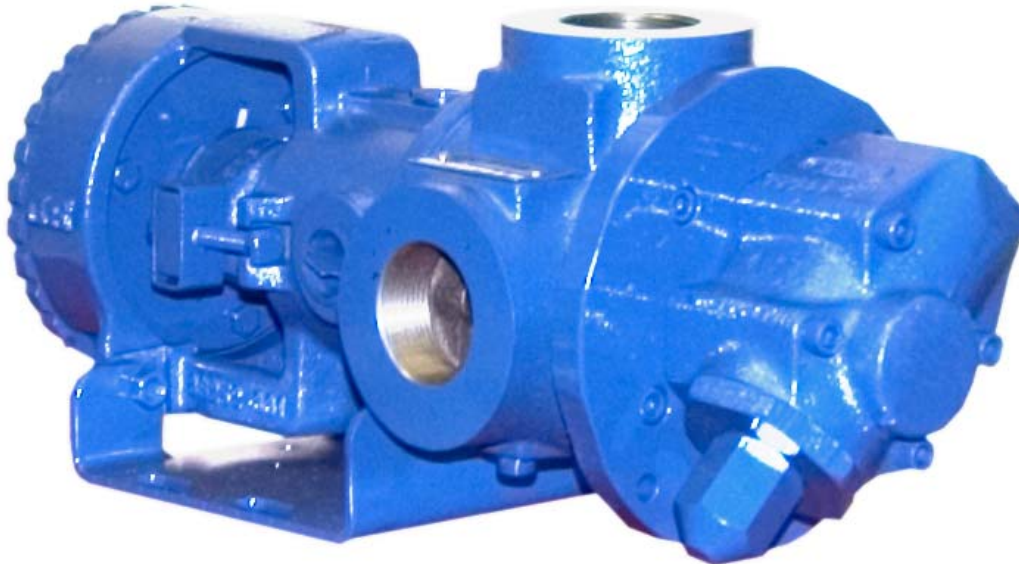

SHOWN ^W/INTERCHANGE FOOT BRACKET

The GHS stainless series is designed for applications in the operating ranges noted below. These units are available with head and backhead jackets for temperature control, silicon carbide bushings for wear resistance, and numerous shaft seal options described on the following pages.

FEATURES

- 200 PSI CAPABILITY
- BALL BEARING THRUST CONTROL
- ROTOR END CLEARANCE EXTERNALLY ADJUSTABLE
- EXCEPTIONAL SEAL VERSATILITY WITH INTERNAL SEAL VENT
- COMPUTER PROFILED GEARING FOR QUIET OPERATION
- MULTIPLE PORT POSITIONS
- FLEXIBLE SEAL DESIGN ALLOWS FOR A VARIETY OF INDUSTRY STANDARD SEALS OR PACKING

OPERATING RANGE

- CAPACITY (GPM): (3 TO 295)
 [LPM] : [11 TO 1116]
- PRESSURE (PSI) : [0 TO 200]
 [BAR] : [0 TO 14]
- VISCOSITY (SSU) : (28 TO 2,000,000)
 [cSt] : [1 TO 440,000]
- TEMPERATURE (F) : (-30° TO 675°)
 [C] : [-34° TO 358°]

APPLICATIONS

- USE WITH ANY CLEAN LIQUID COMPATIBLE WITH 316 STAINLESS STEEL
- ★ BOOSTER SERVICE
 - ★ CIRCULATING
 - ★ FILTERING
 - ★ LUBRICATING
 - ★ TRANSFERRING

EXTERIOR	BACKH.D.	ROTOR & IDLER	HOUSING PORTS	BUSHING	IDLER PIN	SHAFT	SHAFT SEALING		ROTA-TION	INTERNAL RELIEF VALVE	
							MECH. SEAL	PACKING		MATERIAL	SETTING
316 STAIN. STEEL	CAST IRON	316 STAIN. STEEL	GHC 180° FLG. GHS 90° NPT	CARBON GRAPHITE	COATED 316 SST	STAIN. STEEL	CARBON, SIC, TEFLON ENC.	CARBON FIBER	C.W.	316 STAINLESS STEEL	75 PSI [5 BAR]

G H C 1 DC 9 - B
G H S 1 DC 9 - B
 | | | | | | | | | | | |
 GEAR DUTY DESIGN PORT SIZE HYD. SIZE SEAL STYLE

Standard Models

MODEL NUMBER		NOM. CAPACITY - SPEED				MAXIMUM				SHIPPING DATA	
		MAXIMUM		ALTERNATIVE		DIFF. PRESSURE - PSI [BAR]			TEMP.	Wt.	Vol.
		GPM [LPM]	RPM 60 Hz [50 HZ]	GPM [LPM]	RPM 60 Hz [50 HZ]	BELOW 38 SSU [4 cSt]	38 TO 100 SSU [21 cSt]	100 TO 250,000 SSU [55,000 cSt]	°F [°C]		
GHC 1 DC9-B ① ● ▸	GHS 1 DC9-B ① ● ● GHS 1 DC10-B ① ■ ■	9 [28]		6 [19]						32 [14,5]	2.9
GHC 1 DE9-B ① ● ▸	GHS 1 DE9-B ① ● ● GHS 1 DE10-B ① ■ ■	11 [35]		7 [22]						32 [14,5]	2.9
GHC 1-1/2 GC9-B ● ▸	GHS 1-1/2 GC9-B ● ● GHS 1-1/2 GC10-B ■ ■	16 [50]		10 [32]						63 [28,6]	2.9
	GHS 2 GC9-B ● ● GHS 2 GC10-B ■ ■									63 [28,6]	2.9
GHC 1-1/2 GF9-B ● ▸	GHS 1-1/2 GF9-B ● ● GHS 1-1/2 GF10-B ■ ■	23 [73]	1750 [1460]	15 [47]	1150 [960]					GHC ● 350 [177]	63 [28,6] 2.9
	GHS 2 GF9-B ● ● GHS 2 GF10-B ■ ■									GHS ● 400 [204]	63 [28,6] 2.9
GHC 1-1/2 GH9-B ● ▸	GHS 1-1/2 GH9-B ● ● GHS 1-1/2 GH10-B ■ ■	31 [98]		20 [63]		75 [5]	100 [7]	200 [14]		GHS ● 400 [204]	63 [28,6] 2.9
	GHS 2 GH9-B ● ● GHS 2 GH10-B ■ ■									GHS ■ 500 [260]	63 [28,6] 2.9
GHC 1-1/2 GJ9-B ● ▸	GHS 1-1/2 GJ9-B ● ● GHS 1-1/2 GJ10-B ■ ■	38 [120]		25 [79]						500 [260]	63 [28,6] 2.9
	GHS 2 GJ9-B ● ● GHS 2 GJ10-B ■ ■										63 [28,6] 2.9
	GHS 2 JG9-B ● ● GHS 2 JG10-B ■ ■	40 [126]	1150 [960]	30 [95]	870 [725]						161 [73,2] 5.3
GHC 3 JG9-B ● ▸	GHS 3 JG9-B ● ● GHS 3 JG10-B ■ ■										161 [73,2] 5.3
	GHS 2 JJ9-B ● ● GHS 2 JJ10-B ■ ■	56 [177]		42 [133]							161 [73,2] 5.3
GHC 3 JJ9-B ● ▸	GHS 3 JJ9-B ● ● GHS 3 JJ10-B ■ ■										161 [73,2] 5.3

STANDARD MODELS CONTINUED

① 3450 [2875] RPM PERMISSIBLE TO 1,000 SSU [220 cSt.] AND 100 PSI [7 BAR]

● MECHANICAL SEAL
■ PACKING/LIP SEAL

▸ PORTS ARE COMPATIBLE WITH 150# ANSI FLANGES. ALL OTHER PORTS ARE TAPPED NPT FOR ANSI PIPE. OPTIONAL [DIN] FLANGES OR TAPPED [BSP] PORTS ARE AVAILABLE FOR EXPORT MARKET.

NOTE: RECOMMENDED PORT SIZES ARE SHOWN IN **BOLDFACE**. EXAMPLE: **GHC 1 DC9-B**, **GHS 1 DC9-B**

THE GORMAN-RUPP COMPANY • MANSFIELD, OHIO

GORMAN-RUPP OF CANADA LIMITED • ST. THOMAS, ONTARIO, CANADA

Standard Models (Continued)

MODEL NUMBER		NOM. CAPACITY - SPEED				MAXIMUM				SHIPPING DATA	
		MAXIMUM		ALTERNATIVE		DIFF. PRESSURE - PSI [BAR]			TEMP.	Wt.	Vol.
		GPM [LPM]	RPM 60 Hz [50 HZ]	GPM [LPM]	RPM 60 Hz [50 HZ]	BELOW 38 SSU [4 cSt]	38 TO 100 SSU [21 cSt]	100 TO 250,000 SSU [55,000 cSt]	°F [°C]	LBS [KG]	CU. FT.
GHC	GHS 2 JL9-B ●	77 [243]	1150 [960]	58 [133]	870 [725]	75 [5]	100 [7]	200 [14]	161 [73,2]	5.3	
	GHS 2 JL10-B ■										
GHC 3 JL9-B ● †	GHS 3 JL9-B ●	107 [338]	960 [960]	81 [256]	580 [480]	75 [5]	100 [7]	200 [14]	161 [73,2]	5.3	
	GHS 3 JL10-B ■										
GHC	GHS 2 JP9-B ●	107 [338]	960 [960]	81 [256]	580 [480]	75 [5]	100 [7]	200 [14]	161 [73,2]	5.3	
	GHS 2 JP10-B ■										
GHC 3 JP9-B ● †	GHS 3 JP9-B ●	132 [500]	960 [960]	80 [252]	580 [480]	75 [5]	100 [7]	200 [14]	161 [73,2]	5.3	
	GHS 3 JP10-B ■										
GHC	GHS 2 NK9-B ●	99 [375]	960 [960]	60 [189]	580 [480]	75 [5]	100 [7]	200 [14]	180 [81,8]	5.3	
	GHS 2 NK10-B ■										
GHC	GHS 2-1/2 NK9-B ●	132 [500]	960 [960]	80 [252]	580 [480]	75 [5]	100 [7]	200 [14]	180 [81,8]	5.3	
	GHS 2-1/2 NK10-B ■										
GHC	GHS 3 NK9-B ●	165 [624]	960 [960]	99 [312]	580 [480]	75 [5]	100 [7]	200 [14]	180 [81,8]	5.3	
	GHS 3 NK10-B ■										
GHC	GHS 2 NM9-B ●	165 [624]	960 [960]	99 [312]	580 [480]	75 [5]	100 [7]	200 [14]	180 [81,8]	5.3	
	GHS 2 NM10-B ■										
GHC	GHS 2-1/2 NM9-B ●	172 [542]	960 [960]	115 [362]	580 [480]	75 [5]	100 [7]	200 [14]	180 [81,8]	5.3	
	GHS 2-1/2 NM10-B ■										
GHC	GHS 3 NM9-B ●	215 [678]	960 [960]	143 [451]	480 [400]	75 [5]	100 [7]	200 [14]	180 [81,8]	5.3	
	GHS 3 NM10-B ■										
GHC	GHS 2-1/2 NP9-B ●	215 [678]	960 [960]	143 [451]	480 [400]	75 [5]	100 [7]	200 [14]	180 [81,8]	5.3	
	GHS 2-1/2 NP10-B ■										
GHC	GHS 3 NP9-B ●	215 [678]	960 [960]	143 [451]	480 [400]	75 [5]	100 [7]	200 [14]	180 [81,8]	5.3	
	GHS 3 NP10-B ■										
GHC	GHS 2 RM9-B ●	172 [542]	960 [960]	115 [362]	580 [480]	75 [5]	100 [7]	200 [14]	357 [162]	10.7	
	GHS 2 RM10-B ■										
GHC	GHS 2-1/2 RM9-B ● †	215 [678]	960 [960]	143 [451]	480 [400]	75 [5]	100 [7]	200 [14]	357 [162]	10.7	
	GHS 2-1/2 RM10-B ■ †										
GHC	GHS 3 RM9-B ● †	215 [678]	960 [960]	143 [451]	480 [400]	75 [5]	100 [7]	200 [14]	357 [162]	10.7	
	GHS 3 RM10-B ■ †										
GHC	GHS 4 RM9-B ● †	215 [678]	960 [960]	143 [451]	480 [400]	75 [5]	100 [7]	200 [14]	357 [162]	10.7	
	GHS 4 RM10-B ■ †										
GHC	GHS 3 RP9-B ● †	215 [678]	960 [960]	143 [451]	480 [400]	75 [5]	100 [7]	200 [14]	357 [162]	10.7	
	GHS 3 RP10-B ■ †										
GHC	GHS 4 RP9-B ● †	215 [678]	960 [960]	143 [451]	480 [400]	75 [5]	100 [7]	200 [14]	357 [162]	10.7	
	GHS 4 RP10-B ■ †										

STANDARD MODELS CONTINUED

● MECHANICAL SEAL
■ PACKING/LIP SEAL

† PORTS ARE COMPATIBLE WITH 150# ANSI FLANGES. ALL OTHER PORTS ARE TAPPED NPT FOR ANSI PIPE. OPTIONAL [DIN] FLANGES OR TAPPED [BSP] PORTS ARE AVAILABLE FOR EXPORT MARKET.

NOTE: RECOMMENDED PORT SIZES ARE SHOWN IN **BOLDFACE**. EXAMPLE: **GHC 1 DC9-B, GHS 1 DC9-B**

THE GORMAN-RUPP COMPANY • MANSFIELD, OHIO
GORMAN-RUPP OF CANADA LIMITED • ST. THOMAS, ONTARIO, CANADA

MODEL NUMBER		NOM. CAPACITY - SPEED				MAXIMUM				SHIPPING DATA	
		MAXIMUM		ALTERNATIVE		DIFF. PRESSURE - PSI [BAR]			TEMP.	Wt.	Vol.
		GPM [LPM]	RPM 60 Hz [50 HZ]	GPM [LPM]	RPM 60 Hz [50 HZ]	BELOW 38 SSU [4 cSt]	38 TO 100 SSU [21 cSt]	100 TO 250,000 SSU [55,000 cSt]	°F [°C]	LBS [KG]	CU. FT.
GHC	GHS										
	GHS 3 RR9-B ● ▸ GHS 3 RR10-B ■ ▸	255 [804]	720 [600]	170 [536]	480 [400]	75 [5]	100 [7]	200 [14]	GHS ● 400 [204] ■ 500 [260]	357 [162]	10.7
	GHS 4 RR9-B ● ▸ GHS 4 RR10-B ■ ▸			196 [618]						357 [162]	
	GHS 4 RS9-B ● ▸ GHS 4 RS10-B ■ ▸			295 [930]						357 [162]	

▸ PORTS ARE COMPATIBLE WITH 150# ANSI STAINLESS STEEL FLANGES. ALL OTHER PORTS ARE TAPPED NPT FOR ANSI PIPE. OPTIONAL [DIN] FLANGES OR TAPPED [BSP] PORTS AVAILABLE FOR EXPORT MARKET.

NOTE: RECOMMENDED PORT SIZES ARE SHOWN IN BOLDFACE. EXAMPLE: **GHC 1 DC9-B, GHS 1 DC9-B**

APPLICATION RECOMMENDATIONS:		
APPLICATION	OPTIONS REQUIRED (Select One From Each Row)	OPERATING LIMITATIONS
GHS ONLY HIGH TEMPERATURE	25U, 25V, OR 25W 35J – 35M (AS REQ'D) 40R, 70K 61H OR 65Q	TEMPERATURE: 675 °F MAX. PRESSURE: 200 PSI MAX.
GHS ONLY JACKETED	40K, 40W, 41U, 41W	LIMIT JACKET PRESSURE TO 150 PSI

NOTE: PROPER PUMP APPLICATION REQUIRES CONSIDERATION OF ADDITIONAL FACTORS. PLEASE REVIEW APPLICATION GUIDE IN SECTION 500 OR CONSULT THE FACTORY.

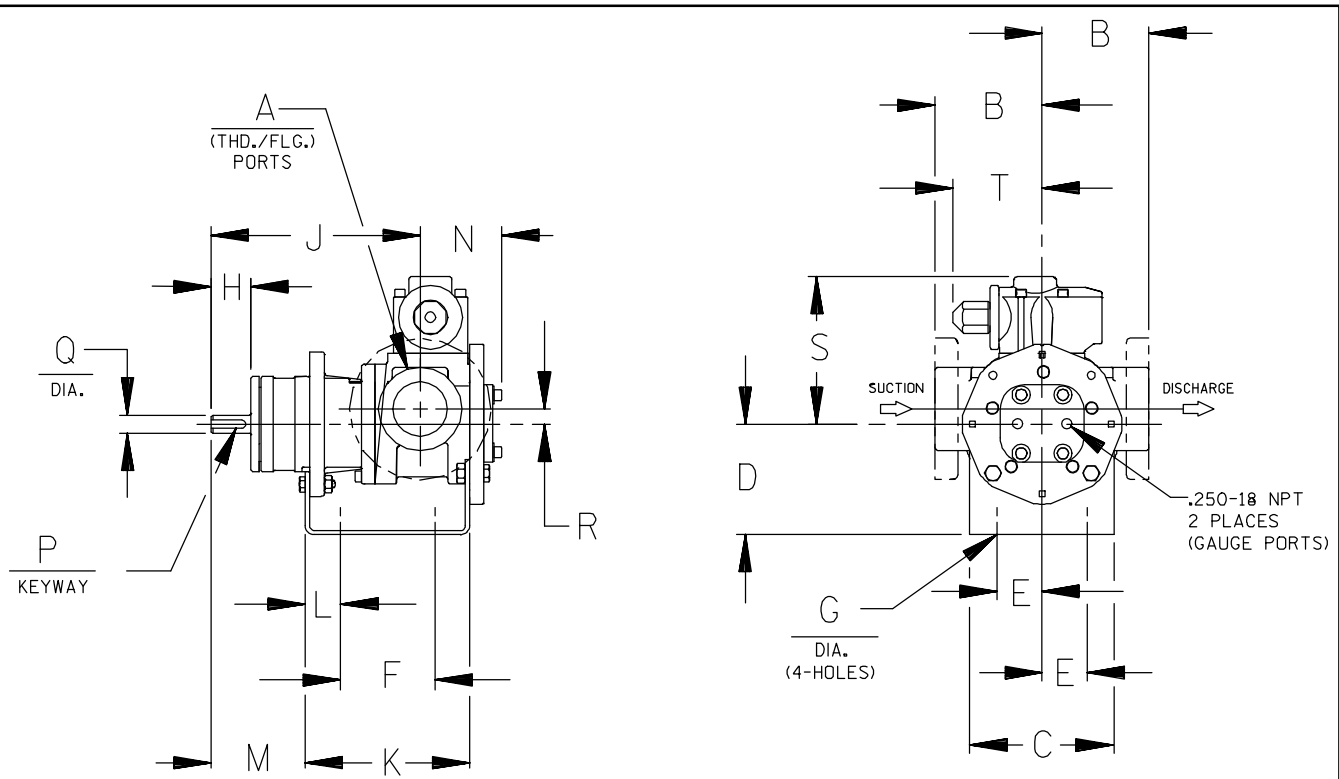

CAD FILE NO.: 16458B

MODEL NUMBERS	PUMP DIMENSIONS - INCHES [MILLIMETERS]																	
	A	B	C	D	E	F	G	H	J	K	L	M	N	P	Q	R	S	T
GHC D	1"	2.50 [64] †	4.00 [102]	3.50* [89]	1.62 [41]	3.12 [79]	.41 [10]	1.16 [30]	6.19 [157]	5.04 [128]	.76 [19]	2.62 [66]	2.74 [70]	.12 [3]	.50 [13]	.62 [16]	5.19 [132]	3.58 [91]
		4.00* [102] †		5.25 [133]										.75 [19]				
GHC G	1-1/2"	3.50 [89] †	5.88 [149]	3.50* [89]	1.62 [41]	4.00 [102]	.41 [10]	1.62 [41]	8.50 [216]	6.71 [170]	1.06 [27]	3.82 [97]	3.35 [85]	.19 [5]	.75 [19]	.62 [16]	6.00 [152]	3.62 [92]
		4.00* [102] †		4.50 [114]										5.25 [133]				
GHC J	3"	4.50 [114] †	6.88 [175]	4.50 [114]	2.88 [73]	4.25 [108]	.44 [11]	2.50 [64]	12.12 [308]	9.75 [248]	1.75 [44]	5.50 [140]	4.66 [118]	.25 [6]	1.00 [25]	1.12 [28]	9.06 [230]	6.75 [171]
		6.00* [152] †		5.25* [133]										6.25 [159]				

* STANDARD DIMENSION

† PORTS ARE COMPATIBLE WITH 125* OR 250* ANSI CAST IRON FLANGES. ALL OTHER PORTS ARE TAPPED NPT FOR ANSI PIPE. OPTIONAL (DIN) FLANGES OR TAPPED (BSP) PORTS AVAILABLE FOR EXPORT MARKET.

† 90° HOUSING

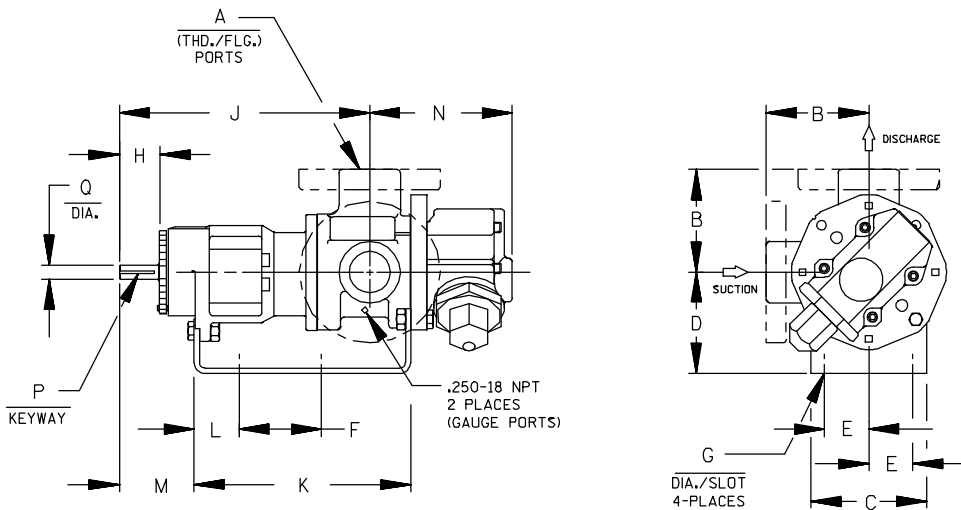

CAD FILE NO.: 16669G

MODEL NUMBERS	PUMP DIMENSIONS - INCHES [MILLIMETERS]														
	A	B	C	D	E	F	G	H	J	K	L	M	N	P	Q
GHS D	1"	2.50* [641]	4.00 [102]	3.50* [891]	1.62 [41]	5.50 [140]	.41 [10]	1.16 [30]	8.43 [214]	7.54 [192]	1.09 [28]	2.29 [58]	4.98 [127]	.12 [3] x .75 [19]	.50 [13]
		4.00 † [102]		5.25 [133]											
GHS G	1-1/2" 2"	3.50* [891]	4.88 [124]	3.50* [891]	1.62 [41]	8.00 [203]	.41 [10]	1.62 [41]	12.06 [306]	10.72 [272]	1.52 [39]	3.35 [85]	5.70 [145]	.19 [5] x 1.25 [32]	.75 [19]
		4.00 † [102]		5.25 [133]											
GHS J	2" 3"	4.50* [114]	6.88 [175]	5.25* [133]	2.88 [73]	10.00 [254]	.44 [11]	2.50 [64]	15.68 [398]	14.31 [363]	2.77 [70]	4.48 [114]	8.50 [216]	.25 [6] x 2.00 [51]	1.00 [25]
		6.00 † [152]		6.25 [159]											
GHS N	2" 3"	5.12 [130]	8.00 [203]	4.50 [114]	2.88 [73]	10.00 [254]	.44 [11]	2.58 [66]	16.37 [416]	15.14 [385]	2.69 [68]	4.56 [116]	8.72 [221]	.25 [6] x 2.00 [51]	1.12 [28]
				5.25* [133]											
GHS R	2"	6.50 [165]	10.50 [267]	7.00 [178]	3.75 [95]	13.75 [349]	.52 [13]	2.25 [57]	17.87 [454]	17.36 [441]	1.86 [47]	4.70 [119]	11.31 [287]	.38 [10] x 1.88 [48]	1.44 [37]
	2-1/2"														
	3"														
	4"	7.19 † [183]													

* STANDARD DIMENSION

† PORTS ARE COMPATIBLE WITH 150# OR 300# ANSISTAINLESS STEEL FLANGES. ALL OTHER PORTS ARE TAPPED NPT FOR ANSI PIPE. OPTIONAL (DIN) FLANGES OR TAPPED (BSP) PORTS AVAILABLE FOR EXPORT MARKET.

‡ 180° HOUSING

GHC/GHS

FOR GHC DRIVE OPTIONS

AND DIMENSIONS

SEE SECTION 540

FOR GHS DRIVE OPTIONS

AND DIMENSIONS

SEE SECTION 545



PERFORMANCE CURVES

SPEED VS. CAPACITY/HORSEPOWER

JL

Hydraulic Size

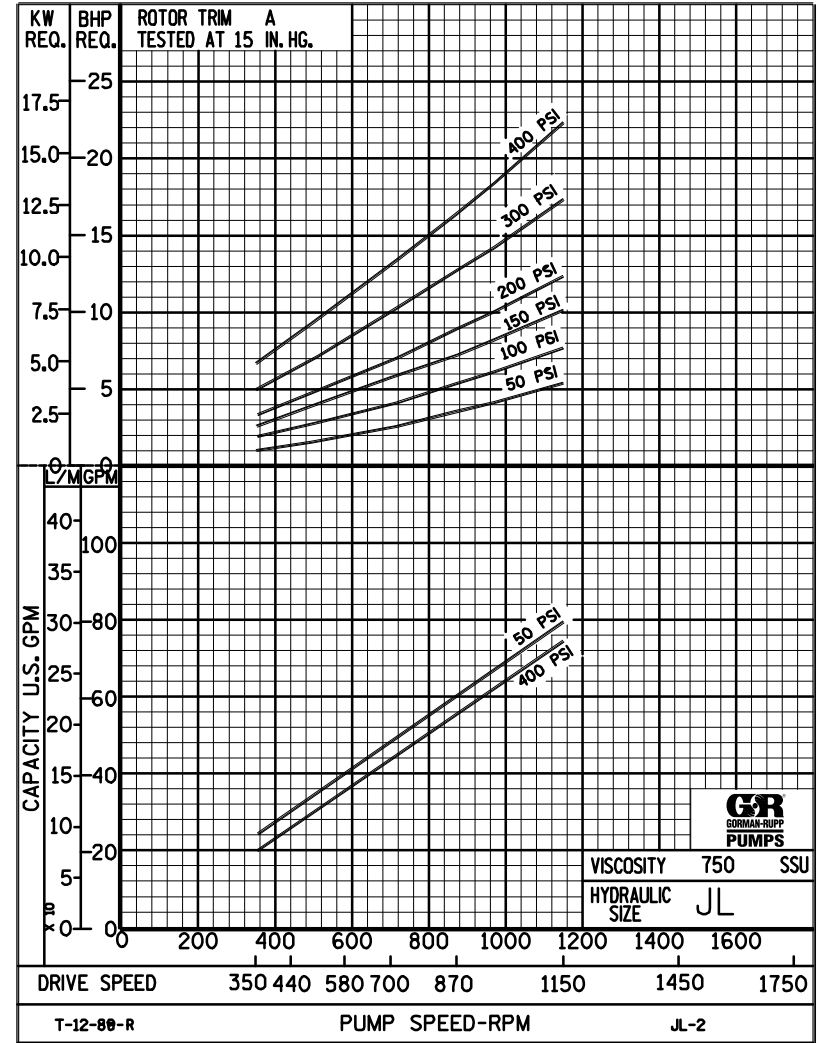
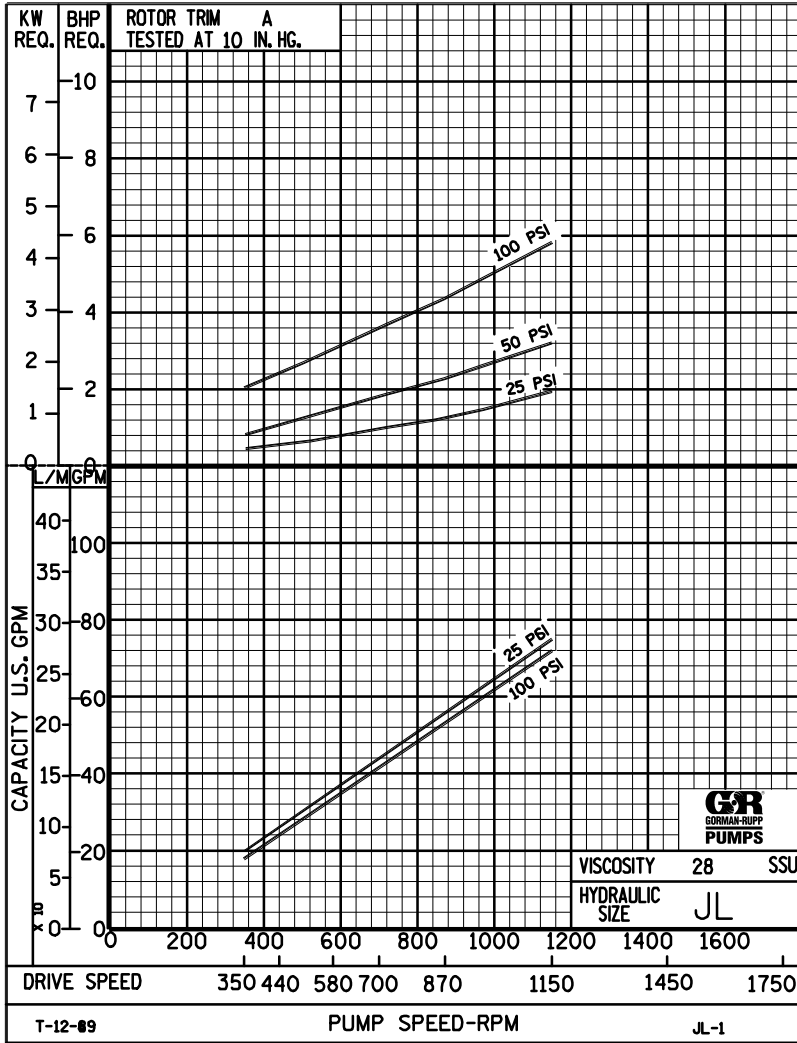

THE GORMAN-RUPP COMPANY • MANSFIELD, OHIO
 GORMAN-RUPP OF CANADA LIMITED • ST. THOMAS, ONTARIO, CANADA



PERFORMANCE CURVES

SPEED VS. CAPACITY/HORSEPOWER

JL Hydraulic Size

SEC. 500

Page 75

January 2010

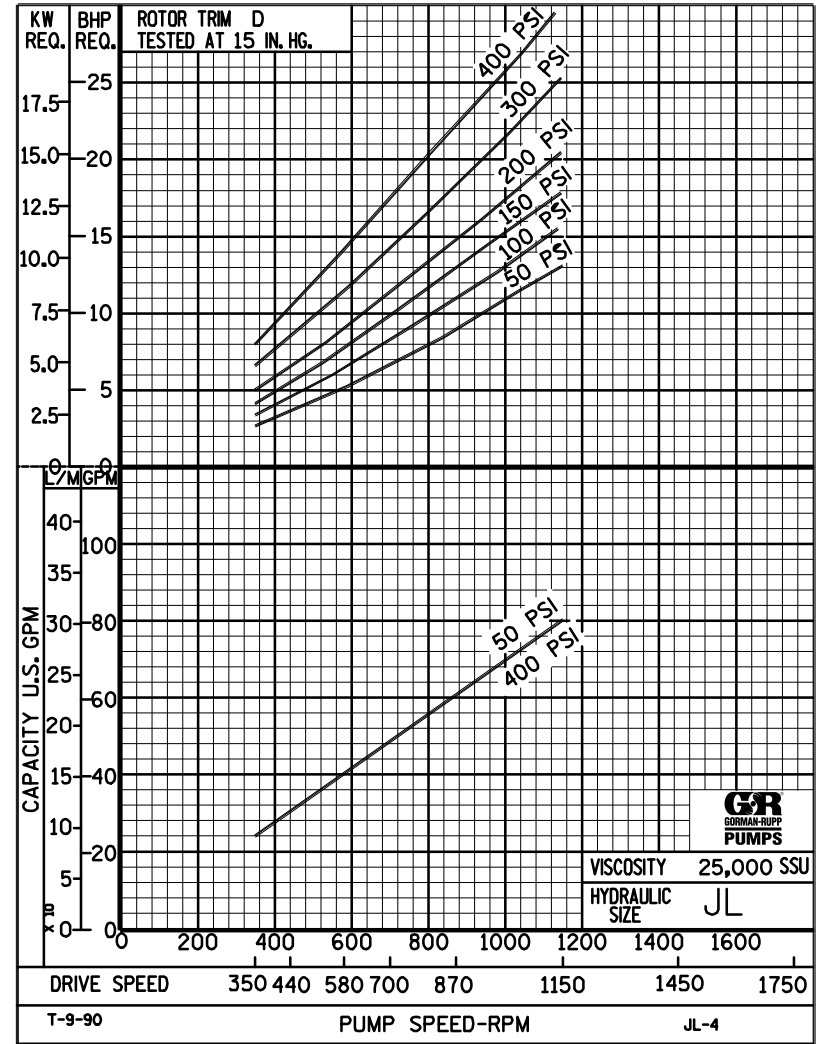
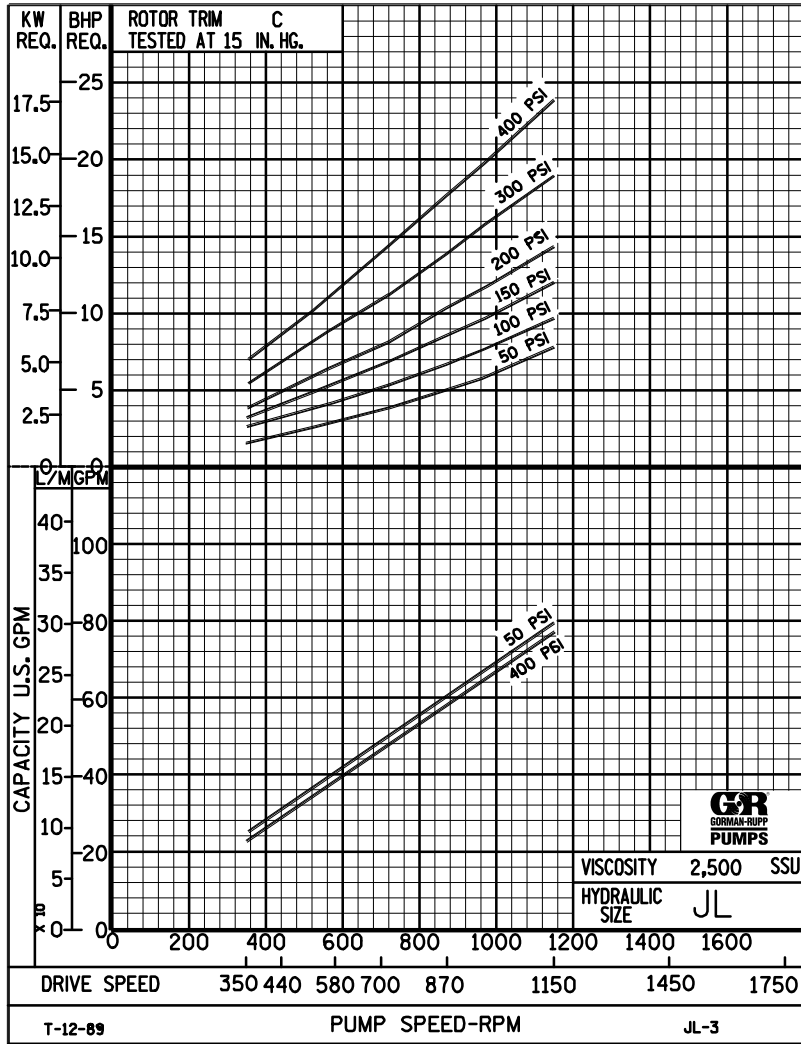

THE GORMAN-RUPP COMPANY • MANSFIELD, OHIO
 GORMAN-RUPP OF CANADA LIMITED • ST. THOMAS, ONTARIO, CANADA

Printed in U.S.A.



JL

PUMP HYDRAULIC SIZE CHART

SEC. 500

Page 76

January 2010

77 GPM
1150 RPM

NOMINAL		ROTOR TRIM	VISCOSITY (SSU)	N.I.P.R. (PSIA)	FRICTION PIPE LOSS (PSI/FT) (Based on Sch 40 Steel Pipe)					FULL BYPASS RELIEF VALVE PRESSURE (PSI)					CAPACITY (GPM) / H.P. REQUIRED																
CAP. GPM	SPEED RPM				PIPE DIAMETER					CRACKING PRESS. (PSI)					DIFFERENTIAL PRESSURE (PSI)																
					1½"	2"	2½"	3"	4"	LOW PRES R/V			HI PRES R/V		25	50	75	100	150	200	300	400									
77	1150	STD	28	4.3	.01	.01	.01	.01	.01	73	99	132				75	73	72	72												
			32		.13	.04	.02	.01	.01							2.0	3.2	4.5	5.8												
			38	4.3	.16	.05	.02	.01	.01	73	99	132	173				76	74	74	73	72										
			50		.19	.06	.03	.01	.01								2.1	3.4	4.7	6.0	8.8										
			70	4.3	.22	.07	.03	.01	.01	73	100	133	173	225			77	76	75	75	74	73									
			100		.25	.08	.03	.01	.01								2.4	3.7	5.0	6.2	9.0	12									
			150	4.3	.28	.09	.04	.02	.01	74	100	133	174	225			78	77	77	76	76	75	72	70							
			200		.31	.10	.04	.02	.01								2.7	4.1	5.3	6.5	9.1	12	17	22							
			300	4.3	.35	.11	.04	.02	.01	74	101	134	174	226			79	78	78	77	77	76	74	72							
			500		.38	.13	.06	.03	.01								3.6	4.9	6.0	7.6	9.8	12	17	22							
			750	4.3	.51	.19	.09	.04	.02	74	101	134	174	226			79	79	79	79	78	77	75	74							
			1,000		.68	.25	.12	.05	.02								4.2	5.4	6.6	7.7	10	12	17	22							
		2,000	4.8	1.35	.50	.25	.10	.04	75	103	136	176	228			79	79	79	79	79	78	77	76								
		3,500		2.36	.87	.43	.18	.06								6.3	7.4	8.5	9.7	12	14	19	24								
		5,000	5.1	3.37	1.24	.61	.26	.09	79	108	138	178	230			80	79	79	79	79	79	78	77								
		7,500		5.06	1.86	.92	.39	.13								8.4	9.5	11	12	14	17	21	26								
		10,000	5.5	6.74	2.48	1.22	.51	.17	83	113	142	182	234			80	80	79	79	79.5	79	78	78								
		15,000		10.1	3.72	1.83	.77	.26								10	12	12	14	17	19	23	28								
		20,000	5.8	13.5	4.96	2.44	1.02	.35	88	119	148	186	240			80	80	80	79	79	79	79	79								
		25,000		16.9	6.20	3.05	1.28	.43								12	13	14	16	18	21	25	30								
		50,000	8.1	33.7	12.4	6.09	2.56	.86	94	125	154	192	246			80	80	79	79	79	79	78	78								
		75,000		-	-	-	-	-								16	18	21	23	25	27	30	35								
		100,000																													
		150,000																													
200,000																															
250,000																															

(NOTE) For speeds not shown on the pump hydraulic charts, consult factory.



JL

PUMP HYDRAULIC SIZE CHART

SEC. 500

**58 GPM
870 RPM**

NOMINAL		ROTOR TRIM	VISCOSITY (SSU)	N.I.P.R. (PSIA)	FRICTION PIPE LOSS (PSI/FT) <small>(Based on Sch 40 Steel Pipe)</small>					FULL BYPASS RELIEF VALVE PRESSURE (PSI)					CAPACITY (GPM) / H.P. REQUIRED											
CAP. GPM	SPEED RPM				PIPE DIAMETER					CRACKING PRESS. (PSI)					DIFFERENTIAL PRESSURE (PSI)											
					1½"	2"	2½"	3"	4"	LOW PRES R/V			HI PRES R/V		MEDIUM DUTY AND HEAVY DUTY				HEAVY DUTY ONLY							
58	870	STD	28	2.8	.01	.01	.01	.01	.01	63	88	115			55	54	54	53								
			32		.08	.03	.01	.01	.01						1.2	2.3	3.3	4.4								
			38	2.8	.10	.03	.02	.01	.01	63	90	117	167			56	56	55	54	53						
			50		.12	.04	.02	.01	.01							1.3	2.5	3.5	4.5	6.7						
			70	2.8	.14	.04	.02	.01	.01	64	91	119	168	220			58	57	56	56	55	53				
			100		.15	.05	.02	.01	.01								1.3	2.6	3.6	4.5	6.7	8.7				
			150	2.8	.18	.06	.03	.01	.01	65	92	121	168	220			59	58	58	57	57	56	54	52		
			200		.19	.06	.03	.01	.01								1.5	2.9	3.8	4.7	6.9	8.7	12	16		
			300	2.8	.21	.06	.03	.01	.01	66	93	123	169	221			59	59	59	58	58	57	56	55		
			500		.26	.10	.05	.02	.01								1.8	3.4	4.1	5.1	7.0	8.8	13	16		
		750	2.8	.38	.14	.07	.03	.01	67	94	125	169	221			60	60	60	59	58	58	58	57			
		1,000		.51	.19	.09	.04	.02								3.0	3.5	4.4	5.3	7.1	8.9	13	16			
		2,000	3.4	1.02	.38	.19	.08	.03	71	96	125	169	223			60	60	60	60	60	59	58	58			
		3,500		1.78	.66	.32	.14	.05								4.4	5.0	5.8	6.7	8.6	10	14	18			
		5,000	3.7	2.54	.94	.46	.19	.07	73	98	127	171	225			60	60	60	60	60	60	59	58			
		7,500		3.81	1.40	.69	.29	.10								5.7	6.7	7.6	8.6	11	12	15	20			
		10,000	4.1	5.08	1.87	.92	.39	.13	75	100	129	173	227			60	60	60	60	60	60	59	58			
		15,000		7.61	2.80	1.38	.58	.20								6.8	8.0	9.0	9.8	12	13	17	21			
		20,000	4.4	10.2	3.74	1.84	.77	.26	79	104	129	175	227			60	60	60	60	60	59	59	58			
		25,000		12.7	4.67	2.30	.96	.33								8.2	8.9	9.8	11	13	15	18	22			
50,000	6.6	25.4	9.34	4.59	1.93	.65	83	108	133	179	231			60	60	60	60	60	59	59	58					
75,000		38.1	14.0	6.88	2.89	.98								10	11	13	14	16	18	22	26					
100,000	9.0	50.8	18.7	9.18	3.85	1.30	87	112	137	183	235			60	60	60	60	60	59	59	58					
150,000		-	-	-	-	-								12	14	15	16	19	21	25	29					
200,000																										
250,000																										

(NOTE) For speeds not shown on the pump hydraulic charts, consult factory.



JL

PUMP HYDRAULIC SIZE CHART

SEC. 500

Page 78

January 2010

**38 GPM
580 RPM**

NOMINAL		ROTOR TRIM	VISCOSITY (SSU)	N.I.P.R. (PSIA)	FRICTION PIPE LOSS (PSI/FT) <small>(Based on Sch 40 Steel Pipe)</small>					FULL BYPASS RELIEF VALVE PRESSURE (PSI)					CAPACITY (GPM) / H.P. REQUIRED								
CAP. GPM	SPEED RPM				PIPE DIAMETER					CRACKING PRESS. (PSI)					DIFFERENTIAL PRESSURE (PSI)								
					1½"	2"	2½"	3"	4"	LOW PRES R/V			HI PRES R/V		MEDIUM DUTY AND HEAVY DUTY				HEAVY DUTY ONLY				
							50	75	100	150	200	25	50	75	100	150	200	300	400				
38	580	STD	28	1.8	.01	.01	.01	.01	.01	58	83	115				36	35	35	34				
			32		.04	.01	.01	.01	.01							.82	1.5	2.2	2.9				
			38	1.8	.05	.02	.01	.01	.01	58	83	115	159			37	36	35	35	33			
			50		.06	.02	.01	.01	.01							.88	1.6	2.3	2.9	4.3			
			70	1.8	.07	.02	.01	.01	.01	58	83	115	159	211		38	37	37	36	35	34		
			100		.08	.02	.01	.01	.01							.91	1.6	2.3	3.0	4.3	5.5		
			150	1.8	.09	.02	.01	.01	.01	59	84	117	159	211		39	38	38	37	37	36	35	32
			200		.09	.03	.01	.01	.01							1.1	1.7	2.4	3.0	4.4	5.5	8.2	11
			300	1.8	.10	.04	.02	.01	.01	59	86	117	159	211		39	39	38	38	37	37	36	35
			500		.17	.06	.03	.02	.01							1.3	1.9	2.8	3.2	4.4	5.6	8.3	11
		750	1.8	.25	.09	.05	.02	.01	59	86	117	159	211		40	39	39	39	38	38	38	37	
		1,000		.33	.12	.06	.03	.01							1.7	2.4	3.1	3.6	4.7	5.8	8.4	11	
		2,000	2.4	.67	.25	.12	.05	.02	61	88	119	161	213		40	40	39	39	39	39	38	38	
		3,500		1.17	.43	.21	.09	.03							2.8	3.3	4.0	4.6	5.7	6.8	9.2	12	
		5,000	2.8	1.66	.61	.30	.13	.05	63	90	121	161	213		40	40	40	40	39	39	39	39	
		7,500		2.50	.92	.45	.19	.07							3.4	3.9	4.6	5.3	6.4	7.5	9.9	12	
		10,000	3.1	3.33	1.23	.60	.25	.09	65	92	124	161	215		40	40	40	40	39	39	39	39	
		15,000		4.99	1.84	.90	.38	.13							4.0	4.5	5.2	5.9	7.0	8.3	11	13	
		20,000	3.5	6.65	2.45	1.20	.51	.17	67	94	127	161	215		40	40	40	40	39	39	39	39	
		25,000		8.31	3.06	1.51	.63	.22							4.5	5.0	5.7	6.4	7.6	8.9	11	14	
50,000	5.4	16.6	6.12	3.01	1.26	.43	71	98	131	165	219		40	40	40	40	39	39	39	39			
75,000		24.9	9.18	4.51	1.89	.64							5.9	6.5	7.2	8.0	9.1	11	14	17			
100,000	7.8	33.3	12.3	6.01	2.52	.85	75	102	135	169	223		40	40	40	40	39	39	39	39			
150,000		49.9	18.4	9.02	3.78	1.28							7.2	7.8	8.7	9.8	11	13	16	20			
200,000																							
250,000																							

(NOTE) For speeds not shown on the pump hydraulic charts, consult factory.

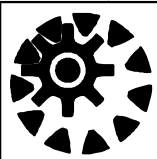

JL

PUMP HYDRAULIC SIZE CHART

SEC. 500

Page 79
January 2010

**23 GPM
350 RPM**

NOMINAL		ROTOR TRIM	VISCOSITY (SSU)	N.I.P.R. (PSIA)	FRICTION PIPE LOSS (PSI/FT) (Based on Sch 40 Steel Pipe)					FULL BYPASS RELIEF VALVE PRESSURE (PSI)					CAPACITY (GPM) / H.P. REQUIRED													
CAP. GPM	SPEED RPM				PIPE DIAMETER					CRACKING PRESS. (PSI)					DIFFERENTIAL PRESSURE (PSI)													
					1½"	2"	2½"	3"	4"	LOW PRES R/V			HI PRES R/V		MEDIUM DUTY AND HEAVY DUTY				HEAVY DUTY ONLY									
23	350	STD	28	1.4	.01	.01	.01	.01	.01	55	81	111			21	21	21	20										
			32		.02	.01	.01	.01	.01						.52	.85	1.3	1.8										
			38	1.4	.02	.01	.01	.01	.01	55	81	111	158			22	22	21	21	20								
			50		.03	.01	.01	.01	.01							.58	.90	1.4	1.8	2.6								
			70	1.4	.03	.01	.01	.01	.01	55	81	111	158	209			22	22	22	21	21	20						
			100		.03	.01	.01	.01	.01								.64	.98	1.4	1.8	2.6	3.3						
			150	1.4	.03	.01	.01	.01	.01	56	82	111	158	209			23	23	22	22	22	21	21	20				
			200		.04	.02	.01	.01	.01								.68	1.1	1.4	1.9	2.6	3.3	4.8	6.3				
			300	1.4	.06	.03	.01	.01	.01	56	82	111	158	209			23	23	23	23	22	22	21	21				
			500		.10	.04	.02	.01	.01								.80	1.2	1.6	1.9	2.7	3.3	4.8	6.4				
		750	1.4	.15	.06	.03	.01	.01	56	82	111	158	209			24	23	23	23	23	23	22	22					
		1,000		.20	.08	.04	.02	.01								1.1	1.5	1.8	2.1	2.8	3.5	5.0	6.6					
		2,000	1.8	.40	.15	.08	.03	.01	57	83	112	159	210			24	24	23	23	23	23	23	23					
		3,500		.71	.26	.13	.06	.02								1.6	2.1	2.3	2.7	3.5	4.2	5.5	7.1					
		5,000	2.2	1.01	.37	.18	.08	.03	58	84	113	160	211			24	24	24	24	23	23	23	23					
		7,500		1.51	.56	.28	.12	.04								2.0	2.4	2.7	3.1	3.8	4.6	5.8	7.5					
		10,000	2.6	2.01	.74	.37	.16	.05	59	86	114	161	212			24	24	24	24	23	23	23	23					
		15,000		3.02	1.11	.55	.23	.08								2.4	2.8	3.2	3.6	4.3	5.0	6.4	7.9					
		20,000	2.9	4.03	1.48	.73	.31	.11	61	88	115	161	212			24	24	24	24	24	23	23	23					
		25,000		5.03	1.85	.91	.38	.13								2.7	3.2	3.5	3.9	4.5	5.3	6.8	8.3					
50,000	4.6	10.1	3.71	1.82	.77	.26	63	90	117	163	214			24	24	24	24	24	23	23	23							
75,000		15.1	5.56	2.73	1.15	.39								3.6	4.0	4.4	4.9	5.6	6.5	8.2	9.8							
100,000	6.6	20.1	7.41	3.64	1.53	.52	66	93	120	166	217			24	24	24	24	24	23	23	23							
150,000		30.2	11.1	5.46	2.29	.77								4.3	4.8	5.3	5.8	6.5	7.7	9.5	11							
200,000	10.2	40.3	14.8	7.28	3.05	1.03	69	96	123	169	220			24	24	24	24	24	23	23	23							
250,000		-	-	-	-	-								4.9	5.7	6.1	6.7	7.5	9.2	11	13							

(NOTE) For speeds not shown on the pump hydraulic charts, consult factory.