

**GHC SERIES
 HEAVY DUTY COMPACT
 STAINLESS STEEL ROTARY
 GEAR PUMP**

This heavy duty series with internal “wetted” parts of 316 Stainless Steel is ideal for handling corrosive applications. Superior rotor shaft support and an integral maintenance-free radial/thrust bearing, reduce deflection and wear. Due to the “galling” nature of stainless, extra internal clearance is necessary. A capacity correction table for liquids less than 750 SSU is available in Section 500.

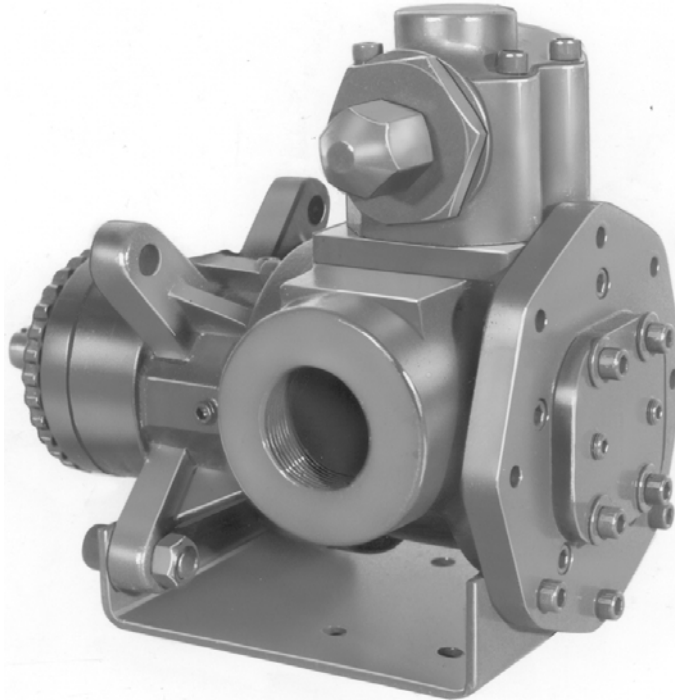

SHOWN ^W/OPTIONAL THREADED PORTS

The GHC stainless series is designed for applications in the operating ranges noted on the model pages. These units are available with head jackets for temperature control, silicon carbide bushings for wear resistance, and numerous shaft seal options described on the following pages. These units may be foot mounted or, by using a motor adaptor, direct connected to NEMA “C” flange motors.

FEATURES

- 200 PSI CAPABILITY
- BALL BEARING THRUST CONTROL
- ROTOR END CLEARANCE EXTERNALLY ADJUSTABLE
- EXCEPTIONAL SEAL VERSATILITY WITH INTERNAL SEAL VENT
- COMPUTER PROFILED GEARING FOR QUIET OPERATION
- MULTIPLE PORT POSITIONS

OPERATING RANGE

CAPACITY	(GPM):	(3 TO 107)
	[LPM]:	[11 TO 405]
PRESSURE	(PSI):	[0 TO 200]
	[BAR]:	[0 TO 14]
VISCOSITY	(SSU):	(28 TO 25,000)
	[cSt]:	[1 TO 5417]
TEMPERATURE (F)	:	(-30° TO 350°)
	[C]:	[-34° TO 177°]

APPLICATIONS

USE WITH ANY CLEAN LIQUID COMPATIBLE WITH 316 STAINLESS STEEL

- ★ BOOSTER SERVICE
- ★ CIRCULATING
- ★ FILTERING
- ★ LUBRICATING
- ★ TRANSFERRING

EXTERIOR	BACKH.D	ROTOR & IDLER	HOUSING PORTS	BUSHING	IDLER PIN	SHAFT	SHAFT SEALING		ROTA-TION	INTERNAL RELIEF VALVE	
							MECH. SEAL	PACKING		MATERIAL	SETTING
316 STAIN. STEEL	CAST IRON	316 STAIN. STEEL	GHC 180° FLG. GHS 90° NPT	CARBON GRAPHITE	COATED 316 SST	STAIN. STEEL	CARBON, SIC, TEFLON ENC.	CARBON FIBER	C.W.	316 STAINLESS STEEL	75 PSI [5 BAR]

G H C 1 DC 9 - B
G H S 1 DC 9 - B
 | | | | | | | | | | | |
 GEAR DUTY DESIGN PORT SIZE HYD. SIZE SEAL STYLE

Standard Models

MODEL NUMBER		NOM. CAPACITY - SPEED				MAXIMUM				SHIPPING DATA	
		MAXIMUM		ALTERNATIVE		DIFF. PRESSURE - PSI [BAR]			TEMP.	Wt.	Vol.
		GPM [LPM]	RPM 60 Hz [50 HZ]	GPM [LPM]	RPM 60 Hz [50 HZ]	BELOW 38 SSU [4 cSt]	38 TO 100 SSU [21 cSt]	100 TO 250,000 SSU [55,000 cSt]	°F [°C]		
GHC 1 DC9-B ① ● ▸	GHS 1 DC9-B ① ● ● GHS 1 DC10-B ① ■ ■	9 [28]		6 [19]						32 [14,5]	2.9
GHC 1 DE9-B ① ● ▸	GHS 1 DE9-B ① ● ● GHS 1 DE10-B ① ■ ■	11 [35]		7 [22]						32 [14,5]	2.9
GHC 1-1/2 GC9-B ● ▸	GHS 1-1/2 GC9-B ● ● GHS 1-1/2 GC10-B ■ ■	16 [50]		10 [32]						63 [28,6]	2.9
	GHS 2 GC9-B ● ● GHS 2 GC10-B ■ ■									63 [28,6]	2.9
GHC 1-1/2 GF9-B ● ▸	GHS 1-1/2 GF9-B ● ● GHS 1-1/2 GF10-B ■ ■	23 [73]	1750 [1460]	15 [47]	1150 [960]					GHC ● 350 [177]	63 [28,6] 2.9
	GHS 2 GF9-B ● ● GHS 2 GF10-B ■ ■									GHS ● 400 [204]	63 [28,6] 2.9
GHC 1-1/2 GH9-B ● ▸	GHS 1-1/2 GH9-B ● ● GHS 1-1/2 GH10-B ■ ■	31 [98]		20 [63]		75 [5]	100 [7]	200 [14]		GHS ● 400 [204]	63 [28,6] 2.9
	GHS 2 GH9-B ● ● GHS 2 GH10-B ■ ■									■ 63 [28,6]	2.9
GHC 1-1/2 GJ9-B ● ▸	GHS 1-1/2 GJ9-B ● ● GHS 1-1/2 GJ10-B ■ ■	38 [120]		25 [79]						500 [260]	63 [28,6] 2.9
	GHS 2 GJ9-B ● ● GHS 2 GJ10-B ■ ■										63 [28,6] 2.9
	GHS 2 JG9-B ● ● GHS 2 JG10-B ■ ■	40 [126]	1150 [960]	30 [95]	870 [725]						161 [73,2] 5.3
GHC 3 JG9-B ● ▸	GHS 3 JG9-B ● ● GHS 3 JG10-B ■ ■										161 [73,2] 5.3
	GHS 2 JJ9-B ● ● GHS 2 JJ10-B ■ ■	56 [177]		42 [133]							161 [73,2] 5.3
GHC 3 JJ9-B ● ▸	GHS 3 JJ9-B ● ● GHS 3 JJ10-B ■ ■										161 [73,2] 5.3

STANDARD MODELS CONTINUED

① 3450 [2875] RPM PERMISSIBLE TO 1,000 SSU [220 cSt.] AND 100 PSI [7 BAR]

● MECHANICAL SEAL
■ PACKING/LIP SEAL

▸ PORTS ARE COMPATIBLE WITH 150# ANSI FLANGES. ALL OTHER PORTS ARE TAPPED NPT FOR ANSI PIPE. OPTIONAL [DIN] FLANGES OR TAPPED [BSP] PORTS ARE AVAILABLE FOR EXPORT MARKET.

NOTE: RECOMMENDED PORT SIZES ARE SHOWN IN **BOLDFACE**. EXAMPLE: **GHC 1 DC9-B**, **GHS 1 DC9-B**

THE GORMAN-RUPP COMPANY • MANSFIELD, OHIO

GORMAN-RUPP OF CANADA LIMITED • ST. THOMAS, ONTARIO, CANADA

Standard Models (Continued)

MODEL NUMBER		NOM. CAPACITY - SPEED				MAXIMUM				SHIPPING DATA	
		MAXIMUM		ALTERNATIVE		DIFF. PRESSURE - PSI [BAR]			TEMP.	Wt.	Vol.
		GPM [LPM]	RPM 60 Hz [50 HZ]	GPM [LPM]	RPM 60 Hz [50 HZ]	BELOW 38 SSU [4 cSt]	38 TO 100 SSU [21 cSt]	100 TO 250,000 SSU [55,000 cSt]	°F [°C]	LBS [KG]	CU. FT.
GHC	GHS 2 JL9-B ●	77 [243]	1150 [960]	58 [133]	870 [725]	75 [5]	100 [7]	200 [14]	GHC ●	161 [73,2]	5.3
	GHS 2 JL10-B ■									161 [73,2]	
GHC 3 JL9-B ● †	GHS 3 JL9-B ●	107 [338]	960 [960]	81 [256]	580 [480]	75 [5]	100 [7]	200 [14]	GHC ●	161 [73,2]	5.3
	GHS 3 JL10-B ■									161 [73,2]	
GHC 3 JP9-B ● †	GHS 2 JP9-B ●	99 [375]	960 [960]	80 [252]	580 [480]	75 [5]	100 [7]	200 [14]	GHC ●	161 [73,2]	5.3
	GHS 2 JP10-B ■									161 [73,2]	
GHC 3 JP9-B ● †	GHS 3 JP9-B ●	132 [500]	960 [960]	80 [252]	580 [480]	75 [5]	100 [7]	200 [14]	GHC ●	161 [73,2]	5.3
	GHS 3 JP10-B ■									161 [73,2]	
GHC 3 NK9-B ● †	GHS 2 NK9-B ●	165 [624]	960 [960]	99 [312]	580 [480]	75 [5]	100 [7]	200 [14]	GHC ●	180 [81,8]	5.3
	GHS 2 NK10-B ■									180 [81,8]	
GHC 3 NK9-B ● †	GHS 2-1/2 NK9-B ●	172 [542]	960 [960]	115 [362]	580 [480]	75 [5]	100 [7]	200 [14]	GHC ●	180 [81,8]	5.3
	GHS 2-1/2 NK10-B ■									180 [81,8]	
GHC 3 NK9-B ● †	GHS 3 NK9-B ●	215 [678]	720 [600]	143 [451]	480 [400]	75 [5]	100 [7]	200 [14]	GHC ●	180 [81,8]	5.3
	GHS 3 NK10-B ■									180 [81,8]	
GHC 3 NM9-B ● †	GHS 2 NM9-B ●	172 [542]	720 [600]	143 [451]	480 [400]	75 [5]	100 [7]	200 [14]	GHC ●	180 [81,8]	5.3
	GHS 2 NM10-B ■									180 [81,8]	
GHC 3 NM9-B ● †	GHS 2-1/2 NM9-B ●	172 [542]	720 [600]	143 [451]	480 [400]	75 [5]	100 [7]	200 [14]	GHC ●	180 [81,8]	5.3
	GHS 2-1/2 NM10-B ■									180 [81,8]	
GHC 3 NP9-B ● †	GHS 3 NP9-B ●	172 [542]	720 [600]	143 [451]	480 [400]	75 [5]	100 [7]	200 [14]	GHC ●	180 [81,8]	5.3
	GHS 3 NP10-B ■									180 [81,8]	
GHC 3 NP9-B ● †	GHS 2-1/2 NP9-B ●	172 [542]	720 [600]	143 [451]	480 [400]	75 [5]	100 [7]	200 [14]	GHC ●	180 [81,8]	5.3
	GHS 2-1/2 NP10-B ■									180 [81,8]	
GHC 3 NP9-B ● †	GHS 2 RM9-B ●	172 [542]	720 [600]	143 [451]	480 [400]	75 [5]	100 [7]	200 [14]	GHC ●	357 [162]	10.7
	GHS 2 RM10-B ■									357 [162]	
GHC 3 RM9-B ● †	GHS 2-1/2 RM9-B ● †	172 [542]	720 [600]	143 [451]	480 [400]	75 [5]	100 [7]	200 [14]	GHC ●	357 [162]	10.7
	GHS 2-1/2 RM10-B ■ †									357 [162]	
GHC 3 RM9-B ● †	GHS 3 RM9-B ● †	172 [542]	720 [600]	143 [451]	480 [400]	75 [5]	100 [7]	200 [14]	GHC ●	357 [162]	10.7
	GHS 3 RM10-B ■ †									357 [162]	
GHC 3 RM9-B ● †	GHS 4 RM9-B ● †	172 [542]	720 [600]	143 [451]	480 [400]	75 [5]	100 [7]	200 [14]	GHC ●	357 [162]	10.7
	GHS 4 RM10-B ■ †									357 [162]	
GHC 3 RP9-B ● †	GHS 3 RP9-B ● †	172 [542]	720 [600]	143 [451]	480 [400]	75 [5]	100 [7]	200 [14]	GHC ●	357 [162]	10.7
	GHS 3 RP10-B ■ †									357 [162]	
GHC 3 RP9-B ● †	GHS 4 RP9-B ● †	172 [542]	720 [600]	143 [451]	480 [400]	75 [5]	100 [7]	200 [14]	GHC ●	357 [162]	10.7
	GHS 4 RP10-B ■ †									357 [162]	

STANDARD MODELS CONTINUED

- MECHANICAL SEAL
- PACKING/LIP SEAL

† PORTS ARE COMPATIBLE WITH 150# ANSI FLANGES. ALL OTHER PORTS ARE TAPPED NPT FOR ANSI PIPE. OPTIONAL [DIN] FLANGES OR TAPPED [BSP] PORTS ARE AVAILABLE FOR EXPORT MARKET.

NOTE: RECOMMENDED PORT SIZES ARE SHOWN IN **BOLDFACE**. EXAMPLE: **GHC 1 DC9-B, GHS 1 DC9-B**

THE GORMAN-RUPP COMPANY • MANSFIELD, OHIO
 GORMAN-RUPP OF CANADA LIMITED • ST. THOMAS, ONTARIO, CANADA

MODEL NUMBER		NOM. CAPACITY - SPEED				MAXIMUM				SHIPPING DATA	
		MAXIMUM		ALTERNATIVE		DIFF. PRESSURE - PSI [BAR]			TEMP.	Wt.	Vol.
		GPM [LPM]	RPM 60 Hz [50 HZ]	GPM [LPM]	RPM 60 Hz [50 HZ]	BELOW 38 SSU [4 cSt]	38 TO 100 SSU [21 cSt]	100 TO 250,000 SSU [55,000 cSt]	°F [°C]	LBS [KG]	CU. FT.
GHC	GHS										
	GHS 3 RR9-B ● ▸ GHS 3 RR10-B ■ ▸	255 [804]	720 [600]	170 [536]	480 [400]	75 [5]	100 [7]	200 [14]	GHS ● 400 [204] ■ 500 [260]	357 [162]	10.7
	GHS 4 RR9-B ● ▸ GHS 4 RR10-B ■ ▸			196 [618]						357 [162]	
	GHS 4 RS9-B ● ▸ GHS 4 RS10-B ■ ▸			295 [930]						357 [162]	

▸ PORTS ARE COMPATIBLE WITH 150# ANSI STAINLESS STEEL FLANGES. ALL OTHER PORTS ARE TAPPED NPT FOR ANSI PIPE. OPTIONAL [DIN] FLANGES OR TAPPED [BSP] PORTS AVAILABLE FOR EXPORT MARKET.

NOTE: RECOMMENDED PORT SIZES ARE SHOWN IN BOLDFACE. EXAMPLE: **GHC 1 DC9-B**, **GHS 1 DC9-B**

APPLICATION RECOMMENDATIONS:		
APPLICATION	OPTIONS REQUIRED (Select One From Each Row)	OPERATING LIMITATIONS
GHS ONLY HIGH TEMPERATURE	25U, 25V, OR 25W 35J – 35M (AS REQ'D) 40R, 70K 61H OR 65Q	TEMPERATURE: 675 °F MAX. PRESSURE: 200 PSI MAX.
GHS ONLY JACKETED	40K, 40W, 41U, 41W	LIMIT JACKET PRESSURE TO 150 PSI

NOTE: PROPER PUMP APPLICATION REQUIRES CONSIDERATION OF ADDITIONAL FACTORS. PLEASE REVIEW APPLICATION GUIDE IN SECTION 500 OR CONSULT THE FACTORY.

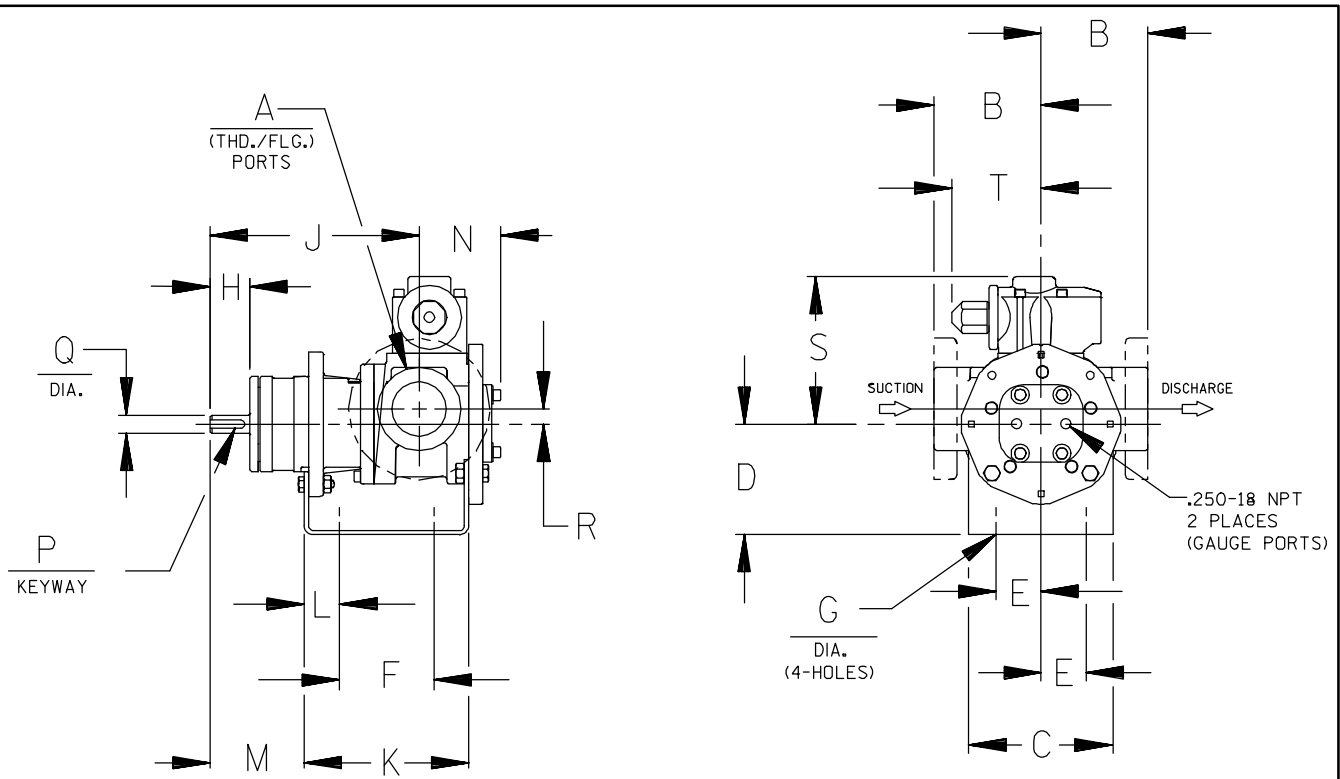

CAD FILE NO.: 16458B

MODEL NUMBERS	PUMP DIMENSIONS - INCHES [MILLIMETERS]																	
	A	B	C	D	E	F	G	H	J	K	L	M	N	P	Q	R	S	T
GHC D	1"	2.50 [64] †	4.00 [102]	3.50* [89]	1.62 [41]	3.12 [79]	.41 [10]	1.16 [30]	6.19 [157]	5.04 [128]	.76 [19]	2.62 [66]	2.74 [70]	.12 [3]	.50 [13]	.62 [16]	5.19 [132]	3.58 [91]
		4.00* [102] †		5.25 [133]										.75 [19]				
GHC G	1-1/2"	3.50 [89] †	5.88 [149]	3.50* [89]	1.62 [41]	4.00 [102]	.41 [10]	1.62 [41]	8.50 [216]	6.71 [170]	1.06 [27]	3.82 [97]	3.35 [85]	.19 [5]	.75 [19]	.62 [16]	6.00 [152]	3.62 [92]
		4.00* [102] †		4.50 [114]										5.25 [133]				
GHC J	3"	4.50 [114] †	6.88 [175]	4.50 [114]	2.88 [73]	4.25 [108]	.44 [11]	2.50 [64]	12.12 [308]	9.75 [248]	1.75 [44]	5.50 [140]	4.66 [118]	.25 [6]	1.00 [25]	1.12 [28]	9.06 [230]	6.75 [171]
		6.00* [152] †		5.25* [133]										6.25 [159]				

* STANDARD DIMENSION

† PORTS ARE COMPATIBLE WITH 125* OR 250* ANSI CAST IRON FLANGES. ALL OTHER PORTS ARE TAPPED NPT FOR ANSI PIPE. OPTIONAL (DIN) FLANGES OR TAPPED (BSP) PORTS AVAILABLE FOR EXPORT MARKET.

† 90° HOUSING

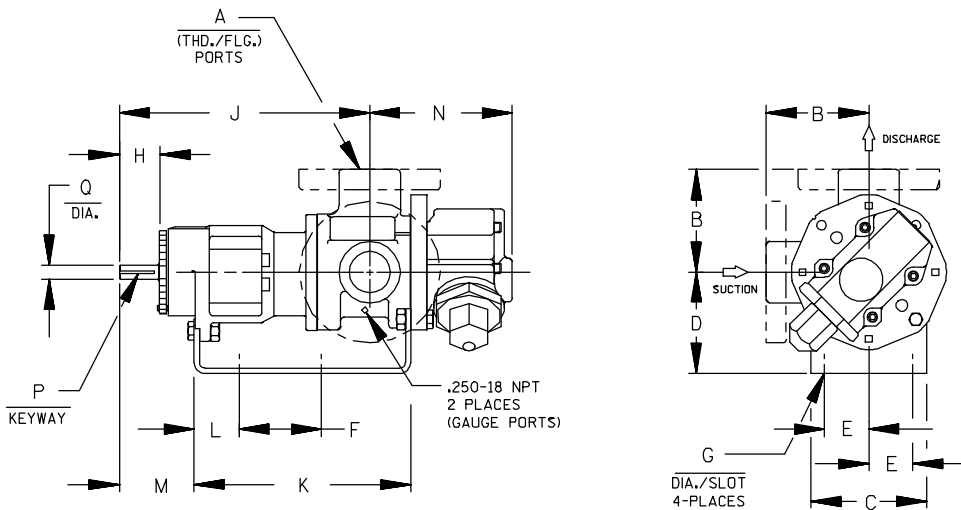

CAD FILE NO.: 16669G

MODEL NUMBERS	PUMP DIMENSIONS - INCHES [MILLIMETERS]														
	A	B	C	D	E	F	G	H	J	K	L	M	N	P	Q
GHS D	1"	2.50* [641]	4.00 [102]	3.50* [891]	1.62 [41]	5.50 [140]	.41 [10]	1.16 [30]	8.43 [214]	7.54 [192]	1.09 [28]	2.29 [58]	4.98 [127]	.12 [3] x .75 [19]	.50 [13]
		4.00 † [102]		5.25 [133]											
GHS G	1-1/2" 2"	3.50* [891]	4.88 [124]	3.50* [891]	1.62 [41]	8.00 [203]	.41 [10]	1.62 [41]	12.06 [306]	10.72 [272]	1.52 [39]	3.35 [85]	5.70 [145]	.19 [5] x 1.25 [32]	.75 [19]
		4.00 † [102]		5.25 [133]											
GHS J	2" 3"	4.50* [114]	6.88 [175]	5.25* [133]	2.88 [73]	10.00 [254]	.44 [11]	2.50 [64]	15.68 [398]	14.31 [363]	2.77 [70]	4.48 [114]	8.50 [216]	.25 [6] x 2.00 [51]	1.00 [25]
		6.00 † [152]		6.25 [159]											
GHS N	2" 3"	5.12 [130]	8.00 [203]	4.50 [114]	2.88 [73]	10.00 [254]	.44 [11]	2.58 [66]	16.37 [416]	15.14 [385]	2.69 [68]	4.56 [116]	8.72 [221]	.25 [6] x 2.00 [51]	1.12 [28]
				5.25* [133]											
GHS R	2"	6.50 [165]	10.50 [267]	7.00 [178]	3.75 [95]	13.75 [349]	.52 [13]	2.25 [57]	17.87 [454]	17.36 [441]	1.86 [47]	4.70 [119]	11.31 [287]	.38 [10] x 1.88 [48]	1.44 [37]
	2-1/2"														
	3"														
	4"	7.19 † [183]													

* STANDARD DIMENSION

† PORTS ARE COMPATIBLE WITH 150# OR 300# ANSISTAINLESS STEEL FLANGES. ALL OTHER PORTS ARE TAPPED NPT FOR ANSI PIPE. OPTIONAL (DIN) FLANGES OR TAPPED (BSP) PORTS AVAILABLE FOR EXPORT MARKET.

† 180° HOUSING

GHC/GHS

FOR GHC DRIVE OPTIONS

AND DIMENSIONS

SEE SECTION 540

FOR GHS DRIVE OPTIONS

AND DIMENSIONS

SEE SECTION 545



PERFORMANCE CURVES

SPEED VS. CAPACITY/HORSEPOWER

GH

Hydraulic Size

SEC. 500

Page 50

January 2010

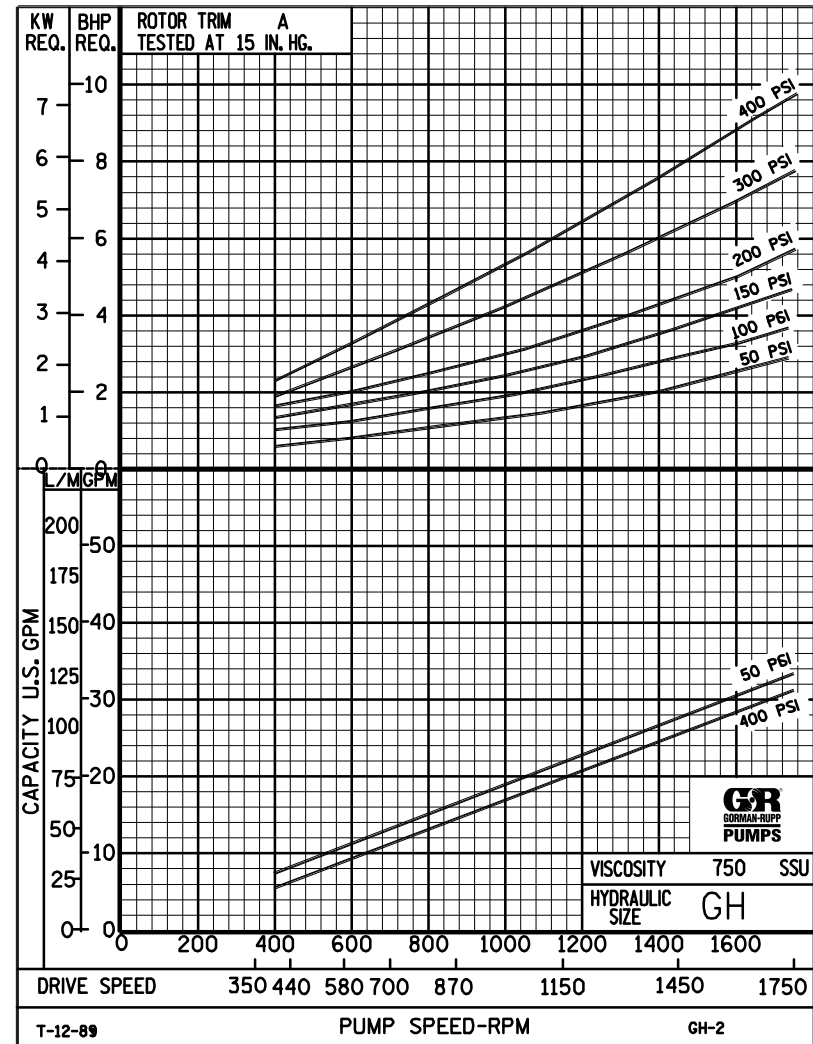
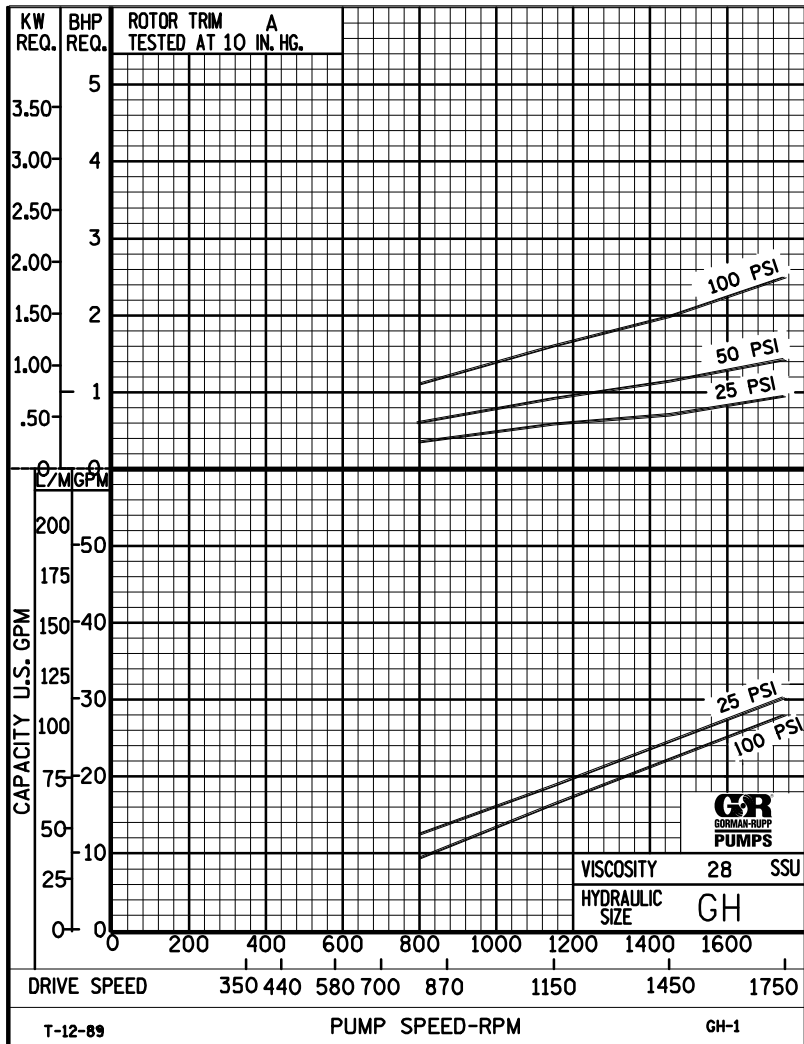

THE GORMAN-RUPP COMPANY • MANSFIELD, OHIO
 GORMAN-RUPP OF CANADA LIMITED • ST. THOMAS, ONTARIO, CANADA

Printed in U.S.A.



PERFORMANCE CURVES

SPEED VS. CAPACITY/HORSEPOWER

GH

Hydraulic Size

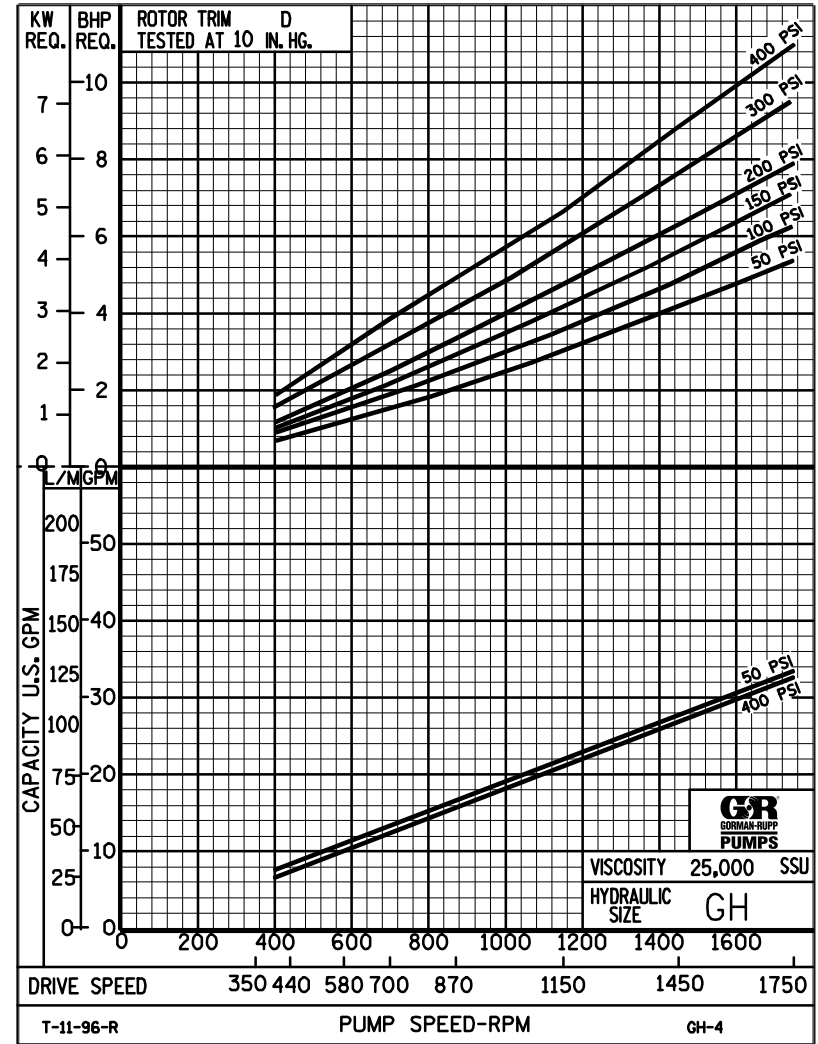
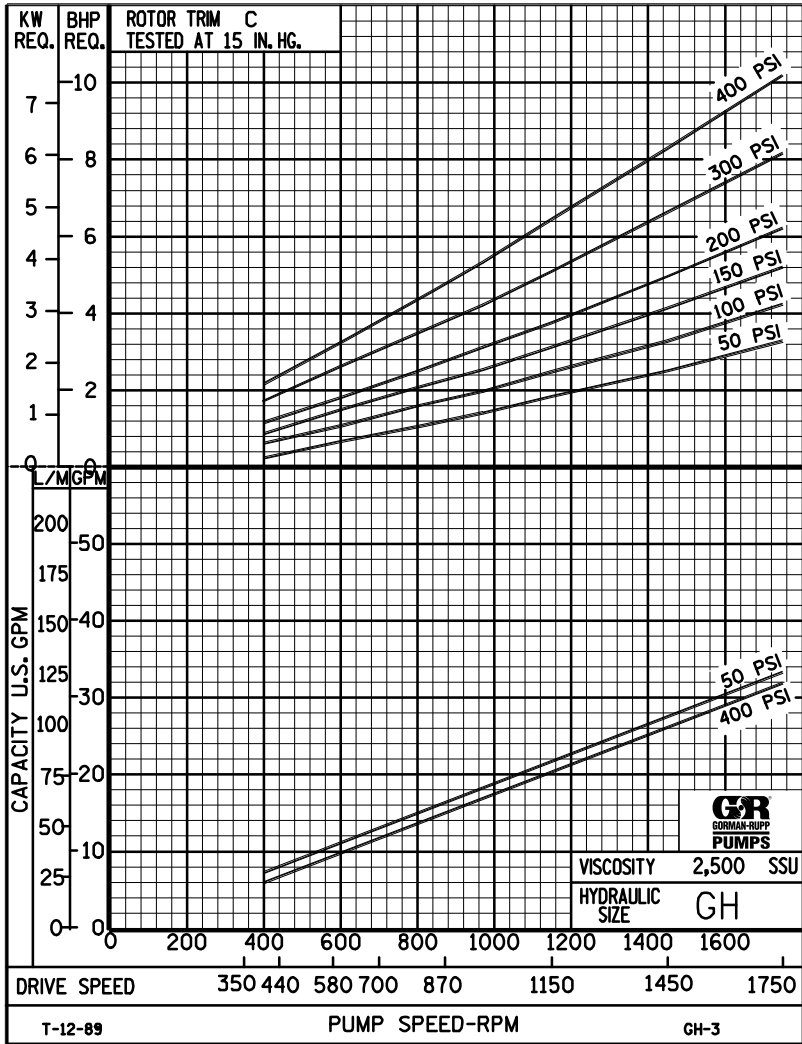

THE GORMAN-RUPP COMPANY • MANSFIELD, OHIO
 GORMAN-RUPP OF CANADA LIMITED • ST. THOMAS, ONTARIO, CANADA



GH

PUMP HYDRAULIC SIZE CHART

SEC. 500

Page 52
January 2010

**31 GPM
1750 RPM**

NOMINAL		ROTOR TRIM	VISCOSITY (SSU)	N.I.P.R. (PSIA)	FRICTION PIPE LOSS (PSI/FT) <small>(Based on Sch 40 Steel Pipe)</small>					FULL BYPASS RELIEF VALVE PRESSURE (PSI)					CAPACITY (GPM) / H.P. REQUIRED															
					PIPE DIAMETER					CRACKING PRESS. (PSI)					DIFFERENTIAL PRESSURE (PSI)															
CAP. GPM	SPEED RPM				3/4"	1"	1 1/4"	1 1/2"	2"	LOW PRES R/V					HI PRES R/V					MEDIUM DUTY AND HEAVY DUTY				HEAVY DUTY ONLY						
										50	75	100	150	200	50	75	100	150	200	25	50	75	100	150	200	300	400	25	50	75
31	1750	STD	28	4.2	.01	.01	.01	.01	.01	68	97	126				30	29	28	28											
			32		.61	.19	.05	.03	.01							.95	1.4	2.0	2.5											
			38	4.2	.78	.25	.07	.03	.01	68	97	126	176			31	30	29	29	28										
			50		.93	.30	.08	.04	.01							1.2	1.8	2.5	2.7	3.9										
			70	4.2	1.02	.35	.09	.05	.02	70	99	128	176	230		32	31	31	30	29	29									
			100		1.22	.39	.11	.05	.02							1.4	2.0	2.6	3.0	4.2	5.0									
			150	4.2	1.35	.44	.12	.06	.02	72	101	130	176	232		32	32	32	31	31	30	29	28							
			200		1.58	.52	.13	.07	.03							1.6	2.3	2.8	3.3	4.4	5.2	7.3	9.3							
			300	4.2	1.80	.61	.16	.08	.03	72	101	130	177	234		33	32	32	32	31	31	30	30							
			500		1.98	.75	.25	.14	.05							1.9	2.8	3.1	3.7	4.8	5.6	7.5	9.6							
		750	4.2	2.97	1.13	.38	.21	.08	74	102	132	177	235		33	33	33	33	32	32	31	30								
		1,000		3.96	1.51	.51	.27	.10							2.0	3.0	3.5	3.8	5.0	5.8	7.7	9.8								
		2,000	5.5	7.91	3.01	1.00	.54	.20	76	103	133	178	238		33	33	33	33	33	32	32	31								
		3,500		13.9	5.27	1.76	.95	.35							2.2	3.3	4.0	4.5	5.5	6.5	8.4	11								
		5,000	6.3	20.0	7.53	2.52	1.36	.50	80	105	137	180	240		33	33	33	33	33	32	32	31								
		7,500		29.7	11.3	3.77	2.04	.75							2.9	4.4	5.0	5.4	6.4	7.3	9.2	11.0								
		10,000	7.1	39.6	15.1	5.03	2.71	1.00	84	109	140	182	242		33	33	33	33	33	32	32	32								
		15,000		59.3	22.6	7.54	4.07	1.50							3.7	5.5	6.0	6.6	7.6	8.5	10	12								
		20,000	7.8	79.1	30.1	10.1	5.43	2.00	88	113	144	184	244		33	33	33	33	33	32	32	32								
		25,000		98.9	37.6	12.6	6.78	2.50							4.7	6.8	7.4	7.9	8.9	9.9	12	14								
50,000																														
75,000																														
100,000																														
150,000																														
200,000																														
250,000																														

(NOTE) For speeds not shown on the pump hydraulic charts, consult factory.



GH

PUMP HYDRAULIC SIZE CHART

SEC. 500

Page 53

January 2010

**20 GPM
1150 RPM**

NOMINAL		ROTOR TRIM	VISCOSITY (SSU)	N.I.P.R. (PSIA)	FRICTION PIPE LOSS (PSI/FT) <small>(Based on Sch 40 Steel Pipe)</small>					FULL BYPASS RELIEF VALVE PRESSURE (PSI)					CAPACITY (GPM) / H.P. REQUIRED										
CAP. GPM	SPEED RPM				PIPE DIAMETER					CRACKING PRESS. (PSI)					DIFFERENTIAL PRESSURE (PSI)										
					3/4"	1"	1 1/4"	1 1/2"	2"	LOW PRES R/V			HI PRES R/V		MEDIUM DUTY AND HEAVY DUTY				HEAVY DUTY ONLY						
							50	75	100	150	200	25	50	75	100	150	200	300	400						
20	1150	STD	28	2.3	.01	.01	.01	.01	.01	63	89	114				18	18	17	16						
			32		.28	.09	.03	.01	.01							.58	.91	1.3	1.6						
			38	2.3	.36	.12	.03	.02	.01	63	89	114	164			19	19	18	17	17					
			50		.44	.14	.04	.02	.01							.66	1.1	1.4	1.7	2.3					
			70	2.3	.49	.15	.04	.02	.01	64	90	116	166	228		20	20	19	18	18	17				
			100		.58	.19	.05	.02	.01							.83	1.2	1.6	1.9	2.6	2.9				
			150	2.3	.64	.21	.06	.03	.01	64	90	116	166	228		21	20	20	19	18	18	17	16		
			200		.68	.25	.08	.04	.02							.91	1.3	1.7	2.0	2.8	3.3	4.5	5.9		
			300	2.3	.78	.30	.10	.06	.02	65	91	120	167	230		21	21	21	20	20	19	19	18		
			500		1.28	.49	.16	.09	.03							1.0	1.5	1.8	2.1	2.9	3.5	4.9	6.0		
			750	2.3	1.92	.73	.24	.13	.05	65	91	120	167	230		22	21	21	21	21	21	20	20		
			1,000		2.55	.97	.33	.18	.07							1.2	1.7	2.2	2.4	3.0	3.6	4.9	6.2		
		2,000	3.1	5.10	1.94	.65	.35	.13	66	92	121	168	230		22	21	21	21	21	21	21	20			
		3,500		8.93	3.40	1.14	.61	.23							1.3	1.9	2.2	2.5	3.1	3.8	5.1	6.4			
		5,000	3.6	12.8	4.86	1.62	.88	.32	73	95	123	170	230		22	22	21	21	21	21	21	21			
		7,500		19.1	7.29	2.43	1.31	.49							1.7	2.5	2.7	3.0	3.7	4.4	5.6	6.9			
		10,000	4.1	25.5	9.71	3.24	1.75	.65	76	97	126	170	230		22	22	22	21	21	21	21	21			
		15,000		38.3	14.6	4.86	2.63	.97							2.6	3.0	3.4	3.7	4.4	5.1	6.3	7.6			
		20,000	4.6	51.0	19.4	6.49	3.50	1.29	79	101	128	172	230		22	22	22	21	21	21	21	21			
		25,000		63.8	24.3	8.11	4.38	1.61							3.5	3.7	4.1	4.4	5.1	5.7	7.0	8.3			
		50,000	7.3	128	48.6	16.2	8.75	3.22	84	107	132	178	235		22	22	22	21	21	21	21	21			
		75,000		191	72.8	24.3	13.1	4.83							5.4	5.7	6.3	6.8	7.4	8.2	9.6	11			
		100,000																							
		150,000																							
200,000																									
250,000																									

(NOTE) For speeds not shown on the pump hydraulic charts, consult factory.



GH

PUMP HYDRAULIC SIZE CHART

SEC. 500

Page 54

January 2010

**15 GPM
870 RPM**

NOMINAL		ROTOR TRIM	VISCOSITY (SSU)	N.I.P.R. (PSIA)	FRICTION PIPE LOSS (PSI/FT) <small>(Based on Sch 40 Steel Pipe)</small>					FULL BYPASS RELIEF VALVE PRESSURE (PSI)					CAPACITY (GPM) / H.P. REQUIRED										
					PIPE DIAMETER					CRACKING PRESS. (PSI)					DIFFERENTIAL PRESSURE (PSI)										
CAP. GPM	SPEED RPM				3/4"	1"	1 1/4"	1 1/2"	2"	LOW PRES R/V					MEDIUM DUTY AND HEAVY DUTY				HEAVY DUTY ONLY						
										50	75	100	150	200	25	50	75	100	150	200	300	400			
15	870	STD	28	1.6	.01	.01	.01	.01	.01	59	86	111			14	13	12	11							
			32		.17	.06	.02	.01	.01							.42	.68	.98	1.2						
			38	1.6	.22	.07	.02	.01	.01	59	86	111	161			14	14	13	12	12					
			50		.27	.09	.03	.01	.01							.48	.74	1.0	1.3	1.8					
			70	1.6	.30	.10	.03	.01	.01	60	87	113	163	215		15	14	14	13	13	13				
			100		.36	.12	.03	.02	.01							.67	.89	1.1	1.4	1.8	2.3				
			150	1.6	.41	.14	.05	.02	.01	60	87	113	163	217		16	15	15	14	14	14	13	12		
			200		.46	.18	.06	.03	.01							.74	.96	1.2	1.5	1.9	2.4	3.4	4.3		
			300	1.6	.58	.22	.08	.04	.02	60	87	115	165	219		16	16	15	15	15	15	14	13		
			500		.96	.37	.12	.07	.03							.82	1.0	1.3	1.5	2.0	2.5	3.5	4.5		
			750	1.6	1.44	.55	.18	.10	.04	60	87	115	165	222		16	16	16	16	16	15	15	14		
			1,000		1.92	.73	.25	.13	.05							.89	1.1	1.4	1.6	2.1	2.6	3.6	4.6		
		"C"	2,000	2.2	3.83	1.46	.49	.26	.10	62	90	115	165	222		16	16	16	16	16	16	15	15		
			3,500		6.70	2.55	.85	.46	.17							1.1	1.3	1.5	1.8	2.3	2.8	3.8	4.8		
			5,000	2.7	9.57	3.64	1.22	.66	.24	65	92	117	167	224		16	16	16	16	16	16	16	15		
			7,500		14.4	5.46	1.83	.99	.36							1.4	1.6	1.9	2.2	2.7	3.2	4.0	5.1		
			10,000	3.1	19.1	7.29	2.43	1.31	.49	68	94	119	169	224		16	16	16	16	16	16	16	16		
			15,000		28.7	10.9	3.65	1.97	.73							1.9	2.1	2.4	2.7	3.2	3.7	4.6	5.6		
			20,000	3.5	38.3	14.6	4.87	2.63	.97	72	97	122	172	224		16	16	16	16	16	16	16	16		
			25,000		47.8	18.2	6.08	3.28	1.21							2.4	2.6	2.9	3.1	3.7	4.2	5.1	6.1		
			50,000	5.8	95.7	36.4	12.2	6.56	2.42	77	102	127	177	229		16	16	16	16	16	16	16	16		
75,000			144	54.6	18.3	9.85	3.63							3.8	4.0	4.3	4.5	5.0	5.5	6.5	7.5				
"D"	100,000	8.4	191	72.8	24.3	13.1	4.83	85	110	135	185	239		16	16	16	16	16	16	16					
	150,000		-	-	-	-								4.6	4.8	5.1	5.4	5.8	6.4	7.3	8.3				
	200,000																								
	250,000																								

(NOTE) For speeds not shown on the pump hydraulic charts, consult factory.



PUMP HYDRAULIC SIZE CHART

SEC. 500

Page 55

January 2010

**10 GPM
580 RPM**

NOMINAL		ROTOR TRIM	VISCOSITY (SSU)	N.I.P.R. (PSIA)	FRICTION PIPE LOSS (PSI/FT) <small>(Based on Sch 40 Steel Pipe)</small>					FULL BYPASS RELIEF VALVE PRESSURE (PSI)					CAPACITY (GPM) / H.P. REQUIRED															
CAP. GPM	SPEED RPM				PIPE DIAMETER					CRACKING PRESS. (PSI)					DIFFERENTIAL PRESSURE (PSI)															
		3/4"	1"	1 1/4"	1 1/2"	2"	LOW PRES R/V					HI PRES R/V					MEDIUM DUTY AND HEAVY DUTY				HEAVY DUTY ONLY									
							50	75	100	150	200	50	75	100	150	200	25	50	75	100	150	200	300	400						
10	580	STD	28	1.2	.01	.01	.01	.01	.01	56	81	106								9	8.5	8	7.5							
			32		.08	.03	.01	.01	.01											.25	.41	.59	.73							
			38	1.2	.11	.04	.01	.01	.01	56	81	106	157								9.5	9	8.5	8	7.5					
			50		.13	.04	.01	.01	.01												.29	.45	.63	.80	1.1					
			70	1.2	.14	.05	.02	.01	.01	56	81	107	158	209							10	9.5	9.5	9	8.5	8.5				
			100		.14	.05	.02	.01	.01												.40	.54	.69	.84	1.1	1.4				
			150	1.2	.17	.07	.03	.02	.01	57	82	108	158	211							10	10	10	9.5	9.5	9	9	8		
			200		.30	.12	.04	.02	.01												.45	.58	.73	.88	1.2	1.4	2.0	2.6		
			300	1.2	.39	.15	.05	.02	.01	57	82	109	159	212							11	10	10	10	10	9.5	9.5	9		
			500		.64	.24	.08	.05	.02												.49	.62	.77	.92	1.2	1.5	2.1	2.7		
			750	1.2	.96	.36	.12	.07	.03	57	82	111	161	214							11	11	10	10	10	10	10	9.5		
			1,000		1.28	.49	.16	.09	.03												.54	.66	.82	.97	1.3	1.6	2.2	2.8		
		2,000	1.7	2.55	.97	.33	.18	.07	58	85	112	162	214							11	11	11	10	10	10	10	10			
		3,500		4.46	1.70	.57	.31	.12												.64	.76	.91	1.1	1.4	1.7	2.3	2.9			
		5,000	2.1	6.38	2.43	.81	.44	.16	60	85	112	162	214							11	11	11	11	10	10	10	10			
		7,500		9.57	3.64	1.22	.66	.24												.82	.97	1.1	1.3	1.6	1.9	2.4	3.0			
		10,000	2.5	12.8	4.86	1.62	.88	.32	63	88	114	166	216							11	11	11	11	10	10	10	10			
		15,000		19.2	7.29	2.43	1.31	.49												1.1	1.3	1.4	1.6	1.9	2.2	2.8	3.4			
		20,000	2.9	25.5	9.71	3.24	1.75	.65	66	91	116	168	218							11	11	11	11	10	10	10	10			
		25,000		31.9	12.2	4.05	2.19	.81												1.4	1.5	1.7	1.9	2.2	2.5	3.2	3.9			
		50,000	4.8	63.8	24.3	8.11	4.38	1.61	69	94	122	172	224							11	11	11	11	10	10	10	10			
		75,000		95.7	36.4	12.2	6.56	2.42												2.0	2.2	2.4	2.5	2.9	3.2	3.9	4.6			
100,000	7.1	128	48.6	16.2	8.75	3.22	73	98	126	176	230							11	11	11	11	10	10	10	10					
150,000		191	72.9	24.3	13.1	4.83												2.5	2.8	3.0	3.2	3.5	3.9	4.5	5.2					
200,000																														
250,000																														

(NOTE) For speeds not shown on the pump hydraulic charts, consult factory.



GH

SEC. 500

PAGE 55.1

February 2025

**4 GPM
200 RPM**

NOMINAL		VISCOSITY		N.I.P.R.	FRICTION PIPE LOSS (PSI/FT) <small>(Schedule 40 Steel Pipe)</small>					CAPACITY (GPM)				H.P. REQUIRED						
GPM	RPM	ROTOR TRIM	(SSU)	(PSIa)	PIPE DIAMETER					MEDIUM-DUTY & HEAVY-DUTY				HEAVY-DUTY ONLY						
					1½"	2"	2½"	3"	4"	25	50	75	100	150	200	300	400			
4	200	STD																		
				"D"																
					200,000	2.4	7	2.6	1.3	0.5	0.2	3.8	3.8	3.8	3.8	3.8	3.8	3.7	3.7	
					399,999		14	5.2	2.5	1.1	0.4	1.1	1.2	1.4	1.5	1.7	1.8	2.0	2.1	
					400,000	2.7						3.8	3.8	3.8	3.8	3.8	3.8	3.7	3.7	
					599,999		21	7.7	3.8	1.6	0.5	1.3	1.4	1.5	1.7	1.9	2.0	2.1	2.2	
					600,000	3.3						3.8	3.8	3.8	3.8	3.8	3.8	3.7	3.7	
					799,999		NR	10.3	5.1	2.1	0.7	1.4	1.5	1.6	1.8	2.0	2.1	2.2	2.3	
					800,000	3.6						3.8	3.8	3.8	3.8	3.8	3.8	3.7	3.7	
					1M		NR	12.9	6.3	2.7	0.9	1.6	1.9	1.9	1.9	2.1	2.2	2.3	2.4	

(NOTE) For speeds not shown on the pump hydraulic charts, consult factory.