

GHS SERIES Flexible Seal HEAVY DUTY STANDARD STEEL ROTARY GEAR PUMP

This heavy duty series pump is ideal for refining, petrochemical and applications requiring extra strength or shock resistance. The steel construction conforms to ASTM designation A216 Grade WCB. Superior rotor shaft support and an integral, maintenance-free radial/thrust bearing, reduce deflection and wear.

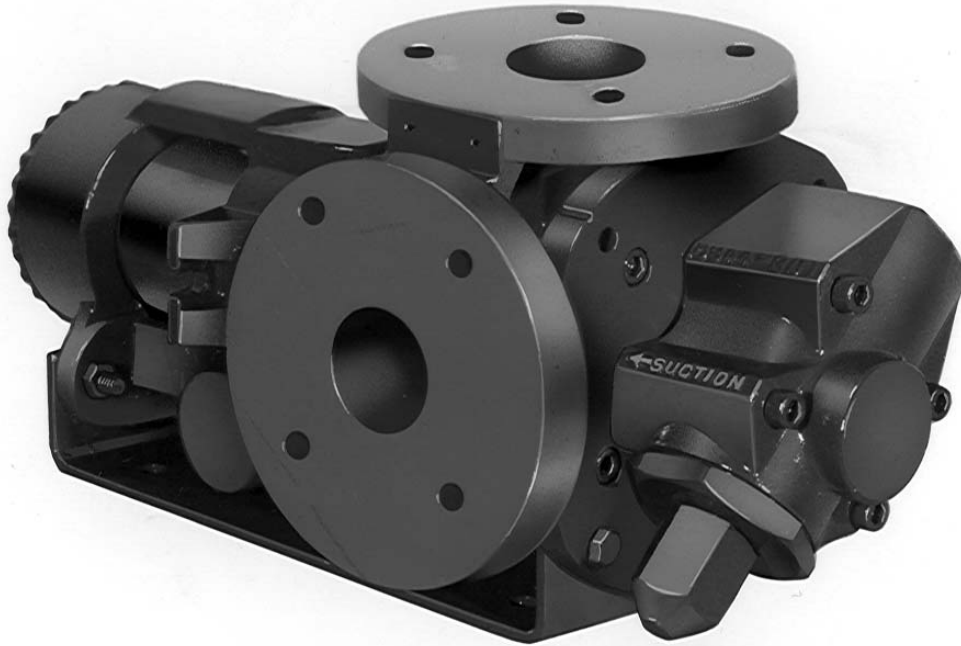

The GHS steel series is designed for applications in the operating ranges noted below. These units are available with head and backhead jackets for temperature control, carbon graphite bushings for low viscosity liquids, silicon carbide bushings for wear resistance, and numerous shaft seal options described on the following pages.

FEATURES

400 PSI CAPABILITY
BALL BEARING THRUST CONTROL
ROTOR END CLEARANCE EXTERNALLY ADJUSTABLE
HIGH STRENGTH, COMPUTER PROFILED GEARING FOR QUIET OPERATION
MULTIPLE PORT POSITIONS
FLEXIBLE SEAL DESIGN ALLOWS FOR A VARIETY OF INDUSTRIAL STANDARD SEALS OR PACKING
INTERNAL SEAL VENT

OPERATING RANGE

CAPACITY (GPM) : (3 TO 295)
 [LPM] : [11 TO 1116]

PRESSURE (PSI) : [0 TO 300]
 [BAR] : [0 TO 21]

VISCOSITY (SSU) : (28 TO 2,000,000)
 [cSt] : [1 TO 440,000]

TEMPERATURE (F) : (-20° TO 675°)
 [C] : [-29° TO 358°]

APPLICATIONS

USE WITH ANY CLEAN LIQUID COMPATIBLE WITH IRON/STEEL

- ★ BOOSTER SERVICE
- ★ CIRCULATING
- ★ FILTERING
- ★ LUBRICATING
- ★ TRANSFERRING

EXTERIOR	BACKHD	ROTOR & IDLER	HOUSING PORTS	BUSHING	IDLER PIN	SHAFT	SHAFT SEALING		ROTA-TION	INTERNAL RELIEF VALVE	
							MECH. SEAL ●	PACKING ■		MATERIAL	SETTING
STEEL ③	DUCTILE IRON	HIGH STRENGTH IRON	150# FLG GHC 180° GHS 90°	BRONZE	HARD STEEL	STEEL	VITON	CARBON FIBER	C.W.	STEEL	75 PSI [5 BAR]

Standard Models

G H C 3 JG 32 - B
G H S 3 JG 32 - B
 | | | | | | | | | | | |
 GEAR DUTY DESIGN PORT SIZE HYDRAULIC SEAL STYLE

MODEL NUMBER		NOM. CAPACITY - SPEED				MAXIMUM				SHIPPING DATA		
		MAXIMUM		ALTERNATIVE		DIFF. PRESSURE - PSI [BAR]			TEMP	Wt.	Vol.	
		GPM [LPM]	RPM 60 Hz [50 HZ]	GPM [LPM]	RPM 60 Hz [50 HZ]	BELOW 38 SSU [4 cSt]	38 TO 100 SSU [21 cSt]	100 TO 250,000 SSU [55,000 cSt]	°F [°C]			
GHC	GHS							LBS [KG]	CU. FT.			
GHC 1 DC32-B ① ● †		9 [28]		6 [19]						39 [17,7]	0.6	
GHC 1 DE32-B ① ● †		11 [35]		7 [22]						39 [17,7]	0.6	
GHC 1-1/2 GC32-B ● †	GHS 1-1/2 GC32-B ● † GHS 1-1/2 GC38-B ■ †	16 [50]	1750 [1460]	10 [32]	1150 [960]			300 [21]	GHC ●	71 [32,2]	2.9	
GHC 1-1/2 GF32-B ● †	GHS 1-1/2 GF32-B ● † GHS 1-1/2 GF38-B ■ †	23 [73]		15 [47]						350 [177]	71 [32,2]	2.9
GHC 1-1/2 GH32-B ● †	GHS 1-1/2 GH32-B ● † GHS 1-1/2 GH38-B ■ †	31 [98]		20 [63]						GHS ●	71 [32,2]	2.9
GHC 1-1/2 GJ32-B ② ● †	GHS 1-1/2 GJ32-B ② ● † GHS 1-1/2 GJ38-B ② ■ †	38 [120]		25 [79]				100 [7]	150 [10]	400 [204]	71 [32,2]	2.9
GHC 3 JG32-B ● †	GHS 3 JG32-B ● † GHS 3 JG38-B ■ †	40 [126]	1150 [960]	30 [95]	870 [725]				500 [260]	154 [69,8]	5.3	
GHC 3 JJ32-B ● †	GHS 3 JJ32-B ● † GHS 3 JJ38-B ■ †	56 [177]		36 [114]						300 [21]	154 [69,8]	5.3
GHC 3 JL32-B ● †	GHS 3 JL32-B ● † GHS 3 JL38-B ■ †	77 [243]		58 [183]							154 [69,8]	5.3
GHC 3 JP32-B ② ● †	GHS 3 JP32-B ② ● † GHS 3 JP38-B ② ■ †	107 [338]		81 [256]						200 [14]	154 [69,8]	5.3

STANDARD MODELS CONTINUED

NOTE: RECOMMENDED PORT SIZES ARE SHOWN IN **BOLDFACE**. EXAMPLE: **GHC 3 JG32-B, GHS 3 JG32-B**

- MECHANICAL SEAL
- LIPSEAL/PACKING
- † PORTS ARE COMPATIBLE WITH 150# ANSI FLANGES. ALL OTHER PORTS ARE TAPPED NPT FOR ANSI PIPE. OPTIONAL [DIN] FLANGES OR TAPPED [BSP] PORTS AVAILABLE FOR EXPORT MARKET.

- ① 3450 [2875] RPM PERMISSIBLE TO 1,000 SSU [220 cSt] AND 100 PSI [7 BAR]
- ② PUMP LIMITED TO 200 PSI MAXIMUM PRESSURE.
- ③ REFER TO REFERENCE SECTION FOR SPECIFIC CONSTRUCTION DETAILS.

THE GORMAN-RUPP COMPANY • MANSFIELD, OHIO
GORMAN-RUPP OF CANADA LIMITED • ST. THOMAS, ONTARIO, CANADA

MODEL NUMBER		NOM. CAPACITY - SPEED				MAXIMUM				SHIPPING DATA	
		MAXIMUM		ALTERNATIVE		DIFF. PRESSURE - PSI [BAR]			TEMP.	Wt. LBS [KG]	Vol. CU. FT.
		GPM [LPM]	RPM 60 Hz [50 HZ]	GPM [LPM]	RPM 60 Hz [50 HZ]	BELOW 38 SSU [4 cSt]	38 TO 100 SSU [21 cSt]	100 TO 250,000 SSU [55,000 cSt]	°F [°C]		
GHC	GHS										
	GHS 2 NK32-B ● † GHS 2 NK38-B ■ †	99 [375]	960 [960]	60 [189]	580 [480]			300 [21]		200 [90,7]	5.3
	GHS 3 NK32-B ● † GHS 3 NK38-B ■ †									200 [90,7]	
	GHS 2 NM32-B ● † GHS 2 NM38-B ■ †	132 [500]	960 [960]	80 [252]	580 [480]			300 [21]		200 [90,7]	5.3
	GHS 3 NM32-B ● † GHS 3 NM38-B ■ †									200 [90,7]	
	GHS 3 NP32-B ① ● † GHS 3 NP38-B ① ■ †	165 [624]	960 [960]	99 [312]	580 [480]			200 [14]		200 [90,7]	5.3
	GHS 2-1/2 RM32-B ● † GHS 2-1/2 RM38-B ■ †	172 [542]								720 [600]	
	GHS 3 RM32-B ● † GHS 3 RM38-B ■ †		302 [136,9]								
	GHS 4 RM32-B ● † GHS 4 RM38-B ■ †		302 [136,9]								
	GHS 2-1/2 RP32-B ● † GHS 2-1/2 RP38-B ■ †		302 [136,9]								
	GHS 3 RP32-B ● † GHS 3 RP38-B ■ †	215 [678]	720 [600]	143 [451]	480 [400]	100 [7]	150 [10]	300 [21]	GHS ● 400 [204] ■ 500 [260]	302 [136,9]	10.7
	GHS 4 RP32-B ● † GHS 4 RP38-B ■ †									302 [136,9]	
	GHS 3 RR32-B ● † GHS 3 RR38-B ■ †	255 [804]	720 [600]	170 [536]	480 [400]	100 [7]	150 [10]	300 [21]	GHS ● 400 [204] ■ 500 [260]	302 [136,9]	10.7
	GHS 4 RR32-B ● † GHS 4 RR38-B ■ †									302 [136,9]	
	GHS 3 RS32-B ① ● † GHS 3 RS38-B ① ■ †	295 [930]	720 [600]	196 [618]	480 [400]	100 [7]	150 [10]	200 [14]	GHS ● 400 [204] ■ 500 [260]	302 [136,9]	10.7
	GHS 4 RS32-B ① ● † GHS 4 RS38-B ① ■ †									302 [136,9]	

STANDARD MODELS CONTINUED

- MECHANICAL SEAL
- LIPSEAL/PACKING
- † PORTS ARE COMPATIBLE WITH 150# ANSI FLANGES. ALL OTHER PORTS ARE TAPPED NPT FOR ANSI PIPE. OPTIONAL [DIN] FLANGES OR TAPPED [BSP] PORTS AVAILABLE FOR EXPORT MARKET.

① PUMP LIMITED TO 200 PSI MAXIMUM PRESSURE.

THE GORMAN-RUPP COMPANY • MANSFIELD, OHIO
 GORMAN-RUPP OF CANADA LIMITED • ST. THOMAS, ONTARIO, CANADA

APPLICATION RECOMMENDATIONS:		
APPLICATION	OPTIONS REQUIRED (Select One From Each Row)	OPERATING LIMITATIONS
GHS ONLY HIGH TEMPERATURE	25U, 25V, OR 25W 35J – 35M (AS REQ'D) 40M, 40W 61H, OR 65Q 70K	TEMPERATURE: 675° F MAX. PRESSURE: 200 PSI MAX.
ASPHALT	35J–35M (AS REQ'D) 40M, 40W, 40G 41R, 41W 65S 70, 70K, 71K	TEMPERATURE: 500° MAX.
JACKETED	40G, 40J, 40K, 40W, 41U, 41W	LIMIT JACKET PRESSURE TO 150 PSIG

NOTE: PROPER PUMP APPLICATION REQUIRES CONSIDERATION OF ADDITIONAL FACTORS. PLEASE REVIEW APPLICATION GUIDE IN SECTION 500 OR CONSULT THE FACTORY.

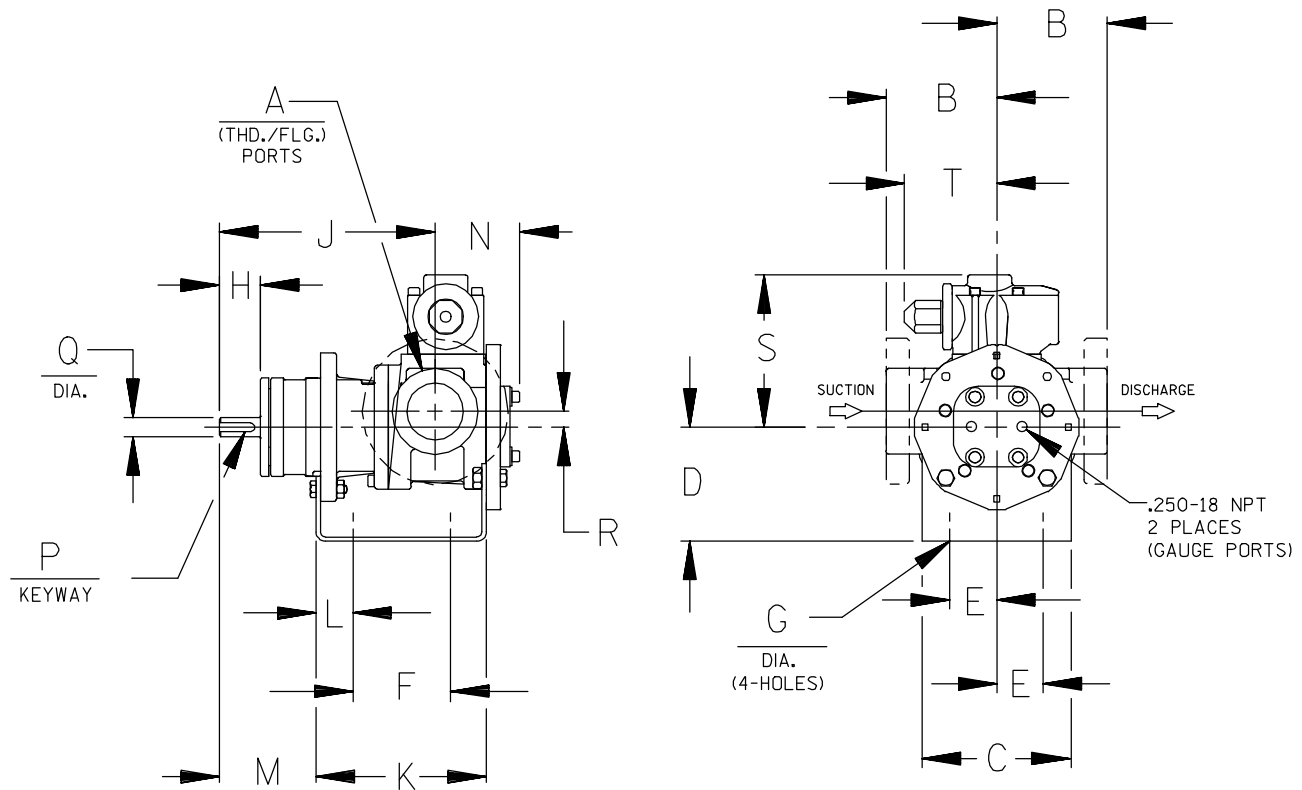

CAD FILE NO.: 16458D

MODEL NUMBERS	PUMP DIMENSIONS - INCHES [MILLIMETERS]																	
	A	B	C	D	E	F	G	H	J	K	L	M	N	P	Q	R	S	T
GHC D	1"	4.00 † [102]	4.00 [102]	3.50* [89] 4.50 [114] 5.25 [133]	1.62 [41]	3.12 [79]	.41 [10]	1.16 [30]	6.19 [157]	5.04 [128]	.76 [19]	2.62 [66]	2.74 [70]	.12 [3] x .75 [19]	.50 [13]	.62 [16]	5.19 [132]	3.58 [91]
GHC G	1-1/2"	4.00 † [102]	5.88 [149]	3.50* [89] 4.50 [114] 5.25 [133] 6.25 [159]	1.62 [41]	4.00 [102]	.41 [10]	1.62 [41]	8.50 [216]	6.71 [170]	1.06 [27]	3.82 [97]	3.35 [85]	.19 [5] x 1.25 [32]	.75 [19]	.62 [16]	6.00 [152]	3.62 [92]
GHC J	3"	6.00* [152] † 6.31 † [160]	6.88 [175]	4.50 [114] 5.25* [133] 6.25 [159] 7.00 [178] 8.00 [203]	2.88 [73]	4.25 [108]	.44 [11]	2.50 [64]	12.12 [308]	9.75 [248]	1.75 [44]	5.50 [140]	4.66 [118]	.25 [6] x 2.00 [51]	1.00 [25]	1.12 [28]	9.06 [230]	6.75 [171]

* STANDARD DIMENSION
 PORTS ARE COMPATIBLE WITH 150# OR 300# ANSISTEEL FLANGES. ALL OTHER PORTS ARE TAPPED NPT
 † FOR ANSIPipe. OPTIONAL [DIN FLANGES OR TAPPED [BSP] PORTS AVAILABLE FOR EXPORT MARKET.
 NPT FOR ANSIPipe. OPTIONAL (DIN) FLANGES OR TAPPED (BSP) PORTS AVAILABLE FOR EXPORT MARKET.
 ‡ 90° HOUSING

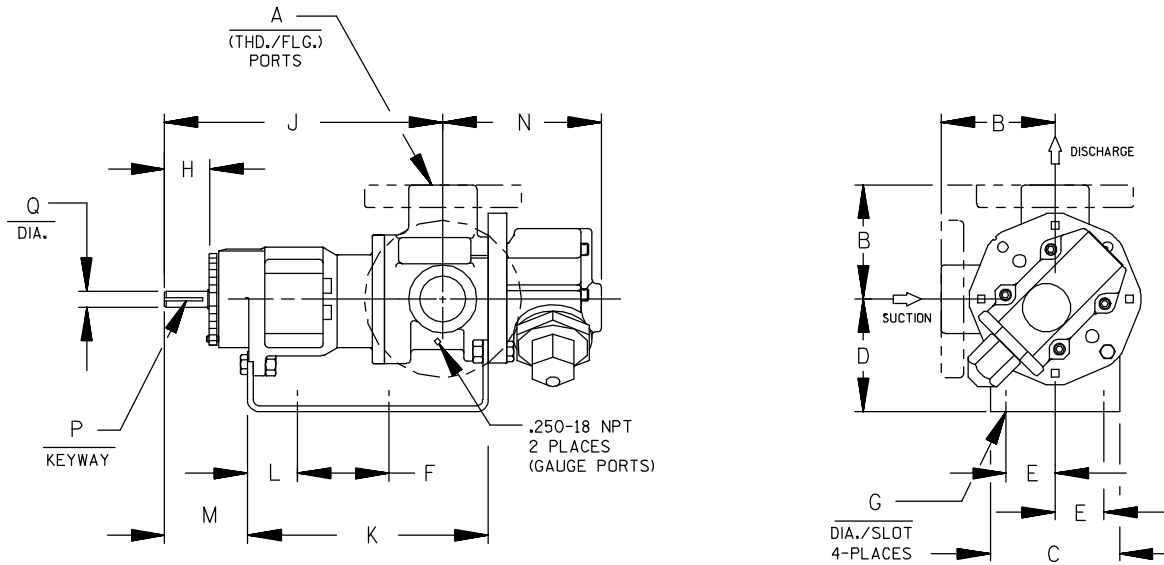

CAD FILE NO.: 16669F

MODEL NUMBERS	PUMP DIMENSIONS - INCHES [MILLIMETERS]														
	A	B	C	D	E	F	G	H	J	K	L	M	N	P	Q
GHS G	1-1/2"	4.00 [102]	4.88 [124]	3.50* [89] 4.50 [114] 5.25 [133] 6.25 [159]	1.62 [41]	8.00 [203]	.41 [10]	1.62 [41]	12.06 [306]	10.72 [272]	1.52 [39]	3.35 [85]	5.70 [145]	.19 [5] x 1.25 [32]	.75 [19]
GHS J	3"	6.00 † [152] 6.31 [160]	6.88 [175]	5.25* [133] 6.25 [159] 7.00 [178] 8.00 [203]	2.88 [73]	10.00 [254]	.44 [11]	2.50 [64]	15.68 [398]	14.31 [363]	2.77 [70]	4.48 [114]	8.50 [216]	.25 [6] x 2.00 [51]	1.00 [25]
GHS N	2"	5.25* [133] 5.38 [137]	8.00 [203]	4.50 [114] 5.25* [133] 6.25 [159] 7.00 [178] 8.00 [203]	2.88 [73]	10.00 [254]	.44 [11]	2.58 [66]	16.37 [416]	15.14 [385]	2.69 [68]	4.56 [116]	7.59 [193]	.25 [6] x 2.00 [51]	1.12 [32]
	3"	7.19 [183]											8.72 [221] *		
GHS R	2-1/2"													.38 [10] x 1.88 [48]	1.44 [37]
	3"	7.19 [183]	10.50 [267]	7.00 [178]	3.75 [95]	13.75 [349]	.52 [13]	2.25 [57]	17.87 [454]	17.36 [441]	1.80 [46]	4.70 [119]	11.31 [287]		
	4"														

* STANDARD DIMENSION

† PORTS ARE COMPATIBLE WITH 150* OR 300* ANSISTEEL FLANGES. ALL OTHER PORTS ARE TAPPED NPT FOR ANSIPIPE. OPTIONAL (DIN) FLANGES OR TAPPED (BSP) PORTS AVAILABLE FOR EXPORT MARKET.

† 180° HOUSING

GHC/GHS

FOR GHC DRIVE OPTIONS

AND DIMENSIONS

SEE

SECTION 540

FOR GHS DRIVE OPTIONS

AND DIMENSIONS

SEE

SECTION 545



PERFORMANCE CURVES

SPEED VS. CAPACITY/HORSEPOWER

RS Hydraulic Size

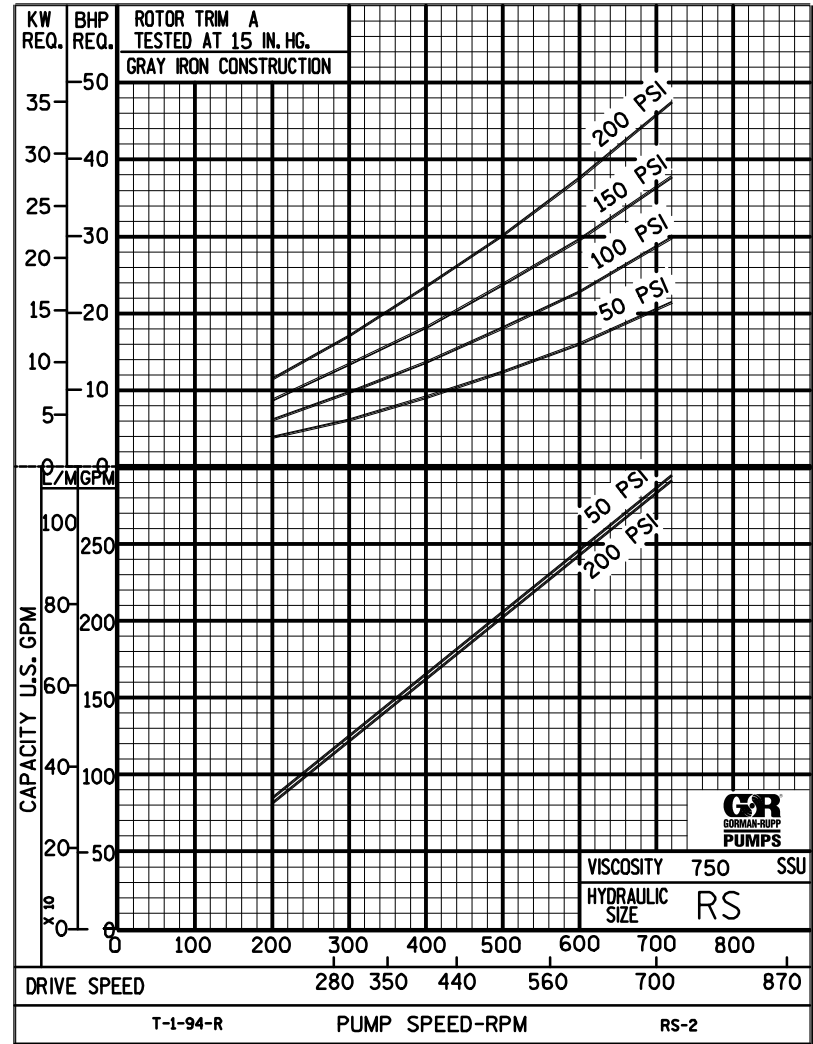
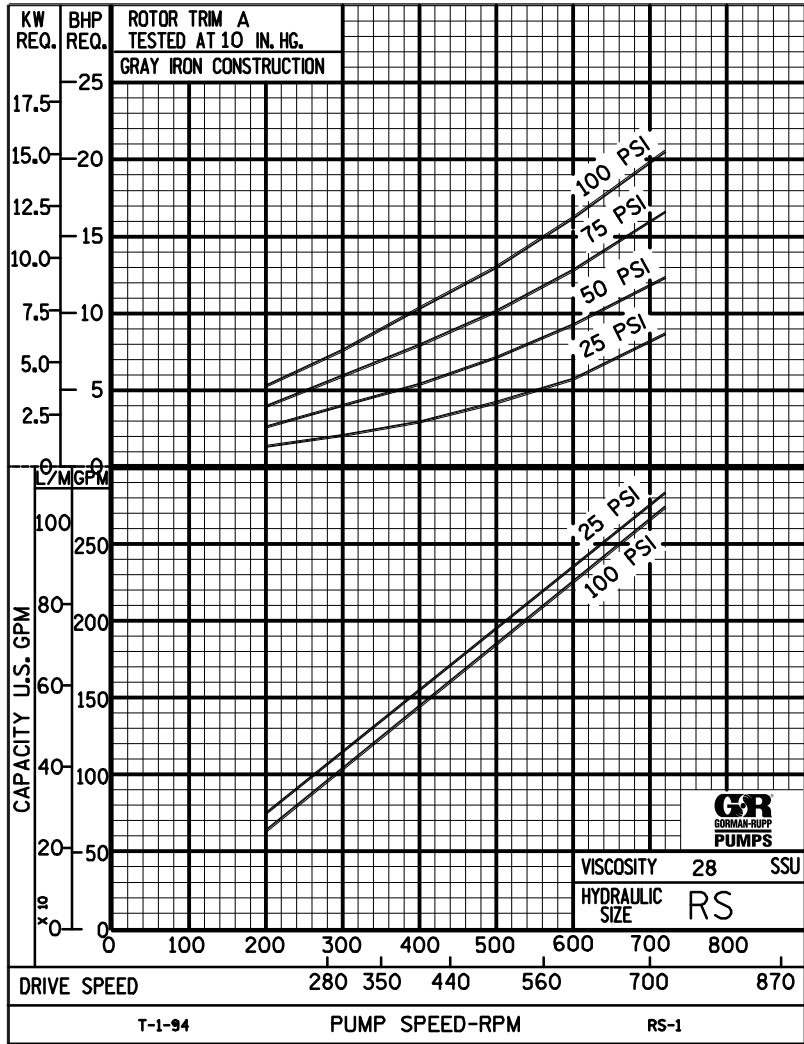

THE GORMAN-RUPP COMPANY • MANSFIELD, OHIO
 GORMAN-RUPP OF CANADA LIMITED • ST. THOMAS, ONTARIO, CANADA

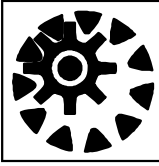

PERFORMANCE CURVES

SPEED VS. CAPACITY/HORSEPOWER

RS Hydraulic Size

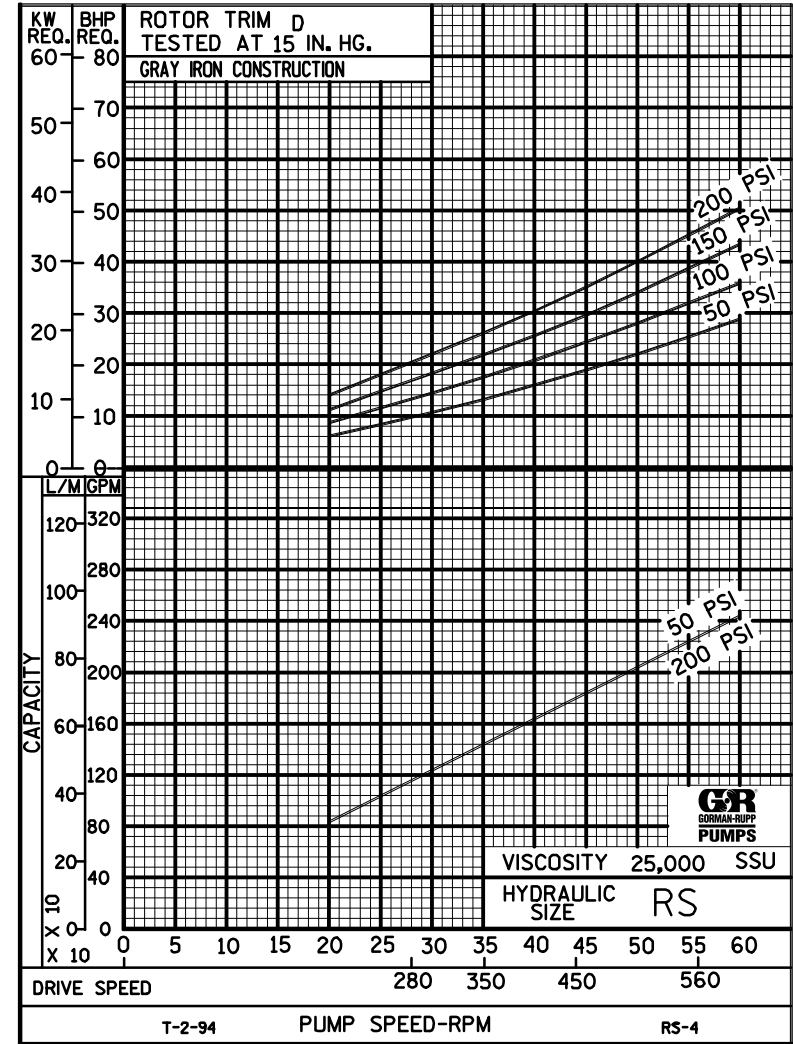
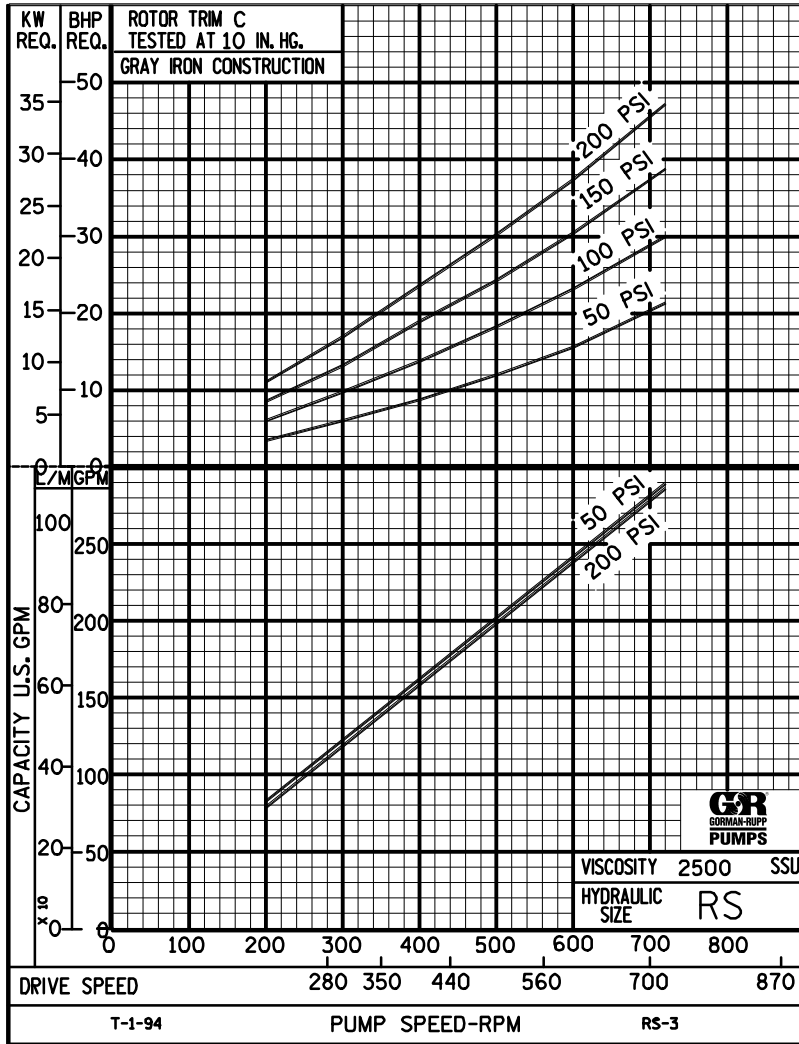

THE GORMAN-RUPP COMPANY • MANSFIELD, OHIO
 GORMAN-RUPP OF CANADA LIMITED • ST. THOMAS, ONTARIO, CANADA



RS

PUMP HYDRAULIC SIZE CHART

SEC. 500

Page 124

January 2010

295 GPM
720 RPM

NOMINAL		ROTOR TRIM	VISCOSITY (SSU)	N.I.P.R. (PSIA)	FRICTION PIPE LOSS (PSI/FT) <small>(Based on Sch 40 Steel Pipe)</small>					FULL BYPASS RELIEF VALVE PRESSURE (PSI)					CAPACITY (GPM) / H.P. REQUIRED																					
CAP. GPM	SPEED RPM				PIPE DIAMETER					CRACKING PRESS. (PSI)					DIFFERENTIAL PRESSURE (PSI)																					
		2"	2 1/2"	3"	4"	6"	LOW PRES R/V		HI PRES R/V			HEAVY DUTY																								
				50	75	100	150	200	25	50	75	100	150	200	300	400																				
295	720	STD	28	6.3	.61	.24	.08	.02	-	70	90	129	199								284	280	276	274												
			32		.64	.26	.09	.02	-												9.5	13	17	22												
			38	6.3	.67	.27	.09	.02	-	73	95	132	202									286	284	280	276	272										
			50		.71	.30	.10	.03	-													12	16	20	24	31										
			70	6.3	.78	.33	.11	.03	-	79	101	138	207	264									288	286	284	282	278	274								
			100		.85	.36	.13	.03	-														14	18	22	27	33	44								
			150	6.3	.93	.39	.14	.04	.01	85	107	144	211	276										292	290	288	286	284	282							
			200		1.00	.42	.15	.04	.01															16	20	24	28	35	45							
			300	6.3	1.10	.47	.17	.05	.01	92	116	152	218	292										294	292	292	290	290	286							
			500		1.27	.55	.20	.06	.01															17	21	25	30	37	47							
		750	6.3	1.44	.63	.15	.05	.01	98	122	158	222	304										296	294	294	294	294	292								
		1,000		1.59	.47	.20	.07	.01															17	22	26	30	38	47								
		2,000	6.7	1.90	.93	.39	.13	.03	108	134	169	230	326										290	290	288	288	288	286								
		3,500		3.33	1.63	.69	.23	.04															18	22	26	31	40	48								
		5,000	7.1	4.75	2.34	.98	.33	.06	114	140	176	235	339										290	290	290	288	288	286								
		7,500		7.13	3.50	1.47	.50	.10															20	23	28	32	41	49								
		10,000	7.6	9.51	4.67	1.96	.66	.13	120	147	182	240	352										290	290	290	290	288	288								
		15,000		14.3	7.01	2.94	.99	.19															24	27	30	34	43	52								
		20,000																																		
		25,000																																		
50,000																																				
75,000																																				
100,000																																				
150,000																																				
200,000																																				
250,000																																				

(NOTE) For speeds not shown on the pump hydraulic charts, consult factory.



RS

PUMP HYDRAULIC SIZE CHART

SEC. 500

Page 125

January 2010

**265 GPM
640 RPM**

NOMINAL		ROTOR TRIM	VISCOSITY (SSU)	N.I.P.R. (PSIA)	FRICTION PIPE LOSS (PSI/FT) <small>(Based on Sch 40 Steel Pipe)</small>					FULL BYPASS RELIEF VALVE PRESSURE (PSI)					CAPACITY (GPM) / H.P. REQUIRED														
CAP. GPM	SPEED RPM				PIPE DIAMETER					CRACKING PRESS. (PSI)					DIFFERENTIAL PRESSURE (PSI)														
					2"	2 1/2"	3"	4"	6"	LOW PRES R/V		HI PRES R/V			MEDIUM DUTY AND HEAVY DUTY				HEAVY DUTY ONLY										
265	640	STD	28	4.8	.48	.19	.06	.02	-	67	89	127	193		252	248	244	240											
			32		.50	.20	.07	.02	-						7.5	11	15	18											
			38	4.8	.52	.21	.07	.02	-	71	93	130	196		254	250	246	244	238										
			50		.56	.23	.08	.02	-						9.4	13	17	20	28										
			70	4.8	.62	.26	.09	.02	-	76	98	135	201	259		256	254	252	250	246	240								
			100		.68	.29	.10	.03	-							11	15	19	22	29	38								
			150	4.8	.74	.32	.11	.03	-	81	104	141	205	269		260	258	256	254	252	248								
			200		.80	.34	.12	.03	-							12	16	20	23	31	39								
			300	4.8	.89	.38	.14	.04	.01	88	112	148	211	282		262	260	258	258	256	254								
			500		1.03	.44	.16	.03	.01							13	17	21	25	32	41								
		750	5.0	1.17	.51	.13	.04	.01	92	118	153	216	292		264	262	262	260	260	258									
		1,000		.84	.41	.17	.06	.01							14	18	22	25	32	41									
		2,000	5.5	1.68	.82	.35	.12	.02	102	128	162	224	310		258	258	258	256	256	254									
		3,500		2.93	1.44	.60	.20	.04							15	18	22	26	34	41									
		5,000	6.0	4.19	2.06	.86	.29	.06	107	134	168	229	321		258	258	258	256	256	256									
		7,500		6.29	3.09	1.29	.44	.08							18	20	24	28	36	43									
		10,000	6.7	8.38	4.12	1.73	.58	.11	112	140	173	234	331		258	258	258	258	256	256									
		15,000		12.6	6.17	2.59	.87	.17							20	23	27	30	38	45									
		20,000	7.8	16.8	8.23	3.45	1.16	.23	116	144	181	237	339		260	260	260	258	258	256									
		25,000		21.0	10.3	4.32	1.46	.28							23	26	29	32	40	48									
50,000																													
75,000																													
100,000																													
150,000																													
200,000																													
250,000																													

(NOTE) For speeds not shown on the pump hydraulic charts, consult factory.

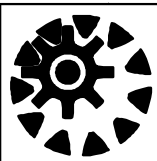

RS

PUMP HYDRAULIC SIZE CHART

SEC. 500

Page 126
January 2010

212 GPM
520 RPM

NOMINAL		ROTOR TRIM	VISCOSITY (SSU)	N.I.P.R. (PSIA)	FRICTION PIPE LOSS (PSI/FT) <small>(Based on Sch 40 Steel Pipe)</small>					FULL BYPASS RELIEF VALVE PRESSURE (PSI)					CAPACITY (GPM) / H.P. REQUIRED									
CAP. GPM	SPEED RPM				PIPE DIAMETER					CRACKING PRESS. (PSI)					DIFFERENTIAL PRESSURE (PSI)									
					2"	2 1/2"	3"	4"	6"	LOW PRES R/V			HI PRES R/V		MEDIUM DUTY AND HEAVY DUTY				HEAVY DUTY ONLY					
212	520	STD	28	3.2	.31	.13	.04	.01	-	62	87	123	185		204	200	196	192						
			32		.33	.13	.04	.01	-						4.9	7.9	11	14						
			38	3.2	.35	.14	.05	.01	-	64	90	126	187		206	202	198	196	190					
			50		.38	.16	.05	.01	-						6.3	9.1	12	16	21					
			70	3.2	.42	.18	.06	.02	-	69	95	130	192	251	208	206	202	200	196	192				
			100		.46	.20	.07	.02	-						7.9	10	14	17	23	30				
			150	3.2	.51	.22	.08	.02	-	74	99	134	196	258	212	208	206	206	204	200				
			200		.55	.24	.08	.02	-						8.9	12	15	18	24	31				
			300	3.2	.61	.27	.10	.03	-	80	105	140	202	267	212	212	210	208	208	206				
			500		.72	.31	.11	.02	-						9.6	13	16	19	25	32				
		750	3.3	.51	.25	.10	.04	.01	84	110	144	206	274	214	214	212	212	210	210					
		1,000		.68	.33	.14	.05	.01						10	13	16	19	25	32					
		2,000	4.1	1.35	.66	.28	.09	.02	92	118	151	213	287	212	212	210	210	208	206					
		3,500		2.37	1.16	.49	.16	.03						11	14	17	19	26	33					
		5,000	4.6	3.38	1.66	.70	.24	.05	97	123	156	218	294	212	212	210	210	210	208					
		7,500		5.08	2.49	1.05	.35	.07						14	16	20	23	29	36					
		10,000	5.3	6.77	3.32	1.39	.47	.09	102	127	160	222	301	212	212	212	212	210	210					
		15,000		10.2	4.99	2.09	.71	.14						18	20	24	27	33	39					
		20,000	5.8	13.5	6.65	2.79	.94	.18	104	131	164	224	305	212	212	212	212	210	210					
		25,000		16.9	8.31	3.49	1.18	.23						20	23	27	30	36	43					
50,000	8.2	33.8	16.6	6.97	2.35	.46	113	138	170	232	317	212	212	212	212	210	210							
75,000		50.8	24.9	10.5	3.53	.68						28	31	34	38	45	51							
100,000																								
150,000																								
200,000																								
250,000																								

(NOTE) For speeds not shown on the pump hydraulic charts, consult factory.



RS

PUMP HYDRAULIC SIZE CHART

SEC. 500

Page 127
January 2010

146 GPM
350 RPM

NOMINAL		ROTOR TRIM	VISCOSITY (SSU)	N.I.P.R. (PSIA)	FRICTION PIPE LOSS (PSI/FT) <small>(Based on Sch 40 Steel Pipe)</small>					FULL BYPASS RELIEF VALVE PRESSURE (PSI)					CAPACITY (GPM) / H.P. REQUIRED										
CAP. GPM	SPEED RPM				PIPE DIAMETER					CRACKING PRESS. (PSI)					DIFFERENTIAL PRESSURE (PSI)										
					2"	2 1/2"	3"	4"	6"	LOW PRES R/V			HI PRES R/V		MEDIUM DUTY AND HEAVY DUTY				HEAVY DUTY ONLY						
146	350	STD	28	1.8	.16	.07	.02	.01	-	56	84	120	177		135	131	128	124							
			32		.17	.07	.02	.01	-						2.6	4.9	6.9	9.1							
			38	1.8	.19	.08	.03	.01	-	59	86	122	179		136	133	130	127	121						
			50		.20	.09	.03	.01	-						3.2	5.6	7.8	9.4	15						
			70	1.8	.23	.10	.03	.01	-	62	89	124	182	241		139	136	134	131	127	125				
			100		.25	.11	.04	.01	-							3.9	6.1	8.7	10	15	19				
			150	1.8	.28	.12	.04	.01	-	65	92	126	185	244		142	139	138	136	133	132				
			200		.31	.13	.05	.01	-							4.8	6.7	9.1	11	15	20				
			300	1.8	.35	.15	.05	.01	-	71	97	130	189	249		143	142	141	140	138	137				
			500		.41	.12	.05	.02	-							4.9	7.3	9.2	11	16	20				
		750	1.9	.36	.18	.07	.03	-	74	100	133	192	252		145	144	144	143	142	141					
		1,000		.48	.24	.10	.03	.01							5	7.6	9.4	12	16	20					
		2,000	2.5	.97	.47	.20	.07	.01	81	109	138	197	257		143	142	142	141	140	139					
		3,500		1.69	.83	.35	.12	.02							5.2	9.5	10	12	17	21					
		5,000	3.0	2.42	1.19	.50	.17	.03	85	111	141	200	261		143	143	142	142	141	140					
		7,500		3.63	1.78	.75	.25	.05							6.9	9.3	12	13	19	22					
		10,000	3.7	4.83	2.37	1.00	.34	.07	88	114	144	203	265		144	143	142	142	142	141					
		15,000		7.25	3.56	1.49	.50	.10							8.8	11	14	15	20	24					
		20,000	4.4	9.67	4.75	1.99	.67	.13	91	116	145	204	267		144	143	143	143	142	142					
		25,000		12.1	5.94	2.49	.84	.16							11	13	15	17	22	26					
50,000	6.8	24.2	11.9	4.98	1.68	.33	97	122	149	210	272		144	143	143	143	142	142							
75,000		36.3	17.8	7.47	2.52	.49							15	18	20	23	27	32							
100,000	9.0	48.4	23.8	9.96	3.36	.65	101	125	152	212	275		144	143	143	143	142	142							
150,000		72.5	35.6	14.9	5.04	.98							20	23	25	28	33	37							
200,000																									
250,000																									

(NOTE) For speeds not shown on the pump hydraulic charts, consult factory.



RS

SEC. 500

PAGE 127.1

February 2025

42 GPM
100 RPM

NOMINAL		VISCOSITY		N.I.P.R.	FRICTION PIPE LOSS (PSI/FT) <small>(Schedule 40 Steel Pipe)</small>					CAPACITY (GPM)				H.P. REQUIRED						
GPM	RPM	ROTOR TRIM	(SSU)	(PSIa)	PIPE DIAMETER					MEDIUM-DUTY & HEAVY-DUTY				HEAVY-DUTY ONLY						
					2½"	3"	4"	5"	6"	DIFFERENTIAL PRESSURE (PSI)										
										25	50	75	100	150	200	300	400			
42	100	STD																		
				"D"																
			200,000	3.2	13.3	5.6	1.9	0.8	0.4	42	42	41	41	41	41	41	41	40		
			399,999		NR	11.2	3.8	1.5	0.7	4.4	4.9	5.4	5.9	7.0	7.9	9.0	11			
			400,000	3.6						42	42	41	41	41	41	41	40			
			599,999		NR	16.7	5.6	2.3	1.1	4.7	5.2	5.8	6.3	7.3	8.3	9.4	11			
			600,000	4.4						42	42	41	41	41	41	41	40			
			799,999		NR	22.3	7.5	3.1	1.5	5.0	5.5	6.1	6.6	7.6	8.7	9.8	12			
			800,000	4.9						42	42	41	41	41	41	41	40			
			1M		NR	NR	9.4	3.8	1.8	5.2	5.8	6.4	6.9	7.9	9.0	10	12			

(NOTE) For speeds not shown on the pump hydraulic charts, consult factory.