

**GHC SERIES
 HEAVY DUTY COMPACT
 STEEL ROTARY GEAR PUMP**

This heavy duty series pump is ideal for refining, petrochemical and applications requiring extra strength or shock resistance. The steel construction conforms to ASTM designation A216 Grade WCB. Superior rotor shaft support and an integral, maintenance-free radial/thrust bearing, reduce deflection and wear.



The GHC steel series is designed for applications in the operating ranges noted on the model pages. These units are available with head jackets for temperature control, carbon graphite bushings for low viscosity liquids, silicon carbide bushings for wear resistance, and numerous shaft seal options described on the following pages. These units may be foot mounted or, by using a motor adaptor, direct connected to NEMA "C" flange motors.

FEATURES

- 400 PSI CAPABILITY
- BALL BEARING THRUST CONTROL
- ROTOR END CLEARANCE EXTERNALLY ADJUSTABLE
- HIGH STRENGTH, COMPUTER PROFILED GEARING FOR QUIET OPERATION
- MULTIPLE PORT POSITIONS
- INTERNAL SEAL VENT

OPERATING RANGE

CAPACITY	(GPM) :	(3 TO 107)
	[LPM] :	[11 TO 405]
PRESSURE	(PSI) :	[0 TO 300]
	[BAR] :	[0 TO 21]
VISCOSITY	(SSU) :	(28 TO 25,000)
	[cSt] :	[1 TO 5417]
TEMPERATURE	(F) :	(-20° TO 350°)
	[C] :	[-29° TO 177°]

APPLICATIONS

- USE WITH ANY CLEAN LIQUID COMPATIBLE WITH IRON/STEEL
- ★ BOOSTER SERVICE
 - ★ CIRCULATING
 - ★ FILTERING
 - ★ LUBRICATING
 - ★ TRANSFERRING

EXTERIOR	BACKHD	ROTOR & IDLER	HOUSING PORTS	BUSHING	IDLER PIN	SHAFT	SHAFT SEALING		ROTA-TION	INTERNAL RELIEF VALVE	
							MECH. SEAL ●	PACKING ■		MATERIAL	SETTING
STEEL ③	DUCTILE IRON	HIGH STRENGTH IRON	150# FLG GHC 180° GHS 90°	BRONZE	HARD STEEL	STEEL	VITON	CARBON FIBER	C.W.	STEEL	75 PSI [5 BAR]

Standard Models

G H C 3 JG 32 - B
G H S 3 JG 32 - B
 | | | | | | | | | | | |
 GEAR DUTY DESIGN PORT SIZE HYDRAULIC SEAL STYLE

MODEL NUMBER		NOM. CAPACITY - SPEED				MAXIMUM				SHIPPING DATA		
		MAXIMUM		ALTERNATIVE		DIFF. PRESSURE - PSI [BAR]			TEMP	Wt.	Vol.	
		GPM [LPM]	RPM 60 Hz [50 HZ]	GPM [LPM]	RPM 60 Hz [50 HZ]	BELOW 38 SSU [4 cSt]	38 TO 100 SSU [21 cSt]	100 TO 250,000 SSU [55,000 cSt]	°F [°C]	LBS [KG]	CU. FT.	
GHC	GHS					100 [7]	150 [10]					
GHC 1 DC32-B ① ● †		9 [28]		6 [19]						39 [17,7]	0.6	
GHC 1 DE32-B ① ● †		11 [35]		7 [22]						39 [17,7]	0.6	
GHC 1-1/2 GC32-B ● †	GHS 1-1/2 GC32-B ● † GHS 1-1/2 GC38-B ■ †	16 [50]	1750 [1460]	10 [32]	1150 [960]			300 [21]	GHC ●	71 [32,2]	2.9	
GHC 1-1/2 GF32-B ● †	GHS 1-1/2 GF32-B ● † GHS 1-1/2 GF38-B ■ †	23 [73]		15 [47]						350 [177]	71 [32,2]	2.9
GHC 1-1/2 GH32-B ● †	GHS 1-1/2 GH32-B ● † GHS 1-1/2 GH38-B ■ †	31 [98]		20 [63]						GHS ●	71 [32,2]	2.9
GHC 1-1/2 GJ32-B ② ● †	GHS 1-1/2 GJ32-B ② ● † GHS 1-1/2 GJ38-B ② ■ †	38 [120]		25 [79]						400 [204]	71 [32,2]	2.9
GHC 3 JG32-B ● †	GHS 3 JG32-B ● † GHS 3 JG38-B ■ †	40 [126]	1150 [960]	30 [95]	870 [725]				500 [260]	154 [69,8]	5.3	
GHC 3 JJ32-B ● †	GHS 3 JJ32-B ● † GHS 3 JJ38-B ■ †	56 [177]		36 [114]				300 [21]			154 [69,8]	5.3
GHC 3 JL32-B ● †	GHS 3 JL32-B ● † GHS 3 JL38-B ■ †	77 [243]		58 [183]							154 [69,8]	5.3
GHC 3 JP32-B ② ● †	GHS 3 JP32-B ② ● † GHS 3 JP38-B ② ■ †	107 [338]		81 [256]						200 [14]		154 [69,8]

STANDARD MODELS
CONTINUED

NOTE: RECOMMENDED PORT SIZES ARE SHOWN IN **BOLDFACE**. EXAMPLE: **GHC 3 JG32-B, GHS 3 JG32-B**

- MECHANICAL SEAL
- LIPSEAL/PACKING
- † PORTS ARE COMPATIBLE WITH 150# ANSI FLANGES. ALL OTHER PORTS ARE TAPPED NPT FOR ANSI PIPE. OPTIONAL [DIN] FLANGES OR TAPPED [BSP] PORTS AVAILABLE FOR EXPORT MARKET.

- ① 3450 [2875] RPM PERMISSIBLE TO 1,000 SSU [220 cSt] AND 100 PSI [7 BAR]
- ② PUMP LIMITED TO 200 PSI MAXIMUM PRESSURE.
- ③ REFER TO REFERENCE SECTION FOR SPECIFIC CONSTRUCTION DETAILS.

THE GORMAN-RUPP COMPANY • MANSFIELD, OHIO
GORMAN-RUPP OF CANADA LIMITED • ST. THOMAS, ONTARIO, CANADA

MODEL NUMBER		NOM. CAPACITY - SPEED				MAXIMUM				SHIPPING DATA	
		MAXIMUM		ALTERNATIVE		DIFF. PRESSURE - PSI [BAR]			TEMP.	Wt.	Vol.
		GPM	RPM	GPM	RPM	BELOW	38 TO	100 TO	° F		
GHC	GHS	[LPM]	60 Hz	[LPM]	60 Hz	38 SSU	100 SSU	250,000 SSU	[° C]	LBS	CU. FT.
			[50 HZ]		[50 HZ]	[4 cSt]	[21 cSt]	[55,000 cSt]		[KG]	
	GHS 2 NK32-B ● † GHS 2 NK38-B ■ †	99 [375]		60 [189]				300 [21]		200	5.3
										[90,7]	
	GHS 3 NK32-B ● † GHS 3 NK38-B ■ †	132 [500]	960 [960]	80 [252]	580 [480]					200	5.3
										[90,7]	
	GHS 2 NM32-B ● † GHS 2 NM38-B ■ †	165 [624]		99 [312]						200	5.3
										[90,7]	
	GHS 3 NP32-B ① ● † GHS 3 NP38-B ① ■ †	172 [542]		115 [362]					GHS ● 400 [204]	302	10.7
										[136,9]	
	GHS 2-1/2 RM32-B ● † GHS 2-1/2 RM38-B ■ †	215 [678]	720 [600]	143 [451]	480 [400]	100 [7]	150 [10]	300 [21]		302	10.7
										[136,9]	
	GHS 3 RM32-B ● † GHS 3 RM38-B ■ †	255 [804]		170 [536]						302	10.7
										[136,9]	
	GHS 4 RM32-B ● † GHS 4 RM38-B ■ †	295 [930]		196 [618]						302	10.7
										[136,9]	
	GHS 2-1/2 RP32-B ● † GHS 2-1/2 RP38-B ■ †	255 [804]		170 [536]						302	10.7
										[136,9]	
	GHS 3 RP32-B ● † GHS 3 RP38-B ■ †	295 [930]		196 [618]						302	10.7
										[136,9]	
	GHS 4 RP32-B ● † GHS 4 RP38-B ■ †	295 [930]		196 [618]						302	10.7
										[136,9]	
	GHS 3 RR32-B ● † GHS 3 RR38-B ■ †	295 [930]		196 [618]						302	10.7
										[136,9]	
	GHS 4 RR32-B ● † GHS 4 RR38-B ■ †	295 [930]		196 [618]						302	10.7
										[136,9]	
	GHS 3 RS32-B ① ● † GHS 3 RS38-B ① ■ †	295 [930]		196 [618]						302	10.7
										[136,9]	
	GHS 4 RS32-B ① ● † GHS 4 RS38-B ① ■ †	295 [930]		196 [618]						302	10.7
										[136,9]	

STANDARD MODELS CONTINUED

- MECHANICAL SEAL
- LIPSEAL/PACKING
- † PORTS ARE COMPATIBLE WITH 150# ANSI FLANGES. ALL OTHER PORTS ARE TAPPED NPT FOR ANSI PIPE. OPTIONAL [DIN] FLANGES OR TAPPED [BSP] PORTS AVAILABLE FOR EXPORT MARKET.

① PUMP LIMITED TO 200 PSI MAXIMUM PRESSURE.

THE GORMAN-RUPP COMPANY • MANSFIELD, OHIO
GORMAN-RUPP OF CANADA LIMITED • ST. THOMAS, ONTARIO, CANADA

APPLICATION RECOMMENDATIONS:		
APPLICATION	OPTIONS REQUIRED (Select One From Each Row)	OPERATING LIMITATIONS
GHS ONLY HIGH TEMPERATURE	25U, 25V, OR 25W 35J – 35M (AS REQ'D) 40M, 40W 61H, OR 65Q 70K	TEMPERATURE: 675° F MAX. PRESSURE: 200 PSI MAX.
ASPHALT	35J–35M (AS REQ'D) 40M, 40W, 40G 41R, 41W 65S 70, 70K, 71K	TEMPERATURE: 500° MAX.
JACKETED	40G, 40J, 40K, 40W, 41U, 41W	LIMIT JACKET PRESSURE TO 150 PSIG

NOTE: PROPER PUMP APPLICATION REQUIRES CONSIDERATION OF ADDITIONAL FACTORS. PLEASE REVIEW APPLICATION GUIDE IN SECTION 500 OR CONSULT THE FACTORY.

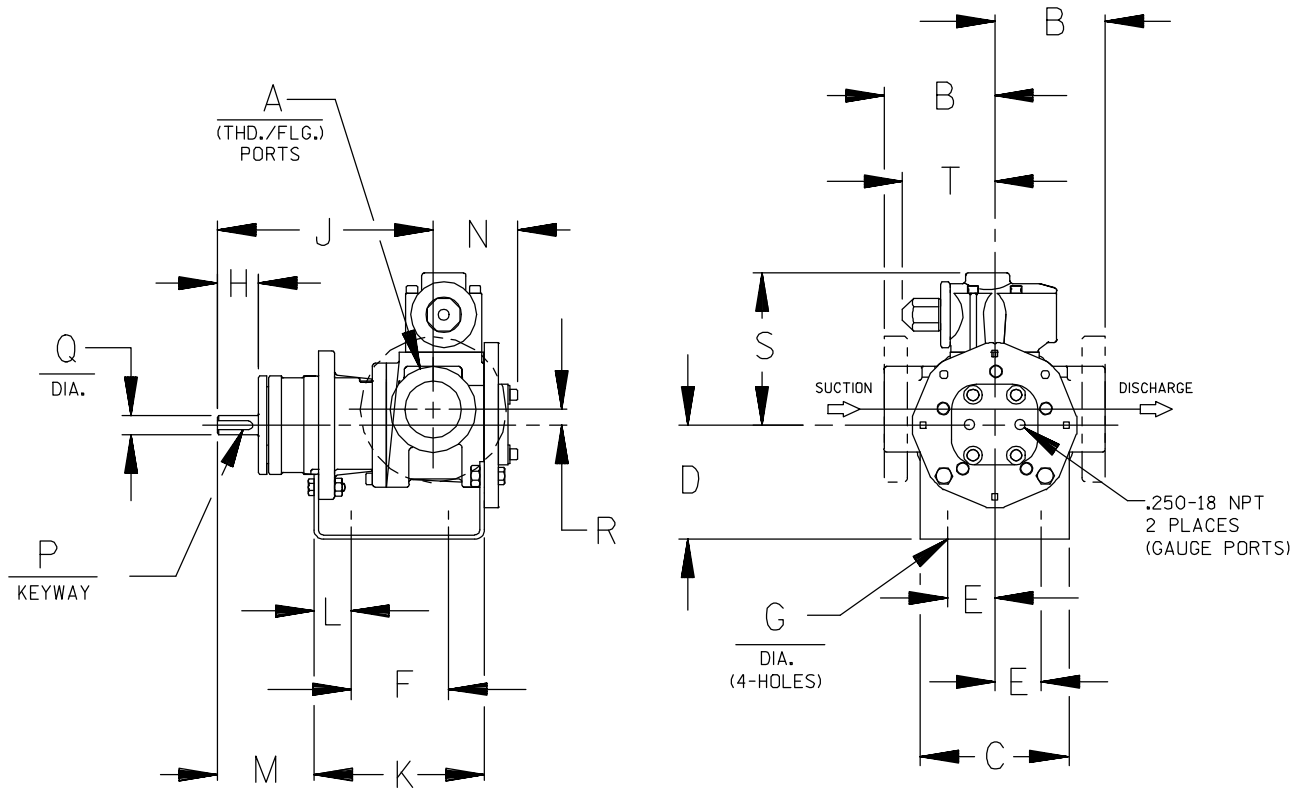

CAD FILE NO.: 16458D

MODEL NUMBERS	PUMP DIMENSIONS - INCHES [MILLIMETERS]																	
	A	B	C	D	E	F	G	H	J	K	L	M	N	P	Q	R	S	T
GHC D	1"	4.00 † [102]	4.00 [102]	3.50* [89] 4.50 [114] 5.25 [133]	1.62 [41]	3.12 [79]	.41 [10]	1.16 [30]	6.19 [157]	5.04 [128]	.76 [19]	2.62 [66]	2.74 [70]	.12 [3] x .75 [19]	.50 [13]	.62 [16]	5.19 [132]	3.58 [91]
GHC G	1-1/2"	4.00 † [102]	5.88 [149]	3.50* [89] 4.50 [114] 5.25 [133] 6.25 [159]	1.62 [41]	4.00 [102]	.41 [10]	1.62 [41]	8.50 [216]	6.71 [170]	1.06 [27]	3.82 [97]	3.35 [85]	.19 [5] x 1.25 [32]	.75 [19]	.62 [16]	6.00 [152]	3.62 [92]
GHC J	3"	6.00* [152] † 6.31 † [160]	6.88 [175]	4.50 [114] 5.25* [133] 6.25 [159] 7.00 [178] 8.00 [203]	2.88 [73]	4.25 [108]	.44 [11]	2.50 [64]	12.12 [308]	9.75 [248]	1.75 [44]	5.50 [140]	4.66 [118]	.25 [6] x 2.00 [51]	1.00 [25]	1.12 [28]	9.06 [230]	6.75 [171]

* STANDARD DIMENSION
PORTS ARE COMPATIBLE WITH 150# OR 300# ANSISTEEL FLANGES. ALL OTHER PORTS ARE TAPPED NPT
† FOR ANSIPipe. OPTIONAL [DIN FLANGES OR TAPPED [BSP] PORTS AVAILABLE FOR EXPORT MARKET.
NPT FOR ANSIPipe. OPTIONAL (DIN) FLANGES OR TAPPED (BSP) PORTS AVAILABLE FOR EXPORT MARKET.
‡ 90° HOUSING

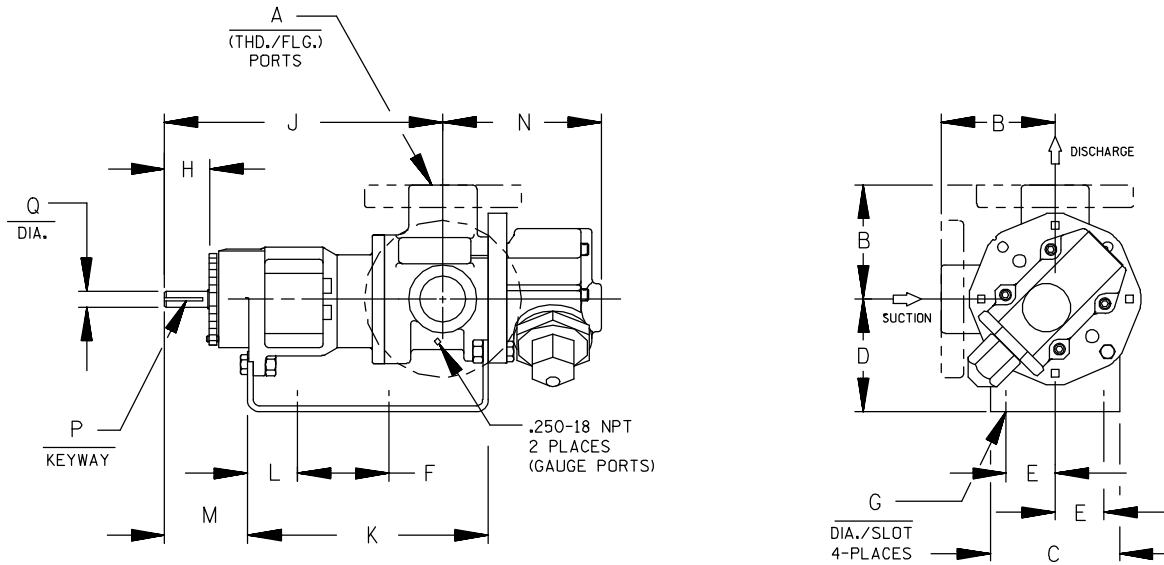

CAD FILE NO.: 16669F

MODEL NUMBERS	PUMP DIMENSIONS - INCHES [MILLIMETERS]														
	A	B	C	D	E	F	G	H	J	K	L	M	N	P	Q
GHS G	1-1/2"	4.00 [102]	4.88 [124]	3.50* [89] 4.50 [114] 5.25 [133] 6.25 [159]	1.62 [41]	8.00 [203]	.41 [10]	1.62 [41]	12.06 [306]	10.72 [272]	1.52 [39]	3.35 [85]	5.70 [145]	.19 [5] x 1.25 [32]	.75 [19]
GHS J	3"	6.00† [152] 6.31 [160]	6.88 [175]	5.25* [133] 6.25 [159] 7.00 [178] 8.00 [203]	2.88 [73]	10.00 [254]	.44 [11]	2.50 [64]	15.68 [398]	14.31 [363]	2.77 [70]	4.48 [114]	8.50 [216]	.25 [6] x 2.00 [51]	1.00 [25]
GHS N	2"	5.25* [133] 5.38 [137]	8.00 [203]	4.50 [114] 5.25* [133]	2.88 [73]	10.00 [254]	.44 [11]	2.58 [66]	16.37 [416]	15.14 [385]	2.69 [68]	4.56 [116]	7.59 [193]	.25 [6] x 2.00 [51]	1.12 [32]
	3"	7.19 [183]		8.72* [221]											
GHS R	2-1/2"	7.19 [183]	10.50 [267]	7.00 [178]	3.75 [95]	13.75 [349]	.52 [13]	2.25 [57]	17.87 [454]	17.36 [441]	1.80 [46]	4.70 [119]	11.31 [287]	.38 [10] x 1.88 [48]	1.44 [37]
	3"														
	4"														

* STANDARD DIMENSION

† PORTS ARE COMPATIBLE WITH 150* OR 300* ANSISTEEL FLANGES. ALL OTHER PORTS ARE TAPPED NPT FOR ANSIPIPE. OPTIONAL (DIN) FLANGES OR TAPPED (BSP) PORTS AVAILABLE FOR EXPORT MARKET.

† 180° HOUSING

GHC/GHS

FOR GHC DRIVE OPTIONS

AND DIMENSIONS

SEE

SECTION 540

FOR GHS DRIVE OPTIONS

AND DIMENSIONS

SEE

SECTION 545

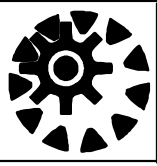

PERFORMANCE CURVES

SPEED VS. CAPACITY/HORSEPOWER

JP

Hydraulic
Size

SEC. 500

Page 80

January 2010

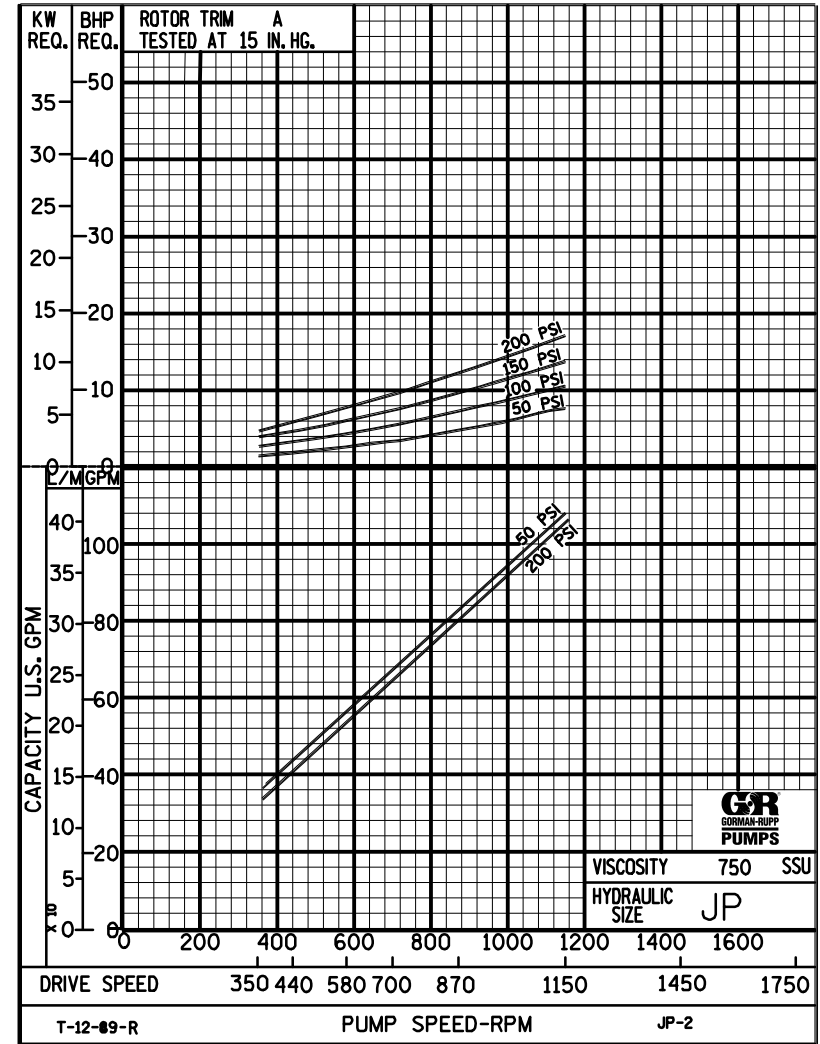
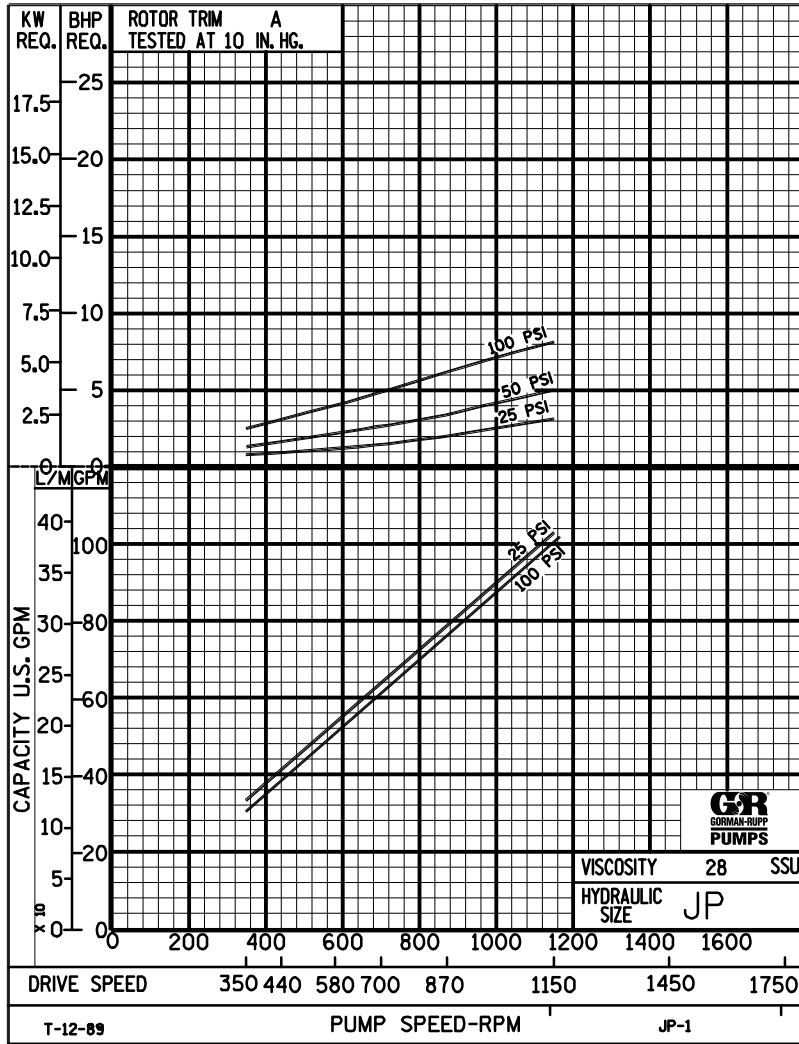

THE GORMAN-RUPP COMPANY • MANSFIELD, OHIO
 GORMAN-RUPP OF CANADA LIMITED • ST. THOMAS, ONTARIO, CANADA

Printed in U.S.A.

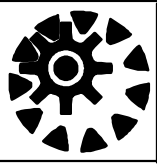

PERFORMANCE CURVES

SPEED VS. CAPACITY/HORSEPOWER

JP Hydraulic Size

SEC. 500

Page 81

January 2010

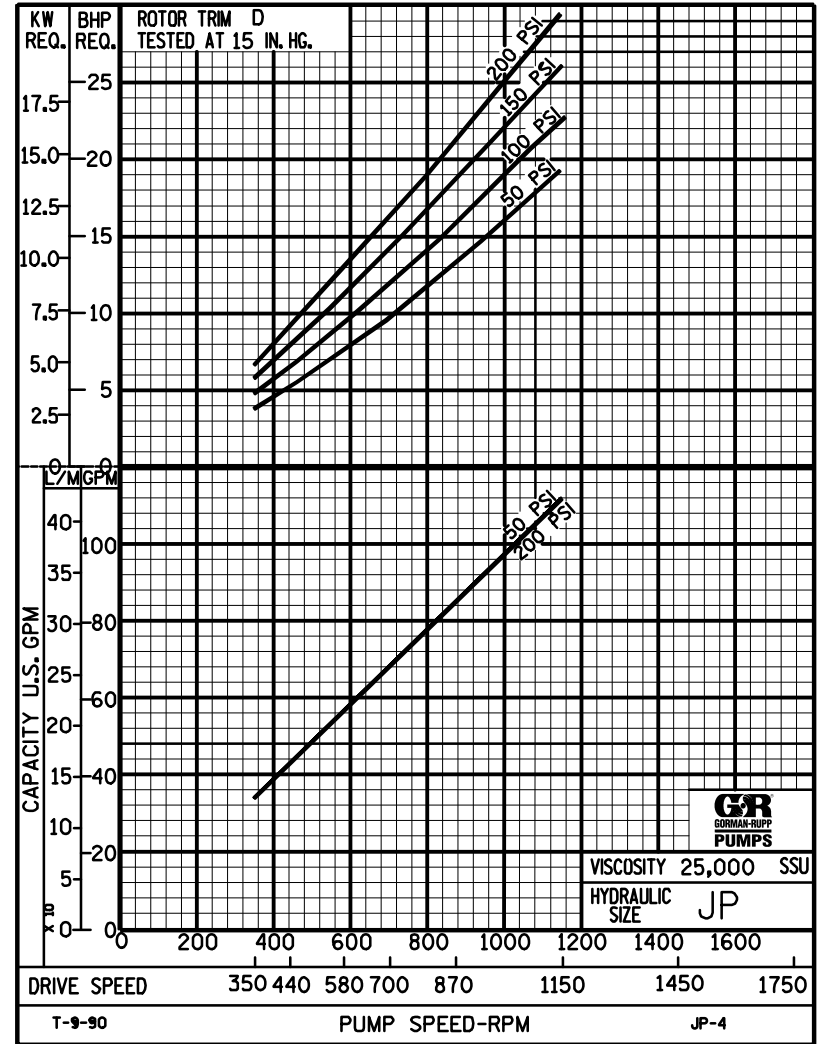
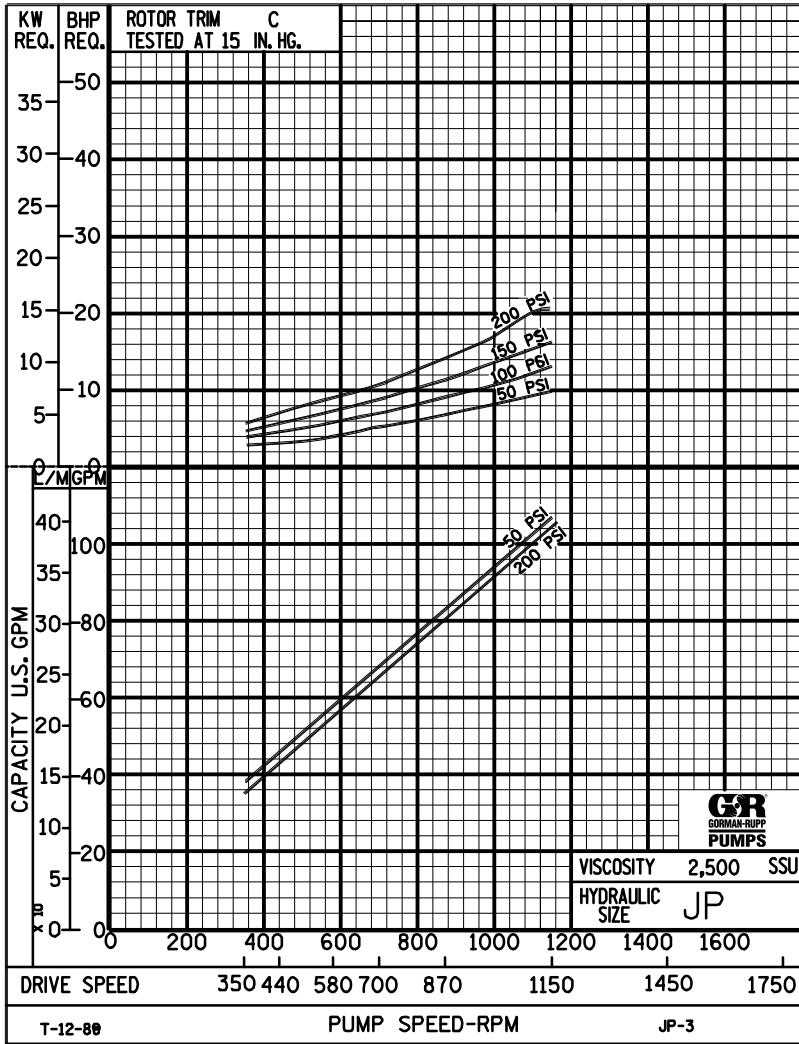

THE GORMAN-RUPP COMPANY • MANSFIELD, OHIO
 GORMAN-RUPP OF CANADA LIMITED • ST. THOMAS, ONTARIO, CANADA

Printed in U.S.A.

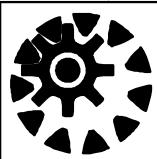

JP

PUMP HYDRAULIC SIZE CHART

SEC. 500

Page 82

January 2010

107 GPM
1150 RPM

NOMINAL		ROTOR TRIM	VISCOSITY (SSU)	N.I.P.R. (PSIA)	FRICTION PIPE LOSS (PSI/FT) <small>(Based on Sch 40 Steel Pipe)</small>					FULL BYPASS RELIEF VALVE PRESSURE (PSI)					CAPACITY (GPM) / H.P. REQUIRED												
CAP. GPM	SPEED RPM				PIPE DIAMETER					CRACKING PRESS. (PSI)					DIFFERENTIAL PRESSURE (PSI)												
					1½"	2"	2½"	3"	4"	LOW PRES R/V			HI PRES R/V		HEAVY DUTY												
							50	75	100	150	200	25	50	75	100	150	200	300	400								
107	1150	STD	28	4.8	.01	.01	.01	.01	.01	77	104	143				103	100	100	99								
			32		.23	.07	.03	.01	.01							3.2	5.0	6.3	8.1								
			38	4.8	.29	.09	.04	.02	.01	78	105	144	188				105	103	102	101	100						
			50		.34	.11	.05	.02	.01								3.5	5.5	6.8	8.6	12						
			70	4.8	.39	.12	.05	.02	.01	79	107	144	189	240				106	105	104	103	102	101				
			100		.44	.14	.06	.02	.01									3.8	6.0	7.4	9.1	13	16				
			150	4.8	.50	.15	.07	.03	.01	80	107	145	189	241				108	106	106	105	104	103				
			200		.54	.17	.07	.03	.01									4.1	6.5	8.0	9.6	13	16				
			300	4.8	.61	.19	.08	.03	.01	81	109	145	190	242				109	108	107	107	106	105				
			500		.64	.22	.09	.04	.01									4.4	7.1	8.5	10	14	17				
		750	4.8	.70	.26	.13	.06	.02	82	111	146	190	243				109	109	108	108	108	107					
		1,000		.94	.35	.17	.07	.03									4.7	7.6	9.1	11	14	17					
		2,000	5.7	1.87	.69	.34	.14	.05	86	118	153	196	252				109	109	109	108	108	108					
		3,500		3.28	1.21	.59	.25	.09									6.1	9.9	12	13	16	20					
		5,000	6.2	4.68	1.73	.85	.36	.12	90	123	156	200	256				110	110	109	109	109	109					
		7,500		7.02	2.59	1.27	.54	.18									9.9	13	15	16	20	23					
		10,000	6.8	9.36	3.45	1.70	.71	.24	96	129	160	204	260				110	110	110	109	109	109					
		15,000		14.1	5.17	2.54	1.07	.36									14	16	18	19	23	26					
		20,000	7.3	18.7	6.89	3.39	1.42	.48	102	135	164	208	264				111	110	110	110	109	109					
		25,000		23.4	8.62	4.23	1.78	.60									18	19	21	23	26	30					
50,000																											
75,000																											
100,000																											
150,000																											
200,000																											
250,000																											

(NOTE) For speeds not shown on the pump hydraulic charts, consult factory.

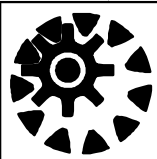

JP

PUMP HYDRAULIC SIZE CHART

SEC. 500

Page 83

January 2010

**81 GPM
870 RPM**

NOMINAL		ROTOR TRIM	VISCOSITY (SSU)	N.I.P.R. (PSIA)	FRICTION PIPE LOSS (PSI/FT) <small>(Based on Sch 40 Steel Pipe)</small>					FULL BYPASS RELIEF VALVE PRESSURE (PSI)					CAPACITY (GPM) / H.P. REQUIRED									
CAP. GPM	SPEED RPM				PIPE DIAMETER					CRACKING PRESS. (PSI)					DIFFERENTIAL PRESSURE (PSI)									
					1½"	2"	2½"	3"	4"	LOW PRES R/V			HI PRES R/V		MEDIUM DUTY AND HEAVY DUTY				HEAVY DUTY ONLY					
							50	75	100	150	200	25	50	75	100	150	200	300	400					
81	870	STD	28	3.0	.01	.01	.01	.01	.01	74	100	133			77	75	75	74						
			32		.14	.04	.02	.01	.01						2.2	3.4	4.7	6.0						
			38	3.0	.18	.06	.03	.01	.01	74	100	133	174			78	77	76	75	75				
			50		.21	.07	.03	.01	.01							2.3	3.7	5.0	6.2	7.5				
			70	3.0	.24	.08	.03	.01	.01	74	101	134	174	226			79	78	78	77	76	75		
			100		.27	.09	.04	.02	.01								2.5	4.0	5.2	6.5	8.0	10		
			150	3.0	.31	.10	.04	.02	.01	75	101	134	175	226			81	79	79	78	78	77		
			200		.34	.11	.05	.02	.01								2.6	4.3	5.5	6.8	8.6	11		
			300	3.0	.38	.12	.05	.02	.01	75	102	135	175	227			81	81	80	79	79	78		
			500		.44	.13	.07	.03	.01								2.8	4.5	5.8	7.0	9.2	12		
		750	3.0	.53	.20	.10	.04	.02	75	102	135	175	227			82	81	81	80	80.5	80			
		1,000		.71	.26	.13	.06	.02								3.0	4.8	6.0	7.3	9.7	12			
		2,000	3.7	1.42	.52	.26	.11	.04	76	104	137	177	229			82	82	81	81	81	81			
		3,500		2.48	.92	.45	.19	.07								4.2	6.8	7.9	9.0	12	14			
		5,000	4.2	3.55	1.31	.64	.27	.09	80	109	139	179	231			83	83	82	82	82	82			
		7,500		5.32	1.96	.96	.41	.14								6.8	9.0	10	11	14	16			
		10,000	4.6	7.09	2.61	1.28	.54	.18	84	114	143	183	235			84	84	83	83	83	82			
		15,000		10.7	3.92	1.92	.81	.27								9.3	11	12	14	16	19			
		20,000	5.0	14.2	5.22	2.57	1.08	.37	89	120	149	187	241			85	84	84	84	84	83			
		25,000		17.7	6.52	3.21	1.35	.46								12	13	14	16	18	21			
50,000	7.6	35.5	13.1	6.41	2.69	.91	95	126	155	193	247			85	84	84	84	84	83					
75,000		-	-	-	-	-								17	18	21	23	24	27					
100,000																								
150,000																								
200,000																								
250,000																								

(NOTE) For speeds not shown on the pump hydraulic charts, consult factory.

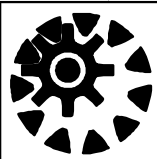

JP

PUMP HYDRAULIC SIZE CHART

SEC. 500

Page 84

January 2010

**54 GPM
580 RPM**

NOMINAL		ROTOR TRIM	VISCOSITY (SSU)	N.I.P.R. (PSIA)	FRICTION PIPE LOSS (PSI/FT) <small>(Based on Sch 40 Steel Pipe)</small>					FULL BYPASS RELIEF VALVE PRESSURE (PSI)					CAPACITY (GPM) / H.P. REQUIRED								
CAP. GPM	SPEED RPM				PIPE DIAMETER					CRACKING PRESS. (PSI)					DIFFERENTIAL PRESSURE (PSI)								
					1½"	2"	2½"	3"	4"	LOW PRES R/V			HI PRES R/V		MEDIUM DUTY AND HEAVY DUTY				HEAVY DUTY ONLY				
							50	75	100	150	200	25	50	75	100	150	200	300	400				
54	580	STD	28	1.9	.01	.01	.01	.01	.01	62	87	114			51	50	50	49					
			32		.07	.02	.01	.01	.01							1.5	2.3	3.1	4.0				
			38	1.9	.09	.03	.01	.01	.01	62	89	116	166			52	51	51	50	50			
			50		.10	.03	.02	.01	.01							1.6	2.5	3.3	4.2	5.0			
			70	1.9	.12	.04	.02	.01	.01	63	90	118	167	219			53	52	52	51	51	50	
			100		.14	.04	.02	.01	.01							1.7	2.7	3.5	4.4	5.4	6.9		
			150	1.9	.16	.05	.02	.01	.01	64	91	120	167	219			54	53	53	52	52	51	
			200		.17	.05	.02	.01	.01							1.8	2.9	3.7	4.5	5.8	7.3		
			300	1.9	.19	.06	.03	.01	.01	65	92	122	168	220			54	54	53	53	53	52	
			500		.24	.09	.05	.02	.01							1.9	3.0	3.9	4.7	6.2	7.8		
		750	1.9	.36	.13	.07	.03	.01	66	93	124	168	220			54	54	54	54	54	53		
		1,000		.47	.18	.09	.04	.01							2.0	3.2	4.0	4.9	6.5	8.2			
		2,000	2.6	.95	.35	.17	.07	.03	70	95	124	168	222			55	55	54	54	54	54		
		3,500		1.66	.61	.30	.13	.04							2.8	4.6	5.3	6.1	7.8	9.5			
		5,000	3.0	2.36	.87	.43	.18	.06	72	97	126	170	224			55	55	55	55	55	54		
		7,500		3.55	1.31	.64	.27	.09							4.6	6.0	6.8	7.6	9.3	11			
		10,000	3.5	4.73	1.74	.86	.36	.12	74	99	128	172	226			56	56	56	55	55	55		
		15,000		7.09	2.61	1.28	.54	.18							6.3	7.4	8.2	9.1	11	13			
		20,000	3.9	9.45	3.48	1.71	.72	.24	78	103	128	174	226			57	56	56	56	56	56		
		25,000		11.8	4.35	2.14	.90	.30							8.0	8.9	9.6	11	12	14			
50,000	6.1	23.6	8.70	4.27	1.79	.61	82	107	132	178	230			57	56	56	56	56	56				
75,000		35.5	13.1	6.41	2.69	.91							11	12	14	16	16	18					
100,000																							
150,000																							
200,000																							
250,000																							

(NOTE) For speeds not shown on the pump hydraulic charts, consult factory.

