

**GHC SERIES
 HEAVY DUTY COMPACT
 STEEL ROTARY GEAR PUMP**

This heavy duty series pump is ideal for refining, petrochemical and applications requiring extra strength or shock resistance. The steel construction conforms to ASTM designation A216 Grade WCB. Superior rotor shaft support and an integral, maintenance-free radial/thrust bearing, reduce deflection and wear.



The GHC steel series is designed for applications in the operating ranges noted on the model pages. These units are available with head jackets for temperature control, carbon graphite bushings for low viscosity liquids, silicon carbide bushings for wear resistance, and numerous shaft seal options described on the following pages. These units may be foot mounted or, by using a motor adaptor, direct connected to NEMA "C" flange motors.

FEATURES

- 400 PSI CAPABILITY
- BALL BEARING THRUST CONTROL
- ROTOR END CLEARANCE EXTERNALLY ADJUSTABLE
- HIGH STRENGTH, COMPUTER PROFILED GEARING FOR QUIET OPERATION
- MULTIPLE PORT POSITIONS
- INTERNAL SEAL VENT

OPERATING RANGE

| | | |
|-------------|---------|----------------|
| CAPACITY | (GPM) : | (3 TO 107) |
| | [LPM] : | [11 TO 405] |
| PRESSURE | (PSI) : | [0 TO 300] |
| | [BAR] : | [0 TO 21] |
| VISCOSITY | (SSU) : | (28 TO 25,000) |
| | [cSt] : | [1 TO 5417] |
| TEMPERATURE | (F) : | (-20° TO 350°) |
| | [C] : | [-29° TO 177°] |

APPLICATIONS

- USE WITH ANY CLEAN LIQUID COMPATIBLE WITH IRON/STEEL
- ★ BOOSTER SERVICE
 - ★ CIRCULATING
 - ★ FILTERING
 - ★ LUBRICATING
 - ★ TRANSFERRING

| EXTERIOR | BACKHD | ROTOR & IDLER | HOUSING PORTS | BUSHING | IDLER PIN | SHAFT | SHAFT SEALING | | ROTA-TION | INTERNAL RELIEF VALVE | |
|----------|--------------|--------------------|---------------------------------|---------|------------|-------|---------------|--------------|-----------|-----------------------|----------------|
| | | | | | | | MECH. SEAL ● | PACKING ■ | | MATERIAL | SETTING |
| STEEL ③ | DUCTILE IRON | HIGH STRENGTH IRON | 150# FLG GHC 180° GHS 90° | BRONZE | HARD STEEL | STEEL | VITON | CARBON FIBER | C.W. | STEEL | 75 PSI [5 BAR] |

Standard Models

G H C 3 JG 32 - B
G H S 3 JG 32 - B
 | | | | | | | | | | | |
 GEAR DUTY DESIGN PORT SIZE HYDRAULIC SEAL STYLE

| MODEL NUMBER | | NOM. CAPACITY - SPEED | | | | MAXIMUM | | | | SHIPPING DATA | | |
|------------------------|--|-----------------------|-------------------|-------------|-------------------|----------------------------|------------------------|---------------------------------|-----------|---------------|--------------|------------|
| | | MAXIMUM | | ALTERNATIVE | | DIFF. PRESSURE - PSI [BAR] | | | TEMP | | | |
| | | GPM [LPM] | RPM 60 Hz [50 HZ] | GPM [LPM] | RPM 60 Hz [50 HZ] | BELOW 38 SSU [4 cSt] | 38 TO 100 SSU [21 cSt] | 100 TO 250,000 SSU [55,000 cSt] | °F [°C] | Wt. LBS [KG] | Vol. CU. FT. | |
| GHC | GHS | | | | | | | | | | | |
| GHC 1 DC32-B ① ● † | | 9 [28] | | 6 [19] | | | | | | 39 [17,7] | 0.6 | |
| GHC 1 DE32-B ① ● † | | 11 [35] | | 7 [22] | | | | | | 39 [17,7] | 0.6 | |
| GHC 1-1/2 GC32-B ● † | GHS 1-1/2 GC32-B ● † GHS 1-1/2 GC38-B ■ † | 16 [50] | 1750 [1460] | 10 [32] | 1150 [960] | | | 300 [21] | GHC ● | 71 [32,2] | 2.9 | |
| GHC 1-1/2 GF32-B ● † | GHS 1-1/2 GF32-B ● † GHS 1-1/2 GF38-B ■ † | 23 [73] | | 15 [47] | | | | | | 350 [177] | 71 [32,2] | 2.9 |
| GHC 1-1/2 GH32-B ● † | GHS 1-1/2 GH32-B ● † GHS 1-1/2 GH38-B ■ † | 31 [98] | | 20 [63] | | | | | | GHS ● | 71 [32,2] | 2.9 |
| GHC 1-1/2 GJ32-B ② ● † | GHS 1-1/2 GJ32-B ② ● † GHS 1-1/2 GJ38-B ② ■ † | 38 [120] | | 25 [79] | | | | 100 [7] | 150 [10] | 200 [14] | 400 [204] | 71 [32,2] |
| GHC 3 JG32-B ● † | GHS 3 JG32-B ● † GHS 3 JG38-B ■ † | 40 [126] | 1150 [960] | 30 [95] | 870 [725] | | | | 500 [260] | 154 [69,8] | 5.3 | |
| GHC 3 JJ32-B ● † | GHS 3 JJ32-B ● † GHS 3 JJ38-B ■ † | 56 [177] | | 36 [114] | | | | | | 300 [21] | 154 [69,8] | 5.3 |
| GHC 3 JL32-B ● † | GHS 3 JL32-B ● † GHS 3 JL38-B ■ † | 77 [243] | | 58 [183] | | | | | | | 154 [69,8] | 5.3 |
| GHC 3 JP32-B ② ● † | GHS 3 JP32-B ② ● † GHS 3 JP38-B ② ■ † | 107 [338] | | 81 [256] | | | | | | 200 [14] | | 154 [69,8] |

STANDARD MODELS
CONTINUED

NOTE: RECOMMENDED PORT SIZES ARE SHOWN IN **BOLDFACE**. EXAMPLE: **GHC 3 JG32-B, GHS 3 JG32-B**

- MECHANICAL SEAL
- LIPSEAL/PACKING
- † PORTS ARE COMPATIBLE WITH 150# ANSI FLANGES. ALL OTHER PORTS ARE TAPPED NPT FOR ANSI PIPE. OPTIONAL [DIN] FLANGES OR TAPPED [BSP] PORTS AVAILABLE FOR EXPORT MARKET.

- ① 3450 [2875] RPM PERMISSIBLE TO 1,000 SSU [220 cSt] AND 100 PSI [7 BAR]
- ② PUMP LIMITED TO 200 PSI MAXIMUM PRESSURE.
- ③ REFER TO REFERENCE SECTION FOR SPECIFIC CONSTRUCTION DETAILS.

THE GORMAN-RUPP COMPANY • MANSFIELD, OHIO
GORMAN-RUPP OF CANADA LIMITED • ST. THOMAS, ONTARIO, CANADA

| MODEL NUMBER | | NOM. CAPACITY - SPEED | | | | MAXIMUM | | | | SHIPPING DATA | | |
|--------------|--|-----------------------|-------------------------|--------------|-------------------------|----------------------------|------------------------------|---------------------------------------|------------|--------------------|-----------------|--------------|
| | | MAXIMUM | | ALTERNATIVE | | DIFF. PRESSURE - PSI [BAR] | | | TEMP. | Wt. LBS [KG] | Vol. CU. FT. | |
| | | GPM [LPM] | RPM 60 Hz [50 HZ] | GPM [LPM] | RPM 60 Hz [50 HZ] | BELOW 38 SSU [4 cSt] | 38 TO 100 SSU [21 cSt] | 100 TO 250,000 SSU [55,000 cSt] | °F [°C] | | | |
| GHC | GHS | | | | | | | | | | | |
| | GHS 2 NK32-B ● † GHS 2 NK38-B ■ † | 99 [375] | 960 [960] | 60 [189] | 580 [480] | | | 300 [21] | | 200 [90,7] | 5.3 | |
| | GHS 3 NK32-B ● † GHS 3 NK38-B ■ † | | | | | | | | | 200 [90,7] | | 5.3 |
| | GHS 2 NM32-B ● † GHS 2 NM38-B ■ † | 132 [500] | 960 [960] | 80 [252] | 580 [480] | | | 300 [21] | | 200 [90,7] | 5.3 | |
| | GHS 3 NM32-B ● † GHS 3 NM38-B ■ † | | | | | | | | | 200 [90,7] | | 5.3 |
| | GHS 3 NP32-B ① ● † GHS 3 NP38-B ① ■ † | 165 [624] | 960 [960] | 99 [312] | 580 [480] | | | 300 [21] | | 200 [90,7] | 5.3 | |
| | GHS 2-1/2 RM32-B ● † GHS 2-1/2 RM38-B ■ † | 172 [542] | | 720 [600] | | | | | | 143 [451] | | 480 [400] |
| | GHS 3 RM32-B ● † GHS 3 RM38-B ■ † | | 302 [136,9] | | 10.7 | | | | | | | |
| | GHS 4 RM32-B ● † GHS 4 RM38-B ■ † | 215 [678] | 720 [600] | 143 [451] | 480 [400] | 100 [7] | 150 [10] | 300 [21] | | 302 [136,9] | 10.7 | |
| | GHS 3 RP32-B ● † GHS 3 RP38-B ■ † | | | | | | | | | 302 [136,9] | | 10.7 |
| | GHS 4 RP32-B ● † GHS 4 RP38-B ■ † | 255 [804] | 720 [600] | 170 [536] | 480 [400] | 100 [7] | 150 [10] | 300 [21] | | 302 [136,9] | 10.7 | |
| | GHS 3 RR32-B ● † GHS 3 RR38-B ■ † | | | | | | | | | 302 [136,9] | | 10.7 |
| | GHS 4 RR32-B ● † GHS 4 RR38-B ■ † | 295 [930] | 720 [600] | 196 [618] | 480 [400] | 100 [7] | 150 [10] | 300 [21] | | 302 [136,9] | 10.7 | |
| | GHS 3 RS32-B ① ● † GHS 3 RS38-B ① ■ † | | | | | | | | | 302 [136,9] | | 10.7 |
| | GHS 4 RS32-B ① ● † GHS 4 RS38-B ① ■ † | | | | | | | | | 302 [136,9] | 10.7 | |

STANDARD MODELS CONTINUED

- MECHANICAL SEAL
- LIPSEAL/PACKING
- † PORTS ARE COMPATIBLE WITH 150# ANSI FLANGES. ALL OTHER PORTS ARE TAPPED NPT FOR ANSI PIPE. OPTIONAL [DIN] FLANGES OR TAPPED [BSP] PORTS AVAILABLE FOR EXPORT MARKET.

① PUMP LIMITED TO 200 PSI MAXIMUM PRESSURE.

THE GORMAN-RUPP COMPANY • MANSFIELD, OHIO
 GORMAN-RUPP OF CANADA LIMITED • ST. THOMAS, ONTARIO, CANADA

| APPLICATION RECOMMENDATIONS: | | |
|-------------------------------------|--|--|
| APPLICATION | OPTIONS REQUIRED (Select One From Each Row) | OPERATING LIMITATIONS |
| GHS ONLY HIGH TEMPERATURE | 25U, 25V, OR 25W 35J – 35M (AS REQ'D) 40M, 40W 61H, OR 65Q 70K | TEMPERATURE: 675° F MAX. PRESSURE: 200 PSI MAX. |
| ASPHALT | 35J–35M (AS REQ'D) 40M, 40W, 40G 41R, 41W 65S 70, 70K, 71K | TEMPERATURE: 500° MAX. |
| JACKETED | 40G, 40J, 40K, 40W, 41U, 41W | LIMIT JACKET PRESSURE TO 150 PSIG |

NOTE: PROPER PUMP APPLICATION REQUIRES CONSIDERATION OF ADDITIONAL FACTORS. PLEASE REVIEW APPLICATION GUIDE IN SECTION 500 OR CONSULT THE FACTORY.

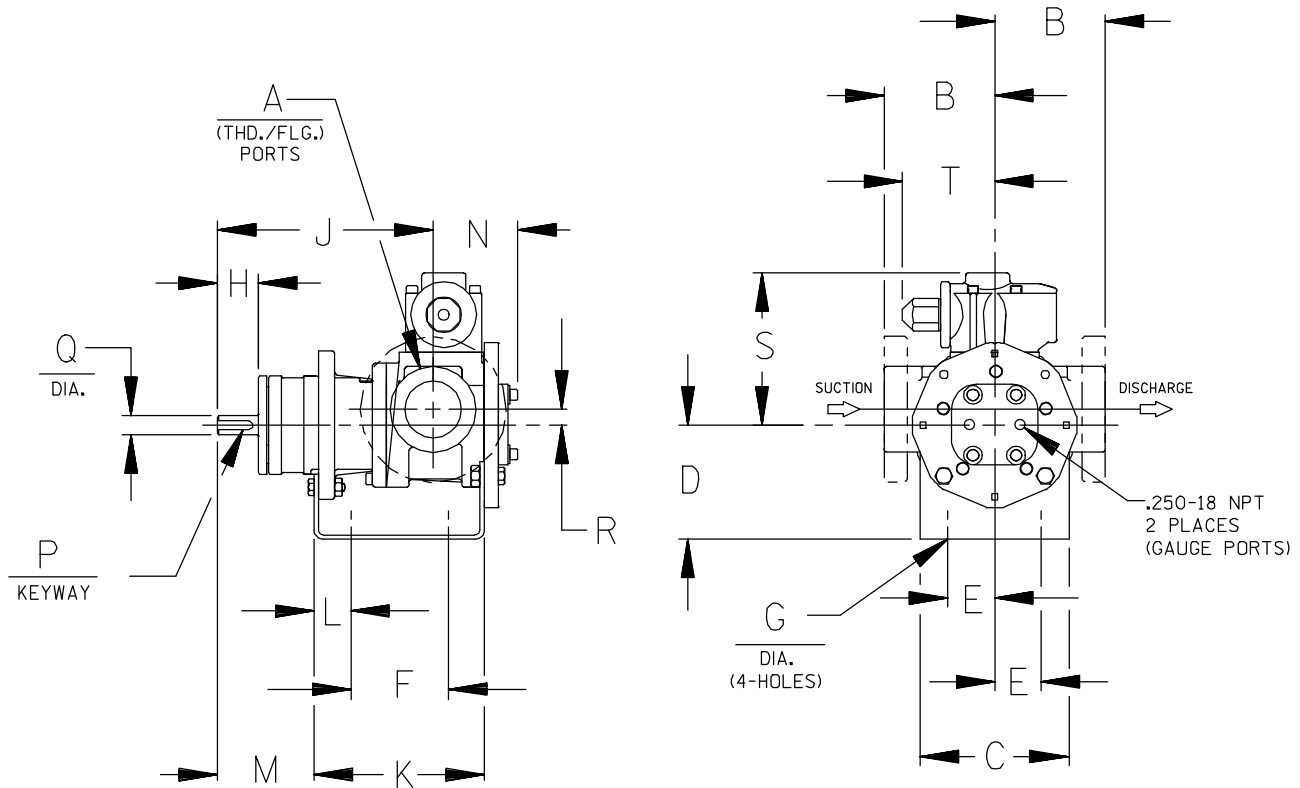

CAD FILE NO.: 16458D

| MODEL NUMBERS | PUMP DIMENSIONS - INCHES [MILLIMETERS] | | | | | | | | | | | | | | | | | |
|---------------|--|---|---------------|--|--------------|---------------|-------------|--------------|----------------|---------------|--------------|---------------|---------------|---------------------------------|--------------|--------------|---------------|---------------|
| | A | B | C | D | E | F | G | H | J | K | L | M | N | P | Q | R | S | T |
| GHC D | 1" | 4.00 † [102] | 4.00 [102] | 3.50* [89] 4.50 [114] 5.25 [133] | 1.62 [41] | 3.12 [79] | .41 [10] | 1.16 [30] | 6.19 [157] | 5.04 [128] | .76 [19] | 2.62 [66] | 2.74 [70] | .12 [3] x .75 [19] | .50 [13] | .62 [16] | 5.19 [132] | 3.58 [91] |
| GHC G | 1-1/2" | 4.00 † [102] | 5.88 [149] | 3.50* [89] 4.50 [114] 5.25 [133] 6.25 [159] | 1.62 [41] | 4.00 [102] | .41 [10] | 1.62 [41] | 8.50 [216] | 6.71 [170] | 1.06 [27] | 3.82 [97] | 3.35 [85] | .19 [5] x 1.25 [32] | .75 [19] | .62 [16] | 6.00 [152] | 3.62 [92] |
| GHC J | 3" | 6.00* [152] † 6.31 † [160] | 6.88 [175] | 4.50 [114] 5.25* [133] 6.25 [159] 7.00 [178] 8.00 [203] | 2.88 [73] | 4.25 [108] | .44 [11] | 2.50 [64] | 12.12 [308] | 9.75 [248] | 1.75 [44] | 5.50 [140] | 4.66 [118] | .25 [6] x 2.00 [51] | 1.00 [25] | 1.12 [28] | 9.06 [230] | 6.75 [171] |

* STANDARD DIMENSION
 PORTS ARE COMPATIBLE WITH 150# OR 300# ANSISTEEL FLANGES. ALL OTHER PORTS ARE TAPPED NPT
 † FOR ANSIPipe. OPTIONAL [DIN FLANGES OR TAPPED [BSP] PORTS AVAILABLE FOR EXPORT MARKET.
 NPT FOR ANSIPipe. OPTIONAL (DIN) FLANGES OR TAPPED (BSP) PORTS AVAILABLE FOR EXPORT MARKET.
 ‡ 90° HOUSING

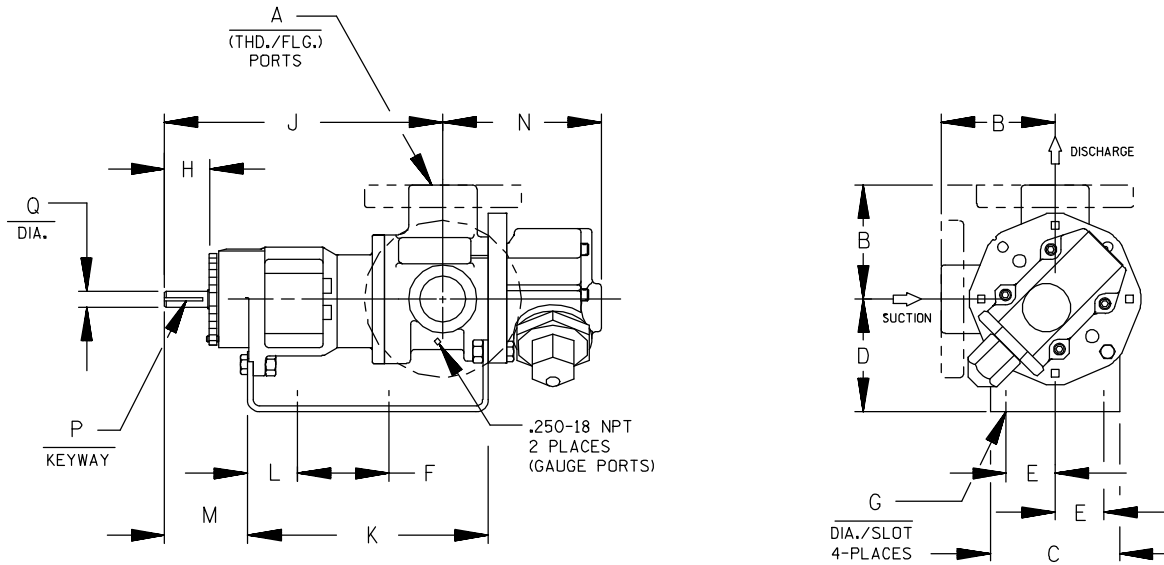

CAD FILE NO.: 16669F

| MODEL NUMBERS | PUMP DIMENSIONS - INCHES [MILLIMETERS] | | | | | | | | | | | | | | |
|---------------|--|----------------------------------|----------------|--|--------------|----------------|-------------|--------------|----------------|----------------|--------------|---------------|--------------------|----------------------------------|--------------|
| | A | B | C | D | E | F | G | H | J | K | L | M | N | P | Q |
| GHS G | 1-1/2" | 4.00 [102] | 4.88 [124] | 3.50* [89] 4.50 [114] 5.25 [133] 6.25 [159] | 1.62 [41] | 8.00 [203] | .41 [10] | 1.62 [41] | 12.06 [306] | 10.72 [272] | 1.52 [39] | 3.35 [85] | 5.70 [145] | .19 [5] x 1.25 [32] | .75 [19] |
| GHS J | 3" | 6.00 † [152] 6.31 [160] | 6.88 [175] | 5.25* [133] 6.25 [159] 7.00 [178] 8.00 [203] | 2.88 [73] | 10.00 [254] | .44 [11] | 2.50 [64] | 15.68 [398] | 14.31 [363] | 2.77 [70] | 4.48 [114] | 8.50 [216] | .25 [6] x 2.00 [51] | 1.00 [25] |
| GHS N | 2" | 5.25* [133] 5.38 [137] | 8.00 [203] | 4.50 [114] 5.25* [133] 6.25 [159] 7.00 [178] 8.00 [203] | 2.88 [73] | 10.00 [254] | .44 [11] | 2.58 [66] | 16.37 [416] | 15.14 [385] | 2.69 [68] | 4.56 [116] | 7.59 [193] | .25 [6] x 2.00 [51] | 1.12 [32] |
| | 3" | 7.19 [183] | | | | | | | | | | | 8.72 [221] * | | |
| GHS R | 2-1/2" | | | | | | | | | | | | | | |
| | 3" | 7.19 [183] | 10.50 [267] | 7.00 [178] | 3.75 [95] | 13.75 [349] | .52 [13] | 2.25 [57] | 17.87 [454] | 17.36 [441] | 1.80 [46] | 4.70 [119] | 11.31 [287] | .38 [10] x 1.88 [48] | 1.44 [37] |
| | 4" | | | | | | | | | | | | | | |

* STANDARD DIMENSION

† PORTS ARE COMPATIBLE WITH 150* OR 300* ANSISTEEL FLANGES. ALL OTHER PORTS ARE TAPPED NPT FOR ANSIPIPE. OPTIONAL (DIN) FLANGES OR TAPPED (BSP) PORTS AVAILABLE FOR EXPORT MARKET.

† 180° HOUSING

GHC/GHS

FOR GHC DRIVE OPTIONS

AND DIMENSIONS

SEE

SECTION 540

FOR GHS DRIVE OPTIONS

AND DIMENSIONS

SEE

SECTION 545

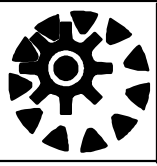

PERFORMANCE CURVES

SPEED VS. CAPACITY/HORSEPOWER

GF Hydraulic Size

SEC. 500

Page 44

January 2010

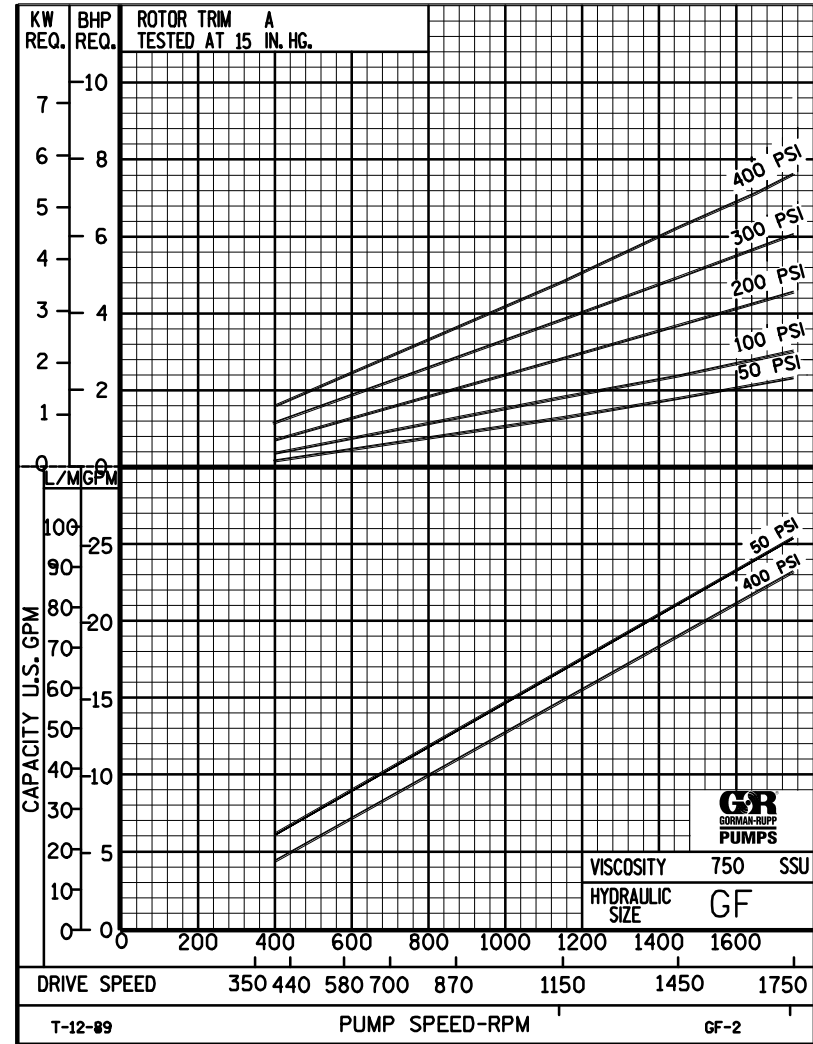
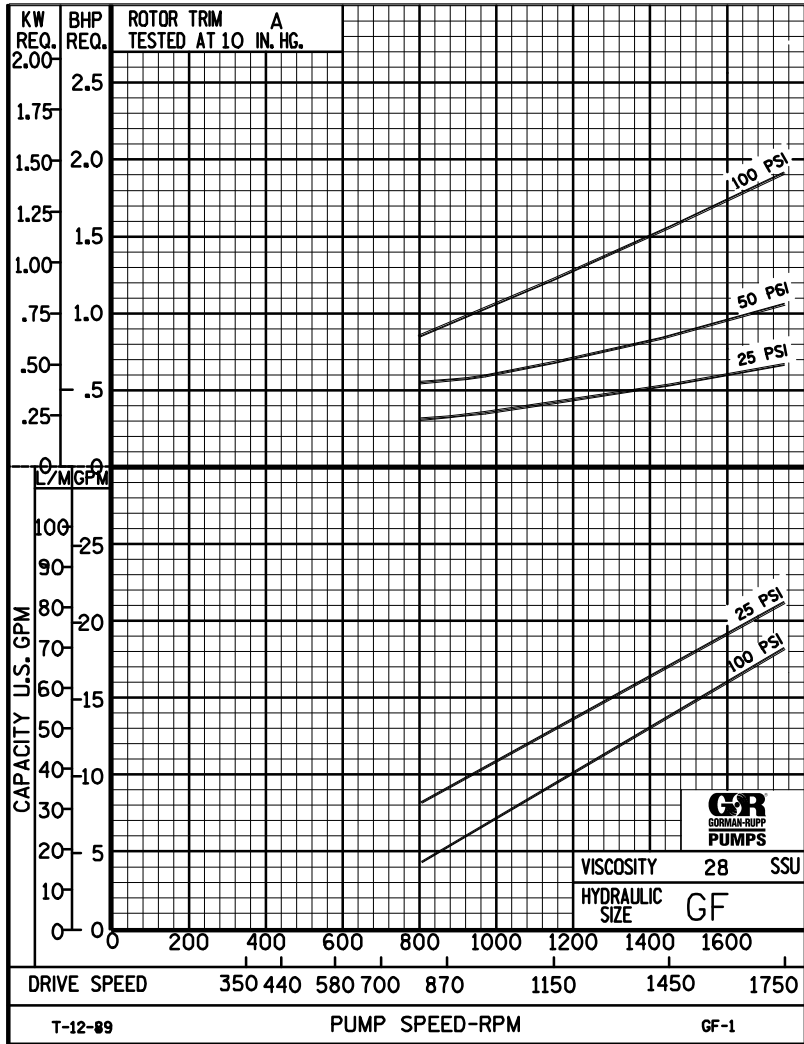

THE GORMAN-RUPP COMPANY • MANSFIELD, OHIO
 GORMAN-RUPP OF CANADA LIMITED • ST. THOMAS, ONTARIO, CANADA

Printed in U.S.A.

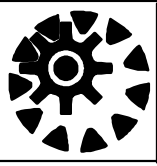

PERFORMANCE CURVES

SPEED VS. CAPACITY/HORSEPOWER

GF Hydraulic Size

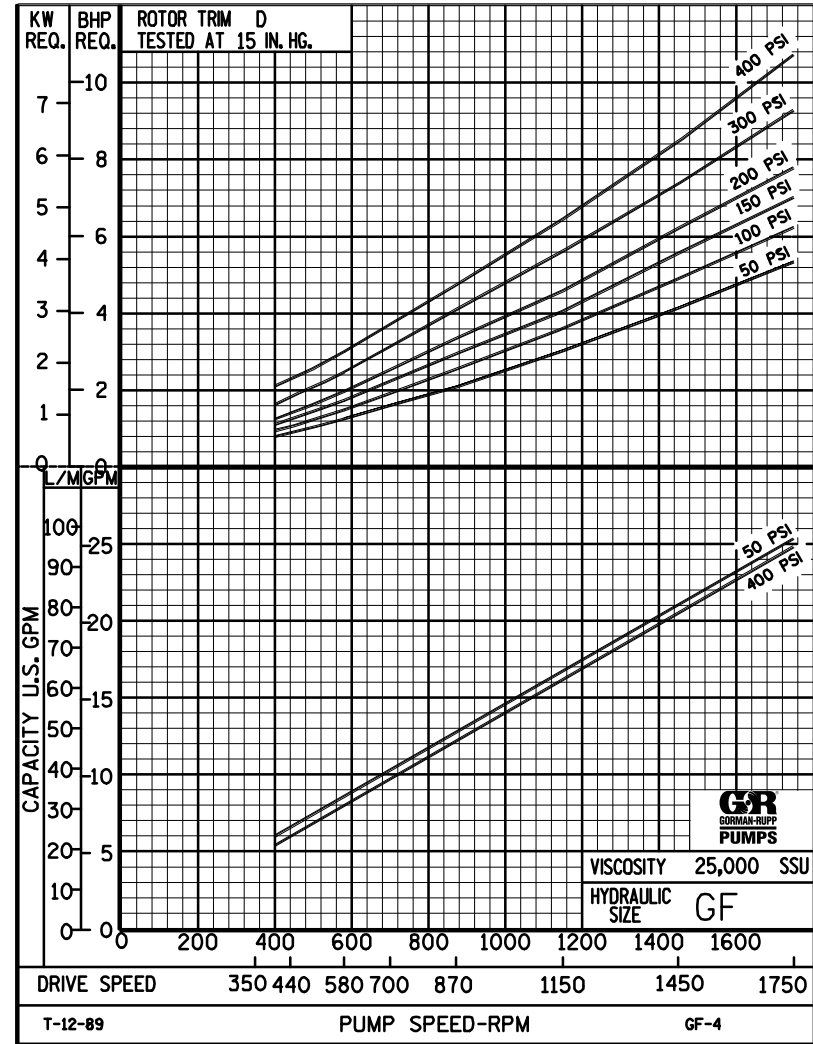
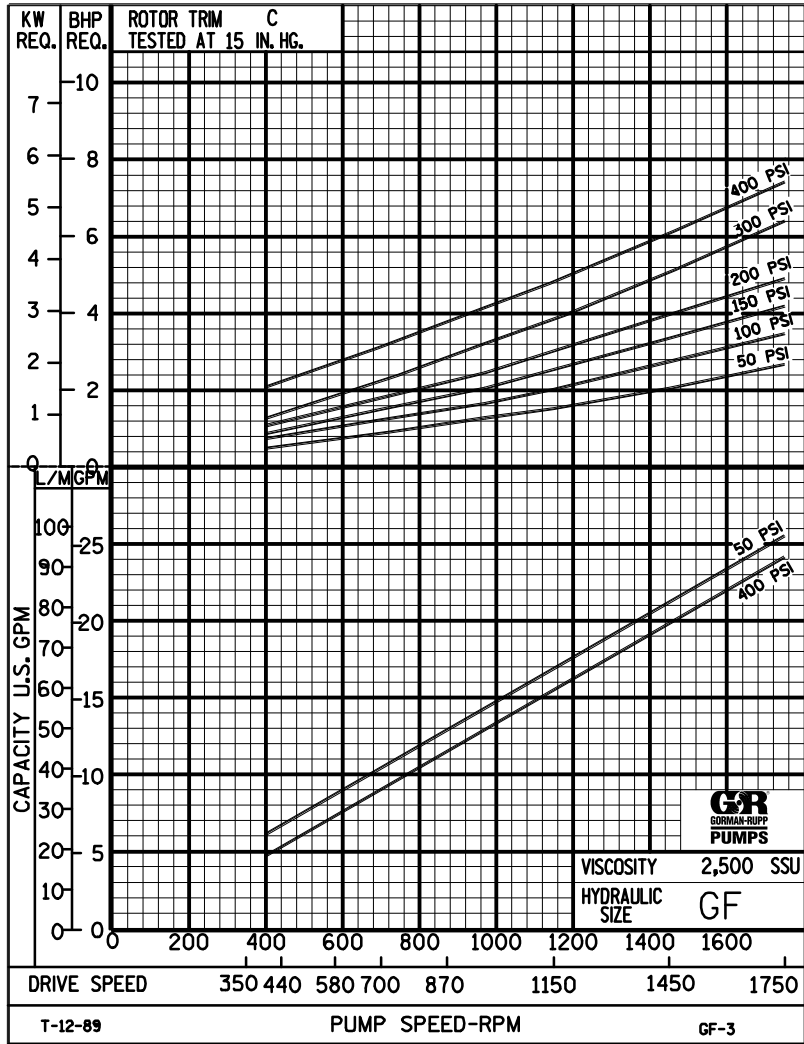

THE GORMAN-RUPP COMPANY • MANSFIELD, OHIO
 GORMAN-RUPP OF CANADA LIMITED • ST. THOMAS, ONTARIO, CANADA



GF

PUMP HYDRAULIC SIZE CHART

SEC. 500

Page 46

January 2010

**23 GPM
1750 RPM**

| NOMINAL | | ROTOR TRIM | VISCOSITY (SSU) | N.I.P.R. (PSIA) | FRICTION PIPE LOSS (PSI/FT) <small>(Based on Sch 40 Steel Pipe)</small> | | | | | FULL BYPASS RELIEF VALVE PRESSURE (PSI) | | | | | CAPACITY (GPM) / H.P. REQUIRED | | | | | | | | | | | | | | |
|----------|-----------|------------|-----------------|-----------------|--|------|--------|--------|-----|---|-----|-----|-------------|-----|--------------------------------|-----|-----|-----|-----------------|-----|-----|-----|-----|-----|-----|--|--|--|--|
| CAP. GPM | SPEED RPM | | | | PIPE DIAMETER | | | | | CRACKING PRESS. (PSI) | | | | | DIFFERENTIAL PRESSURE (PSI) | | | | | | | | | | | | | | |
| | | | | | 3/4" | 1" | 1 1/4" | 1 1/2" | 2" | LOW PRES R/V | | | HI PRES R/V | | MEDIUM DUTY AND HEAVY DUTY | | | | HEAVY DUTY ONLY | | | | | | | | | | |
| 23 | 1750 | STD | 28 | 3.9 | .01 | .01 | .01 | .01 | .01 | 63 | 89 | 117 | | | | 21 | 20 | 19 | 18 | | | | | | | | | | |
| | | | 32 | | .36 | .12 | .03 | .02 | .01 | | | | | | | .69 | 1.1 | 1.5 | 1.9 | | | | | | | | | | |
| | | | 38 | 3.9 | .46 | .15 | .04 | .02 | .01 | 63 | 89 | 117 | 167 | | | | 22 | 21 | 21 | 19 | 18 | | | | | | | | |
| | | | 50 | | .56 | .18 | .05 | .03 | .01 | | | | | | | | .92 | 1.1 | 1.7 | 2.1 | 2.9 | | | | | | | | |
| | | | 70 | 3.9 | .63 | .20 | .06 | .03 | .01 | 64 | 90 | 119 | 167 | 230 | | | | 23 | 23 | 22 | 21 | 20 | 20 | | | | | | |
| | | | 100 | | .74 | .24 | .07 | .03 | .01 | | | | | | | | | 1.1 | 1.4 | 1.8 | 2.2 | 3.1 | 3.8 | | | | | | |
| | | | 150 | 3.9 | .83 | .27 | .08 | .04 | .01 | 64 | 90 | 119 | 167 | 230 | | | | 24 | 24 | 23 | 22 | 22 | 22 | 21 | 19 | | | | |
| | | | 200 | | .87 | .31 | .10 | .05 | .02 | | | | | | | | | 1.4 | 1.6 | 2.1 | 2.4 | 3.2 | 3.9 | 5.3 | 6.6 | | | | |
| | | | 300 | 3.9 | .90 | .34 | .12 | .06 | .03 | 65 | 91 | 123 | 167 | 230 | | | | 25 | 24 | 24 | 23 | 23 | 23 | 22 | 21 | | | | |
| | | | 500 | | 1.47 | .56 | .19 | .10 | .04 | | | | | | | | | 1.6 | 1.9 | 2.4 | 2.7 | 3.4 | 4.2 | 5.6 | 6.9 | | | | |
| | | 750 | 3.9 | 2.20 | .84 | .28 | .15 | .06 | 65 | 91 | 123 | 167 | 230 | | | | 25 | 25 | 25 | 24 | 24 | 24 | 24 | 23 | | | | | |
| | | 1,000 | | 2.94 | 1.12 | .38 | .20 | .08 | | | | | | | | | 1.8 | 2.2 | 2.7 | 3.0 | 3.7 | 4.4 | 5.8 | 7.1 | | | | | |
| | | 2,000 | 5.0 | 5.87 | 2.24 | .75 | .40 | .15 | 69 | 97 | 124 | 168 | 232 | | | | 25 | 25 | 25 | 25 | 25 | 24 | 24 | 24 | | | | | |
| | | 3,500 | | 10.3 | 3.91 | 1.31 | .71 | .26 | | | | | | | | | 2.4 | 2.9 | 3.6 | 3.7 | 4.4 | 4.9 | 6.4 | 7.6 | | | | | |
| | | 5,000 | 5.8 | 14.7 | 5.59 | 1.87 | 1.01 | .37 | 74 | 100 | 127 | 170 | 233 | | | | 25 | 25 | 25 | 25 | 25 | 25 | 24 | 24 | | | | | |
| | | 7,500 | | 22.0 | 8.40 | 2.80 | 1.51 | .56 | | | | | | | | | 3.1 | 3.4 | 4.1 | 4.4 | 5.1 | 5.8 | 7.3 | 8.3 | | | | | |
| | | 10,000 | 6.5 | 29.4 | 11.2 | 3.73 | 2.01 | .74 | 79 | 104 | 130 | 172 | 233 | | | | 25 | 25 | 25 | 25 | 25 | 25 | 25 | 24 | | | | | |
| | | 15,000 | | 44.0 | 16.8 | 5.60 | 3.02 | 1.11 | | | | | | | | | 3.7 | 4.1 | 4.6 | 5.2 | 5.9 | 6.6 | 8.2 | 9.3 | | | | | |
| | | 20,000 | 7.1 | 58.7 | 22.4 | 7.46 | 4.03 | 1.48 | 84 | 109 | 134 | 175 | 234 | | | | 25 | 25 | 25 | 25 | 25 | 25 | 25 | 24 | | | | | |
| | | 25,000 | | 73.4 | 28.0 | 9.32 | 5.03 | 1.85 | | | | | | | | | 4.2 | 4.6 | 5.5 | 6.2 | 7.0 | 7.8 | 9.3 | 11 | | | | | |
| 50,000 | | | | | | | | | | | | | | | | | | | | | | | | | | | | | |
| 75,000 | | | | | | | | | | | | | | | | | | | | | | | | | | | | | |
| 100,000 | | | | | | | | | | | | | | | | | | | | | | | | | | | | | |
| 150,000 | | | | | | | | | | | | | | | | | | | | | | | | | | | | | |
| 200,000 | | | | | | | | | | | | | | | | | | | | | | | | | | | | | |
| 250,000 | | | | | | | | | | | | | | | | | | | | | | | | | | | | | |

(NOTE) For speeds not shown on the pump hydraulic charts, consult factory.



GF

PUMP HYDRAULIC SIZE CHART

SEC. 500

Page 47

January 2010

**15 GPM
1150 RPM**

| NOMINAL | | ROTOR TRIM | VISCOSITY (SSU) | N.I.P.R. (PSIA) | FRICTION PIPE LOSS (PSI/FT) <small>(Based on Sch 40 Steel Pipe)</small> | | | | | FULL BYPASS RELIEF VALVE PRESSURE (PSI) | | | | | CAPACITY (GPM) / H.P. REQUIRED | | | | | | | | | | | |
|----------|-----------|------------|-----------------|-----------------|--|------|--------------|------|-----|---|-----|----------------------------|-----|-----|--------------------------------|-----------------|-----|-----|-----|-----|-----|-----|-----|-----|----|--|
| CAP. GPM | SPEED RPM | | | | PIPE DIAMETER | | | | | CRACKING PRESS. (PSI) | | | | | DIFFERENTIAL PRESSURE (PSI) | | | | | | | | | | | |
| | | 3/4" | 1" | 1 1/4" | 1 1/2" | 2" | LOW PRES R/V | | | | | MEDIUM DUTY AND HEAVY DUTY | | | | HEAVY DUTY ONLY | | | | | | | | | | |
| | | | | | | | 50 | 75 | 100 | 150 | 200 | 25 | 50 | 75 | 100 | 150 | 200 | 300 | 400 | | | | | | | |
| 15 | 1150 | STD | 28 | 2.2 | .01 | .01 | .01 | .01 | .01 | 59 | 86 | 111 | | | | 13 | 11 | 10 | 9.5 | | | | | | | |
| | | | 32 | | .17 | .06 | .02 | .01 | .01 | | | | | | | .56 | .72 | .96 | 1.2 | | | | | | | |
| | | | 38 | 2.2 | .22 | .07 | .02 | .01 | .01 | 59 | 86 | 111 | 161 | | | | 13 | 13 | 11 | 11 | 9.5 | | | | | |
| | | | 50 | | .27 | .09 | .03 | .01 | .01 | | | | | | | | .62 | .78 | 1.0 | 1.3 | 1.8 | | | | | |
| | | | 70 | 2.2 | .30 | .10 | .03 | .01 | .01 | 60 | 87 | 113 | 163 | 215 | | | 14 | 14 | 13 | 12 | 12 | 11 | | | | |
| | | | 100 | | .36 | .12 | .03 | .02 | .01 | | | | | | | | .66 | .83 | 1.1 | 1.4 | 1.9 | 2.4 | | | | |
| | | | 150 | 2.2 | .41 | .14 | .05 | .02 | .01 | 60 | 87 | 113 | 163 | 217 | | | 15 | 15 | 14 | 14 | 13 | 13 | 13 | 13 | 12 | |
| | | | 200 | | .46 | .18 | .06 | .03 | .01 | | | | | | | | .78 | .98 | 1.2 | 1.5 | 1.9 | 2.4 | 3.5 | 4.6 | | |
| | | | 300 | 2.2 | .58 | .22 | .08 | .04 | .02 | 60 | 87 | 115 | 165 | 219 | | | 16 | 15 | 15 | 15 | 15 | 14 | 14 | 13 | | |
| | | | 500 | | .96 | .37 | .12 | .07 | .03 | | | | | | | | .94 | 1.2 | 1.4 | 1.6 | 2.1 | 2.6 | 3.6 | 4.7 | | |
| | | 750 | 2.2 | 1.44 | .55 | .18 | .10 | .04 | 60 | 87 | 115 | 165 | 222 | | | 16 | 16 | 16 | 16 | 16 | 15 | 15 | 14 | | | |
| | | 1,000 | | 1.92 | .73 | .25 | .13 | .05 | | | | | | | | 1.1 | 1.3 | 1.5 | 1.7 | 2.2 | 2.7 | 3.7 | 4.8 | | | |
| | | 2,000 | 2.8 | 3.83 | 1.46 | .49 | .26 | .10 | 62 | 90 | 115 | 165 | 222 | | | 17 | 17 | 16 | 16 | 16 | 16 | 15 | 15 | | | |
| | | 3,500 | | 6.70 | 2.55 | .85 | .46 | .17 | | | | | | | | 1.4 | 1.8 | 2.0 | 2.1 | 2.6 | 3.1 | 4.1 | 5.1 | | | |
| | | 5,000 | 3.2 | 9.57 | 3.64 | 1.22 | .66 | .24 | 65 | 92 | 117 | 167 | 224 | | | 17 | 17 | 16 | 16 | 16 | 16 | 16 | 16 | | | |
| | | 7,500 | | 14.4 | 5.46 | 1.83 | .99 | .36 | | | | | | | | 1.6 | 2.0 | 2.2 | 2.4 | 2.9 | 3.5 | 4.4 | 5.4 | | | |
| | | 10,000 | 3.6 | 19.1 | 7.29 | 2.43 | 1.31 | .49 | 68 | 94 | 119 | 169 | 224 | | | 17 | 17 | 16 | 16 | 16 | 16 | 16 | 16 | | | |
| | | 15,000 | | 28.7 | 10.9 | 3.65 | 1.97 | .73 | | | | | | | | 1.9 | 2.4 | 2.7 | 3.0 | 3.5 | 4.0 | 4.8 | 5.9 | | | |
| | | 20,000 | 3.9 | 38.3 | 14.6 | 4.87 | 2.63 | .97 | 72 | 97 | 122 | 172 | 224 | | | 17 | 17 | 16 | 16 | 16 | 16 | 16 | 16 | | | |
| | | 25,000 | | 47.8 | 18.2 | 6.08 | 3.28 | 1.21 | | | | | | | | 2.2 | 2.8 | 3.2 | 3.5 | 4.0 | 4.5 | 5.3 | 6.5 | | | |
| | | 50,000 | 6.1 | 95.7 | 36.4 | 12.2 | 6.56 | 2.42 | 77 | 102 | 127 | 177 | 229 | | | 17 | 16 | 16 | 16 | 16 | 16 | 16 | 16 | | | |
| 75,000 | 144 | 54.6 | | 18.3 | 9.85 | 3.63 | 3.6 | 4.5 | | | | | | | | 5.1 | 5.7 | 6.3 | 6.8 | 7.7 | 8.8 | | | | | |
| 100,000 | | | | | | | | | | | | | | | | | | | | | | | | | | |
| 150,000 | | | | | | | | | | | | | | | | | | | | | | | | | | |
| 200,000 | | | | | | | | | | | | | | | | | | | | | | | | | | |
| 250,000 | | | | | | | | | | | | | | | | | | | | | | | | | | |

(NOTE) For speeds not shown on the pump hydraulic charts, consult factory.

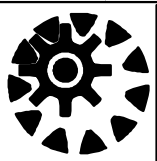

GF

PUMP HYDRAULIC SIZE CHART

SEC. 500

Page 48

January 2010

**11 GPM
870 RPM**

| NOMINAL | | ROTOR TRIM | VISCOSITY (SSU) | N.I.P.R. (PSIA) | FRICTION PIPE LOSS (PSI/FT) <small>(Based on Sch 40 Steel Pipe)</small> | | | | | FULL BYPASS RELIEF VALVE PRESSURE (PSI) | | | | | CAPACITY (GPM) / H.P. REQUIRED | | | | | | | | | | | | | |
|----------|-----------|------------|-----------------|-----------------|--|------|--------------|------|-------------|---|-----|----------------------------|-----|-----|--------------------------------|-----------------|-----|-----|-----|-----|-----|-----|-----|-----|-----|--|--|--|
| CAP. GPM | SPEED RPM | | | | PIPE DIAMETER | | | | | CRACKING PRESS. (PSI) | | | | | DIFFERENTIAL PRESSURE (PSI) | | | | | | | | | | | | | |
| | | 3/4" | 1" | 1 1/4" | 1 1/2" | 2" | LOW PRES R/V | | HI PRES R/V | | | MEDIUM DUTY AND HEAVY DUTY | | | | HEAVY DUTY ONLY | | | | | | | | | | | | |
| | | | | | | | | | | | | | | | | | | | | | | | | | | | | |
| 11 | 870 | STD | 28 | 1.5 | .01 | .01 | .01 | .01 | .01 | 57 | 82 | 107 | | | 9 | 8 | 7 | 6 | | | | | | | | | | |
| | | | 32 | | .10 | .03 | .01 | .01 | .01 | | | | | | | .32 | .53 | .71 | .91 | | | | | | | | | |
| | | | 38 | 1.5 | .13 | .04 | .01 | .01 | .01 | 57 | 82 | 107 | 158 | | | 10 | 9 | 8 | 7.5 | 6.5 | | | | | | | | |
| | | | 50 | | .16 | .05 | .02 | .01 | .01 | | | | | | | .50 | .59 | .85 | 1.1 | 1.4 | | | | | | | | |
| | | | 70 | 1.5 | .18 | .06 | .02 | .01 | .01 | 57 | 82 | 108 | 159 | 210 | | | 10 | 10 | 9.5 | 9 | 8 | 7 | | | | | | |
| | | | 100 | | .21 | .06 | .02 | .01 | .01 | | | | | | | .54 | .63 | .88 | 1.1 | 1.5 | 1.8 | | | | | | | |
| | | | 150 | 1.5 | .26 | .09 | .03 | .01 | .01 | 58 | 83 | 109 | 159 | 212 | | | 11 | 11 | 10 | 10 | 10 | 9.5 | 9.5 | 8 | | | | |
| | | | 200 | | .33 | .12 | .05 | .02 | .01 | | | | | | | .61 | .71 | .94 | 1.2 | 1.5 | 1.8 | 2.5 | 3.3 | | | | | |
| | | | 300 | 1.5 | .43 | .16 | .06 | .03 | .01 | 58 | 83 | 110 | 160 | 213 | | | 12 | 12 | 11 | 11 | 11 | 10 | 10 | 9.5 | | | | |
| | | | 500 | | .70 | .27 | .09 | .05 | .02 | | | | | | | .69 | .81 | 1.0 | 1.3 | 1.6 | 1.9 | 2.5 | 3.5 | | | | | |
| | | 750 | 1.5 | 1.05 | .40 | .14 | .07 | .03 | 58 | 83 | 112 | 162 | 215 | | | 12 | 12 | 12 | 12 | 12 | 11 | 11 | 11 | | | | | |
| | | 1,000 | | 1.41 | .54 | .18 | .10 | .04 | | | | | | | .79 | .93 | 1.1 | 1.3 | 1.7 | 2.0 | 2.6 | 3.6 | | | | | | |
| | | | | "C" | 2,000 | 2.0 | 2.81 | 1.07 | .36 | .19 | .07 | 59 | 86 | 113 | 163 | 215 | 13 | 12 | 12 | 12 | 12 | 12 | 11 | 11 | | | | |
| | | | | | 3,500 | | 4.91 | 1.87 | .63 | .34 | .13 | | | | | | | .98 | 1.2 | 1.3 | 1.5 | 1.8 | 2.2 | 2.8 | 3.7 | | | |
| | | | | | 5,000 | 2.4 | 7.02 | 2.67 | .89 | .48 | .18 | 61 | 86 | 113 | 163 | 215 | 13 | 12 | 12 | 12 | 12 | 12 | 12 | 12 | 11 | | | |
| | | | | | 7,500 | | 10.5 | 4.00 | 1.34 | .72 | .27 | | | | | | | 1.3 | 1.5 | 1.7 | 1.9 | 2.2 | 2.6 | 3.2 | 4.1 | | | |
| | | | | | 10,000 | 2.7 | 14.0 | 5.34 | 1.78 | .96 | .36 | 64 | 89 | 115 | 167 | 217 | 13 | 12 | 12 | 12 | 12 | 12 | 12 | 12 | 12 | | | |
| | | | | | 15,000 | | 21.1 | 8.01 | 2.68 | 1.45 | .53 | | | | | | | 1.5 | 1.8 | 2.1 | 2.3 | 2.6 | 2.9 | 3.6 | 4.4 | | | |
| | | | | 20,000 | 3.0 | 28.1 | 10.7 | 3.57 | 1.93 | .71 | 67 | 92 | 117 | 169 | 219 | 13 | 12 | 12 | 12 | 12 | 12 | 12 | 12 | 12 | | | | |
| | | | | 25,000 | | 35.1 | 13.4 | 4.46 | 2.41 | .89 | | | | | | | 1.9 | 2.2 | 2.4 | 2.5 | 2.9 | 3.3 | 4.1 | 4.8 | | | | |
| | | 50,000 | 4.9 | 70.2 | 26.7 | 8.92 | 4.81 | 1.77 | 70 | 95 | 123 | 173 | 225 | 13 | 12 | 12 | 12 | 12 | 12 | 12 | 12 | 12 | | | | | | |
| | | 75,000 | | 105 | 40.1 | 13.4 | 7.22 | 2.66 | | | | | | | 2.9 | 3.4 | 3.6 | 3.8 | 4.2 | 4.6 | 5.4 | 6.1 | | | | | | |
| | | 100,000 | 7.1 | 140 | 53.4 | 17.9 | 9.63 | 3.55 | 74 | 99 | 127 | 177 | 231 | 12 | 12 | 12 | 12 | 12 | 12 | 12 | 12 | 12 | | | | | | |
| | | 150,000 | | 211 | 80.1 | 26.8 | 14.5 | 5.32 | | | | | | | 3.6 | 4.3 | 4.5 | 4.7 | 5.1 | 5.4 | 6.2 | 6.9 | | | | | | |
| | | 200,000 | | | | | | | | | | | | | | | | | | | | | | | | | | |
| | | 250,000 | | | | | | | | | | | | | | | | | | | | | | | | | | |

(NOTE) For speeds not shown on the pump hydraulic charts, consult factory.



GF

PUMP HYDRAULIC SIZE CHART

SEC. 500

Page 49

January 2010

**8 GPM
580 RPM**

| NOMINAL | | ROTOR TRIM | VISCOSITY (SSU) | N.I.P.R. (PSIA) | FRICTION PIPE LOSS (PSI/FT) <small>(Based on Sch 40 Steel Pipe)</small> | | | | | FULL BYPASS RELIEF VALVE PRESSURE (PSI) | | | | | CAPACITY (GPM) / H.P. REQUIRED | | | | | | | | | | | | | |
|----------|-----------|------------|-----------------|-----------------|--|-----|--------|--------|------|---|------|-----|-------------|-----|--------------------------------|-----|-----|-----|-----|-----|-----|-----|-----|-----|-----|--|--|--|
| CAP. GPM | SPEED RPM | | | | PIPE DIAMETER | | | | | CRACKING PRESS. (PSI) | | | | | DIFFERENTIAL PRESSURE (PSI) | | | | | | | | | | | | | |
| | | | | | 3/4" | 1" | 1 1/4" | 1 1/2" | 2" | LOW PRES R/V | | | HI PRES R/V | | 25 | 50 | 75 | 100 | 150 | 200 | 300 | 400 | | | | | | |
| 8 | 580 | STD | 28 | 1.1 | .01 | .01 | .01 | .01 | .01 | 56 | 81 | 106 | | | 6 | 5 | 4.5 | 4 | | | | | | | | | | |
| | | | 32 | | .06 | .02 | .01 | .01 | .01 | | | | | | | .21 | .35 | .47 | .61 | | | | | | | | | |
| | | | 38 | 1.1 | .07 | .03 | .01 | .01 | .01 | 56 | 81 | 106 | 157 | | | 6.5 | 6 | 5.5 | 4.5 | 4 | | | | | | | | |
| | | | 50 | | .09 | .03 | .01 | .01 | .01 | | | | | | | .34 | .40 | .57 | .74 | .92 | | | | | | | | |
| | | | 70 | 1.1 | .10 | .04 | .01 | .01 | .01 | 56 | 81 | 107 | 158 | 209 | | 7 | 6.5 | 6 | 6 | 5.5 | 4.5 | | | | | | | |
| | | | 100 | | .10 | .04 | .01 | .01 | .01 | | | | | | | .36 | .42 | .59 | .76 | .98 | 1.2 | | | | | | | |
| | | | 150 | 1.1 | .15 | .05 | .02 | .01 | .01 | 57 | 82 | 108 | 158 | 211 | | 7.5 | 7.5 | 7 | 6.5 | 6.5 | 6 | 6 | 6 | 5 | | | | |
| | | | 200 | | .24 | .08 | .03 | .02 | .01 | | | | | | | .41 | .48 | .63 | .78 | 1.0 | 1.2 | 1.7 | 2.2 | | | | | |
| | | | 300 | 1.1 | .31 | .12 | .04 | .02 | .01 | 57 | 82 | 109 | 159 | 212 | | 8 | 8 | 7.5 | 7 | 7 | 7 | 6.5 | 6 | | | | | |
| | | | 500 | | .51 | .19 | .07 | .04 | .01 | | | | | | | .46 | .54 | .69 | .84 | 1.1 | 1.3 | 1.7 | 2.3 | | | | | |
| | | 750 | 1.1 | .77 | .29 | .10 | .05 | .02 | 57 | 82 | 111 | 161 | 214 | | 8.5 | 8 | 8 | 8 | 8 | 7 | 7.5 | 7 | | | | | | |
| | | 1,000 | | 1.02 | .39 | .14 | .07 | .03 | | | | | | | .53 | .62 | .76 | .89 | 1.1 | 1.4 | 1.7 | 2.4 | | | | | | |
| | | | | "C" | 2,000 | 1.5 | 2.04 | .78 | .26 | .14 | .05 | 58 | 85 | 112 | 162 | 214 | 8.5 | 8.5 | 8 | 8 | 8 | 8 | 7.5 | 7.5 | | | | |
| | | | | | 3,500 | | 3.57 | 1.36 | .46 | .25 | .09 | | | | | | .66 | .77 | .88 | .99 | 1.2 | 1.5 | 1.9 | 2.5 | | | | |
| | | | | | 5,000 | 1.9 | 5.01 | 1.94 | .65 | .35 | .13 | 60 | 85 | 112 | 162 | 214 | 8.5 | 8.5 | 8 | 8 | 8 | 8 | 8 | 7.5 | 7.5 | | | |
| | | | | | 7,500 | | 7.65 | 2.91 | .97 | .53 | .19 | | | | | | .84 | .99 | 1.1 | 1.3 | 1.5 | 1.7 | 2.1 | 2.7 | | | | |
| | | | | | 10,000 | 2.2 | 10.2 | 3.88 | 1.30 | .70 | .26 | 63 | 88 | 114 | 166 | 216 | 8.5 | 8.5 | 8 | 8 | 8 | 8 | 8 | 7.5 | 7.5 | | | |
| | | | | | 15,000 | | 15.3 | 5.83 | 1.95 | 1.05 | .39 | | | | | | 1.0 | 1.2 | 1.3 | 1.4 | 1.6 | 1.9 | 2.4 | 2.9 | | | | |
| | | | | "D" | 20,000 | 2.5 | 20.4 | 7.77 | 2.59 | 1.40 | .52 | 66 | 91 | 116 | 168 | 218 | 8.5 | 8.5 | 8 | 8 | 8 | 8 | 8 | 8 | 8 | | | |
| | | | | | 25,000 | | 25.5 | 9.71 | 3.24 | 1.75 | .65 | | | | | | 1.0 | 1.2 | 1.4 | 1.5 | 1.7 | 2.0 | 2.5 | 3.0 | | | | |
| | | | | | 50,000 | 4.0 | 51.1 | 19.4 | 6.50 | 3.50 | 1.29 | 68 | 93 | 120 | 170 | 222 | 8.5 | 8.5 | 8 | 8 | 8 | 8 | 8 | 8 | 8 | | | |
| | | | | | 75,000 | | 76.5 | 29.1 | 9.73 | 5.25 | 1.93 | | | | | | 1.6 | 1.9 | 2.1 | 2.2 | 2.4 | 2.7 | 3.2 | 3.7 | | | | |
| | | | | | 100,000 | 6.0 | 102 | 38.9 | 13.0 | 7.00 | 2.58 | 70 | 95 | 122 | 172 | 224 | 8.5 | 8 | 8 | 8 | 8 | 8 | 8 | 8 | 8 | | | |
| | | | | | 150,000 | | 153 | 58.3 | 19.5 | 10.5 | 3.87 | | | | | | 2.1 | 2.5 | 2.6 | 2.7 | 3.0 | 3.2 | 3.7 | 4.2 | | | | |
| | | | | | 200,000 | 9.4 | 204 | 77.7 | 26.0 | 14.0 | 5.15 | 76 | 101 | 130 | 180 | 236 | 8.5 | 8.5 | 8.5 | 8.5 | 8 | 8 | 8 | 8 | 8 | | | |
| | | 250,000 | - | | - | | - | - | - | | | | | | 2.5 | 3.0 | 3.1 | 3.2 | 3.4 | 3.7 | 4.2 | 4.7 | | | | | | |

(NOTE) For speeds not shown on the pump hydraulic charts, consult factory.



GF

SEC. 500

PAGE 49.1

February 2025

3 GPM
200 RPM

| NOMINAL | | VISCOSITY | | N.I.P.R. | FRICTION PIPE LOSS (PSI/FT) <small>(Schedule 40 Steel Pipe)</small> | | | | | CAPACITY (GPM) | | | | H.P. REQUIRED | | | | | | | |
|----------|------------|------------|---------|----------|---|-----|------|-----|-----|-----------------------------|-----|-----|-----|------------------|-----|-----|-----|--|--|--|--|
| GPM | RPM | ROTOR TRIM | (SSU) | (PSIa) | PIPE DIAMETER | | | | | MEDIUM-DUTY & HEAVY-DUTY | | | | HEAVY-DUTY ONLY | | | | | | | |
| | | | | | 1½" | 2" | 2½" | 3" | 4" | DIFFERENTIAL PRESSURE (PSI) | | | | 150 | 200 | 300 | 400 | | | | |
| | | | | | | 25 | 50 | 75 | 100 | 150 | 200 | 300 | 400 | | | | | | | | |
| 3 | 200 | STD | | | | | | | | | | | | | | | | | | | |
| | | | | | | | | | | | | | | | | | | | | | |
| | | | | | | | | | | | | | | | | | | | | | |
| | | | | | | | | | | | | | | | | | | | | | |
| | | | | | | | | | | | | | | | | | | | | | |
| | | | | | | | | | | | | | | | | | | | | | |
| | | | | | | | | | | | | | | | | | | | | | |
| | | | | | | | | | | | | | | | | | | | | | |
| | | | | "D" | | | | | | | | | | | | | | | | | |
| | | | | | | | | | | | | | | | | | | | | | |
| | | | | | | | | | | | | | | | | | | | | | |
| | | | | | | | | | | | | | | | | | | | | | |
| | | | | | | | | | | | | | | | | | | | | | |
| | | | | | | | | | | | | | | | | | | | | | |
| | | | | | | | | | | | | | | | | | | | | | |
| | | | | | | | | | | | | | | | | | | | | | |
| | | | 200,000 | 2.3 | 5.3 | 1.9 | 0.95 | 0.4 | 0.1 | 2.8 | 2.8 | 2.8 | 2.8 | 2.8 | 2.8 | 2.7 | 2.7 | | | | |
| | | | 399,999 | | 10.5 | 3.9 | 1.9 | 0.8 | 0.3 | 0.8 | 0.9 | 0.9 | 1.0 | 1.1 | 1.2 | 1.3 | 1.4 | | | | |
| | | | 400,000 | 2.6 | | | | | | 2.8 | 2.8 | 2.8 | 2.8 | 2.8 | 2.8 | 2.7 | 2.7 | | | | |
| | | | 599,999 | | 15.8 | 5.8 | 2.9 | 1.2 | 0.4 | 1.0 | 1.0 | 1.0 | 1.1 | 1.2 | 1.3 | 1.4 | 1.5 | | | | |
| | | | 600,000 | 3.2 | | | | | | 2.8 | 2.8 | 2.8 | 2.8 | 2.8 | 2.8 | 2.7 | 2.7 | | | | |
| | | | 799,999 | | 21 | 7.7 | 3.8 | 1.6 | 0.5 | 1.1 | 1.1 | 1.1 | 1.2 | 1.3 | 1.4 | 1.5 | 1.6 | | | | |
| | | | 800,000 | 3.5 | | | | | | 2.8 | 2.8 | 2.8 | 2.8 | 2.8 | 2.8 | 2.7 | 2.7 | | | | |
| | | | 1M | | NR | 9.7 | 4.75 | 2 | 0.7 | 1.2 | 1.2 | 1.2 | 1.3 | 1.4 | 1.5 | 1.6 | 1.7 | | | | |

(NOTE) For speeds not shown on the pump hydraulic charts, consult factory.