

**GHC SERIES  
 HEAVY DUTY COMPACT  
 STEEL ROTARY GEAR PUMP**

This heavy duty series pump is ideal for refining, petrochemical and applications requiring extra strength or shock resistance. The steel construction conforms to ASTM designation A216 Grade WCB. Superior rotor shaft support and an integral, maintenance-free radial/thrust bearing, reduce deflection and wear.

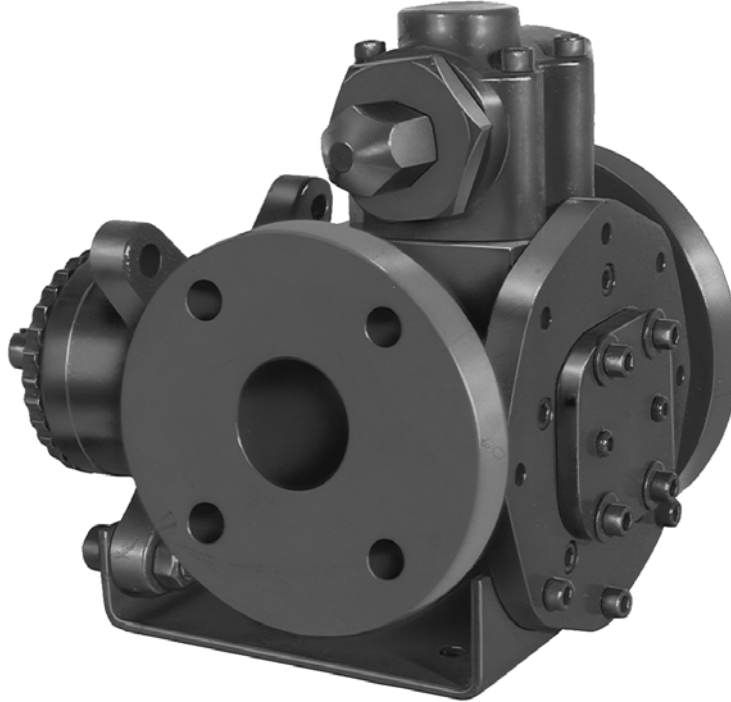

The GHC steel series is designed for applications in the operating ranges noted on the model pages. These units are available with head jackets for temperature control, carbon graphite bushings for low viscosity liquids, silicon carbide bushings for wear resistance, and numerous shaft seal options described on the following pages. These units may be foot mounted or, by using a motor adaptor, direct connected to NEMA "C" flange motors.

**FEATURES**

- 400 PSI CAPABILITY
- BALL BEARING THRUST CONTROL
- ROTOR END CLEARANCE EXTERNALLY ADJUSTABLE
- HIGH STRENGTH, COMPUTER PROFILED GEARING FOR QUIET OPERATION
- MULTIPLE PORT POSITIONS
- INTERNAL SEAL VENT

**OPERATING RANGE**

CAPACITY	(GPM) :	(3 TO 107)
	[LPM] :	[11 TO 405]
PRESSURE	(PSI) :	[0 TO 300]
	[BAR] :	[0 TO 21]
VISCOSITY	(SSU) :	(28 TO 25,000)
	[cSt] :	[1 TO 5417]
TEMPERATURE	(F) :	(-20° TO 350°)
	[C] :	[-29° TO 177°]

**APPLICATIONS**

- USE WITH ANY CLEAN LIQUID COMPATIBLE WITH IRON/STEEL
- ★ BOOSTER SERVICE
  - ★ CIRCULATING
  - ★ FILTERING
  - ★ LUBRICATING
  - ★ TRANSFERRING



SEC. 560	PAGE 11
	January 2010

**This Page Intentionally Blank**

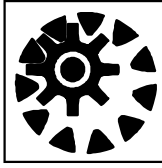

# GHS SERIES Flexible Seal HEAVY DUTY STANDARD STEEL ROTARY GEAR PUMP

This heavy duty series pump is ideal for refining, petrochemical and applications requiring extra strength or shock resistance. The steel construction conforms to ASTM designation A216 Grade WCB. Superior rotor shaft support and an integral, maintenance-free radial/thrust bearing, reduce deflection and wear.

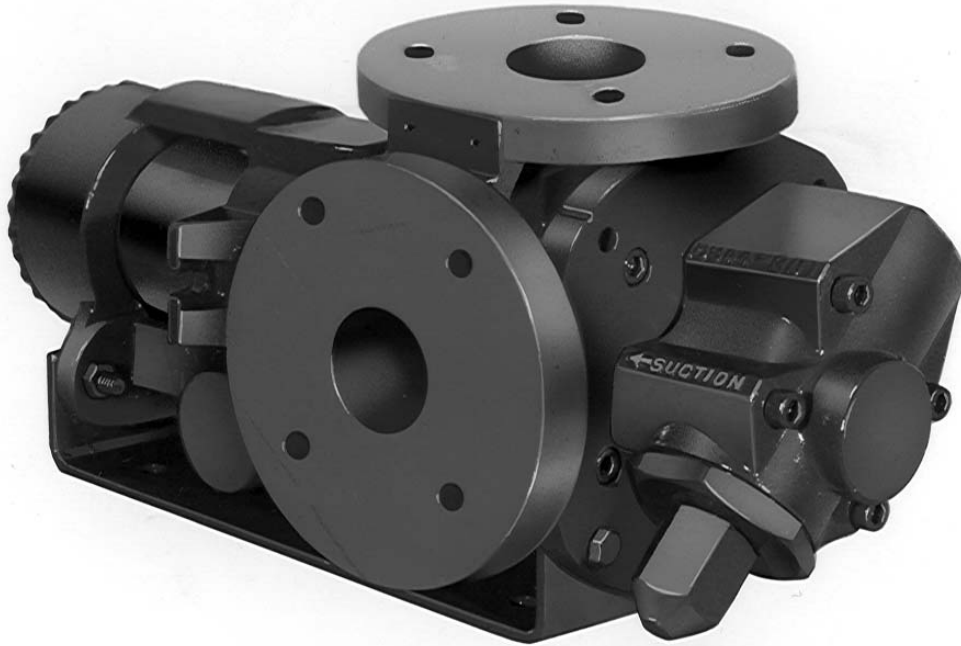

The GHS steel series is designed for applications in the operating ranges noted below. These units are available with head and backhead jackets for temperature control, carbon graphite bushings for low viscosity liquids, silicon carbide bushings for wear resistance, and numerous shaft seal options described on the following pages.

### FEATURES

*400 PSI CAPABILITY*  
*BALL BEARING THRUST CONTROL*  
*ROTOR END CLEARANCE EXTERNALLY ADJUSTABLE*  
*HIGH STRENGTH, COMPUTER PROFILED GEARING FOR QUIET OPERATION*  
*MULTIPLE PORT POSITIONS*  
*FLEXIBLE SEAL DESIGN ALLOWS FOR A VARIETY OF INDUSTRIAL STANDARD SEALS OR PACKING*  
*INTERNAL SEAL VENT*

### OPERATING RANGE

CAPACITY (GPM) : (3 TO 295)  
 [LPM] : [11 TO 1116]

PRESSURE (PSI) : [0 TO 300]  
 [BAR] : [0 TO 21]

VISCOSITY (SSU) : (28 TO 2,000,000)  
 [cSt] : [1 TO 440,000]

TEMPERATURE (F) : (-20° TO 675°)  
 [C] : [-29° TO 358°]

### APPLICATIONS

USE WITH ANY CLEAN LIQUID COMPATIBLE WITH IRON/STEEL

- ★ BOOSTER SERVICE
- ★ CIRCULATING
- ★ FILTERING
- ★ LUBRICATING
- ★ TRANSFERRING

EXTERIOR	BACKHD	ROTOR & IDLER	HOUSING PORTS	BUSHING	IDLER PIN	SHAFT	SHAFT SEALING		ROTA-TION	INTERNAL RELIEF VALVE	
							MECH. SEAL ●	PACKING ■		MATERIAL	SETTING
STEEL ③	DUCTILE IRON	HIGH STRENGTH IRON	150# FLG GHC 180° GHS 90°	BRONZE	HARD STEEL	STEEL	VITON	CARBON FIBER	C.W.	STEEL	75 PSI [5 BAR]

## Standard Models

**G H C 3 JG 32 - B**  
**G H S 3 JG 32 - B**  
 | | | | | | | | | | | |  
 GEAR DUTY DESIGN PORT SIZE HYDRAULIC SEAL STYLE

MODEL NUMBER		NOM. CAPACITY - SPEED				MAXIMUM				SHIPPING DATA			
		MAXIMUM		ALTERNATIVE		DIFF. PRESSURE - PSI [BAR]			TEMP	Wt.	Vol.		
		GPM [LPM]	RPM 60 Hz [50 HZ]	GPM [LPM]	RPM 60 Hz [50 HZ]	BELOW 38 SSU [4 cSt]	38 TO 100 SSU [21 cSt]	100 TO 250,000 SSU [55,000 cSt]	°F [°C]	LBS [KG]	CU. FT.		
GHC	GHS												
GHC 1 DC32-B ① ● †		9 [28]		6 [19]						39 [17,7]	0.6		
GHC 1 DE32-B ① ● †		11 [35]		7 [22]						39 [17,7]	0.6		
GHC 1-1/2 GC32-B ● †	GHS 1-1/2 GC32-B ● † GHS 1-1/2 GC38-B ■ †	16 [50]	1750 [1460]	10 [32]	1150 [960]	100 [7]	150 [10]	300 [21]	GHC ● [177]	71 [32,2]	2.9		
GHC 1-1/2 GF32-B ● †	GHS 1-1/2 GF32-B ● † GHS 1-1/2 GF38-B ■ †	23 [73]		15 [47]						71 [32,2]	2.9		
GHC 1-1/2 GH32-B ● †	GHS 1-1/2 GH32-B ● † GHS 1-1/2 GH38-B ■ †	31 [98]		20 [63]						71 [32,2]	2.9		
GHC 1-1/2 GJ32-B ② ● †	GHS 1-1/2 GJ32-B ② ● † GHS 1-1/2 GJ38-B ② ■ †	38 [120]		25 [79]						71 [32,2]	2.9		
GHC 3 JG32-B ● †	GHS 3 JG32-B ● † GHS 3 JG38-B ■ †	40 [126]	1150 [960]	30 [95]	870 [725]			100 [7]	150 [10]	300 [21]	GHS ● [260]	154 [69,8]	5.3
GHC 3 JJ32-B ● †	GHS 3 JJ32-B ● † GHS 3 JJ38-B ■ †	56 [177]		36 [114]								154 [69,8]	5.3
GHC 3 JL32-B ● †	GHS 3 JL32-B ● † GHS 3 JL38-B ■ †	77 [243]		58 [183]								154 [69,8]	5.3
GHC 3 JP32-B ② ● †	GHS 3 JP32-B ② ● † GHS 3 JP38-B ② ■ †	107 [338]		81 [256]								154 [69,8]	5.3

STANDARD MODELS  
CONTINUED

NOTE: RECOMMENDED PORT SIZES ARE SHOWN IN **BOLDFACE**. EXAMPLE: **GHC 3 JG32-B, GHS 3 JG32-B**

- MECHANICAL SEAL
- LIPSEAL/PACKING
- † PORTS ARE COMPATIBLE WITH 150# ANSI FLANGES. ALL OTHER PORTS ARE TAPPED NPT FOR ANSI PIPE. OPTIONAL [DIN] FLANGES OR TAPPED [BSP] PORTS AVAILABLE FOR EXPORT MARKET.

- ① 3450 [2875] RPM PERMISSIBLE TO 1,000 SSU [220 cSt] AND 100 PSI [7 BAR]
- ② PUMP LIMITED TO 200 PSI MAXIMUM PRESSURE.
- ③ REFER TO REFERENCE SECTION FOR SPECIFIC CONSTRUCTION DETAILS.

**THE GORMAN-RUPP COMPANY • MANSFIELD, OHIO**  
GORMAN-RUPP OF CANADA LIMITED • ST. THOMAS, ONTARIO, CANADA

MODEL NUMBER		NOM. CAPACITY - SPEED				MAXIMUM				SHIPPING DATA	
		MAXIMUM		ALTERNATIVE		DIFF. PRESSURE - PSI [BAR]			TEMP.	Wt.	Vol.
		GPM	RPM	GPM	RPM	BELOW	38 TO	100 TO	° F		
GHC	GHS	[LPM]	60 Hz	[LPM]	60 Hz	38 SSU	100 SSU	250,000 SSU	[° C]	LBS	CU. FT.
			[50 HZ]		[50 HZ]	[4 cSt]	[21 cSt]	[55,000 cSt]		[KG]	
	GHS 2 NK32-B ● † GHS 2 NK38-B ■ †	99 [375]	960 [960]	60 [189]	580 [480]			300 [21]		200	5.3
										[90,7]	
	GHS 3 NK32-B ● † GHS 3 NK38-B ■ †	132 [500]	960 [960]	80 [252]	580 [480]			300 [21]		200	5.3
										[90,7]	
	GHS 2 NM32-B ● † GHS 2 NM38-B ■ †	165 [624]	720 [600]	99 [312]	480 [400]	100 [7]	150 [10]	300 [21]		200	5.3
										[90,7]	
	GHS 3 NP32-B ① ● † GHS 3 NP38-B ① ■ †	172 [542]	720 [600]	115 [362]	480 [400]	100 [7]	150 [10]	300 [21]	GHS ● 400 [204]	302	10.7
										[136,9]	
	GHS 3 RM32-B ● † GHS 3 RM38-B ■ †	215 [678]	720 [600]	143 [451]	480 [400]	100 [7]	150 [10]	300 [21]	GHS ■ 500 [260]	302	10.7
										[136,9]	
	GHS 4 RM32-B ● † GHS 4 RM38-B ■ †	255 [804]	720 [600]	170 [536]	480 [400]	100 [7]	150 [10]	300 [21]		302	10.7
										[136,9]	
	GHS 2-1/2 RP32-B ● † GHS 2-1/2 RP38-B ■ †	295 [930]	720 [600]	196 [618]	480 [400]	100 [7]	150 [10]	300 [21]		302	10.7
										[136,9]	
	GHS 3 RP32-B ● † GHS 3 RP38-B ■ †	255 [804]	720 [600]	170 [536]	480 [400]	100 [7]	150 [10]	300 [21]		302	10.7
										[136,9]	
	GHS 4 RP32-B ● † GHS 4 RP38-B ■ †	295 [930]	720 [600]	196 [618]	480 [400]	100 [7]	150 [10]	300 [21]		302	10.7
										[136,9]	
	GHS 3 RR32-B ● † GHS 3 RR38-B ■ †	295 [930]	720 [600]	196 [618]	480 [400]	100 [7]	150 [10]	300 [21]		302	10.7
										[136,9]	
	GHS 4 RR32-B ● † GHS 4 RR38-B ■ †	295 [930]	720 [600]	196 [618]	480 [400]	100 [7]	150 [10]	300 [21]		302	10.7
										[136,9]	
	GHS 3 RS32-B ① ● † GHS 3 RS38-B ① ■ †	295 [930]	720 [600]	196 [618]	480 [400]	100 [7]	150 [10]	300 [21]		302	10.7
										[136,9]	
	GHS 4 RS32-B ① ● † GHS 4 RS38-B ① ■ †	295 [930]	720 [600]	196 [618]	480 [400]	100 [7]	150 [10]	300 [21]		302	10.7
										[136,9]	

STANDARD MODELS CONTINUED

- MECHANICAL SEAL
- LIPSEAL/PACKING
- † PORTS ARE COMPATIBLE WITH 150# ANSI FLANGES. ALL OTHER PORTS ARE TAPPED NPT FOR ANSI PIPE. OPTIONAL [DIN] FLANGES OR TAPPED [BSP] PORTS AVAILABLE FOR EXPORT MARKET.

① PUMP LIMITED TO 200 PSI MAXIMUM PRESSURE.

**THE GORMAN-RUPP COMPANY • MANSFIELD, OHIO**  
**GORMAN-RUPP OF CANADA LIMITED • ST. THOMAS, ONTARIO, CANADA**

<b>APPLICATION RECOMMENDATIONS:</b>		
<b>APPLICATION</b>	<b>OPTIONS REQUIRED (Select One From Each Row)</b>	<b>OPERATING LIMITATIONS</b>
GHS ONLY HIGH TEMPERATURE	25U, 25V, OR 25W 35J – 35M (AS REQ'D) 40M, 40W 61H, OR 65Q 70K	TEMPERATURE: 675° F MAX. PRESSURE: 200 PSI MAX.
ASPHALT	35J–35M (AS REQ'D) 40M, 40W, 40G 41R, 41W 65S 70, 70K, 71K	TEMPERATURE:500° MAX.
JACKETED	40G, 40J, 40K, 40W, 41U, 41W	LIMIT JACKET PRESSURE TO 150 PSIG

NOTE: PROPER PUMP APPLICATION REQUIRES CONSIDERATION OF ADDITIONAL FACTORS. PLEASE REVIEW APPLICATION GUIDE IN SECTION 500 OR CONSULT THE FACTORY.

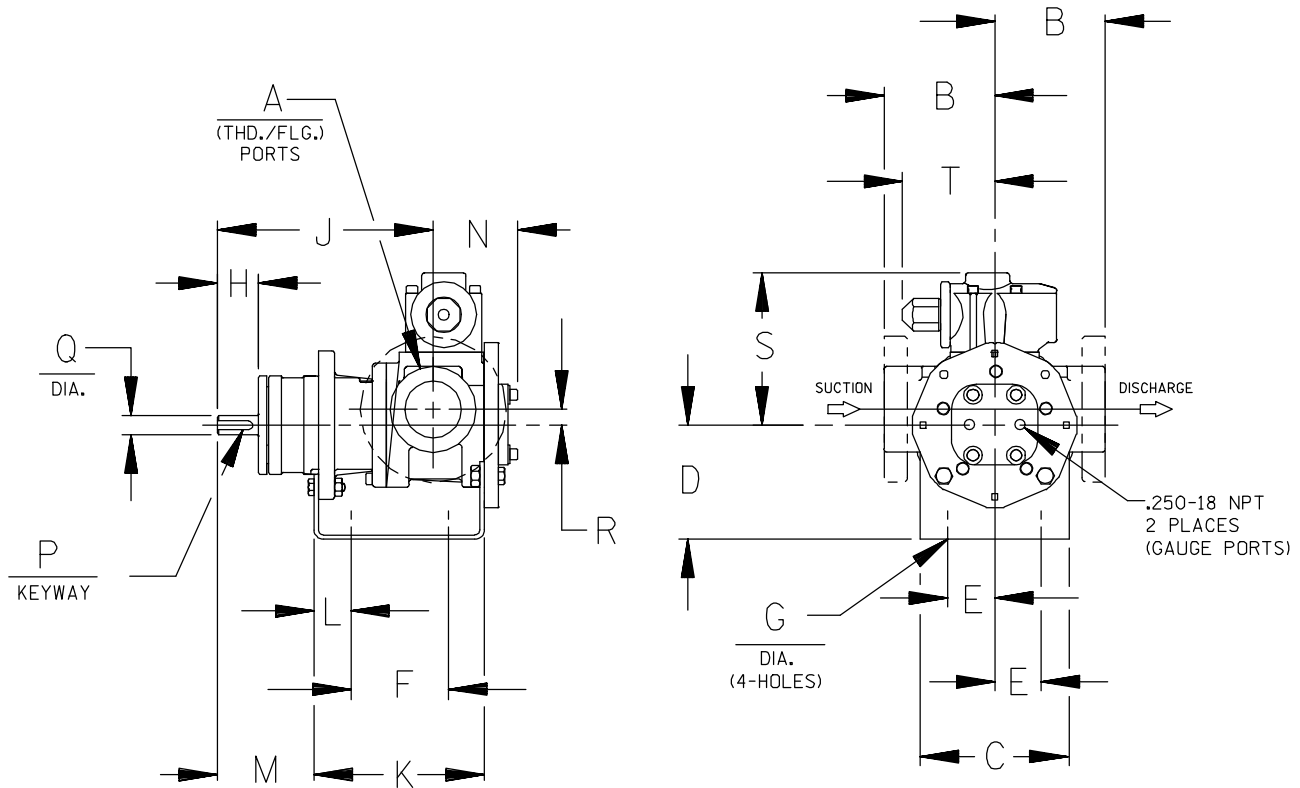

CAD FILE NO.: 16458D

MODEL NUMBERS	PUMP DIMENSIONS - INCHES [MILLIMETERS]																	
	A	B	C	D	E	F	G	H	J	K	L	M	N	P	Q	R	S	T
GHC D	1"	4.00 † [102]	4.00 [102]	3.50* [89] 4.50 [114] 5.25 [133]	1.62 [41]	3.12 [79]	.41 [10]	1.16 [30]	6.19 [157]	5.04 [128]	.76 [19]	2.62 [66]	2.74 [70]	.12 [3] x .75 [19]	.50 [13]	.62 [16]	5.19 [132]	3.58 [91]
GHC G	1-1/2"	4.00 † [102]	5.88 [149]	3.50* [89] 4.50 [114] 5.25 [133] 6.25 [159]	1.62 [41]	4.00 [102]	.41 [10]	1.62 [41]	8.50 [216]	6.71 [170]	1.06 [27]	3.82 [97]	3.35 [85]	.19 [5] x 1.25 [32]	.75 [19]	.62 [16]	6.00 [152]	3.62 [92]
GHC J	3"	6.00* [152] †  6.31 † [160]	6.88 [175]	4.50 [114] 5.25* [133] 6.25 [159] 7.00 [178] 8.00 [203]	2.88 [73]	4.25 [108]	.44 [11]	2.50 [64]	12.12 [308]	9.75 [248]	1.75 [44]	5.50 [140]	4.66 [118]	.25 [6] x 2.00 [51]	1.00 [25]	1.12 [28]	9.06 [230]	6.75 [171]

\* STANDARD DIMENSION  
PORTS ARE COMPATIBLE WITH 150# OR 300# ANSISTEEL FLANGES. ALL OTHER PORTS ARE TAPPED NPT  
† FOR ANSIPIPE. OPTIONAL [DIN FLANGES OR TAPPED [BSP] PORTS AVAILABLE FOR EXPORT MARKET.  
NPT FOR ANSIPIPE. OPTIONAL (DIN) FLANGES OR TAPPED (BSP) PORTS AVAILABLE FOR EXPORT MARKET.  
‡ 90° HOUSING

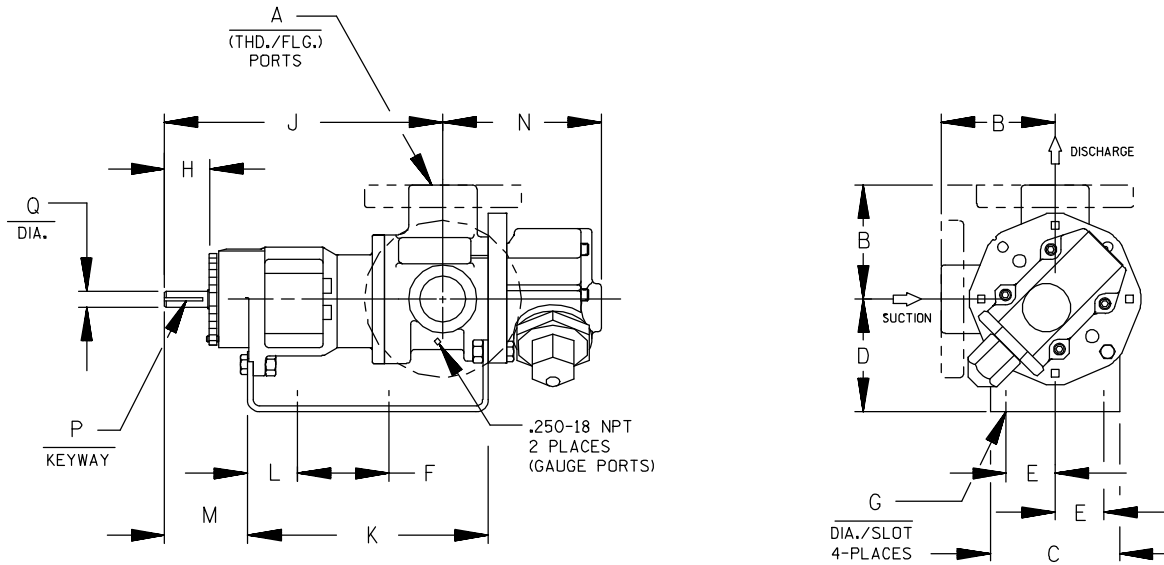

CAD FILE NO.: 16669F

MODEL NUMBERS	PUMP DIMENSIONS - INCHES [MILLIMETERS]														
	A	B	C	D	E	F	G	H	J	K	L	M	N	P	Q
GHS G	1-1/2"	4.00 [102]	4.88 [124]	3.50 [89] * 4.50 [114] 5.25 [133] 6.25 [159]	1.62 [41]	8.00 [203]	.41 [10]	1.62 [41]	12.06 [306]	10.72 [272]	1.52 [39]	3.35 [85]	5.70 [145]	.19 [5] x 1.25 [32]	.75 [19]
GHS J	3"	6.00 † [152] 6.31 [160]	6.88 [175]	5.25 [133] * 6.25 [159] 7.00 [178] 8.00 [203]	2.88 [73]	10.00 [254]	.44 [11]	2.50 [64]	15.68 [398]	14.31 [363]	2.77 [70]	4.48 [114]	8.50 [216]	.25 [6] x 2.00 [51]	1.00 [25]
GHS N	2"	5.25 * [133] 5.38 [137]	8.00 [203]	4.50 [114] 5.25 [133] * 6.25 [159] 7.00 [178] 8.00 [203]	2.88 [73]	10.00 [254]	.44 [11]	2.58 [66]	16.37 [416]	15.14 [385]	2.69 [68]	4.56 [116]	7.59 [193]	.25 [6] x 2.00 [51]	1.12 [32]
	3"	7.19 [183]											8.72 [221] *		
GHS R	2-1/2"														
	3"	7.19 [183]	10.50 [267]	7.00 [178]	3.75 [95]	13.75 [349]	.52 [13]	2.25 [57]	17.87 [454]	17.36 [441]	1.80 [46]	4.70 [119]	11.31 [287]	.38 [10] x 1.88 [48]	1.44 [37]
	4"														

\* STANDARD DIMENSION

† PORTS ARE COMPATIBLE WITH 150\* OR 300\* ANSISTEEL FLANGES. ALL OTHER PORTS ARE TAPPED NPT FOR ANSIPIPE. OPTIONAL (DIN) FLANGES OR TAPPED (BSP) PORTS AVAILABLE FOR EXPORT MARKET.

† 180° HOUSING



# **GHC/GHS**

**FOR GHC DRIVE OPTIONS  
AND DIMENSIONS**

**SEE**

**SECTION 540**

**FOR GHS DRIVE OPTIONS  
AND DIMENSIONS**

**SEE**

**SECTION 545**



# PERFORMANCE CURVES

## SPEED VS. CAPACITY/HORSEPOWER

**GC** Hydraulic Size

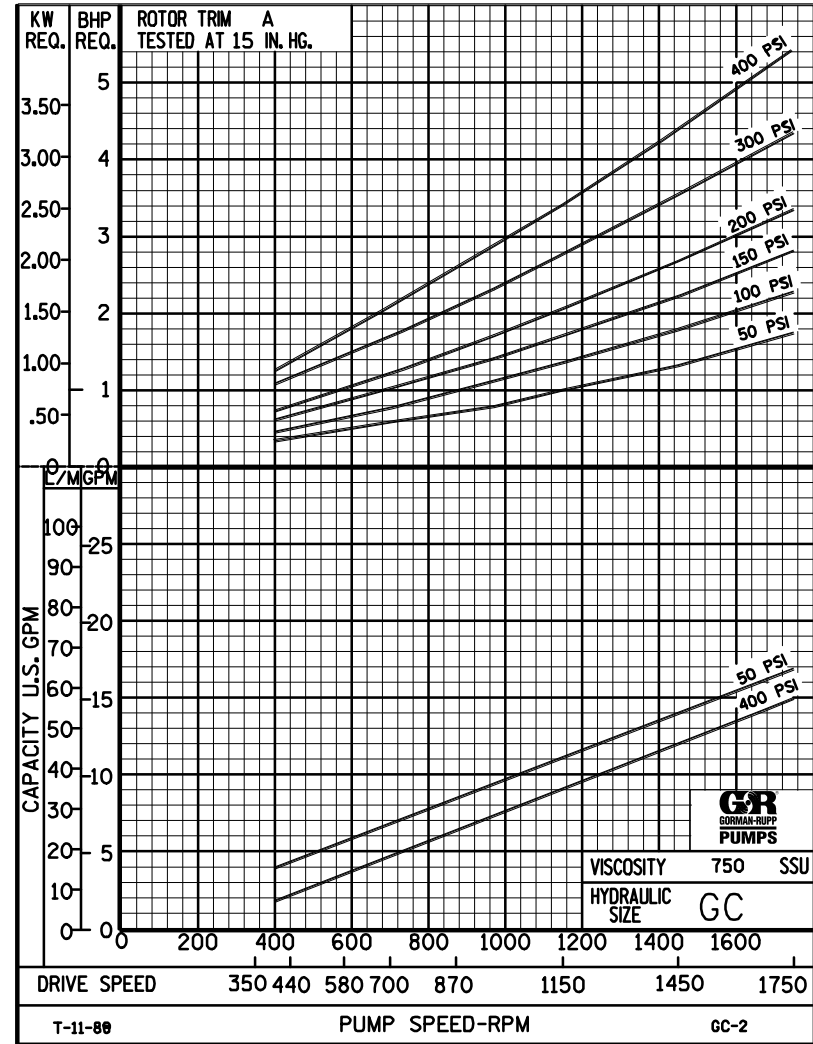
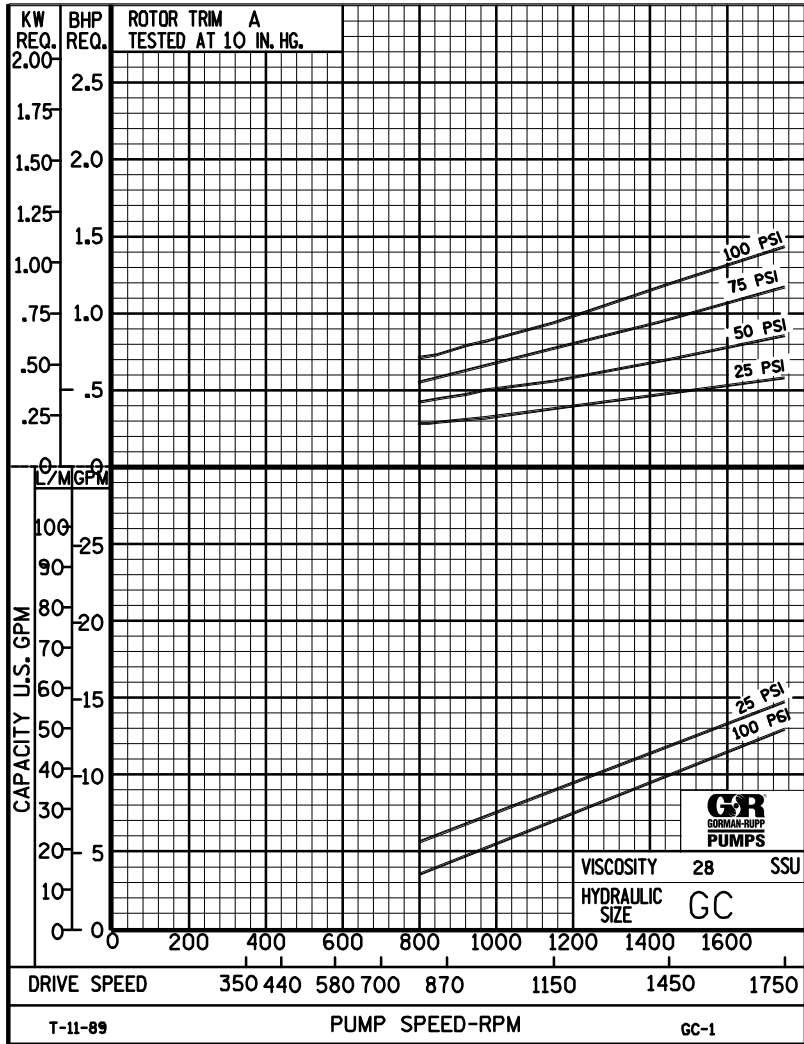

**THE GORMAN-RUPP COMPANY • MANSFIELD, OHIO**  
 GORMAN-RUPP OF CANADA LIMITED • ST. THOMAS, ONTARIO, CANADA

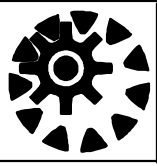

# PERFORMANCE CURVES

## SPEED VS. CAPACITY/HORSEPOWER

**GC** Hydraulic Size

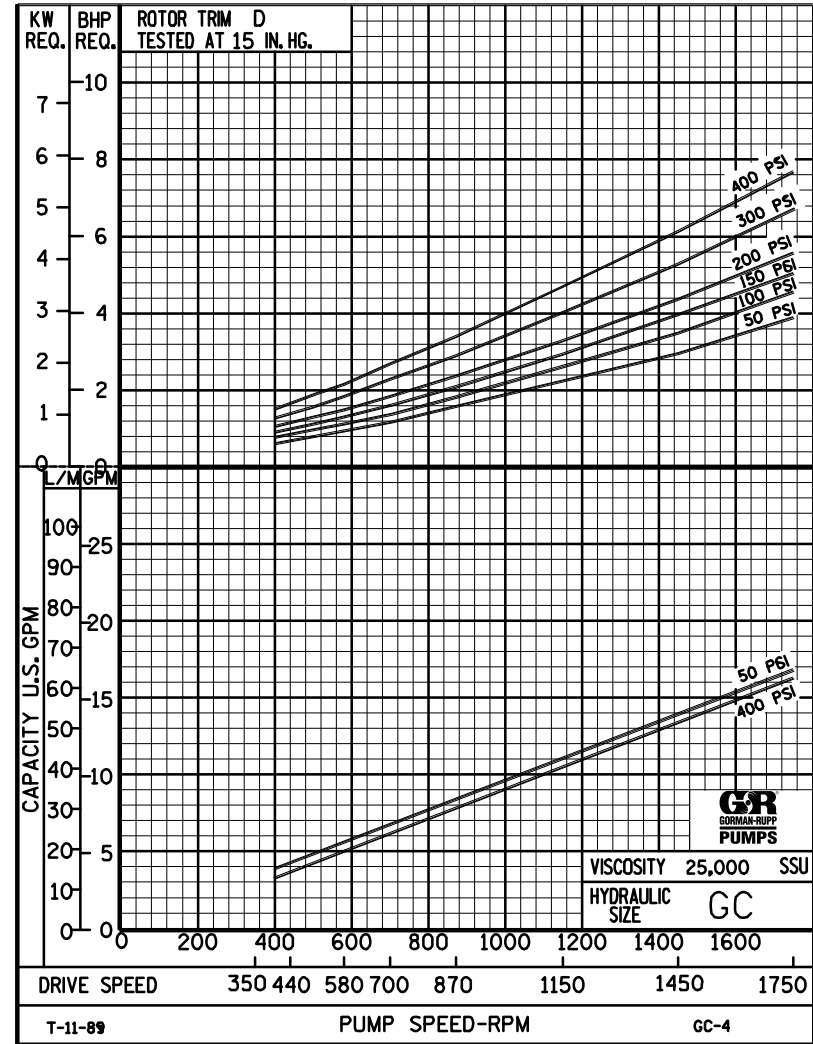
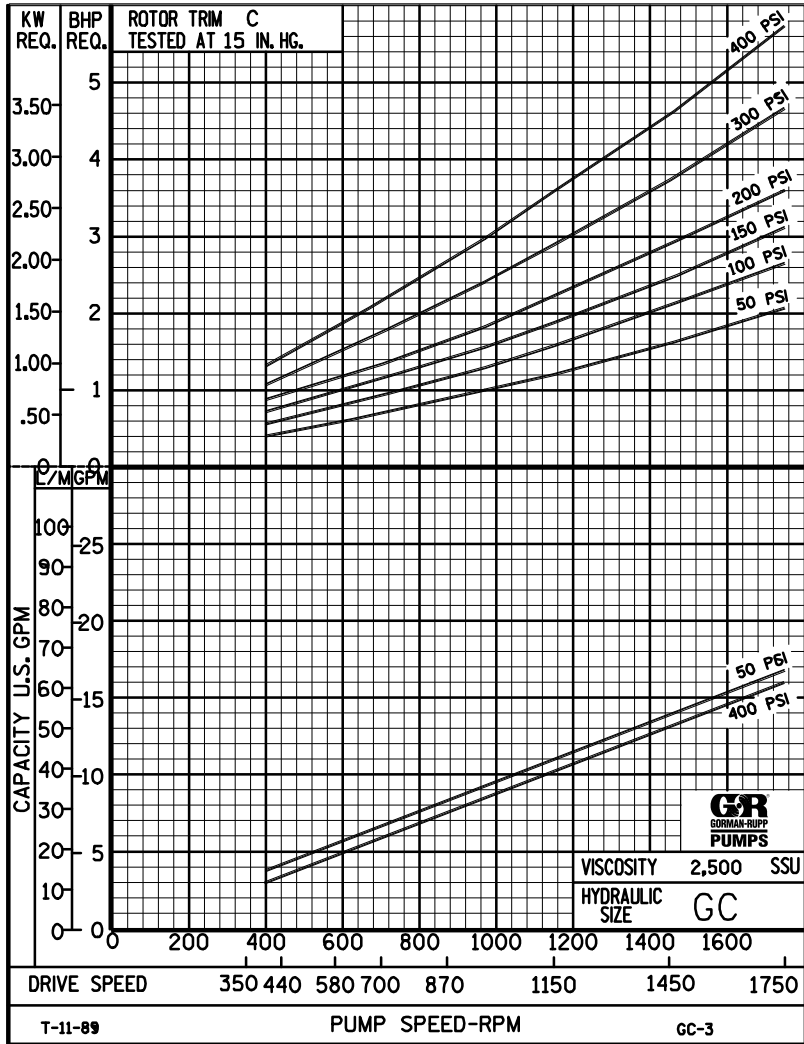

**THE GORMAN-RUPP COMPANY • MANSFIELD, OHIO**  
 GORMAN-RUPP OF CANADA LIMITED • ST. THOMAS, ONTARIO, CANADA

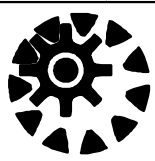

# GC

## PUMP HYDRAULIC SIZE CHART

SEC. 500

Page 40

January 2010

**16 GPM  
1750 RPM**

NOMINAL		ROTOR TRIM	VISCOSITY (SSU)	N.I.P.R. (PSIA)	FRICTION PIPE LOSS (PSI/FT) <small>(Based on Sch 40 Steel Pipe)</small>					FULL BYPASS RELIEF VALVE PRESSURE (PSI)					CAPACITY (GPM) / H.P. REQUIRED											
CAP. GPM	SPEED RPM				PIPE DIAMETER					CRACKING PRESS. (PSI)					DIFFERENTIAL PRESSURE (PSI)											
					3/4"	1"	1 1/4"	1 1/2"	2"	LOW PRES R/V			HI PRES R/V		MEDIUM DUTY AND HEAVY DUTY				HEAVY DUTY ONLY							
16	1750	STD	28	3.6	.01	.01	.01	.01	.01	60	87	112			14.0	13.0	13.0	12.0								
			32		.19	.06	.02	.01	.01						.58	.85	1.2	1.4								
			38	3.6	.24	.08	.02	.01	.01	60	87	112	162			15.0	14.0	14.0	13.0	12.0						
			50		.30	.10	.03	.01	.01							.88	1.0	1.3	1.6	2.2						
			70	3.6	.35	.11	.03	.02	.01	61	88	114	164	216			16.0	15.0	15.0	14.0	14.0	13.0				
			100		.40	.13	.03	.02	.01								1.1	1.2	1.5	1.8	2.3	2.8				
			150	3.6	.45	.16	.04	.02	.01	61	88	114	164	218			16.0	16.0	16.0	15.0	15.0	14.0	14.0	12.0		
			200		.50	.19	.06	.04	.01								1.2	1.4	1.7	2.0	2.5	3.1	4.1	5.2		
			300	3.6	.62	.24	.08	.04	.02	61	88	116	166	220			16.0	16.0	16.0	16.0	15.0	15.0	15.0	13.0		
			500		1.02	.39	.13	.07	.03								1.4	1.6	2.0	2.2	2.8	3.3	4.2	5.4		
		750	3.6	1.53	.59	.20	.11	.04	61	88	116	166	223			17.0	17.0	16.0	16.0	16.0	16.0	15.0	15.0			
		1,000		2.04	.78	.26	.14	.05								1.5	1.8	2.0	2.3	2.8	3.3	4.3	5.5			
		2,000	4.5	4.08	1.56	.52	.28	.11	63	91	116	166	223			17.0	16.0	16.0	16.0	16.0	16.0	16.0	15.0			
		3,500		7.14	2.72	.91	.49	.18								1.8	2.1	2.4	2.7	3.1	3.6	4.7	5.7			
		5,000	5.0	10.2	3.89	1.30	.70	.26	66	93	118	168	225			17.0	16.0	16.0	16.0	16.0	16.0	16.0	16.0			
		7,500		15.3	5.83	1.95	1.05	.39								2.2	2.6	3.0	3.2	3.7	4.1	5.2	6.2			
		10,000	5.7	20.4	7.77	2.60	1.40	.52	69	95	120	170	225			17.0	16.0	16.0	16.0	16.0	16.0	16.0	16.0			
		15,000		30.6	11.7	3.89	2.10	.78								2.8	3.2	3.5	3.8	4.3	4.8	5.9	6.9			
		20,000	6.1	40.8	15.6	5.19	2.80	1.03	73	98	123	173	225			16.0	16.0	16.0	16.0	16.0	16.0	16.0	16.0			
		25,000		51.0	19.4	6.49	3.50	1.29								3.4	3.9	4.2	4.6	5.0	5.6	6.6	7.7			
50,000																										
75,000																										
100,000																										
150,000																										
200,000																										
250,000																										

(NOTE) For speeds not shown on the pump hydraulic charts, consult factory.



# GC

## PUMP HYDRAULIC SIZE CHART

SEC. 500

Page 41

January 2010

**10 GPM  
1150 RPM**

NOMINAL		ROTOR TRIM	VISCOSITY (SSU)	N.I.P.R. (PSIA)	FRICTION PIPE LOSS (PSI/FT) <small>(Based on Sch 40 Steel Pipe)</small>					FULL BYPASS RELIEF VALVE PRESSURE (PSI)					CAPACITY (GPM) / H.P. REQUIRED											
CAP. GPM	SPEED RPM				PIPE DIAMETER					CRACKING PRESS. (PSI)					DIFFERENTIAL PRESSURE (PSI)											
					3/4"	1"	1 1/4"	1 1/2"	2"	LOW PRES R/V			HI PRES R/V		MEDIUM DUTY AND HEAVY DUTY				HEAVY DUTY ONLY							
10	1150	STD	28	2.0	.01	.01	.01	.01	.01	56	81	106			9.0	8.0	7.0	6.0								
			32		.08	.03	.01	.01	.01						.38	.56	.77	.94								
			38	2.0	.11	.04	.01	.01	.01	56	81	106	157			9.5	8.5	8.5	7.5	6.0						
			50		.13	.04	.01	.01	.01							.43	.62	.82	.99	1.6						
			70	2.0	.14	.05	.02	.01	.01	56	81	107	158	209			10.0	9.5	9.5	9.0	8.0	7.5				
			100		.14	.05	.02	.01	.01								.54	.78	1.0	1.2	1.7	1.9				
			150	2.0	.17	.07	.03	.02	.01	57	82	108	158	211			10.0	10.0	10.0	10.0	9.5	8.5	7.5	6.0		
			200		.30	.12	.04	.02	.01								.58	.82	1.0	1.2	1.7	2.0	2.7	3.4		
			300	2.0	.39	.15	.05	.02	.01	57	82	109	159	212			11.0	10.0	10.0	10.0	10.0	10.0	9.0	7.5		
			500		.64	.24	.08	.05	.02								.66	.95	1.2	1.4	1.8	2.0	2.8	3.5		
		750	2.0	.96	.36	.12	.07	.03	57	82	111	161	214			11.0	11.0	11.0	11.0	10.0	10.0	9.5	9.0			
		1,000		1.28	.49	.16	.09	.03								.73	1.0	1.2	1.4	1.8	2.1	2.9	3.5			
		2,000	2.5	2.55	.97	.33	.18	.07	58	85	112	162	214			11.0	11.0	11.0	11.0	10.0	10.0	10.0	10.0			
		3,500		4.46	1.70	.57	.31	.12								.91	1.3	1.5	1.7	2.0	2.3	3.0	3.7			
		5,000	2.9	6.38	2.43	.81	.44	.16	60	85	112	162	214			11.0	11.0	11.0	11.0	11.0	10.0	10.0	10.0			
		7,500		9.57	3.64	1.22	.66	.24								1.1	1.5	1.8	1.9	2.4	2.6	3.3	3.9			
		10,000	3.2	12.8	4.86	1.62	.88	.32	63	88	114	166	216			11.0	11.0	11.0	11.0	11.0	11.0	10.0	10.0			
		15,000		19.2	7.29	2.43	1.31	.49								1.3	1.9	2.1	2.2	2.7	2.9	3.6	4.3			
		20,000	3.5	25.5	9.71	3.24	1.75	.65	66	91	116	168	218			11.0	11.0	11.0	11.0	11.0	11.0	10.0	10.0			
		25,000		31.9	12.2	4.05	2.19	.81								1.7	2.3	2.4	2.6	2.9	3.3	4.0	4.7			
50,000	5.4	63.8	24.3	8.11	4.38	1.61	69	94	122	172	224			11.0	11.0	11.0	11.0	11.0	11.0	10.0	10.0					
75,000		95.7	36.4	12.2	6.56	2.42								2.6	3.6	3.8	4.0	4.5	5.2	6.0	6.8					
100,000																										
150,000																										
200,000																										
250,000																										

(NOTE) For speeds not shown on the pump hydraulic charts, consult factory.

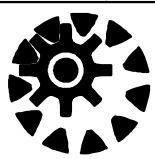

# GC

## PUMP HYDRAULIC SIZE CHART

SEC. 500

Page 42

January 2010

**8 GPM  
870 RPM**

NOMINAL		ROTOR TRIM	VISCOSITY (SSU)	N.I.P.R. (PSIA)	FRICTION PIPE LOSS (PSI/FT) <small>(Based on Sch 40 Steel Pipe)</small>					FULL BYPASS RELIEF VALVE PRESSURE (PSI)					CAPACITY (GPM) / H.P. REQUIRED														
CAP. GPM	SPEED RPM				PIPE DIAMETER					CRACKING PRESS. (PSI)					DIFFERENTIAL PRESSURE (PSI)														
					3/4"	1"	1 1/4"	1 1/2"	2"	LOW PRES R/V			HI PRES R/V		MEDIUM DUTY AND HEAVY DUTY				HEAVY DUTY ONLY										
8	870	STD	28	1.4	.01	.01	.01	.01	.01	56	81	106				6.5	5.5	4.5	4.0										
			32		.06	.02	.01	.01	.01							.28	.45	.61	.77										
			38	1.4	.07	.03	.01	.01	.01	56	81	106	157				7.0	6.5	6.0	5.5	4.5								
			50		.09	.03	.01	.01	.01								.39	.49	.65	.79	1.2								
			70	1.4	.10	.04	.01	.01	.01	56	81	107	158	209				7.5	7.5	7.0	6.5	6.0	5.5						
			100		.10	.04	.01	.01	.01									.42	.53	.71	.83	1.2	1.4						
			150	1.4	.15	.05	.02	.01	.01	57	82	108	158	211				8.0	8.0	7.5	7.5	7.5	7.0	6.0	4.5				
			200		.24	.08	.03	.02	.01									.44	.55	.74	.90	1.2	1.5	2.0	2.6				
			300	1.4	.31	.12	.04	.02	.01	57	82	109	159	212				8.5	8.0	8.0	8.0	7.5	7.0	6.5	5.5				
			500		.51	.19	.07	.04	.01									.52	.64	.80	.97	1.3	1.5	2.1	2.6				
			750	1.4	.77	.29	.10	.05	.02	57	82	111	161	214				8.5	8.5	8.0	8.0	8.0	8.0	7.0	6.5				
			1,000		1.02	.39	.14	.07	.03									.62	.71	.86	1.0	1.3	1.5	2.1	2.6				
		2,000	1.8	2.04	.78	.26	.14	.05	58	85	112	162	214				8.5	8.0	8.0	8.0	8.0	8.0	7.5	7.5					
		3,500		3.57	1.36	.46	.25	.09									.76	.90	1.0	1.4	1.5	1.6	2.2	2.7					
		5,000	2.1	5.01	1.94	.65	.35	.13	60	85	112	162	214				8.5	8.0	8.0	8.0	8.0	8.0	8.0	7.5					
		7,500		7.65	2.91	.97	.53	.19									.92	1.2	1.3	1.4	1.6	1.9	2.3	2.9					
		10,000	2.4	10.2	3.88	1.30	.70	.26	63	88	114	166	216				8.5	8.0	8.0	8.0	8.0	8.0	8.0	7.5					
		15,000		15.3	5.83	1.95	1.05	.39									1.1	1.4	1.5	1.6	1.8	2.1	2.6	3.2					
		20,000	2.7	20.4	7.77	2.59	1.40	.52	66	91	116	168	218				8.0	8.0	8.0	8.0	8.0	8.0	8.0	8.0					
		25,000		25.5	9.71	3.24	1.75	.65									1.2	1.6	1.7	1.8	2.1	2.3	2.9	3.4					
		50,000	4.3	51.1	19.4	6.50	3.50	1.29	68	93	120	170	222				8.0	8.0	8.0	8.0	8.0	8.0	8.0	8.0					
		75,000		76.5	29.1	9.73	5.25	1.93									1.8	2.5	2.6	2.7	3.0	3.3	3.8	4.3					
		100,000	6.2	102	38.9	13.0	7.00	2.58	70	95	122	172	224				8.0	8.0	8.0	8.0	8.0	8.0	8.0	8.0					
		150,000		153	58.0	19.5	10.5	3.87									2.3	3.1	3.3	3.4	3.6	3.9	4.4	5.0					
200,000																													
250,000																													

(NOTE) For speeds not shown on the pump hydraulic charts, consult factory.



# GC

## PUMP HYDRAULIC SIZE CHART

SEC. 500

Page 43  
January 2010

**5 GPM  
580 RPM**

NOMINAL		ROTOR TRIM	VISCOSITY (SSU)	N.I.P.R. (PSIA)	FRICTION PIPE LOSS (PSI/FT) <small>(Based on Sch 40 Steel Pipe)</small>					FULL BYPASS RELIEF VALVE PRESSURE (PSI)					CAPACITY (GPM) / H.P. REQUIRED														
CAP. GPM	SPEED RPM				STD	PIPE DIAMETER	3/4"	1"	1 1/4"	1 1/2"	2"	CRACKING PRESS. (PSI)					DIFFERENTIAL PRESSURE (PSI)												
		LOW PRES R/V										HI PRES R/V					MEDIUM DUTY AND HEAVY DUTY				HEAVY DUTY ONLY								
		50	75	100								150	200	50	75	100	150	200	25	50	75	100	150	200	300	400			
5	580	STD	28	1.0	.01	.01	.01	.01	.01	55	80	105			4.0	3.5	3.0	2.5											
			32	1.0	.03	.01	.01	.01	.01							.19	.29	.40	.50										
			38	1.0	.04	.01	.01	.01	.01	55	80	105	156			4.5	4.0	3.5	3.0	2.5									
			50	1.0	.05	.02	.01	.01	.01							.21	.32	.45	.52	.76									
			70	1.0	.06	.02	.01	.01	.01	55	80	106	157	208		5.0	4.5	4.0	4.0	3.5	3.5								
			100	1.0	.07	.03	.01	.01	.01							.25	.34	.46	.54	.78	.93								
			150	1.0	.09	.04	.01	.01	.01	56	81	107	157	210		5.0	5.0	4.5	4.5	4.5	4.0	3.5	3.0						
			200	1.0	.17	.06	.02	.01	.01							.28	.36	.48	.59	.78	.95	1.3	1.3						
			300	1.0	.22	.08	.03	.02	.01	56	81	108	158	211		5.5	5.0	5.0	5.0	4.5	4.5	4.0	3.5						
			500	1.0	.35	.14	.05	.03	.01							.34	.42	.52	.63	.80	.97	1.3	1.6						
		750	1.0	.53	.20	.07	.04	.02	56	81	110	160	213		5.5	5.5	5.5	5.5	5.0	5.0	4.5	4.0							
		1,000	1.0	.70	.27	.09	.05	.02							.41	.46	.56	.65	.82	.99	1.4	1.7							
		2,000	1.3	1.40	.54	.18	.10	.04	57	84	111	161	213		5.5	5.5	5.5	5.5	5.0	5.0	5.0	4.5							
		3,500	1.3	2.46	.94	.31	.17	.06							.49	.59	.67	.77	.92	1.1	1.4	1.7							
		5,000	1.6	3.51	1.34	.45	.24	.09	59	84	111	161	213		5.5	5.5	5.5	5.5	5.5	5.5	5.0	5.0							
		7,500	1.6	5.26	2.00	.67	.36	.13							.61	.75	.84	.93	1.1	1.2	1.5	1.9							
		10,000	1.9	7.01	2.67	.89	.48	.18	62	87	113	165	215		5.5	5.5	5.5	5.5	5.5	5.5	5.0	5.0							
		15,000	1.9	10.5	4.00	1.34	.72	.27							.70	.89	.96	1.1	1.2	1.4	1.7	2.1							
		20,000	2.1	14.1	5.34	1.78	.96	.36	65	90	115	167	217		5.5	5.5	5.5	5.5	5.5	5.5	5.0	5.0							
		25,000	2.1	17.6	6.68	2.23	1.20	.44							.75	.94	1.0	1.1	1.3	1.5	1.9	2.2							
		50,000	3.6	35.0	13.4	4.46	2.41	.89	67	92	119	169	221		5.5	5.5	5.5	5.5	5.5	5.5	5.0	5.0							
		75,000	3.6	52.6	20.0	6.69	3.61	1.33							1.3	1.6	1.7	1.7	1.9	2.1	2.4	2.8							
		100,000	5.4	70.2	26.7	8.92	4.81	1.77	69	94	121	171	223		5.5	5.5	5.5	5.5	5.5	5.5	5.0	5.0							
		150,000	5.4	105	40.1	13.4	7.22	2.66							1.6	2.1	2.1	2.2	2.4	2.5	2.8	3.2							
		200,000	8.6	140	53.4	17.8	9.63	3.54	75	100	129	179	235		5.5	5.5	5.5	5.5	5.5	5.5	5.0	5.0							
		250,000	8.6	175	66.8	22.3	12.1	4.43							1.9	2.5	2.5	2.6	2.8	2.9	3.2	3.6							

(NOTE) For speeds not shown on the pump hydraulic charts, consult factory.



# GC

SEC. 500

PAGE 43.1

February 2025

**2 GPM**  
**200 RPM**

NOMINAL		VISCOSITY		N.I.P.R.	FRICTION PIPE LOSS (PSI/FT) <small>(Schedule 40 Steel Pipe)</small>					CAPACITY (GPM)				H.P. REQUIRED							
GPM	RPM	ROTOR TRIM	(SSU)	(PSIa)	PIPE DIAMETER					MEDIUM-DUTY & HEAVY-DUTY				HEAVY-DUTY ONLY							
					1½"	2"	2½"	3"	4"	DIFFERENTIAL PRESSURE (PSI)											
										25	50	75	100	150	200	300	400				
2	200	STD																			
				"D"	200,000	2.1	3.5	1.3	0.6	0.3	0.09	1.9	1.9	1.9	1.9	1.9	1.9	1.9	1.9	1.9	
			399,999		7		2.6	1.3	0.5	0.2	0.6	0.7	0.7	0.7	0.8	0.9	0.9	0.9	1.0		
			400,000		2.3	1.9	1.9	1.9	1.9	1.9	1.9	1.9	1.9	1.9	1.9	1.9	1.9	1.9	1.9	1.9	
			599,999			0.8	0.8	0.8	0.9	0.9	0.9	1.0	1.1	1.1							
			600,000		2.9	1.9	1.9	1.9	1.9	1.9	1.9	1.9	1.9	1.9	1.9	1.9	1.9	1.9	1.9	1.9	
			799,999			0.8	0.9	0.9	1.0	1.0	1.1	1.1	1.2								
			800,000		3.2	1.9	1.9	1.9	1.9	1.9	1.9	1.9	1.9	1.9	1.9	1.9	1.9	1.9	1.9	1.9	
			1M			0.9	1.0	1.0	1.1	1.1	1.2	1.2	1.3								

(NOTE) For speeds not shown on the pump hydraulic charts, consult factory.