

**GMC SERIES
 MEDIUM DUTY COMPACT
 ROTARY GEAR PUMP**

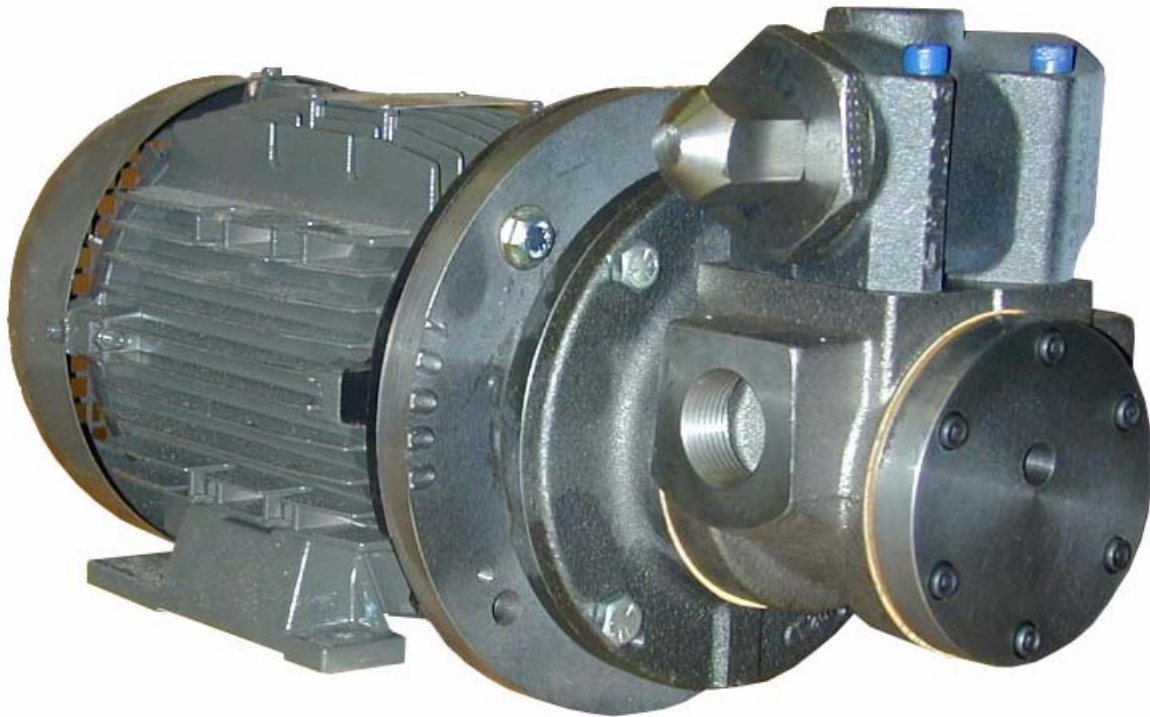

The GMC series is designed for applications in the operating ranges noted below. Direct connecting to other pieces of equipment provides an extremely compact system design.

The six sizes of Gorman-Rupp close coupled pumps connect to standard NEMA "C" flanges. Rotor shaft bores accept standard motor shafts; 5/8" standard, 7/8", 1-1/8" and 1-3/8" are optional. Metric coupling also available.

At synchronous speeds, extra drive equipment, including couplings or outboard bearings, is not required.

For continuous service, or for handling viscous liquids, see the heavy duty GHS section.

FEATURES

*200 PSI CAPABILITY
 COMPACT-NEMA C MOUNTING - NO
 DRIVE COUPLING OR GUARD
 ACCURATE ALIGNMENT
 INEXPENSIVE PUMP/DRIVE UNIT
 THRUST CONTROLLED PUMP
 ELEMENTS
 LONG LIFE - QUIET OPERATION
 MULTIPLE PORT POSITIONING*

OPERATING RANGE

CAPACITY (GPM) : (3 TO 38)
 [LPM] : [11 TO 144]
 PRESSURE (PSI) : (0 TO 200)
 [BAR] : [0 TO 14]
 VISCOSITY (SSU) : (28 TO 250,000)
 [cSt] : [1 TO 55,000]
 TEMPERATURE (F) : (-60° TO 300°)
 [C] : [-51° TO 149°]

APPLICATIONS

USE WITH ANY CLEAN LIQUID
 COMPATIBLE WITH CAST
 IRON

- ★ BOOSTER SERVICE
- ★ CIRCULATING
- ★ FILTERING
- ★ LUBRICATING
- ★ TRANSFERRING

EXTER- IOR	ROTOR & IDLER	HOUSING PORTS	BUSHINGS	IDLER PIN	SHAFT	SHAFT SEALING		ROTATION	INTERNAL RELIEF VALVE	
						MECH. SEAL ●	LIPSEAL ■		MATERIAL	SETTING
CAST IRON	HIGH STRENGTH IRON	180° TAPPED	BRONZE	HARDENED STEEL	STEEL	VITON	BUNA-N	C.W.	DUCTILE IRON	75 PSI [5 BAR]

Standard Models

G M C 1 DC 3 - B
 | | | | | | | | | |
 GEAR DUTY DESIGN PORT-SIZE HYDRAULIC SEAL STYLE
 SIZE SIZE

MODEL NUMBER	NOM. CAPACITY - SPEED				MAXIMUM				SHIPPING DATA	
	MAXIMUM		ALTERNATIVE		DIFFERENTIAL PRESSURE - PSI [BAR]			TEMP.	Weight	Volume
	GPM [LPM]	RPM 60 Hz [50 HZ]	GPM [LPM]	RPM 60 Hz [50 HZ]	BELOW 38 SSU [4 cSt]	38 TO 100 SSU [21 cSt]	100 TO 250,000 SSU [55,000 cSt]	°F [°C]	LBS [KG]	CU. FT.
GMC 1DC 3-B ● GMC 1DC 4-B ■	9 [28]	1750 [1460]	6 [19]	1150 [960]	100 [7]	150 [10]	200 [14]	● 300 [149]	20 [9,0]	0.6
GMC 1DE 3-B ● GMC 1DE 4-B ■	11 [35]		7 [22]						20 [9,0]	0.6
GMC 1-1/2GC 3-B ● GMC 1-1/2GC 4-B ■	16 [50]		10 [32]						32 [14,5]	0.6
GMC 2GC 3-B ● GMC 2GC 4-B ■	23 [73]		15 [47]						32 [14,5]	0.6
GMC 1-1/2GF 3-B ● GMC 1-1/2GF 4-B ■									32 [14,5]	0.6
GMC 2GF 3-B ● GMC 2GF 4-B ■	31 [98]		20 [63]						32 [14,5]	0.6
GMC 1-1/2GH 3-B ● GMC 1-1/2GH 4-B ■									32 [14,5]	0.6
GMC 2GH 3-B ● GMC 2GH 4-B ■									32 [14,5]	0.6
GMC 1-1/2GJ 3-B ● GMC 1-1/2GJ 4-B ■	38 [120]		25 [79]							
GMC 2GJ 3-B ● GMC 2GJ 4-B ■									32 [14,5]	0.6

NOTE: RECOMMENDED PORT SIZES ARE SHOWN IN **BOLDFACE**. Example: **GMC 2GJ 3-B**

NOTE: PROPER PUMP APPLICATION REQUIRES CONSIDERATION OF ADDITIONAL FACTORS. PLEASE REVIEW APPLICATION GUIDE IN SECTION 500 OR CONSULT THE FACTORY.

THE GORMAN-RUPP COMPANY • MANSFIELD, OHIO
 GORMAN-RUPP OF CANADA LIMITED • ST. THOMAS, ONTARIO, CANADA

Basic Pump Dimensions

* STANDARD DIMENSION

† 90° HOUSING

MOTOR FRAMES 56C, 143TC, 145TC, 182C, 184C

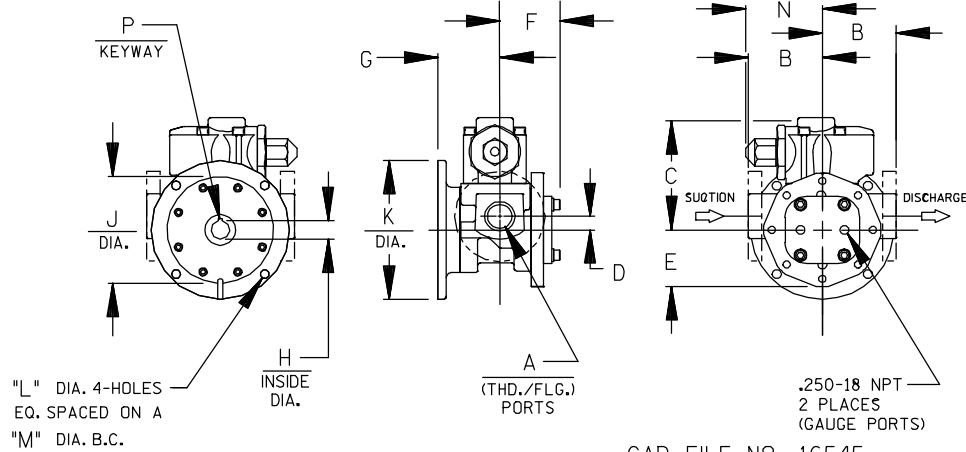

CAD FILE NO.: 16545

PUMP MODEL	PUMP DIMENSIONS - INCHES [MM]							PUMP MOUNTING DIMENSIONS							
	A	B	C	D	E	F	G	H	J	K	L	M	N	P	
GMC D	1"	2.50 † [64]	5.19 [132]	.62 [16]	2.67 [68]	2.73 [69]	2.79 [71]	.62 † [16]	4.50 [114]	6.50 [165]	.41 [10]	5.88 [149]	3.58 [91]	.19 [5]	1.66 [42]
		2.75 * [70]													
GMC G	1-1/2"	3.50 † [89]	6.00 [152]	.62 [16]	3.25 [82]	3.34 [85]	2.86 [73]	.62 † [16]	4.50 [114]	6.50 [165]	.41 [10]	5.88 [149]	3.62 [92]	.19 [5]	1.69 [43]
		3.75 * [95]													

OPTIONAL (WITH ADAPTOR PLATE)

MOTOR FRAMES 182TC, 184TC, 213C, 213TC, 215C, 215TC, 254C, AE90, AE100, AE112

* STANDARD DIMENSION

† 90° HOUSING

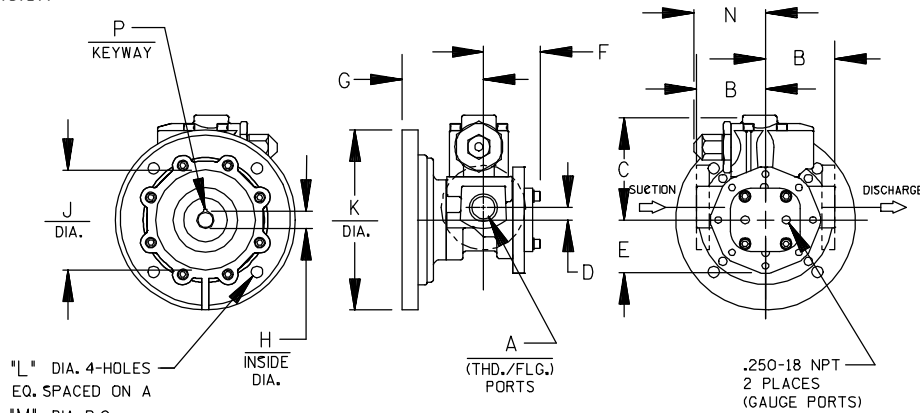

CAD FILE NO.: 16579

PUMP MODEL	PUMP DIMENSIONS - INCHES [MM]							PUMP MOUNTING DIMENSIONS							
	A	B	C	D	E	F	G	H	J	K	L	M	N	P	
GMC D [METRIC]	AE90 AE110/112	1"	† [64]	[132]	[16]	[68]	[69]	[117]	† [24]	[130]	[200]	[12]	[165]	[91]	[8] X [46]
			* [70]						[28]						
GMC G	1-1/2"	2"	† [89]	6.00 [152]	.62 [16]	3.25 [82]	3.34 [85]	4.62 [117]	† [1.12]	8.50 [216]	9.00 [229]	.53 [14]	7.25 [184]	3.62 [92]	.25 [6] X 2.12 [54]
			* [35]						[1.38]						
GMC G [METRIC]	AE90 AE110/112								[24] [28]	[130] [180]	[200] [250]	[12] [15]	[165] [215]		[8] X [46] [8] X [56]

THE GORMAN-RUPP COMPANY • MANSFIELD, OHIO

GORMAN-RUPP OF CANADA LIMITED • ST. THOMAS, ONTARIO, CANADA



DIRECT CLOSE COUPLED C-FLANGE DRIVE OPTION DIMENSIONS

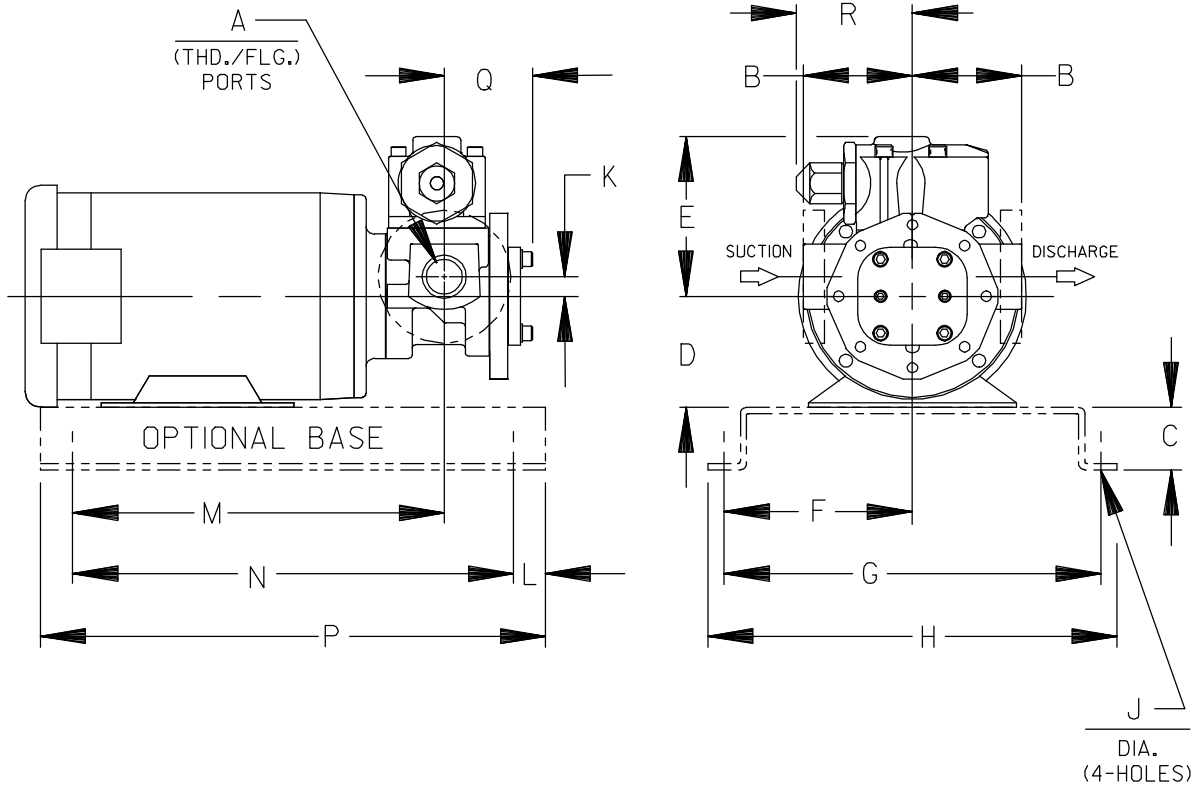

CAD FILE NO: 16503

PUMP MODEL	PUMP DIMENSIONS																		
	A	MOTOR FRAME	B	C	D	E	F	G	H	J	K	L	M	N	P	Q	R		
GMC D	1"	56C	2.50 † [64]	2.00 [51]	3.50* [89]	5.19 [132]	6.25 [159]	12.50 [318]	14.50 [368]	.56 [14]	.63 [16]	2.00 [51]	11.11 [282]	12.75 [324]	16.75 [425]	2.74 [70]	3.58 [91]		
		143TC/145TC	4.50 [114]		11.42 [290]														
		1820/184C	2.75* [70]		11.92 [303]														
GMC G	1-1/2"	56C	3.50 † [89]	2.00 [51]	3.50 [89]	6.00 [152]	6.25 [159]	12.50 [318]	14.50 [368]	.56 [14]	.63 [16]	2.00 [51]	11.18 [284]	12.75 [324]	16.75 [425]	3.34 [85]	3.62 [92]		
		143TC/145TC			4.50 [114]								11.49 [292]						
	2"	182C/184C	3.75* [95]	4.50 [114]	5.25 [133]	12.00 [305]	12.49 [317]	12.86 [327]	.56 [14]	.63 [16]	2.00 [51]	2.00 [51]	12.00 [305]	12.75 [324]	16.75 [425]	3.34 [85]	3.62 [92]		
		182TC/184TC																4.50 [114]	12.49 [317]
		213TC/215TC																5.25 [133]	12.86 [327]

* STANDARD DIMENSION

† 90° HOUSING



1 PHASE DIRECT CLOSE COUPLED C-FLANGE DRIVE OPTIONS

(Drive Assembly Number Is For Motor Only)

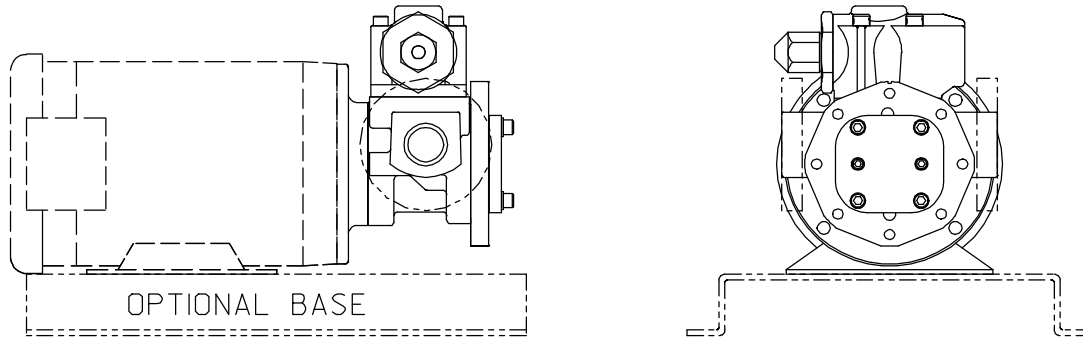

16503.S01

PUMP MODEL NUMBER	1 PHASE		FRAME	115/230 VOLTS DRIVE ASSY NO.		
	RPM	HP		OPEN	TEFC	EXPLOSION PROOF
GMC D/G	1750	.75	56C	91111-540	91121-540	91131-540
		1.00	56C	91111-542	91121-542	91131-542
		1.50	56C	91111-546	91121-546	91131-546
		1.50	184C (a)			91131-547
		2.00	145TC (a)	91111-550		91131-550
		2.00	184C (a)		91121-550	
	1140	.75	56C	91111-580	91121-580	91131-580

(a) REQUIRES OPTION 50A OR 50J

NOTE: CONSULT FACTORY FOR:

- | | |
|-----------------------------------|---|
| 1. HORSEPOWERS & FRAMES NOT SHOWN | 5. 50 HERTZ 380 VOLT MOTORS |
| 2. DRIP PAN BASES | 6. FOR OPTIONAL BASE SEE PRICE PAGES |
| 3. 115-208/230 VOLT MOTORS | 7. COUNTER-CLOCKWISE ROTATION FOR SINGLE PHASE MOTORS |
| 4. 208-230/460 VOLT MOTORS | |



3 PHASE DIRECT CLOSE COUPLED C-FLANGE DRIVE OPTIONS

(Drive Assembly Number Is For Motor Only)

PUMP MODEL NUMBER	3 PHASE		FRAME	230/460 VOLTS DRIVE ASSY NO.		
	RPM	HP		OPEN	TEFC	EXPLOSION PROOF
GMC D/G	1750	.75	56C	91141-540	91151-540	91161-540
		1.00	143TC (a)	91141-542		
		1.00	56C		91151-542	91161-542
		1.50	145TC (a)	91141-546		
		1.50	56C		91151-546	91161-546
		2.00	145TC (a)	91141-550	91151-550	
		2.00	56C			91161-550
		3.00	145TC (a)	91141-554		
		3.00	56C		91151-554	
GMC G	1750	5.00	184C (a)	91141-558	91151-558	
		3.00	182TC (b)			91161-554
		5.00	184TC (b)			91161-558
		7.50	213TC (c)	91141-572	91151-572	91161-572
GMC D/G	1150	10.00	215TC (c)	91141-576	91151-576	91161-576
		.75	56C	91141-580	91151-580	91161-580
		1.00	56C	91141-582	91151-582	91161-582
		1.00	56C	91141-586		
		1.50	145TC (a)		91151-586	91161-586
		1.50	182C (a)			91161-588
GMC G	1150	2.00	184C (a)		91151-590	91161-590
		2.00	184TC (b)	91141-700	91141-700	
		3.00	213TC (c)	91141-704	91151-704	91161-704
GMC D	850	5.00	215TC (c)	91141-708	91151-708	91161-708
		.75	184C (a)		91151-720	
GMC G	850	1.00	182TC (b)	91141-730	91151-730	
		1.50	184TC (b)	91141-734	91151-734	
		2.00	213TC (c)	91141-738	91151-738	
		3.00	215TC (c)	91141-742	91151-742	

- (a) REQUIRES OPTION 50A OR 50J
- (b) REQUIRES OPTION 70A AND 50B OR 50K
- (c) REQUIRES OPTION 70A AND 50C OR 50L

NOTE: CONSULT FACTORY FOR:

- | | |
|-----------------------------------|---|
| 1. HORSEPOWERS & FRAMES NOT SHOWN | 5. 50 HERTZ 380 VOLT MOTORS |
| 2. DRIP PAN BASES | 6. FOR OPTIONAL BASE SEE PRICE PAGES |
| 3. 115-208/230 VOLT MOTORS | 7. COUNTER-CLOCKWISE ROTATION FOR SINGLE PHASE MOTORS |
| 4. 208-230/460 VOLT MOTORS | |



GRR REDUCER CLOSE COUPLED C-FLANGE DRIVE OPTION DIMENSIONS

(Drive Assembly Number Includes Gear Reducer and Base, But **NOT** the Motor)

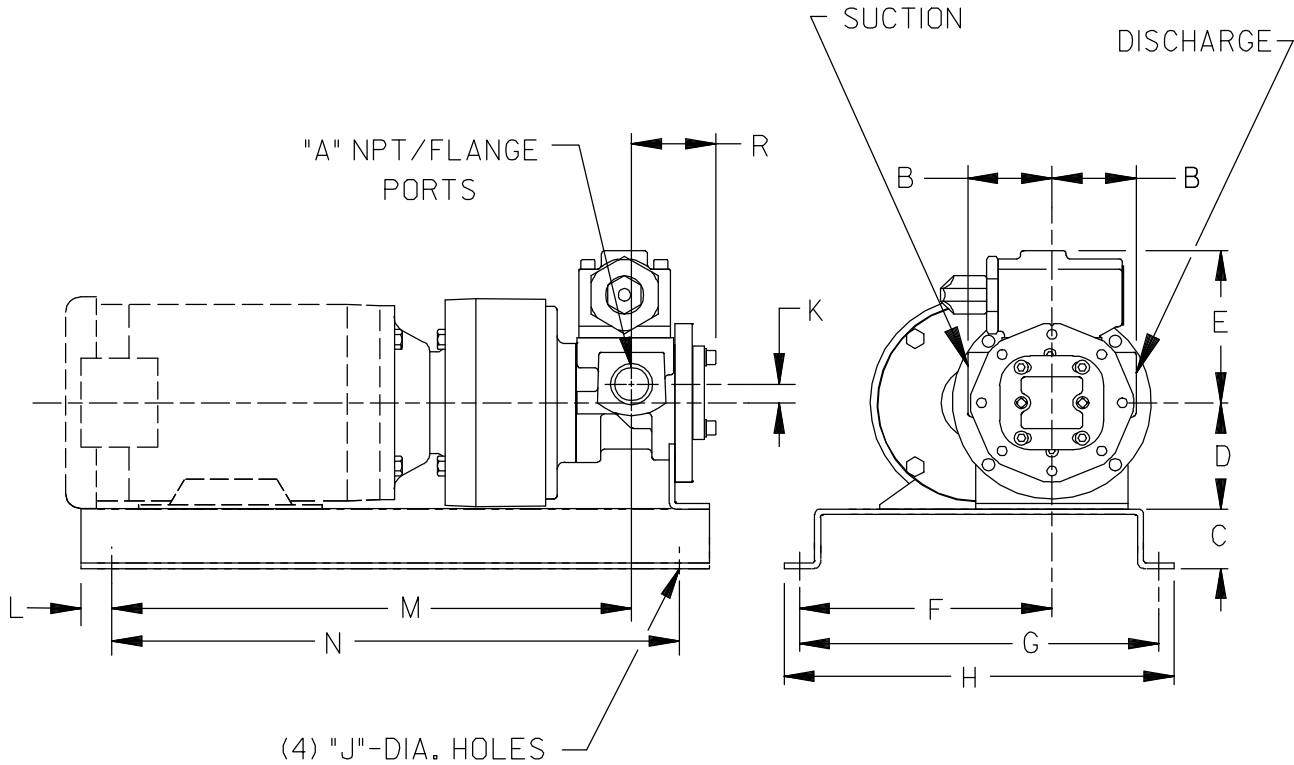

CAD FILE NO.: 16390B

PUMP MODEL	UNIT DIMENSIONS														
	"A"	MOTOR FRAME	B	C	D	E	F	G	H	J	K	L	M	N	R
GMC D	1"	56C	2.50 † [70]	2.00 [51]	3.50 [89]	5.19 [132]	6.50 [165]	13.00 [330]	15.00 [381]	.56 [14]	.63 [16]	3.00 [76]	14.22 [361]	25.50 [648]	2.66 [68]
		143TC/145TC	2.75* [70]		4.50 [114]										
GMC G	1 1/2"	56C	3.50 † [89]	2.00 [51]	3.50 [89]	6.00 [152]	6.50 [165]	13.00 [330]	15.00 [381]	.56 [14]	.63 [16]	3.00 [76]	14.16 [360]	25.50 [648]	3.27 [83]
		143TC/145TC	3.75* [95]		4.50 [114]										
		184C													

* STANDARD DIMENSION

† 90° HOUSING



GMC

GRR REDUCER CLOSE COUPLED C-FLANGE DRIVE OPTIONS

(Drive Assembly Number Includes Gear Reducer and Base, But **NOT** the Motor)

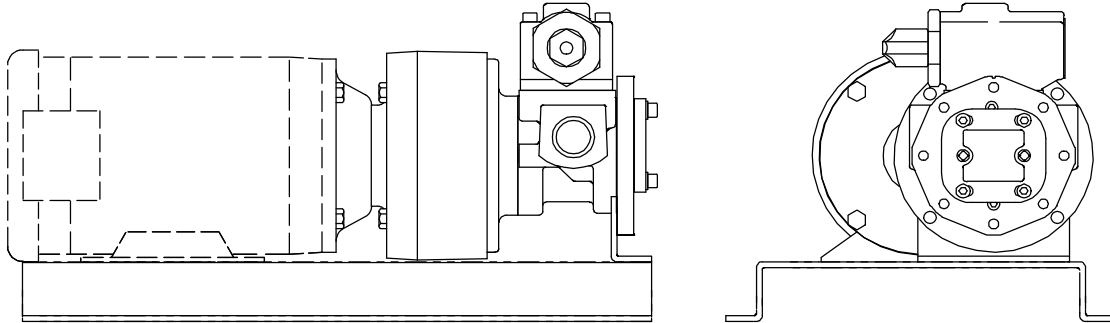

PUMP MODEL NUMBER	RPM @ 1750	RPM @ 1150	REDUCER ①		FRAME	DRIVE ASSY NO.	
			MAX HP @ 1750	MAX HP @ 1150			
GMC D ②	875	575	2.00:1	5.65	3.73	56C	90153-510
				11.70	7.72	143TC/145TC	90153-519
				11.70	7.72	182C/184C	90153-522
	580	383	3.00:1	3.76	2.48	56C	90123-533
				8.10	5.35	143TC/145TC	90153-536
				8.10	5.35	182C/184C	90153-542
	440	288	4.00:1	2.82	1.86	56C	90153-550
				5.90	3.89	143TC/145TC	90153-553
				5.90	3.89	182C/184C	90153-559
	350	238	5.00:1	2.26	1.49	56C	90153-570
				5.20	3.43	143TC/145TC	90153-573
				5.20	3.43	182C/184C	90153-579
GMC G ②	875	575	2.00:1	5.65	3.73	56C	90153-610
				11.70	7.72	143TC/145TC	90153-613
				11.70	7.72	182C/184C	90153-629
	580	383	3.00:1	3.76	2.48	56C	90153-630
				8.10	5.35	143TC/145TC	90153-633
				8.10	5.35	182C/184C	90123-642
	440	288	4.00:1	2.82	1.86	56C	90153-660
				5.90	3.89	143TC/145TC	90153-663
				5.90	3.89	182C/184C	90153-672
	350	238	5.00:1	2.26	1.49	56C	90153-690
				5.20	3.43	143TC/145TC	90153-693
				5.20	3.43	182C/184C	90153-702

① Listed reducer horsepower rated for Standard Service (8-10 hrs/day). For Light Service (3-5 hrs/day) multiply maximum rated horsepower by 1.1. For Heavy Service (16-24 hrs/day) multiply maximum rated horsepower by 0.9.

② Use adds/deletes for large diameter head and coverplate kit if required.

NOTES:
CONSULT FACTORY FOR:
HORSEPOWERS AND FRAMES NOT SHOWN.
DRIP PAN BASES.



PERFORMANCE CURVES

SPEED VS. CAPACITY/HORSEPOWER

GJ

Hydraulic
Size

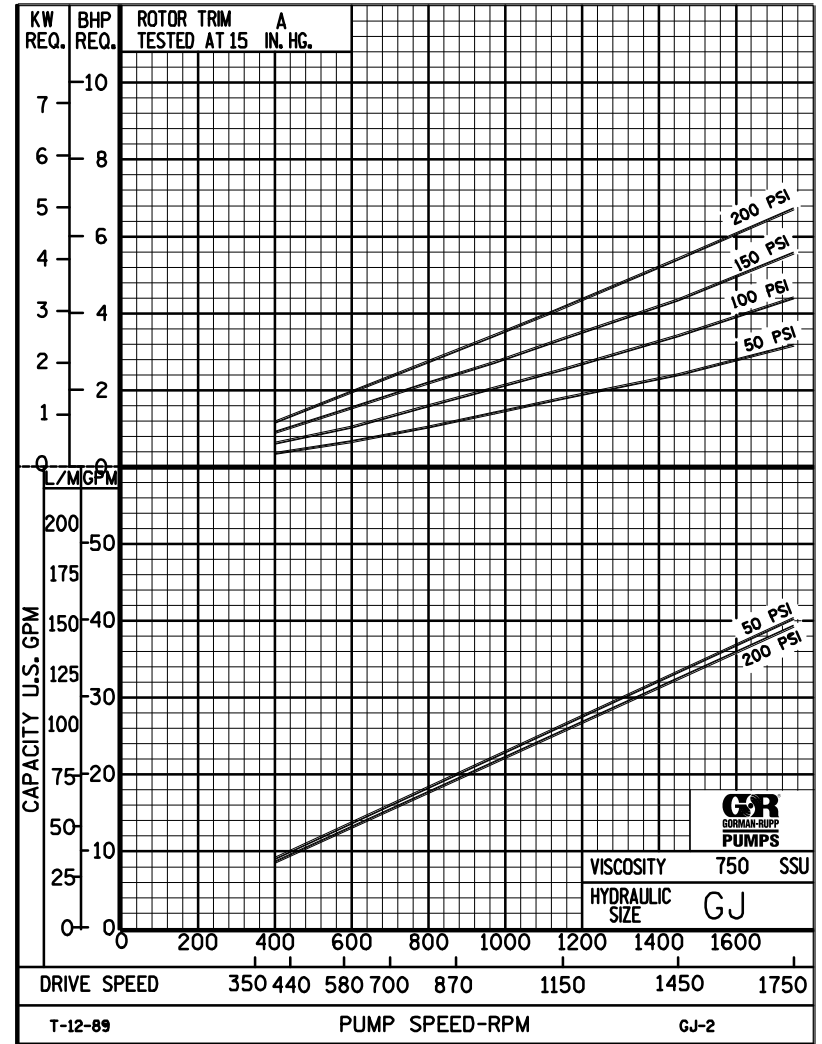
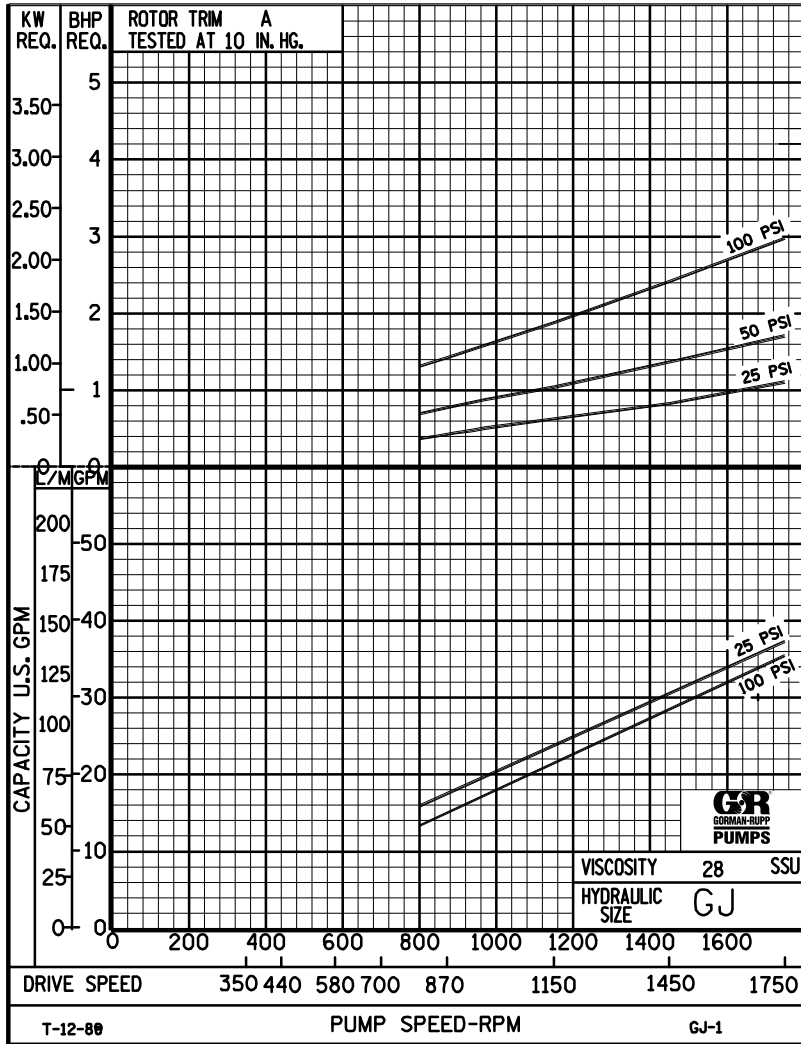

THE GORMAN-RUPP COMPANY • MANSFIELD, OHIO
 GORMAN-RUPP OF CANADA LIMITED • ST. THOMAS, ONTARIO, CANADA

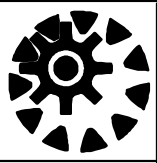

PERFORMANCE CURVES

SPEED VS. CAPACITY/HORSEPOWER

GJ Hydraulic Size

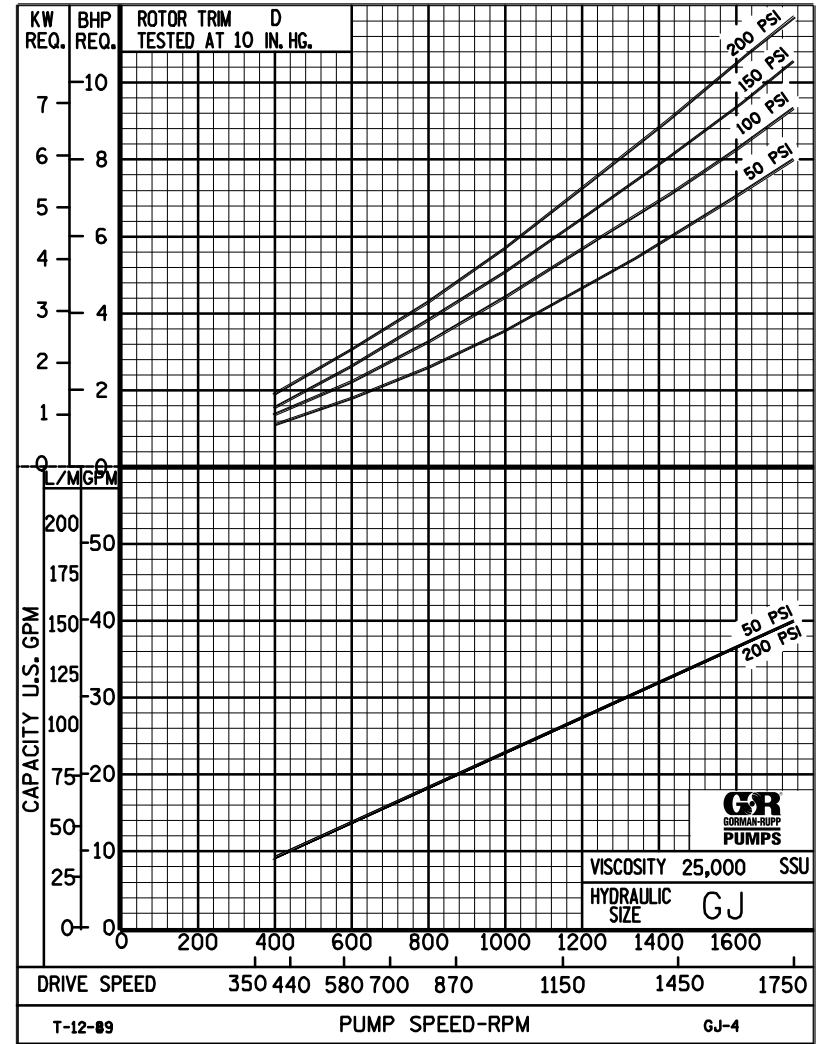
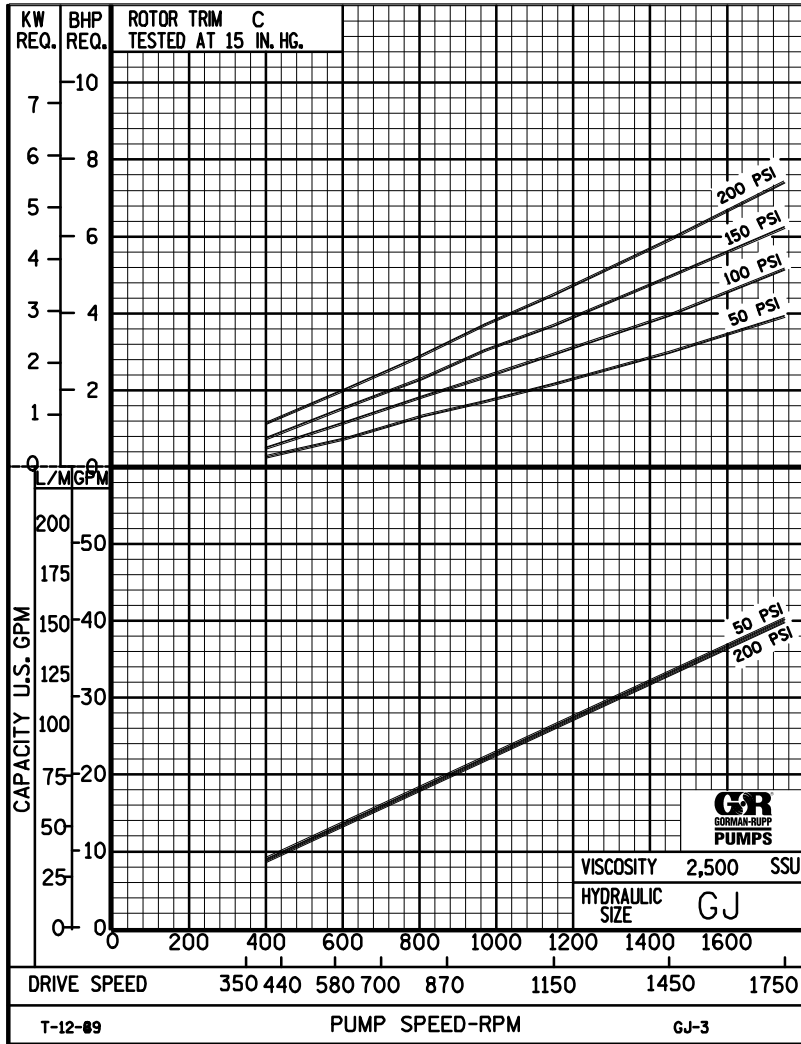

THE GORMAN-RUPP COMPANY • MANSFIELD, OHIO
 GORMAN-RUPP OF CANADA LIMITED • ST. THOMAS, ONTARIO, CANADA



GJ

PUMP HYDRAULIC SIZE CHART

SEC. 500

Page 58

January 2010

**38 GPM
1750 RPM**

NOMINAL		ROTOR TRIM	VISCOSITY (SSU)	N.I.P.R. (PSIA)	FRICTION PIPE LOSS (PSI/FT) <small>(Based on Sch 40 Steel Pipe)</small>					FULL BYPASS RELIEF VALVE PRESSURE (PSI)					CAPACITY (GPM) / H.P. REQUIRED								
CAP. GPM	SPEED RPM				PIPE DIAMETER					CRACKING PRESS. (PSI)					DIFFERENTIAL PRESSURE (PSI)								
					3/4"	1"	1 1/4"	1 1/2"	2"	LOW PRES R/V			HI PRES R/V		MEDIUM DUTY AND HEAVY DUTY				HEAVY DUTY ONLY				
							50	75	100	150	200	25	50	75	100	150	200	300	400				
38	1750	STD	28	4.5	.02	.01	.01	.01	.01	74	100	127				37	36	36	35				
			32		.88	.28	.08	.04	.01							1.1	1.7	2.4	3.0				
			38	4.5	1.12	.35	.10	.05	.02	74	100	128	180			38	37	37	37	36			
			50		1.33	.44	.12	.06	.02							1.5	2.0	2.6	3.2	4.5			
			70	4.5	1.45	.46	.13	.06	.02	76	101	128	182	240		39	38	38	38	37	36		
			100		1.74	.56	.16	.08	.03							1.5	2.1	2.8	3.4	4.7	6.0		
			150	4.5	1.91	.63	.17	.08	.03	78	103	130	184	242		39	39	39	38	38	38		
			200		2.26	.72	.18	.09	.03							1.9	2.5	3.1	3.7	4.9	6.1		
			300	4.5	2.45	.81	.19	.10	.04	78	103	132	184	244		40	40	39	39	39	38		
			500		2.82	.92	.31	.17	.06							2.1	2.8	3.6	4.3	5.4	6.5		
		750	4.5	3.64	1.39	.46	.25	.09	80	105	134	186	246		40	40	40	40	39	39			
		1,000		4.85	1.85	.62	.33	.12							2.3	3.2	3.8	4.4	5.6	6.7			
		2,000	5.9	9.69	3.69	1.23	.67	.25	80	105	136	186	247		40	40	40	40	39	39			
		3,500		17.0	6.46	2.16	1.17	.43							3.3	3.9	4.6	5.1	6.3	7.4			
		5,000	6.8	24.3	9.23	3.08	1.66	.61	86	106	136	186	247		40	40	40	40	40	40			
		7,500		36.4	13.9	4.62	2.50	.92							4.8	5.3	5.9	6.5	7.6	8.8			
		10,000	7.7	48.5	18.5	6.16	3.33	1.23	92	117	142	192	247		40	40	40	40	40	40			
		15,000		72.7	27.7	9.24	4.99	1.84							6.0	6.7	7.2	7.8	9.0	10			
		20,000	8.5	97.0	36.9	12.3	6.65	2.45	98	123	148	198	248		40	40	40	40	40	40			
		25,000		121	46.1	15.4	8.31	3.06							7.4	8.0	8.7	9.4	11	12			
50,000																							
75,000																							
100,000																							
150,000																							
200,000																							
250,000																							

(NOTE) For speeds not shown on the pump hydraulic charts, consult factory.



GJ

PUMP HYDRAULIC SIZE CHART

SEC. 500

Page 59

January 2010

**25 GPM
1150 RPM**

NOMINAL		ROTOR TRIM	VISCOSITY (SSU)	N.I.P.R. (PSIA)	FRICTION PIPE LOSS (PSI/FT) <small>(Based on Sch 40 Steel Pipe)</small>					FULL BYPASS RELIEF VALVE PRESSURE (PSI)					CAPACITY (GPM) / H.P. REQUIRED											
CAP. GPM	SPEED RPM				PIPE DIAMETER					CRACKING PRESS. (PSI)					DIFFERENTIAL PRESSURE (PSI)											
					3/4"	1"	1 1/4"	1 1/2"	2"	LOW PRES R/V			HI PRES R/V		MEDIUM DUTY AND HEAVY DUTY				HEAVY DUTY ONLY							
25	1150	STD	28	2.5	.01	.01	.01	.01	.01	66	92	118			23	23	22	21								
			32		.42	.13	.04	.02	.01						.63	1.0	1.5	1.9								
			38	2.5	.53	.17	.05	.02	.01	66	92	118	170			24	24	23	22	21						
			50		.64	.21	.06	.03	.01							.95	1.2	1.6	2.0	2.6						
			70	2.5	.70	.23	.06	.03	.01	67	93	120	170	230			25	25	24	23	23	22				
			100		.85	.27	.08	.04	.01								1.2	1.4	1.7	2.1	3.0	3.7				
			150	2.5	.94	.32	.08	.04	.01	67	93	122	172	232			26	26	25	24	24	22				
			200		.97	.35	.10	.06	.02								1.3	1.5	1.9	2.3	3.1	3.8				
			300	2.5	.99	.37	.13	.07	.03	68	95	122	174	234			26	26	25	25	25	24				
			500		1.60	.61	.21	.11	.04								1.3	1.7	2.3	2.5	3.5	4.0				
		750	2.5	2.39	.91	.31	.17	.06	68	95	124	174	235			26	26	26	26	25	25					
		1,000		3.19	1.22	.41	.22	.08								1.3	1.8	2.2	2.5	3.3	4.2					
		2,000	3.4	6.38	2.43	.81	.44	.16	69	98	125	175	235			26	26	26	26	26	26					
		3,500		11.2	4.25	1.42	.77	.28								1.8	2.3	2.8	3.2	3.9	4.7					
		5,000	4.0	16.0	6.07	2.03	1.09	.41	78	105	130	180	237			26	26	26	26	26	26					
		7,500		23.9	9.10	3.04	1.64	.61								2.4	2.9	3.4	3.7	4.7	5.2					
		10,000	4.7	31.9	12.2	4.06	2.19	.81	87	112	137	187	237			26	26	26	26	26	26					
		15,000		47.8	18.2	6.08	3.28	1.21								2.9	3.7	4.2	4.5	5.4	6.0					
		20,000	5.2	63.8	24.3	8.11	4.38	1.61	87	112	137	187	237			26	26	26	26	26	26					
		25,000		79.7	30.4	10.2	5.47	2.02								4.0	4.5	4.9	5.3	6.1	6.8					
50,000																										
75,000																										
100,000																										
150,000																										
200,000																										
250,000																										

(NOTE) For speeds not shown on the pump hydraulic charts, consult factory.



GJ

PUMP HYDRAULIC SIZE CHART

SEC. 500

Page 60

January 2010

**19 GPM
870 RPM**

NOMINAL		ROTOR TRIM	VISCOSITY (SSU)	N.I.P.R. (PSIA)	FRICTION PIPE LOSS (PSI/FT) <small>(Based on Sch 40 Steel Pipe)</small>					FULL BYPASS RELIEF VALVE PRESSURE (PSI)					CAPACITY (GPM) / H.P. REQUIRED											
CAP. GPM	SPEED RPM				PIPE DIAMETER					CRACKING PRESS. (PSI)					DIFFERENTIAL PRESSURE (PSI)											
					3/4"	1"	1 1/4"	1 1/2"	2"	LOW PRES R/V			HI PRES R/V		MEDIUM DUTY AND HEAVY DUTY				HEAVY DUTY ONLY							
19	870	STD	28	1.7	.01	.01	.01	.01	.01	64	90	116			17	16	16	15								
			32		.26	.08	.02	.01	.01						.45	.79	1.1	1.4								
			38	1.7	.33	.11	.03	.02	.01	64	90	116	168			18	17	17	16	15						
			50		.40	.13	.04	.02	.01							.58	.81	1.1	1.5	2.2						
			70	1.7	.44	.14	.04	.02	.01	65	91	118	168	228			19	18	18	17	17	16				
			100		.53	.17	.05	.02	.01								.61	.85	1.3	1.6	2.4	2.7				
			150	1.7	.58	.19	.06	.03	.01	65	91	120	170	230			19	19	18	18	18	17				
			200		.62	.23	.08	.04	.01								.65	.90	1.4	1.6	2.6	3.0				
			300	1.7	.74	.28	.10	.05	.02	66	93	120	172	232			19	19	19	19	18	18				
			500		1.21	.46	.16	.09	.03								.77	1.1	1.4	1.7	2.7	3.1				
		750	1.7	1.82	.69	.23	.13	.05	66	93	122	172	233			20	20	19	19	19	19					
		1,000		2.43	.92	.31	.17	.06								.81	1.3	1.6	1.9	2.9	3.3					
		2,000	2.5	4.85	1.85	.62	.33	.12	67	96	123	173	233			20	20	20	19	19	19					
		3,500		8.48	3.23	1.08	.58	.22								1.2	1.5	1.9	2.1	3.1	3.4					
		5,000	3.1	12.1	4.61	1.54	.83	.31	76	103	128	178	235			20	20	20	20	19	19					
		7,500		18.2	6.92	2.31	1.25	.46								1.6	2.0	2.3	2.6	3.5	3.8					
		10,000	3.7	24.3	9.23	3.08	1.66	.61	85	110	135	185	235			20	20	20	20	19	19					
		15,000		36.4	13.9	4.62	2.50	.92								2.1	2.5	2.9	3.3	3.9	4.4					
		20,000	4.1	48.5	18.5	6.16	3.33	1.23	85	110	135	185	235			19	19	19	19	19	19					
		25,000		60.6	23.1	7.70	4.16	1.53								2.8	2.9	3.2	3.6	4.1	5.0					
50,000	4.5	121	46.2	15.4	8.32	3.06	85	114	141	193	246			19	19	19	19	19	19							
75,000		-	-	-	-	-								3.7	4.1	4.5	4.9	5.2	5.6							
100,000																										
150,000																										
200,000																										
250,000																										

(NOTE) For speeds not shown on the pump hydraulic charts, consult factory.

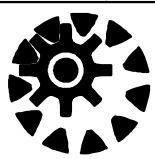

GJ

PUMP HYDRAULIC SIZE CHART

SEC. 500

Page 61

January 2010

**13 GPM
580 RPM**

NOMINAL		ROTOR TRIM	VISCOSITY (SSU)	N.I.P.R. (PSIA)	FRICTION PIPE LOSS (PSI/FT) <small>(Based on Sch 40 Steel Pipe)</small>					FULL BYPASS RELIEF VALVE PRESSURE (PSI)					CAPACITY (GPM) / H.P. REQUIRED											
CAP. GPM	SPEED RPM				PIPE DIAMETER					CRACKING PRESS. (PSI)					DIFFERENTIAL PRESSURE (PSI)											
					3/4"	1"	1 1/4"	1 1/2"	2"	LOW PRES R/V			HI PRES R/V		MEDIUM DUTY AND HEAVY DUTY				HEAVY DUTY ONLY							
13	580	STD	28	1.2	.01	.01	.01	.01	.01	58	84	109			11	11	10	10								
			32		.13	.04	.01	.01	.01						.36	.60	.81	1.0								
			38	1.2	.17	.06	.02	.01	.01	58	84	109	159			12	11	11	11	10						
			50		.21	.07	.02	.01	.01							.47	.63	.93	1.2	1.7						
			70	1.2	.23	.08	.03	.01	.01	60	86	111	161	219			12	12	12	11	11	10				
			100		.28	.09	.03	.01	.01								.50	.69	.99	1.3	1.8	2.0				
			150	1.2	.34	.11	.04	.02	.01	60	86	111	162	220			13	12	12	12	12	11				
			200		.43	.15	.06	.03	.01								.57	.80	1.1	1.3	1.8	2.1				
			300	1.2	.52	.20	.07	.04	.01	62	88	113	164	222			13	13	13	12	12	12				
			500		.83	.34	.11	.06	.02								.66	.92	1.2	1.4	1.8	2.2				
		750	1.2	1.26	.49	.16	.09	.03	62	88	113	164	222			13	13	13	13	12.9	12					
		1,000		1.68	.65	.21	.12	.05								.74	1.1	1.3	1.5	1.9	2.2					
		2,000	1.9	3.23	1.32	.44	.24	.09	63	90	115	165	223			13	13	13	13	12	12					
		3,500		6.10	2.31	.77	.42	.16								.92	1.3	1.5	1.7	2.1	2.2					
		5,000	2.4	8.25	3.28	1.11	.58	.23	67	92	117	165	223			13	13	13	13	13	13					
		7,500		13.1	5.01	1.61	.89	.33								1.2	1.7	1.9	2.1	2.5	2.9					
		10,000	2.9	17.8	6.85	2.22	1.21	.45	70	96	120	166	224			13	13	13	13	13	13					
		15,000		25.2	9.90	3.41	1.83	.68								1.4	1.7	2.0	2.2	2.6	3.0					
		20,000	3.3	34.4	13.0	4.33	2.28	.91	74	99	122	166	224			13	13	13	13	13	13					
		25,000		45.3	16.8	5.54	3.01	1.11								1.6	1.8	2.1	2.3	2.7	3.1					
50,000	5.5	85.2	32.6	11.2	6.22	2.21	84	109	132	176	234			13	13	13	13	13	13							
75,000		132	48.8	16.9	9.31	3.28								2.4	2.6	2.9	3.1	3.6	3.9							
100,000																										
150,000																										
200,000																										
250,000																										

(NOTE) For speeds not shown on the pump hydraulic charts, consult factory.



GJ

SEC. 500

PAGE 61.1

February 2025

5 GPM
200 RPM

NOMINAL		VISCOSITY		N.I.P.R	FRICTION PIPE LOSS (PSI/FT) <small>(Schedule 40 Steel Pipe)</small>					CAPACITY (GPM)				H.P. REQUIRED							
GPM	RPM	ROTOR TRIM	(SSU)	(PSIa)	PIPE DIAMETER					MEDIUM-DUTY & HEAVY-DUTY				HEAVY-DUTY ONLY							
					1½"	2"	2½"	3"	4"	DIFFERENTIAL PRESSURE (PSI)											
										25	50	75	100	150	200	300	400				
5	200	STD																			
				"D"	200,000	2.6	8.8	3.2	1.6	0.7	0.2	4.6	4.6	4.6	4.6	4.5	4.5	4.5	4.5		
			399,999		17.5		6.5	3.2	1.3	0.5	1.2	1.2	1.2	1.3	1.5	1.6	1.9	2.2			
			400,000			2.9					NR	9.7	4.8	2	0.7	4.6	4.6	4.6	4.6	4.5	4.5
			599,999		3.6		NR	12.9	6.3	2.7						0.9	1.4	1.4	1.4	1.5	1.7
			600,000			4					NR	16.1	7.9	3.3	1.1		4.6	4.6	4.6	4.6	4.5
			799,999		NR		16.1	7.9	3.3	1.1						1.9	1.9	1.9	2.0	2.2	2.3
			800,000																		
	1M																				

(NOTE) For speeds not shown on the pump hydraulic charts, consult factory.