

**SF Series**<sup>®</sup>  
VARIOUS PATENTS APPLY

Solids Handling Electric Motor Driven  
**Submersible Pump**  
Models  
**SF6F & SF6F-X**  
Size 6"



**APPROVED**  
X-PROOF MOTORS FOR CLASS I,  
DIV. 1, GROUPS C&D LOCATIONS  
(X-Proof Version Only)

The Gorman-Rupp SF Series<sup>®</sup> channel pumps provide superior pumping efficiency while maintaining a 3-inch (76,2 mm) spherical solids passage.

**Key Features:**

- NEMA premium efficiency motors
- Externally adjustable face clearance
- Press-fit motor with finned motor housing provides superior motor cooling, even in a submersed state, resulting in increased motor life
- NEMA Class H motor insulation
- Direct wired power cable leads
- Standard moisture detection in both the seal and motor chambers
- Factory Mutual (FM) Approved for Class I, Division I, Group C and D Haz Loc Applications (X-Proof Model)



**Optional Accessories:**

- G-R Hard Iron Impeller
- Control Panel (Consult [SF Series Motor Data Reference](#) for Customer-Supplied Control Panel)
- Submersible Transducer or Ball Type Float Switches
- Slide Rail Installation Components
  - Guide shoe <sup>W</sup>/Rubber Seal
  - Base Elbow and Rail Brackets
- Trash Stand Installation Components
  - Trash Stand
  - Discharge Elbow

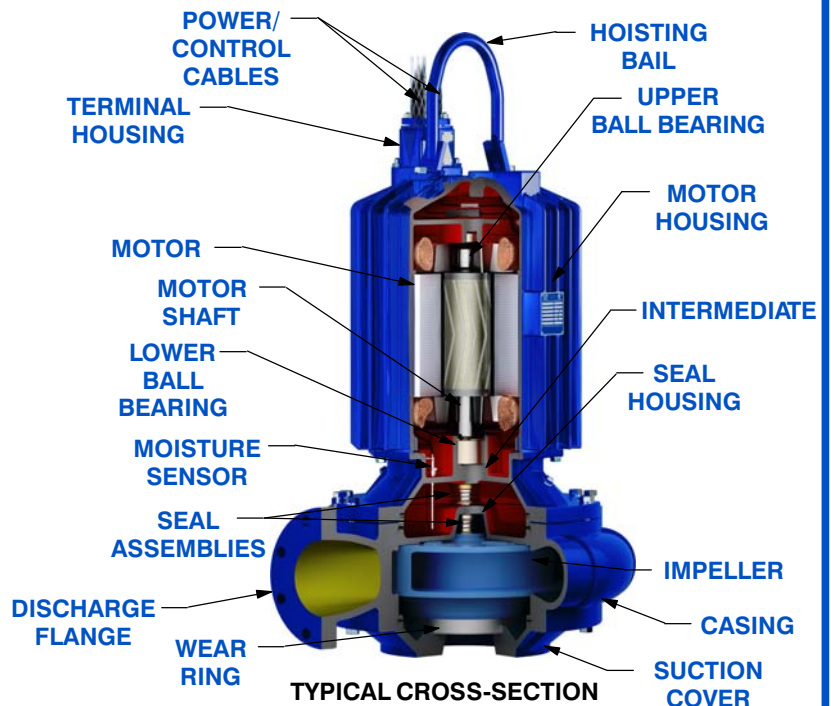

**GORMAN-RUPP PUMPS**

www.grpumps.com

Specifications Subject to Change Without Notice

Printed in U.S.A.

**PUMP DETAILS**

Pump Model	SF6F & SF6F-X	
Agency Approvals	Consult Factory	
Discharge Flange	6" ANSI w/ Flat Face	
Impeller Type / Material	Single Vane Enclosed / Ductile Iron	
Wear Ring Material	Ductile Iron	
Spherical Solids Handling	3" (76 mm) Non-Deformable Diameter	
Motor Housing (Including Seal Plate and Intermediate)	Gray Iron 30	
Pump Casing	Ductile Iron	
Motor Shaft	17-4 PH Stainless Steel	
O-Rings	Buna-N and Fluorocarbon (DuPont Viton® or Equivalent)	
Bearings: Type/Lubrication	Upper	Single Row Ball/Permanent Lubrication
	Lower	Double Row Ball/Permanent Lubrication
External Hardware	303/304 Stainless Steel	
External Surface Protection	Epoxy Paint	
Seal Type	Tandem, Mechanical, Oil Lubricated Upper, Self-Lubricated Lower	
Sealing Faces: Rotating/Stationary	Upper	Carbon/Ni-Resist
	Lower	Silicon Carbide/Silicon Carbide
Seal Elastomers	Buna-N Upper, Fluorocarbon (DuPont Viton® or Equivalent) Lower	
Max. Liquid Temperature	104°F (40°C)	

**MOTOR DETAILS**

Speed	60 Hz, 1750 RPM	
Motor Design	Inverter-Duty Rated, Air-Filled Enclosure, Squirrel Cage, Induction Start	
Motor Efficiency Rating	NEMA Premium Efficiency (IEC IE3)	
Insulation	Class H, Rated 356°F (180°C)	
Max. Submergence	65 Feet (20 Meters)	
Min. Submergence	1/2 Motor Covered	
Max. Starts per Hour	10	
Max. Rated Output Power	30.0 HP (22,4 kW)	
Amp Draw @ Max. Rated Power: Full Load/ Locked Rotor	230V/3P	73.2/492
	460V/3P	36.6/246
	575V/3P	29.3/197
NEMA Motor Code	H	
Service Factor	1.15	
Efficiency: 100%/75%/50% Load	90%/91%/90%	
Power Factor: 100%/75%/50% Load	0.83/0.78/0.67	
Field Connection	Across-the-Line	
Moisture Sensor	Single Probe Monitoring Both Seal and Motor Chambers	
Thermal Overload	One Thermostat per Phase, Self-Resetting	

**CABLE DETAILS**

Power Cable	Voltage	230/460V	575V
	No. Cables/Conductors per	1/6	1/6
	Gauge	(3) 6 AWG PWR & (3) 10 AWG GND/GC	(3) 8 AWG PWR & (3) 10 AWG GND/GC
	Type/Material	GGC/CPE	GGC/CPE
Control Cable	Nominal Cable O.D.	1.19" (30,2 mm)	0.97" (24,6 mm)
	No. Cables/Conductors per	1/4	
	Gauge	14 AWG	
	Type/Material	SOOW/CPE	
	Nominal Cable O.D.	0.61" (15,5 mm)	
Length	32 Feet (10 Meters) Standard, 164 Feet (50 Meters) Maximum		



**GORMAN-RUPP PUMPS**

www.grpumps.com

Specifications Subject to Change Without Notice

Printed in U.S.A.

**Specification Data**

SECTION 133, PAGE 360.2

**MODEL SF6F & SF6F-X  
SLIDE RAIL VERSION  
APPROXIMATE  
DIMENSIONS and WEIGHTS**

**NET WT:** (pump only) **1294 LBS.** [586,9 KG.]  
(comb. cable wt. per meter [3.2 ft.]) **3.4 LBS.** [1,54 KG.]  
**SHIPPING WT:** (pump only) **1444 LBS.** [655 KG.]  
**CRATE SIZE:** **23.2 CU. FT.** [0,66 CU. M.]

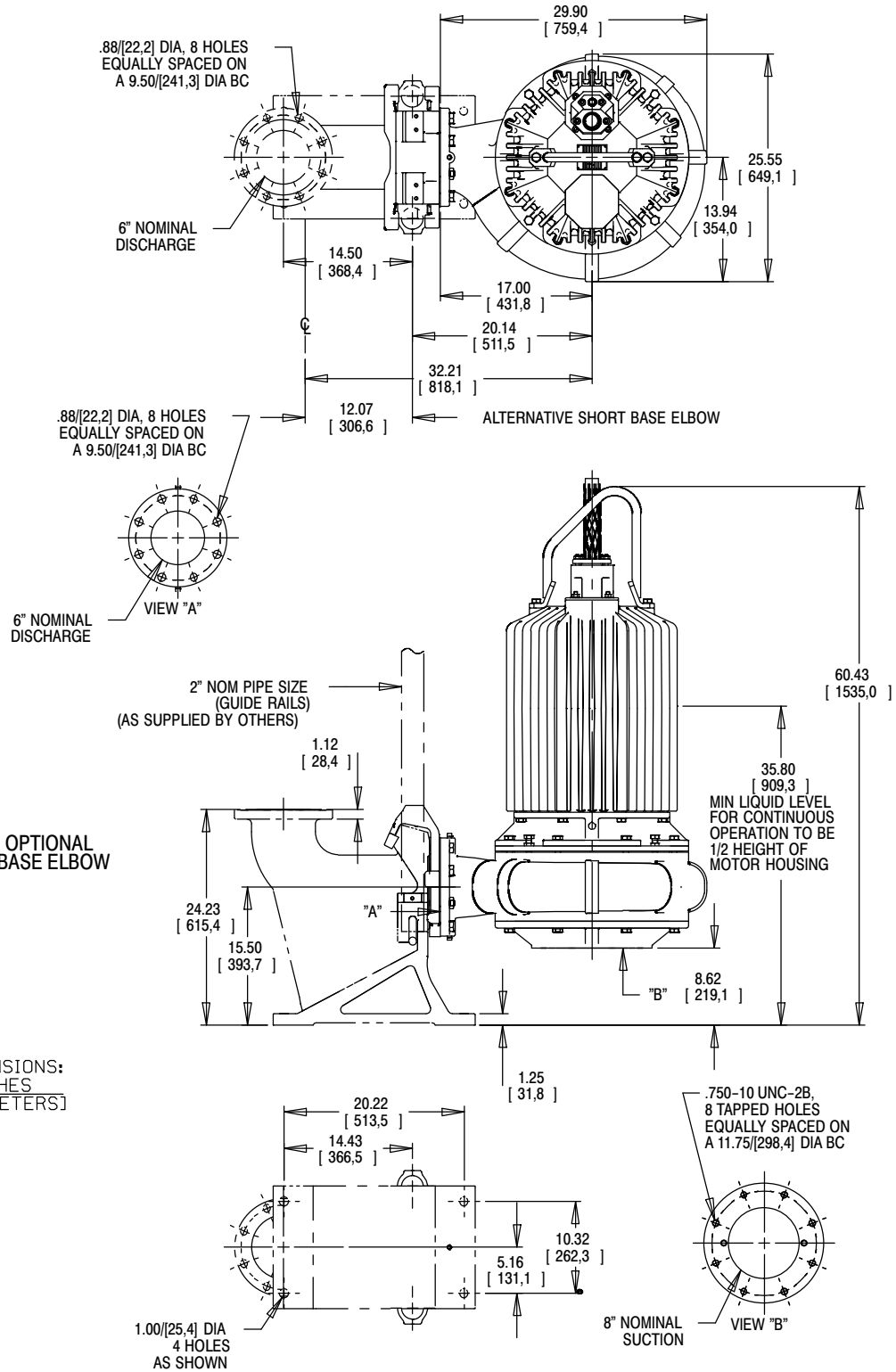

DIMENSIONS:  
INCHES  
(MILLIMETERS)



**GORMAN-RUPP PUMPS**

www.grpumps.com

Specifications Subject to Change Without Notice

Printed in U.S.A.

**Specification Data**

SECTION 133, PAGE 360.3

**MODEL SF6F & SF6F-X  
TRASH VERSION  
APPROXIMATE  
DIMENSIONS and WEIGHTS**

**NET WT:** (pump only) **1354 LBS.** [614,2 KG.]  
 (comb. cable wt. per meter [3.2 ft.]) **3.4 LBS.** [1,54 KG.]  
**SHIPPING WT:** (pump only) **1499 LBS.** [680 KG.]  
**CRATE SIZE:** **26.5CU. FT.** [0,75 CU. M.]

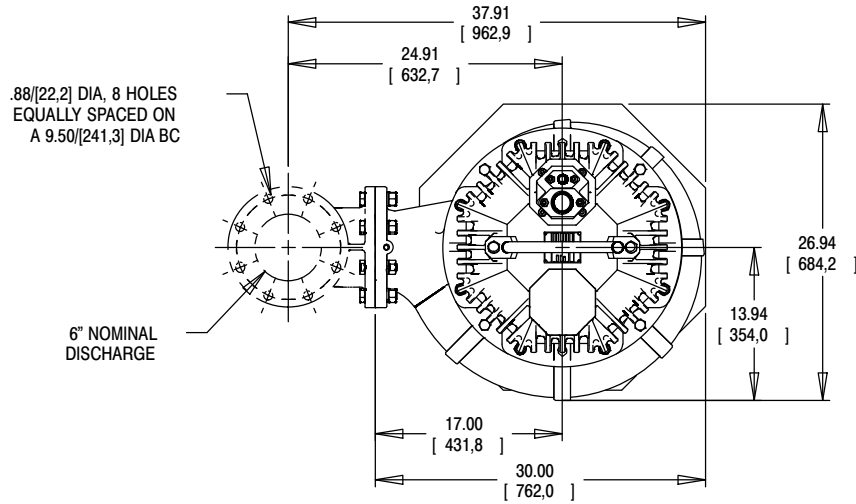

**PUMP WITH TRASH STAND  
SHOWN WITH OPTIONAL  
DISCHARGE ELBOW**

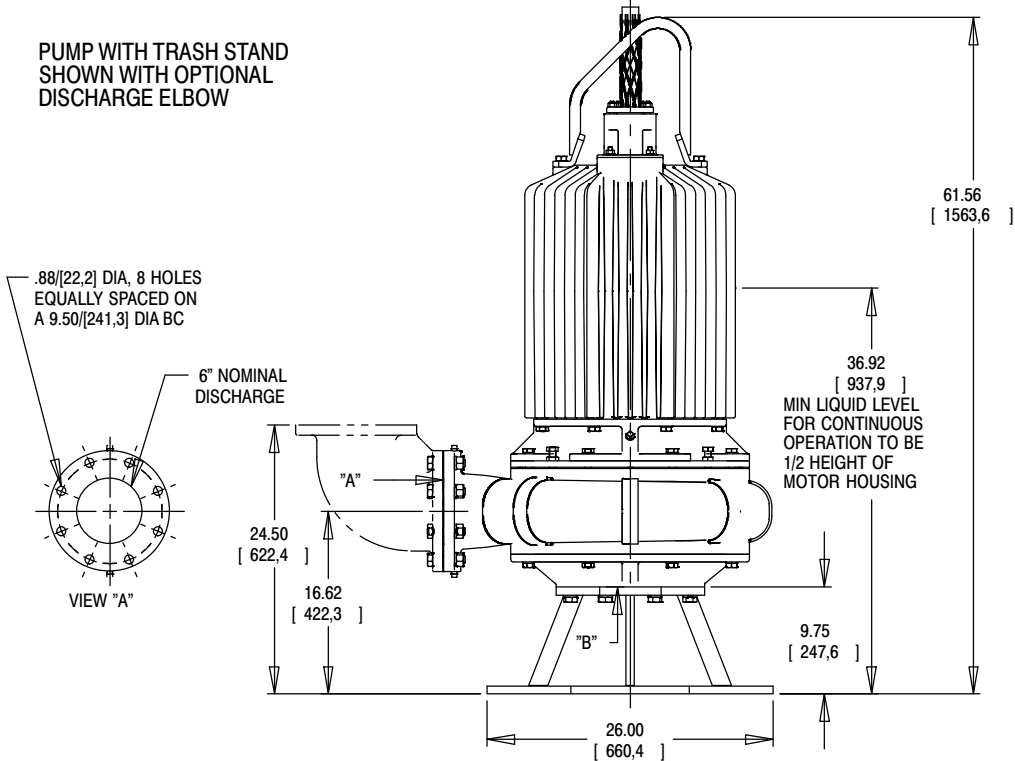

DIMENSIONS:  
INCHES  
[MILLIMETERS]

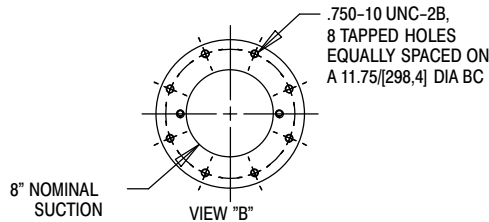

**GORMAN-RUPP PUMPS**

www.grpumps.com

Specifications Subject to Change Without Notice

Printed in U.S.A.

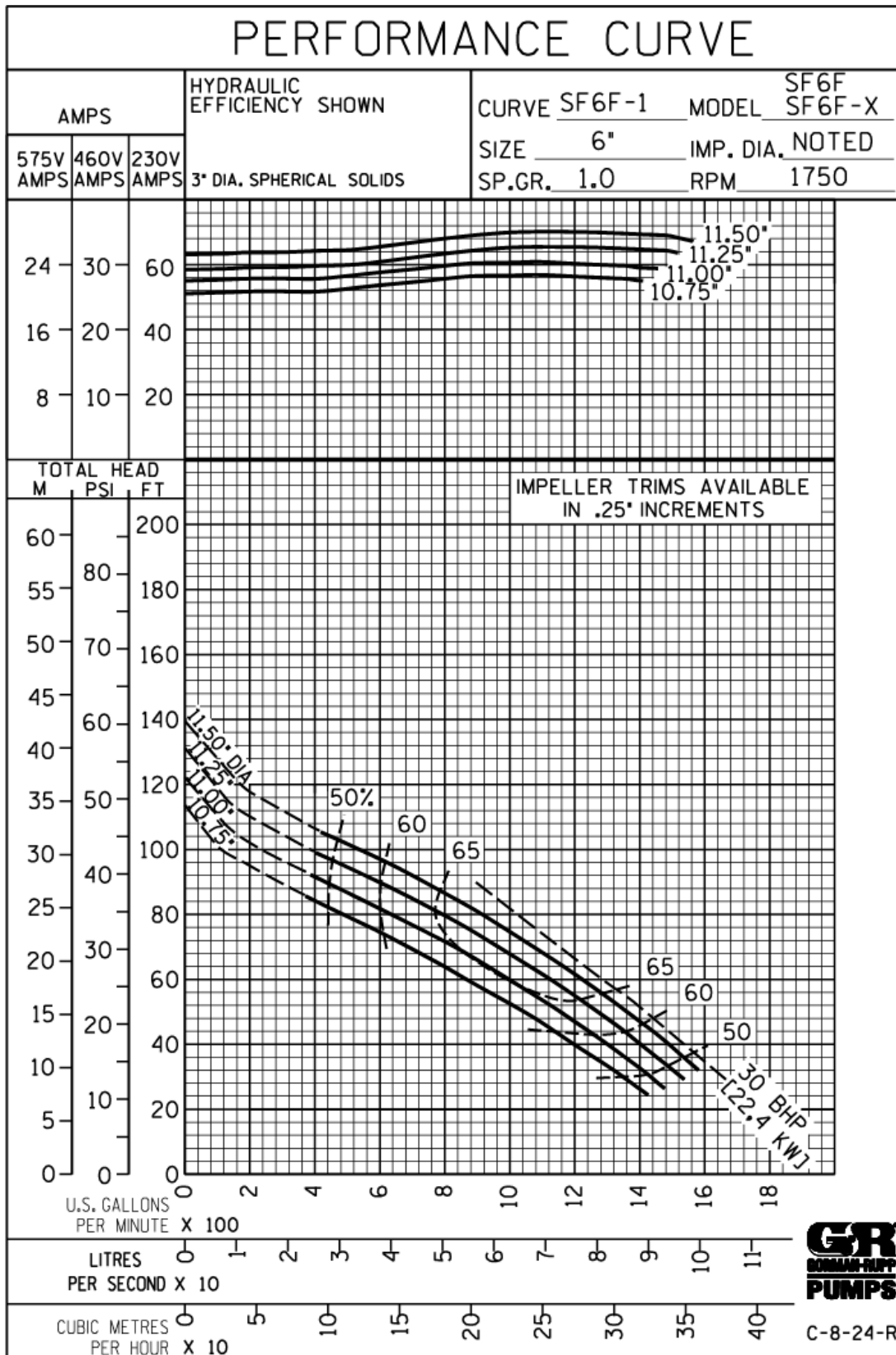

C-8-24-R



### GORMAN-RUPP PUMPS

[www.grpumps.com](http://www.grpumps.com)

Specifications Subject to Change Without Notice

Printed in U.S.A.