

## Electric Motor Driven

## Submersible Pump

Model S8C1 460V 3P and S8C1 575V 3P

Size 8"



## PUMP SPECIFICATIONS

- Diffuser:** Ductile Iron 80-60-03;  
Maximum Operating Pressure 195 psi (1345 kPa).\*
- Impeller:** Ductile Iron 80-55-06.
- Suction Head:** Gray Iron 30.
- Motor Housing:** Aluminum Alloy 356-T6.
- Intermediate Bracket:** Aluminum Alloy 356-T6.
- Seal Plate:** Gray Iron 30.
- Motor Shaft:** Stainless Steel 17-4 PH.
- Bearings:** Upper, Open Single Row Ball.  
Lower, Sealed Double Row Ball.
- Discharge Flange:** Gray Iron 30.
- Gaskets:** Cork <sup>w/</sup>Nitrile Binder (NC710) and Vegetable Fiber.
- O-Ring:** Buna-N
- Wetted Hardware:** Standard Plated Steel and Stainless Steel.
- Strainer:** Urethane Coated Steel; 49% Open Area, 0.62" (15,7 mm)  
Square Openings.
- Hoisting Bail.** Urethane Coated Steel.
- Standard Equipment:** NEMA Type 3R Rainproof Control Box.  
Provides On-Off, Circuit Breaker and Motor Overload Protection.  
(See Section 130, Page 100.)
- Optional Equipment:** Turtle Type Pressure Activated Level Switch. Float  
Activated Level Switch. (See Sec. 130, Page 150.)

## MOTOR/CABLE SPECIFICATIONS

- Motor:** Oil Filled Enclosure; 140 H.P.; 1750 R.P.M.; Inverter Duty Rated  
(VFDCapable) Three Phase: 460/575 Volt, 60 Hz, 176/141 Full Load Amps,  
117 kW (Max.)
- Power Cable:** 6 Wire; Type GGC; 2/0 AWG (460V); 1 AWG (575V);  
3 Power Conductors, 2 Ground Conductors and 1 Ground Check. Nominal  
Length 50 Feet (15 m) Standard. (Specify Alternate Length at Time of Order.)
- Recommended Generator Size:** 200 kW Across-the-Line Start, 150 kW  
for Reduced Voltage Starting.

\* Consult Factory for Applications Exceeding Maximum  
Pressure and/or Temperature Indicated.

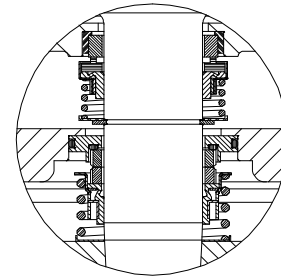
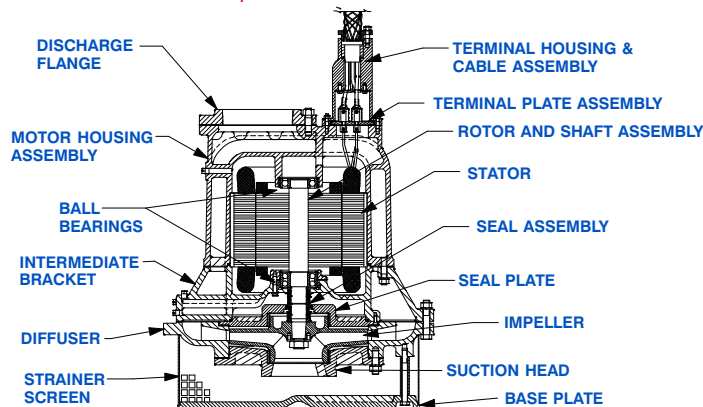

## SEAL SPECIFICATIONS

Tandem, Oil Lubricated.

**Upper Seal:** Type 21, Mechanical. Carbon Rotating Face.  
Ni-Resist Stationary Face. Buna-N Elastomers. Stainless  
Steel 18-8 Cage and Spring.

**Lower Seal:** Type 2, Mechanical. Tungsten Titanium Carbide  
Rotating and Stationary Faces. Stainless Steel 316 Station-  
ary Seat. Fluorocarbon Elastomers (DuPont Viton<sup>®</sup> or  
Equivalent). Stainless Steel 18-8 Cage and Spring.  
Maximum Temperature of Liquid Pumped, 122°F (50°C).\*



GORMAN-RUPP PUMPS

www.grpumps.com

Specifications Subject to Change Without Notice

Printed in U.S.A.

**Specification Data**

APPROXIMATE  
DIMENSIONS and WEIGHTS

**NET WEIGHT: 1610 LBS. (730,3 KG.)**  
**SHIPPING WEIGHT: 1664 LBS. (754,8 KG.)**  
**EXPORT CRATE: 38 CU. FT. (1,08 CU. M.)**

**SECTION 130, PAGE 1560**

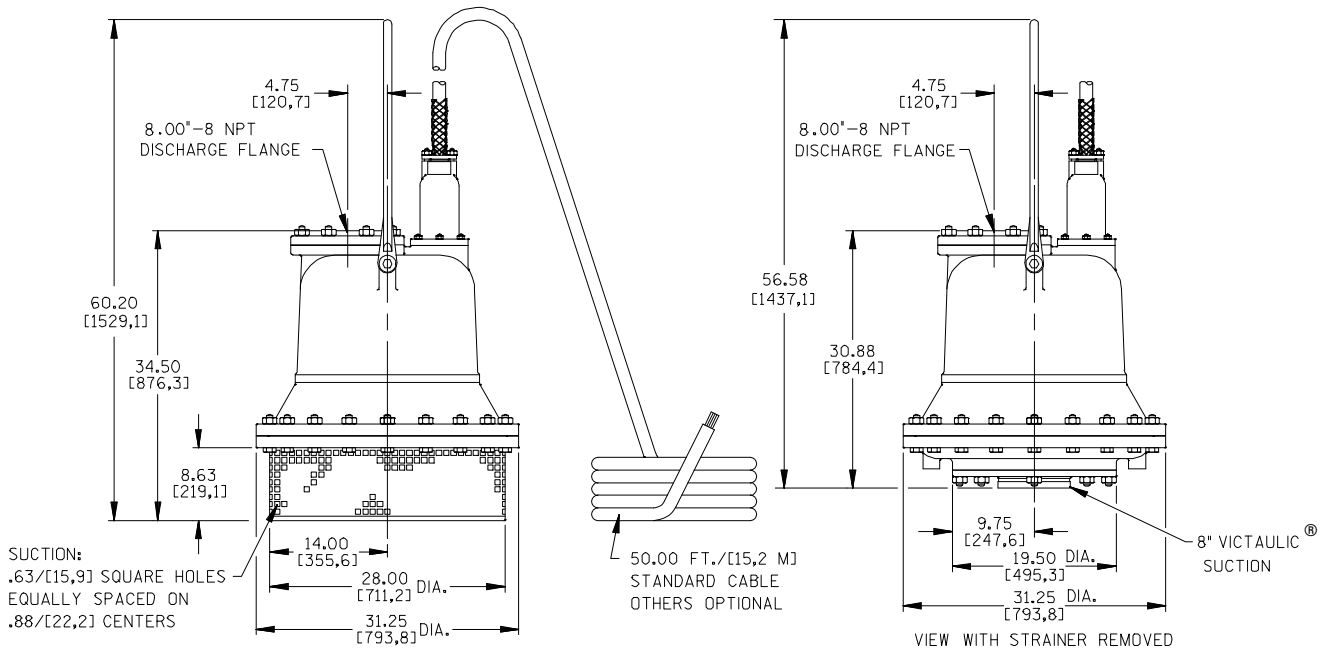

DIMENSIONS:  
INCHES  
[MILLIMETERS]

Victaulic® is a Registered Trademark of Victaulic Company of America.

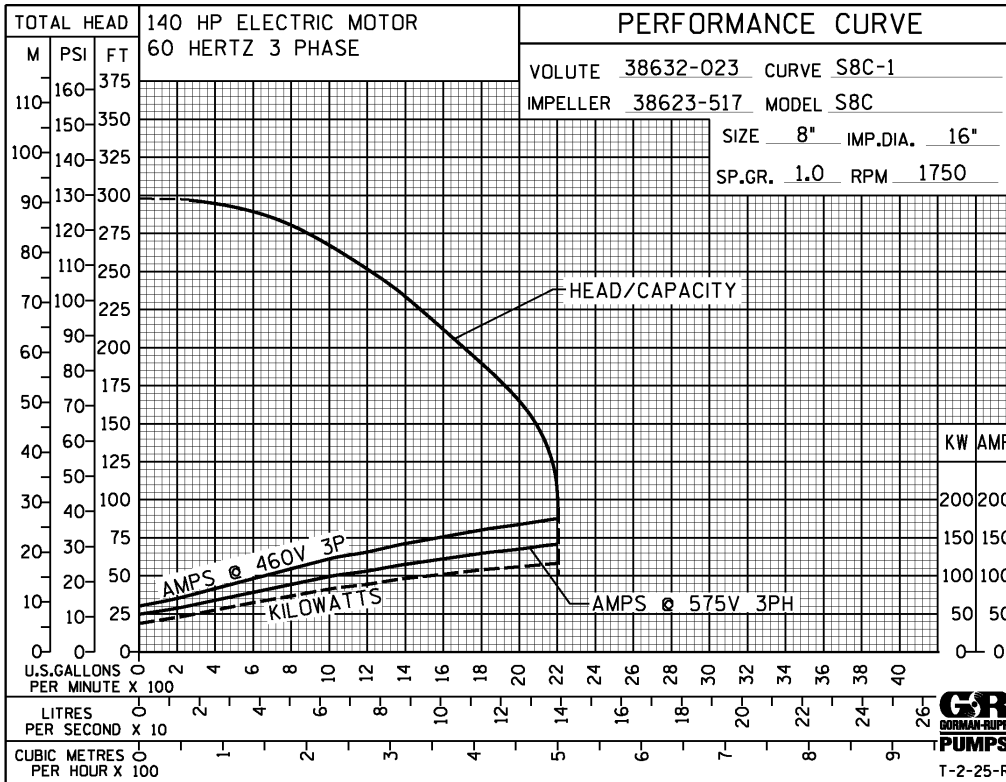

**GORMAN-RUPP PUMPS**

www.grpumps.com

Specifications Subject to Change Without Notice

Printed in U.S.A.