



Submersible Pump

Model S4D1-E10

Size 4"

PUMP SPECIFICATIONS

Diffuser: G-R Hard Iron;

Maximum Operating Pressure 108 psi (747 kPa).*

Impeller: G-R Hard Iron.

Wear Plate: Carbon Steel ASTM A36.

Seal Plate: G-R Hard Iron.

Intermediate: Aluminum Alloy 356-T6.

Casing: Aluminum Alloy 6061-T6 with Chromicoat.

Motor Housing: Aluminum Alloy 356-T6.

Motor Shaft: Stainless Steel Type 416.

Shaft Sleeve: Stainless Steel Type 304.

Bearings: Upper - Open Single Row Ball Bearing.

Lower - Two Synthetic Seals, Double Row Ball Bearing.

Discharge Flange: Aluminum Alloy 356-T6.

Gaskets: Cork with Nitrile Binder (NC710).

O-Rings: Buna-N.

Wetted Hardware: Standard Plated Steel and Stainless Steel.

Strainer: Urethane Coated Steel; 50.6% Open Area,
0.375" (9.5 mm) Diameter Openings.

Hoisting Bail: Urethane Coated Steel.

Standard Equipment

NEMA Type 3R Rainproof Control Box. [\(See Section 130, Page 90.\)](#)

Provides On-Off, Circuit Breaker and Motor Overload Protection.

Optional Equipment

Liquid Level Control: [\(See Sec. 130, Page 150.\)](#)

- Turtle Type Pressure Activated Level Switch.
- Float Activated Level Switch.

Staging Adapter Kit.

MOTOR/CABLE SPECIFICATIONS

Motor: Oil Filled Enclosure; 10.0 H.P.; 3450 R.P.M.; Three Phase:
200/230/460/575 Volt, 60 Hz, 39/34/17/13.6 Full Load AMPS, 12.2 kW (Max.)

Power Cable:

200/230/460 Volt: 6 Wire; Type GGC; 8 AWG. 3 Power Conductors,
2 Ground Conductor and 1 Ground Check.

575 Volt: 4 Wire; Type SO/SOW/SOOW; 10 AWG; 3 Power Conductors,
Plus 1 Ground. Nominal Length 50 Feet (15 m). Standard.
(Specify Alternate Length at Time of Order.)

Recommended Generator Size: 15 kW Across the Line Start.

* Consult Factory for Applications Exceeding Maximum
Pressure and/or Temperature Indicated.

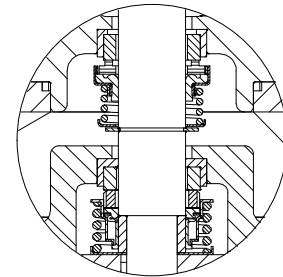
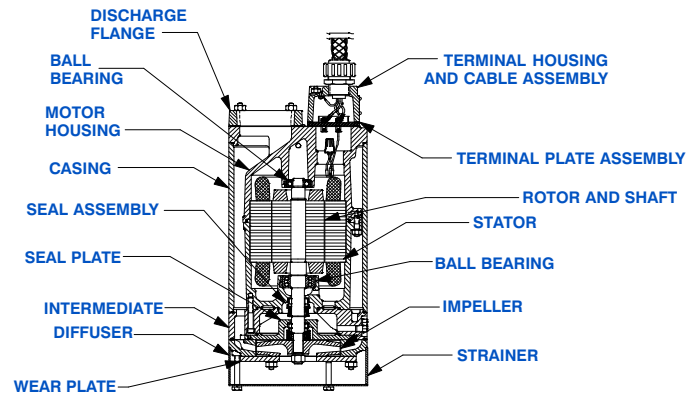

SEAL DETAIL

Tandem, Oil Lubricated.

Upper Seal: Type 21, Mechanical. Carbon Rotating Face. Ceramic Stationary Face. Buna-N Elastomers. Stainless Steel 18-8 Cage and Spring.

Lower Seal: Type 2, Mechanical. Tungsten Titanium Carbide Rotating Face and Silicon Carbide Stationary Face. Fluorocarbon Elastomers (DuPont Viton® or Equivalent). Stainless Steel 303/304 Cage and Spring.
Maximum Temperature of Liquid Pumped, 122°F (50°C).*



GORMAN-RUPP PUMPS

www.grpumps.com

Specifications Subject to Change Without Notice

Printed in U.S.A.

Specification Data

SECTION 130, PAGE 900

APPROXIMATE
DIMENSIONS and WEIGHTS

NET WEIGHT:
SHIPPING WEIGHT:
EXPORT CRATE:

242 LBS. (110 KG.)
257 LBS. (117 KG.)
11.3 CU. FT. (0,32 CU. M.)

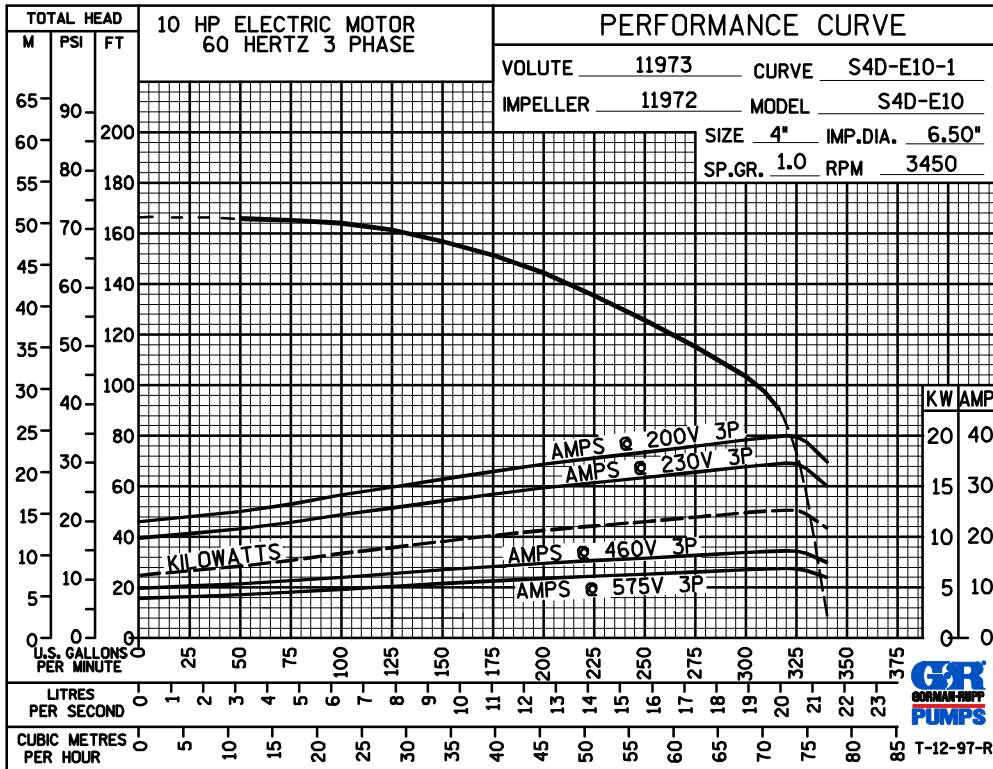
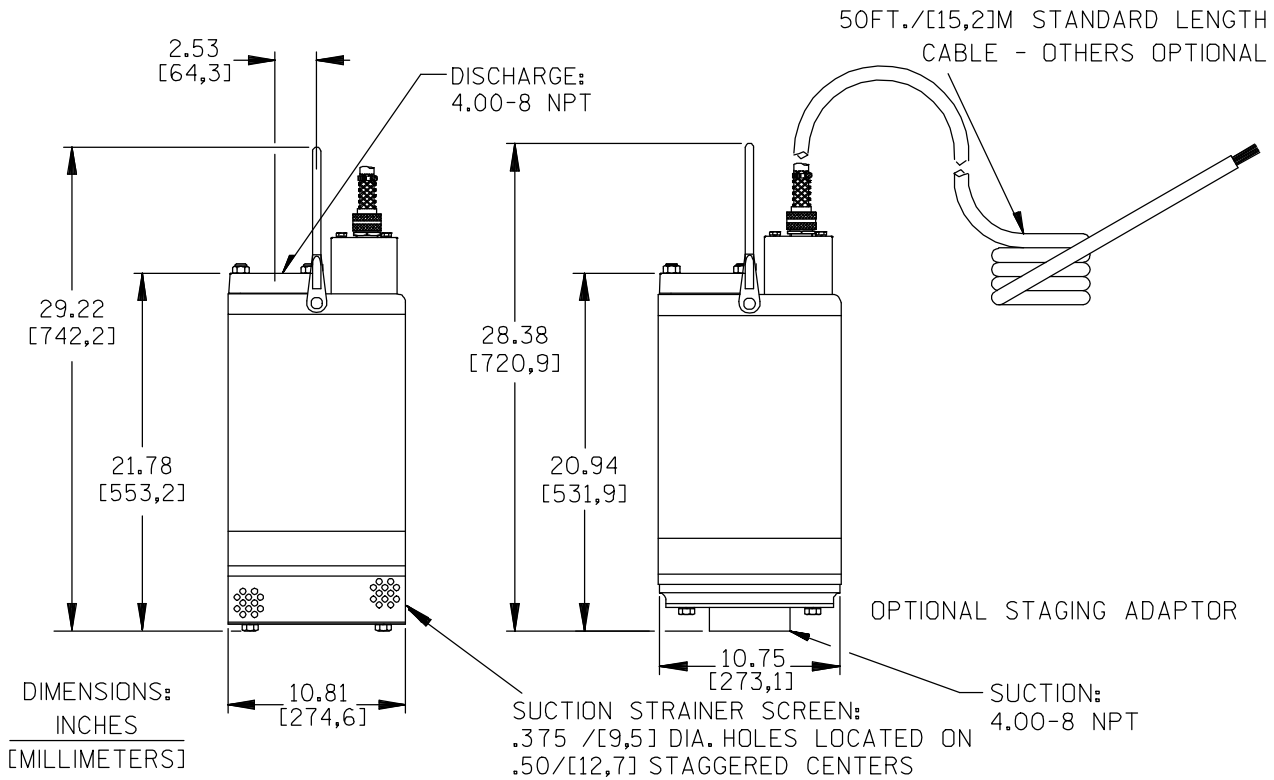

GORMAN-RUPP PUMPS

www.grpumps.com

Specifications Subject to Change Without Notice

Printed in U.S.A.