

Submersible Pump

Models S2B1-E2 115/1, S2B1-E2 230/1 & 230/3, S2B1-E2 460/3, S2B1-E2 575/3

Size 2"



PUMP SPECIFICATIONS

Suction Casing: Gray Iron 30; Maximum Operating Pressure 39 psi (269 kPa).*

Impeller: Copper Alloy C86500.

Seal Plate: Gray Iron 30.

Intermediate: Aluminum Alloy 356-T6.

Motor Housing: Aluminum Alloy 356-T6.

Motor Shaft: Stainless Steel 17-4 PH.

Bearings: Upper and Lower, Open Single Row Ball Bearing.

Discharge Flange: Aluminum Alloy 356-T6.

Gaskets: Cork with Nitrile Binder (NC710).

O-Rings: Buna-N.

Wetted Hardware: Standard Plated Steel and Stainless Steel.

Strainer: Urethane Coated Steel; 47% Open Area, 0.31" (7.9 mm) Diameter Openings.

Hoisting Bail: Urethane Coated Steel.

Standard Equipment

NEMA Type 3R Rainproof Control Box.

Provides On-Off, Circuit Breaker and Motor Overload Protection.

Optional Equipment

Liquid Level Control: (See Sec. 130, Page 150.)

a. Turtle Type Pressure Activated Level Switch.

b. Float Activated Level Switch.

Staging Adapter Kit.

MOTOR/CABLE SPECIFICATIONS

Motor: Oil Filled Enclosure. 2.0 H.P.; 3450 R.P.M.; 60 Hz.

Single Phase: 115/230 Volt, 28/12 Full Load AMPS, 2.6/2.4 kW (Max.)

Three Phase: 230/460/575 Volt, 7.2/3.6/2.9 Full Load AMPS, 2.2 kW (Max.)

Power Cable: (115V) 6 Wire; Type GGC; 8 AWG; 3 Power Conductors, 2 Ground and 1 Ground Check.

(230V, 460V and 575V) 4 Wire; Type SO/SOW/SOOW/SEOW/SEOOW; 14 AWG; 3 Power Conductors, Plus 1 Ground.

Nominal Length 50 Feet (15 m) Standard.
(Specify Alternate Length at Time of Order.)

Recommended Generator Size: 6 kW Across the Line Start.

* Consult Factory for Applications Exceeding Maximum Pressure and/or Temperature Indicated.

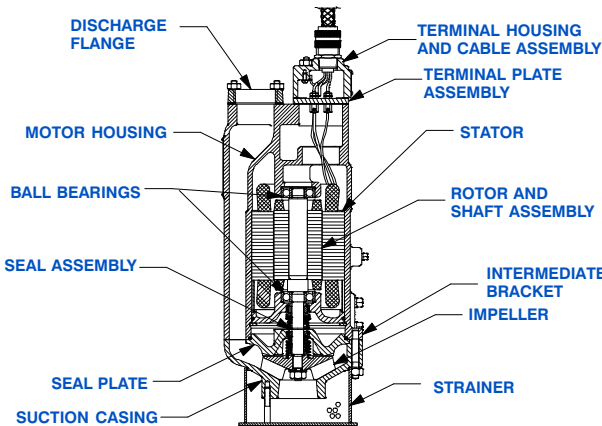
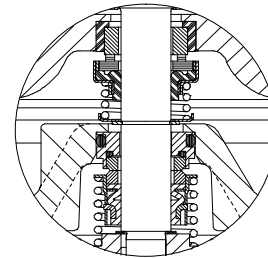

SEAL SPECIFICATIONS

Tandem, Oil Lubricated.

Upper: Type 21 Mechanical. Carbon Rotating Face. Ceramic Stationary Face. Buna-N Elastomers. Stainless Steel 18-8 Cage and Spring.

Lower: Type 2 Mechanical. Tungsten Carbide Rotating and Stationary Faces. Buna-N Elastomers. Stainless Steel 316 Cage, Spring and Stationary Seat.

Maximum Temperature of Liquid Pumped 122°F (50°C).*



GORMAN-RUPP PUMPS

www.grpumps.com

Specifications Subject to Change Without Notice

Printed in U.S.A.

Specification Data

SECTION 130, PAGE 382

APPROXIMATE DIMENSIONS and WEIGHTS

NET WEIGHT: 98 LBS. (44,5 KG.)
 SHIPPING WEIGHT: 108 LBS. (49,0 KG.)
 EXPORT CRATE: 5.0 CU. FT. (0,14 CU. M.)

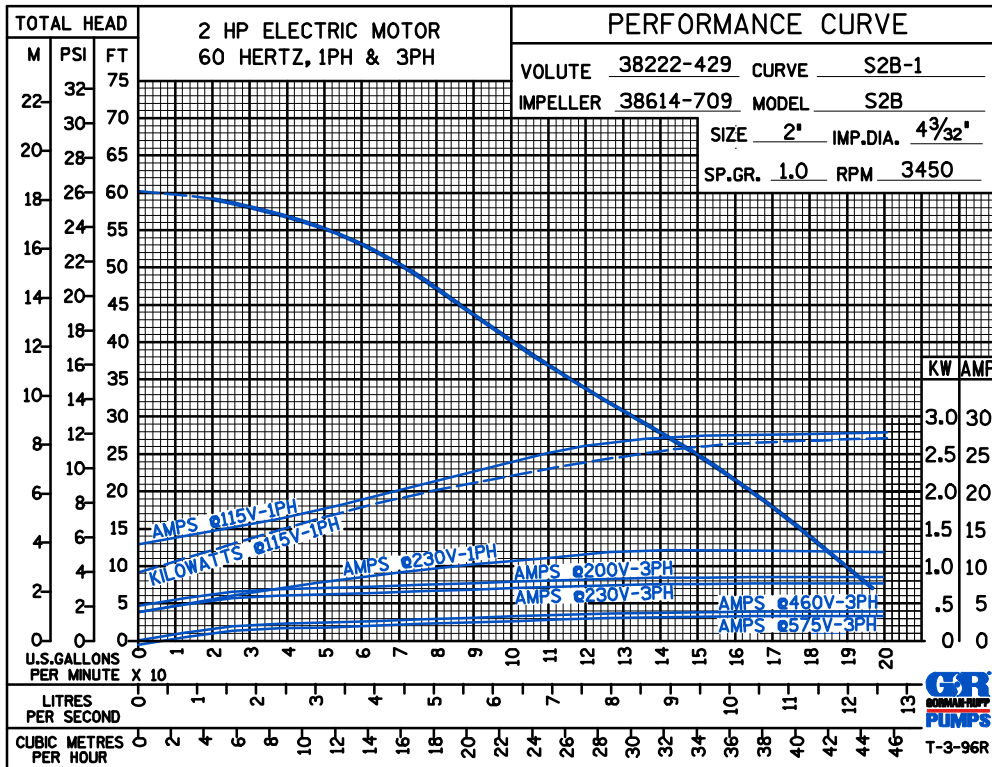
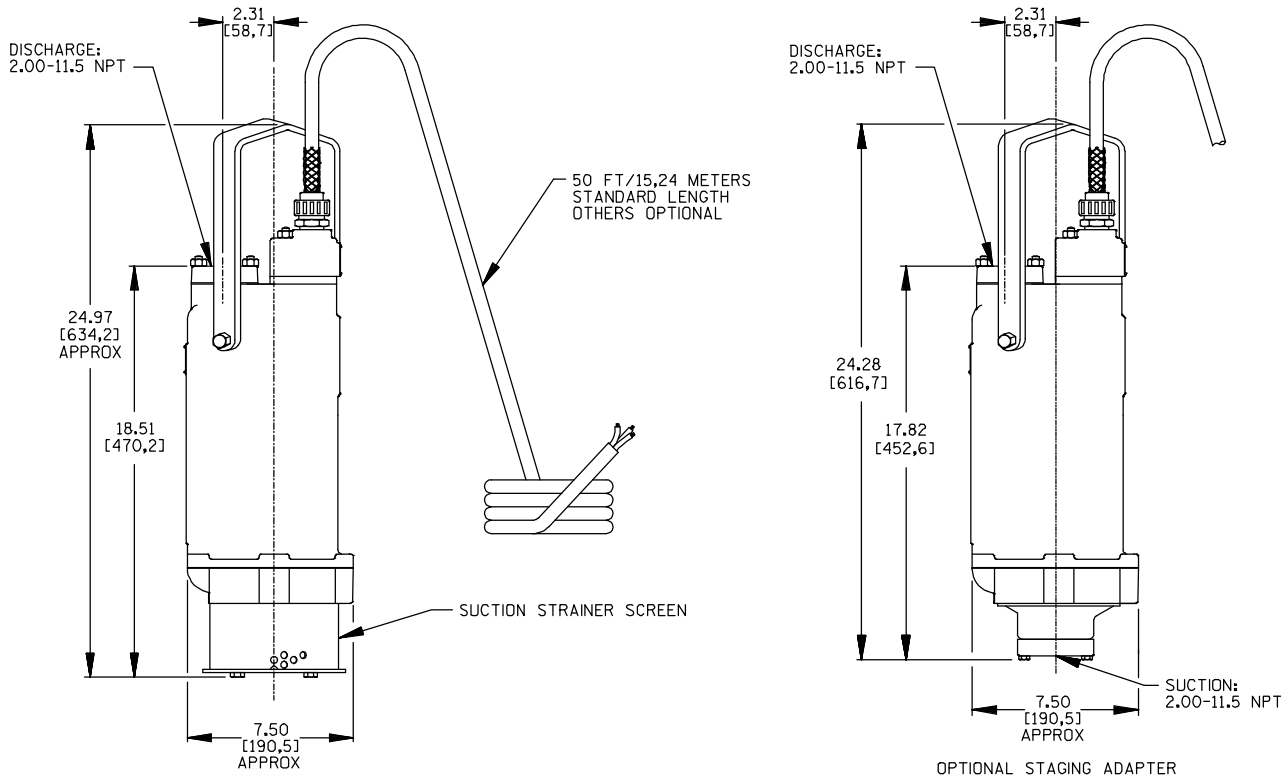

GORMAN-RUPP PUMPS

www.grpumps.com

Specifications Subject to Change Without Notice

Printed in U.S.A.