

Standard Centrifugal Pump

Model 6510C31-B

Size 10" x 10"



PUMP SPECIFICATIONS

Size: 10" x 10" (254 mm x 254 mm) Flanged.

Casing: Ductile Iron 65-45-12.

Maximum Operating Pressure 103 psi (710 kPa).*

Open Type, Two Vane Impeller: Ductile Iron 65-45-12.
Handles 3.25" (88,6 mm) Diameter Spherical Solids.

Suction Head: Ductile Iron 65-45-12.

Suction Spool: Ductile Iron 65-45-12.

Impeller Shaft: Alloy Steel 4150.

Replaceable Wear Ring: Ductile Iron 80-55-06.

Pedestal: Gray Iron 30.

Seal Plate: Ductile Iron 65-45-12.

Radial Bearing: Open Single Row Roller.

Thrust Bearing: Open Double Row Ball.

Bearing and Seal Cavity Lubrication: SAE 30 Non-Detergent Oil.

Gaskets: Vegetable Fiber, Red Rubber and Buna-N.

O-Rings: Buna-N.

Hardware: Standard Plated Steel.

Bearing and Seal Cavity Oil Level Sight Gauges.

**Consult Factory for Applications Exceeding Maximum Pressure and/or Temperature Indicated.*

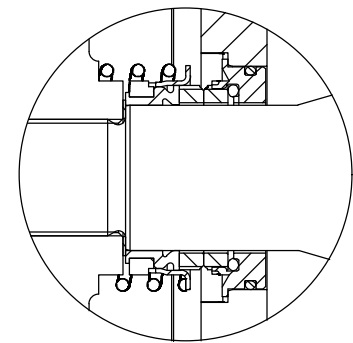
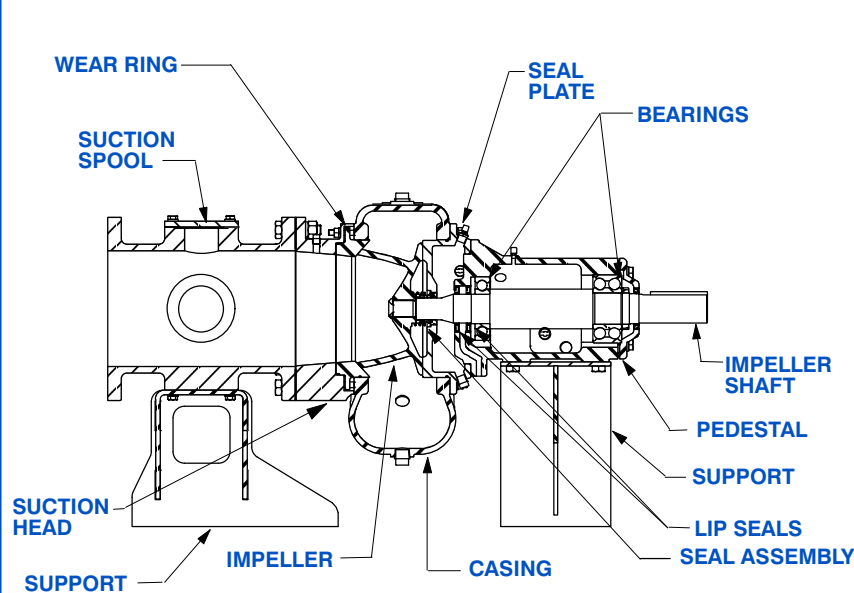

SEAL DETAIL

Mechanical, Oil-Lubricated. Silicon Carbide Rotating Face and Stationary Seat. Fluorocarbon Elastomers (DuPont Viton® or Equivalent). Stainless Steel 316 Cage and Stainless Steel 18-8 Spring. Maximum Temperature of Liquid Pumped 160°F (71°C).*



GORMAN-RUPP PUMPS

www.grpumps.com

Specifications Subject to Change Without Notice

Printed in U.S.A.

Specification Data

SECTION 65, PAGE 551

APPROXIMATE DIMENSIONS and WEIGHTS

NET WEIGHT: 893 LBS. (405,1 KG.)
SHIPPING WEIGHT: 1050 LBS. (476,3 KG.)
EXPORT CRATE: 53 CU. FT. (1,5 CU. M.)

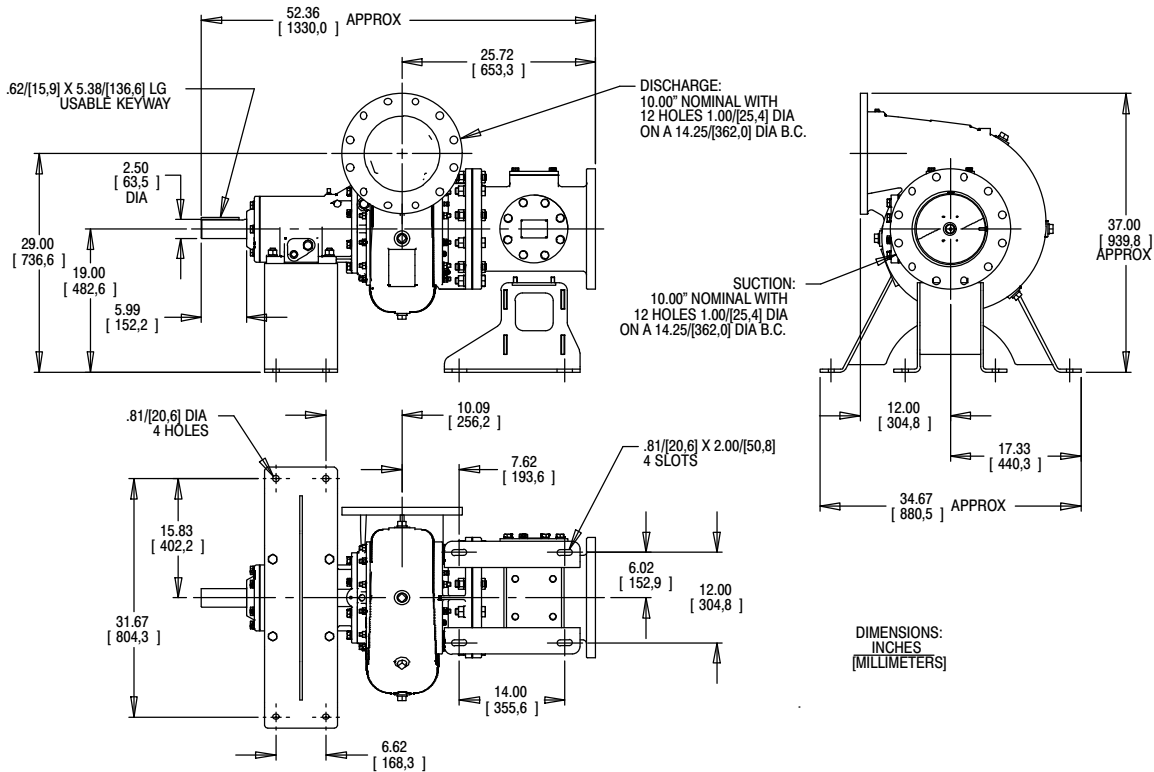

MULTI-SPEED CURVE PERFORMANCE BASED ON WATER

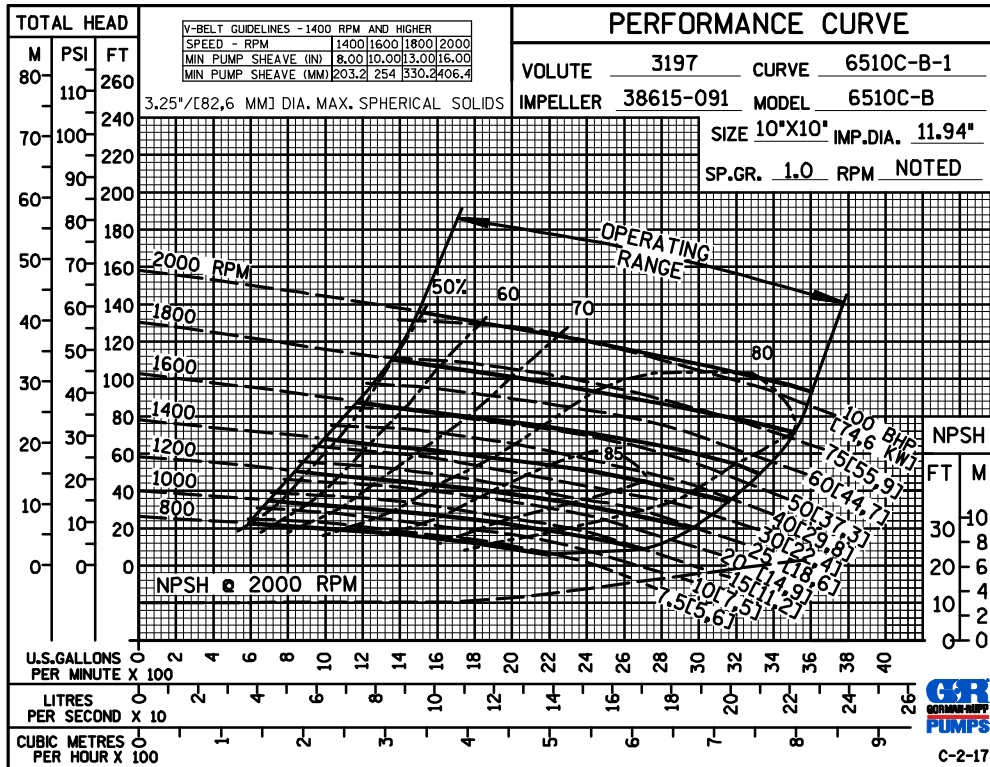

GORMAN-RUPP PUMPS

www.grpumps.com

Specifications Subject to Change Without Notice

Printed in U.S.A.

**60 HERTZ
PERFORMANCE
BASED ON
WATER
TRIMMED
IMPELLER**

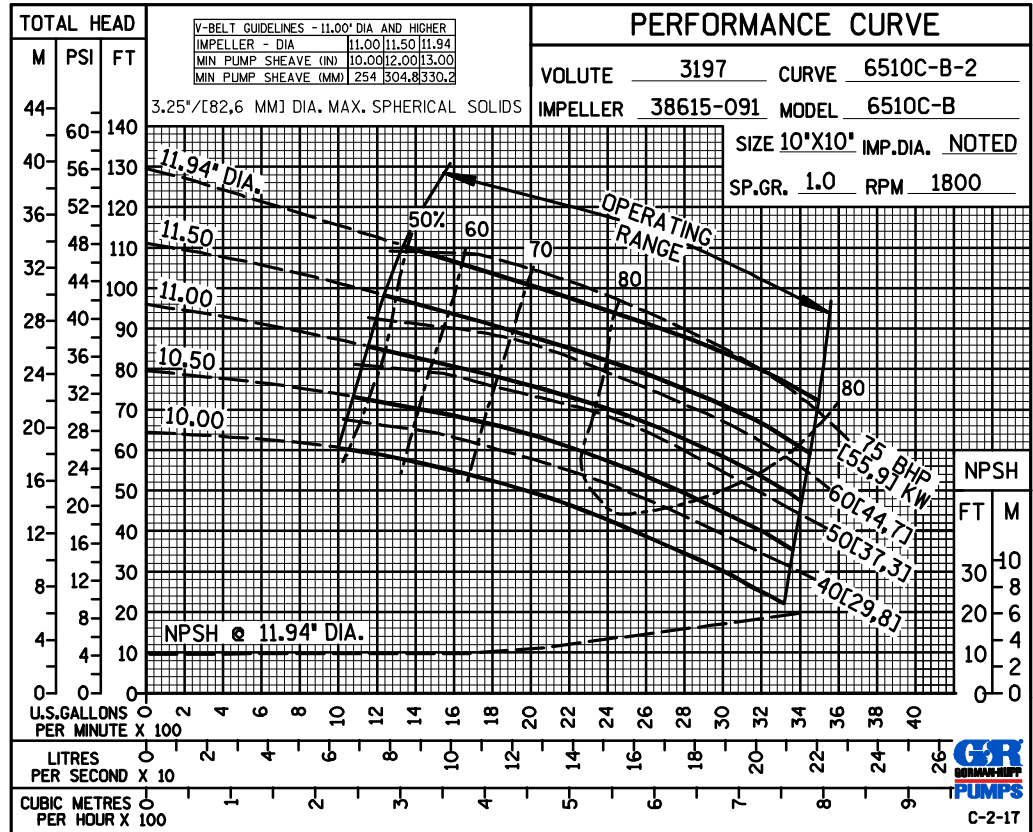

**60 HERTZ
PERFORMANCE
BASED ON
WATER
TRIMMED
IMPELLER**

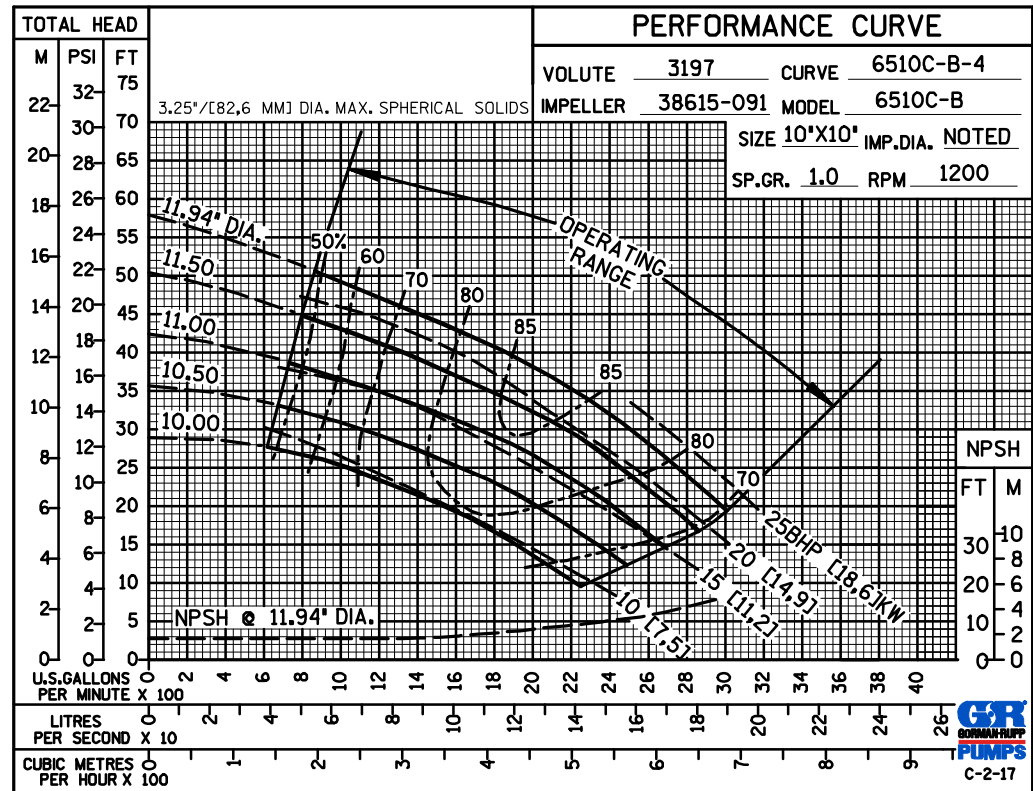

GORMAN-RUPP PUMPS

www.grpumps.com

Specifications Subject to Change Without Notice

Printed in U.S.A.

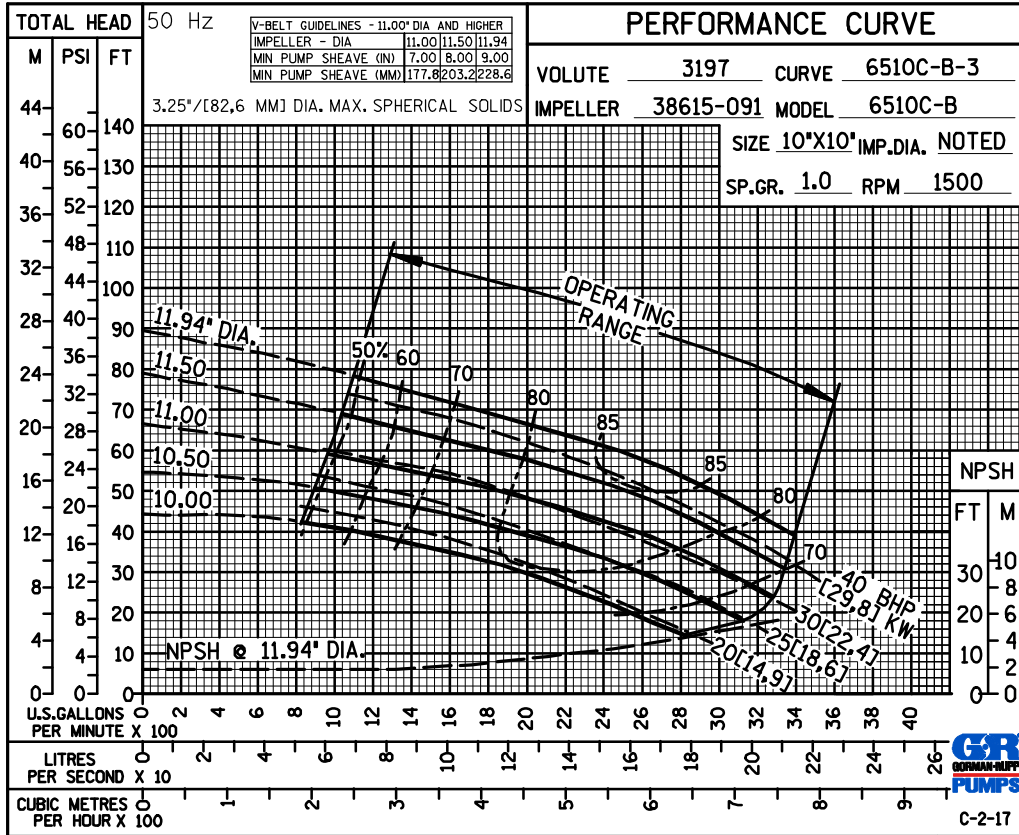

GORMAN-RUPP PUMPS

www.grpumps.com

Specifications Subject to Change Without Notice

Printed in U.S.A.