

Standard Centrifugal Pump

Model 6508A31-B

Size 10" x 8"



PUMP SPECIFICATIONS

Size: 10" x 8" (254 mm x 203 mm) Flanged.

Casing: Ductile Iron 65-45-12.

Maximum Casing Pressure 264 psi (1820 kPa).*

Maximum Operating Pressure 250 psi (1723 kPa) at Temperatures up to 100°F (37°C) Based on System Component Limitations.*

Enclosed Type, Two Vane Impeller: Ductile Iron 65-45-12.

Handles 3" (76,2 mm) Diameter Spherical Solids.

Suction Head: Ductile Iron 65-45-12.

Suction Spool: Ductile Iron 65-45-12.

Impeller Shaft: Alloy Steel 4150.

Replaceable Wear Ring: Ductile Iron 65-45-12.

Pedestal: Gray Iron 30.

Seal Plate: Ductile Iron 65-45-12.

Shaft Sleeve: Stainless Steel 303/304.

Radial Bearing: Open Single Row Roller.

Thrust Bearing: Open Double Row Ball.

Bearing and Seal Cavity Lubrication: SAE 30 Non-Detergent Oil.

Gaskets: Red Rubber and Buna-N.

O-Rings: Buna-N.

Hardware: Standard Plated Steel.

Bearing and Seal Cavity Oil Level Sight Gauges.

**Consult Factory for Applications Exceeding Maximum Pressure and/or Temperature Indicated.*

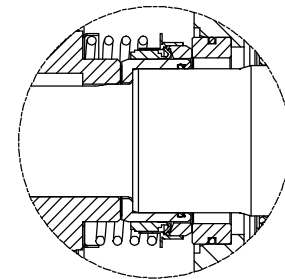
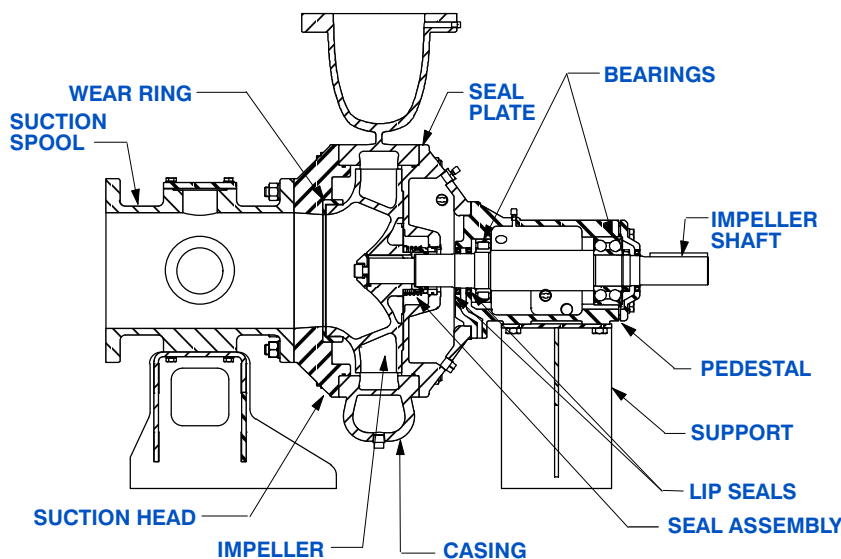

SEAL DETAIL

Mechanical, Oil-Lubricated. Silicon Carbide Rotating Face and Stationary Seat. Fluorocarbon Elastomers (DuPont Viton® or Equivalent). Stainless Steel 316 Cage and Stainless Steel 18-8 Spring. Maximum Temperature of Liquid Pumped 160°F (71°C).*



GORMAN-RUPP PUMPS

www.grpumps.com

Specifications Subject to Change Without Notice

Printed in U.S.A.

Specification Data

SECTION 65, PAGE 402

APPROXIMATE
DIMENSIONS and WEIGHTS

NET WEIGHT: 1153 LBS. (523,0 KG.)
SHIPPING WEIGHT: 1303 LBS. (591,0KG.)
EXPORT CRATE: 65.6 CU. FT. (3,6 CU. M.)

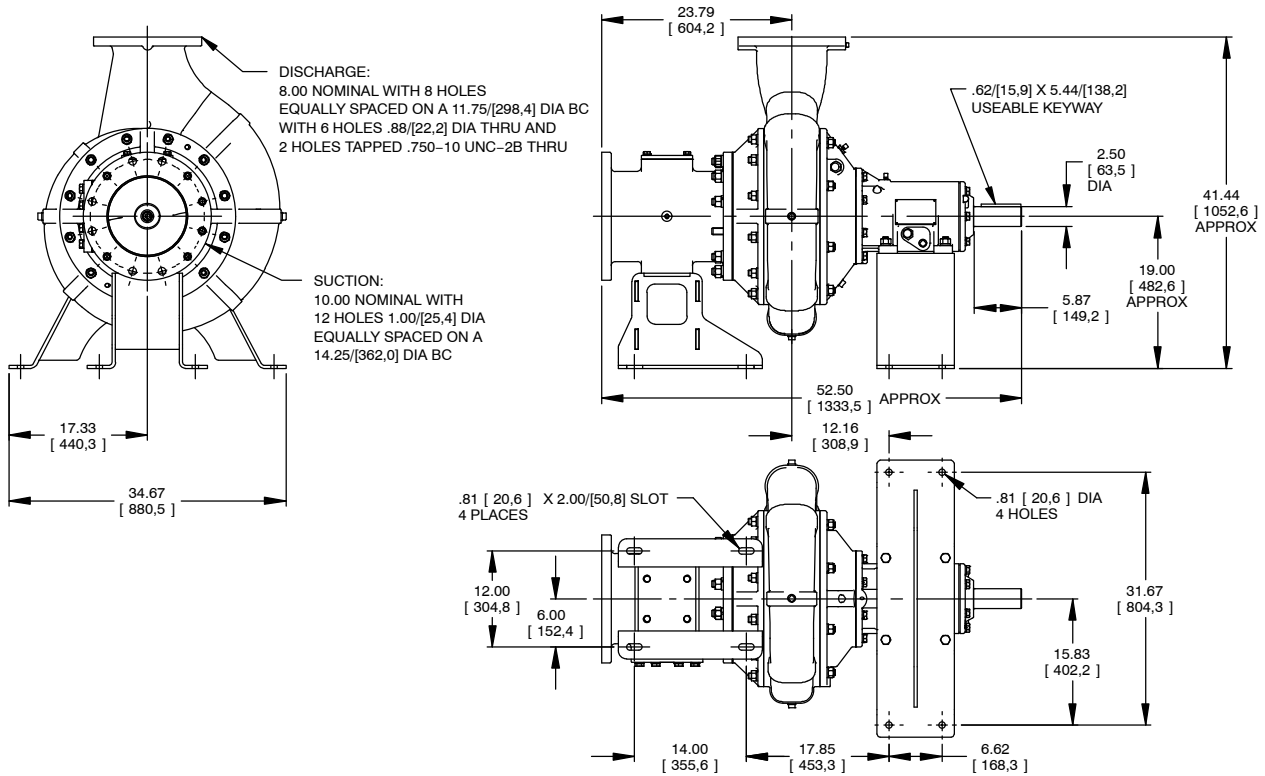

**MULTI-SPEED
CURVE
PERFORMANCE
BASED ON
WATER**

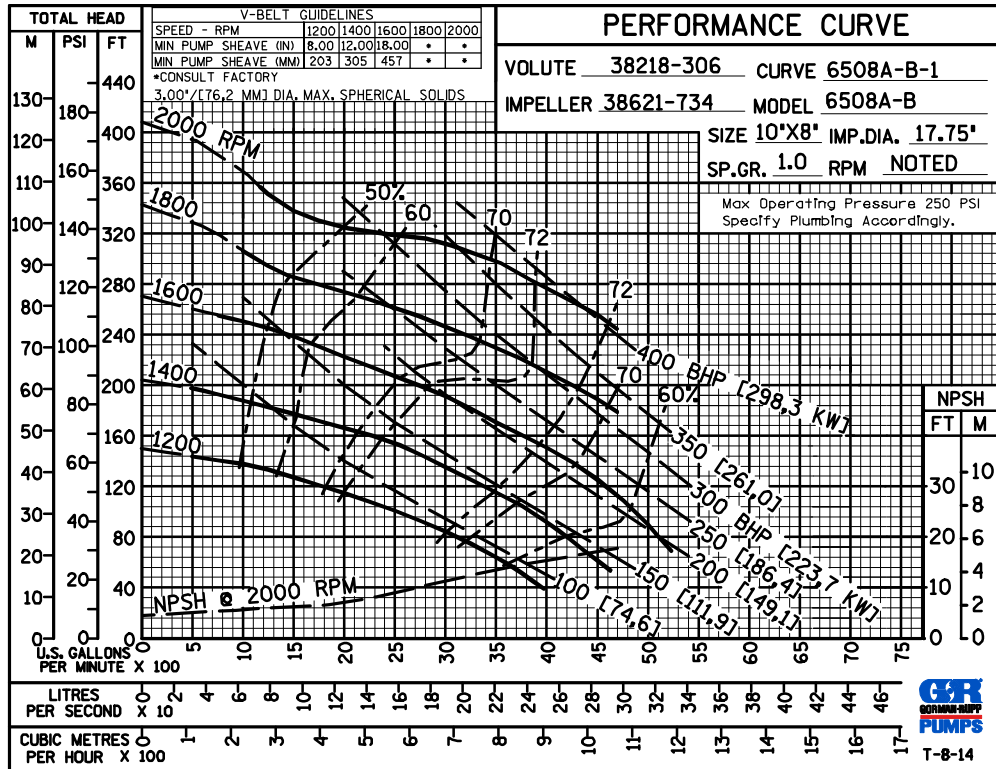

GORMAN-RUPP PUMPS

www.grpumps.com

Specifications Subject to Change Without Notice

Printed in U.S.A.

60 HERTZ
PERFORMANCE
BASED ON
WATER
TRIMMED
IMPELLER

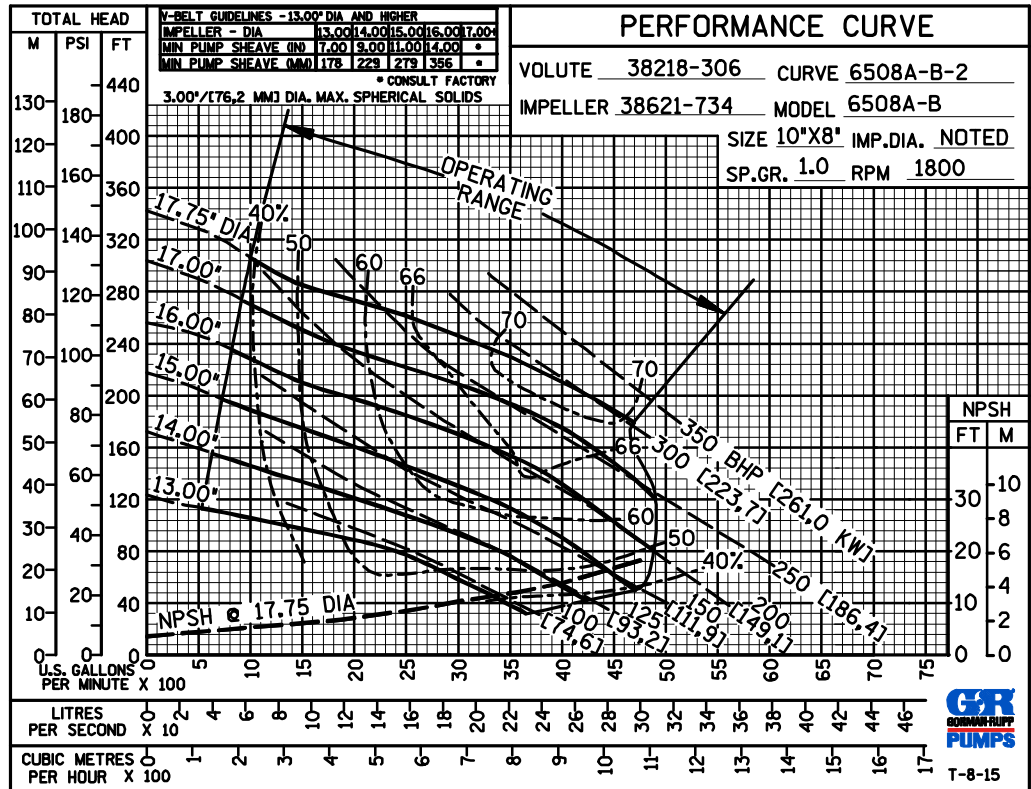

60 HERTZ
PERFORMANCE
BASED ON
WATER
TRIMMED
IMPELLER

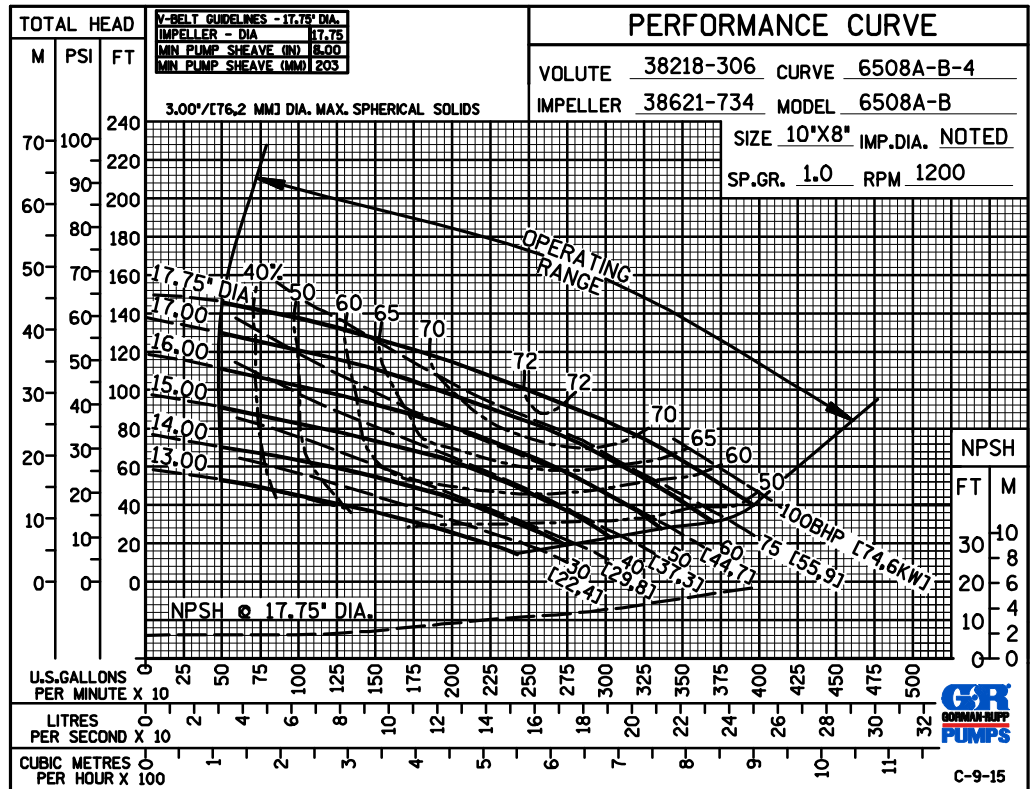

GORMAN-RUPP PUMPS

www.grpumps.com

Specifications Subject to Change Without Notice

Printed in U.S.A.

**50 HERTZ
PERFORMANCE
BASED ON
WATER
TRIMMED
IMPELLER**

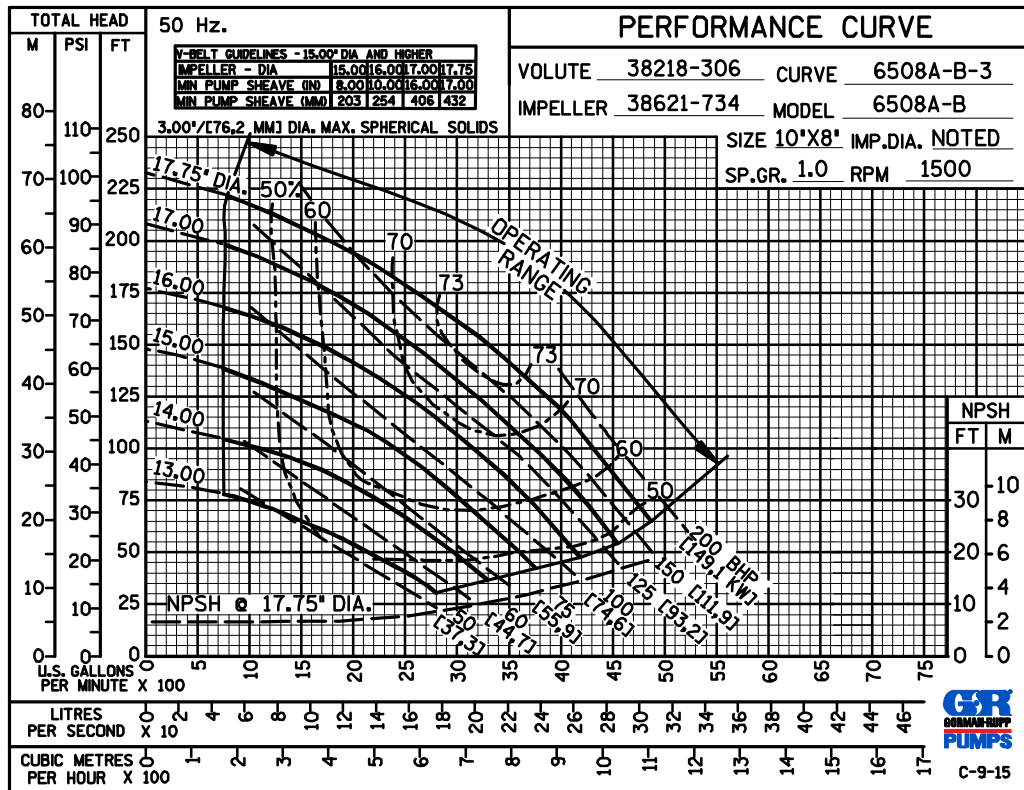

GORMAN-RUPP PUMPS

www.grpumps.com

Specifications Subject to Change Without Notice

Printed in U.S.A.