

Standard Centrifugal Pump



Model 6506E60-B

Size 8" x 6"

PUMP SPECIFICATIONS

Size: 8" x 6" (203 mm x 152 mm) Flanged.

Casing: Ductile Iron 65-45-12.

Maximum Casing Pressure 276 psi (1903 kPa).*

Maximum Operating Pressure 250 psi (1724 kPa) at Temperatures up to 100° F (37° C) Based on System Component Limitations.*

Enclosed Type, Five Vane Impeller: Ductile Iron 80-55-06.

Handles 1 1/4" (31,8 mm) Diameter Spherical Solids.

Suction Head: Gray Iron 30.

Impeller Shaft: Alloy Steel 4150.

Replaceable Wear Ring: Ductile Iron 65-45-12.

Pedestal: Gray Iron 30.

Seal Plate: Ductile Iron 65-45-12.

Shaft Sleeve: Stainless Steel 303/304.

Radial Bearing: Open Roller.

Thrust Bearing: Open Double Ball.

Bearing and Seal Cavity Lubrication: SAE 30 Non-Detergent Oil.

Gaskets: Fluorocarbon (DuPont Viton® or Equivalent), Red Rubber and Buna-N.

O-Rings: Buna-N.

Hardware: Standard Plated Steel.

Bearing and Seal Cavity Oil Level Sight Gauges.

**Consult Factory for Applications Exceeding Maximum Pressure and/or Temperature Indicated.*

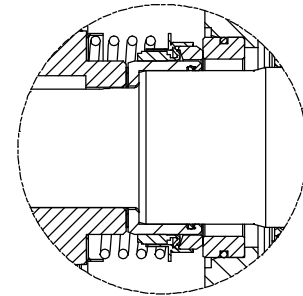
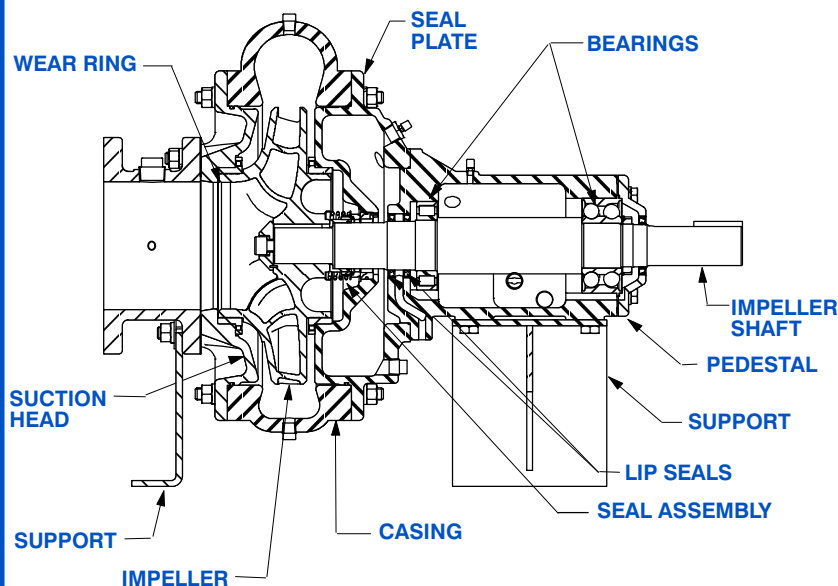
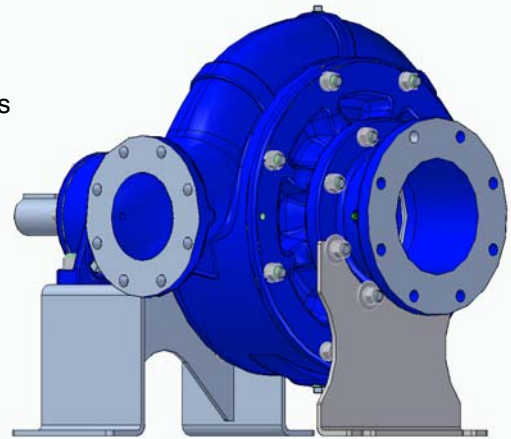

SEAL DETAIL

Mechanical, Oil-Lubricated. Silicon Carbide Rotating Face and Stationary Seat. Fluorocarbon Elastomers (DuPont Viton® or Equivalent). Stainless Steel 316 Cage and Stainless Steel 18-8 Spring. Maximum Temperature of Liquid Pumped 160° F (71° C).*



GORMAN-RUPP PUMPS

www.grpumps.com

Specifications Subject to Change Without Notice

Printed in U.S.A.

Specification Data

SECTION 65, PAGE 320

APPROXIMATE
DIMENSIONS and WEIGHTS

NET WEIGHT: 1020 LBS. (462,7 KG.)
SHIPPING WEIGHT: 1150 LBS. (521,6 KG.)
EXPORT CRATE: 29.6 CU. FT. (0,8 CU. M.)

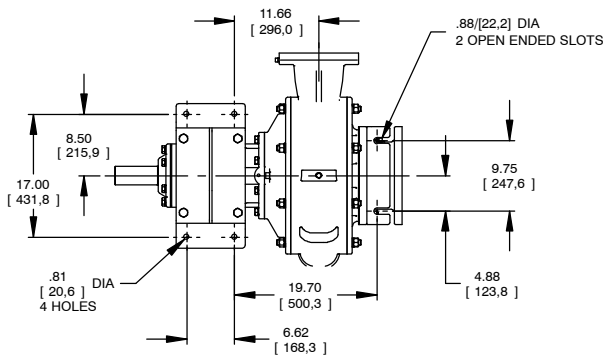
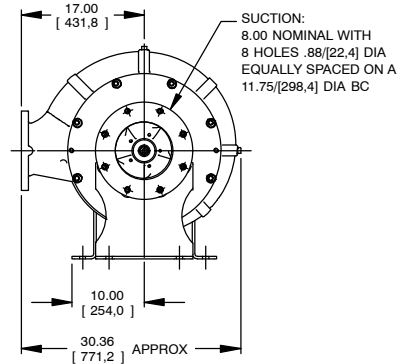
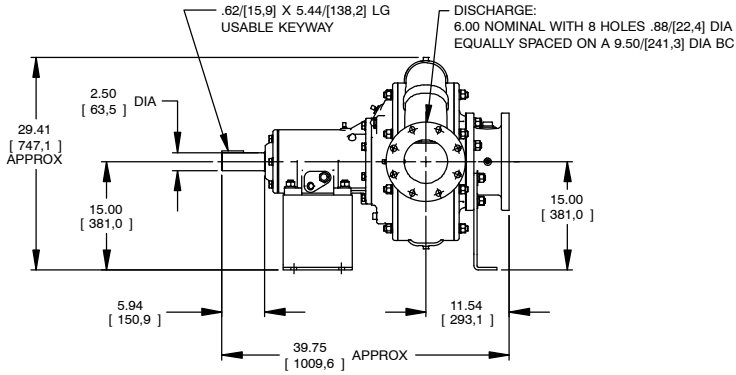

DIMENSIONS:
INCHES
[MILLIMETERS]

**MULTI-SPEED
CURVE
PERFORMANCE
BASED ON
WATER**

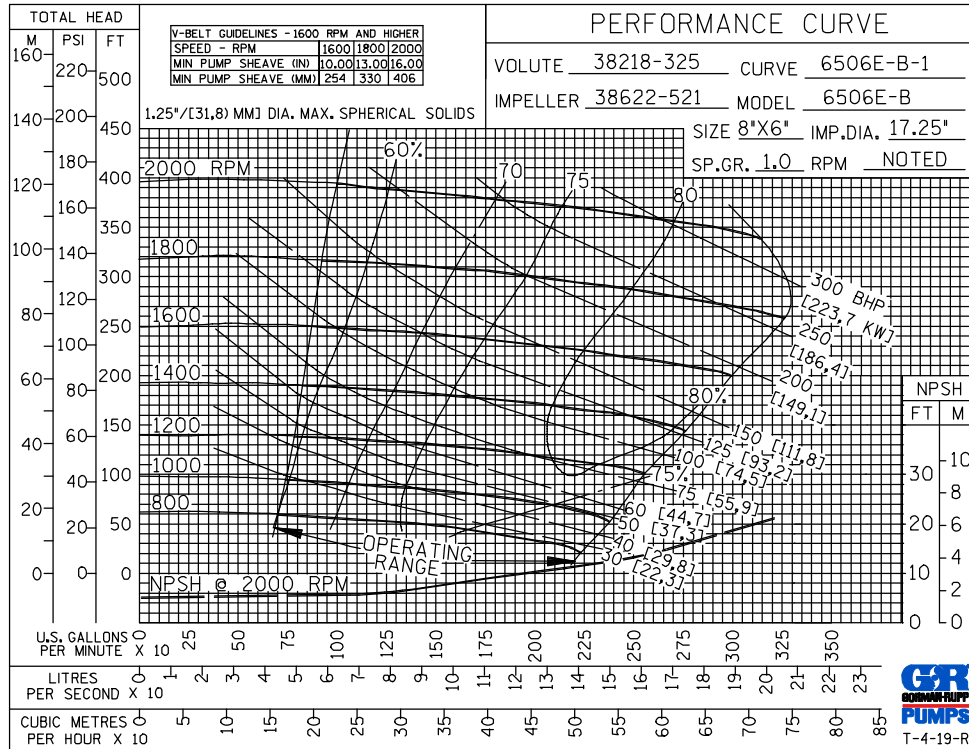

GORMAN-RUPP PUMPS

www.grpumps.com

Specifications Subject to Change Without Notice

Printed in U.S.A.

**60 HERTZ
PERFORMANCE
BASED ON
WATER
TRIMMED
IMPELLER**

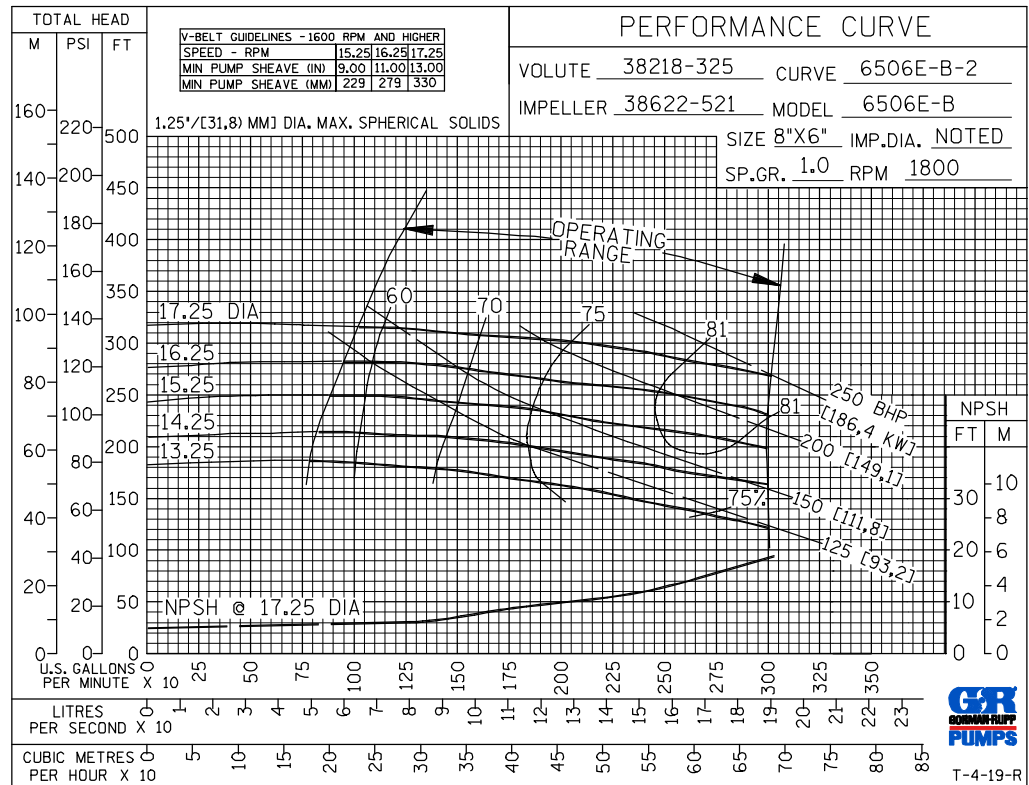

**50 HERTZ
PERFORMANCE
BASED ON
WATER
TRIMMED
IMPELLER**

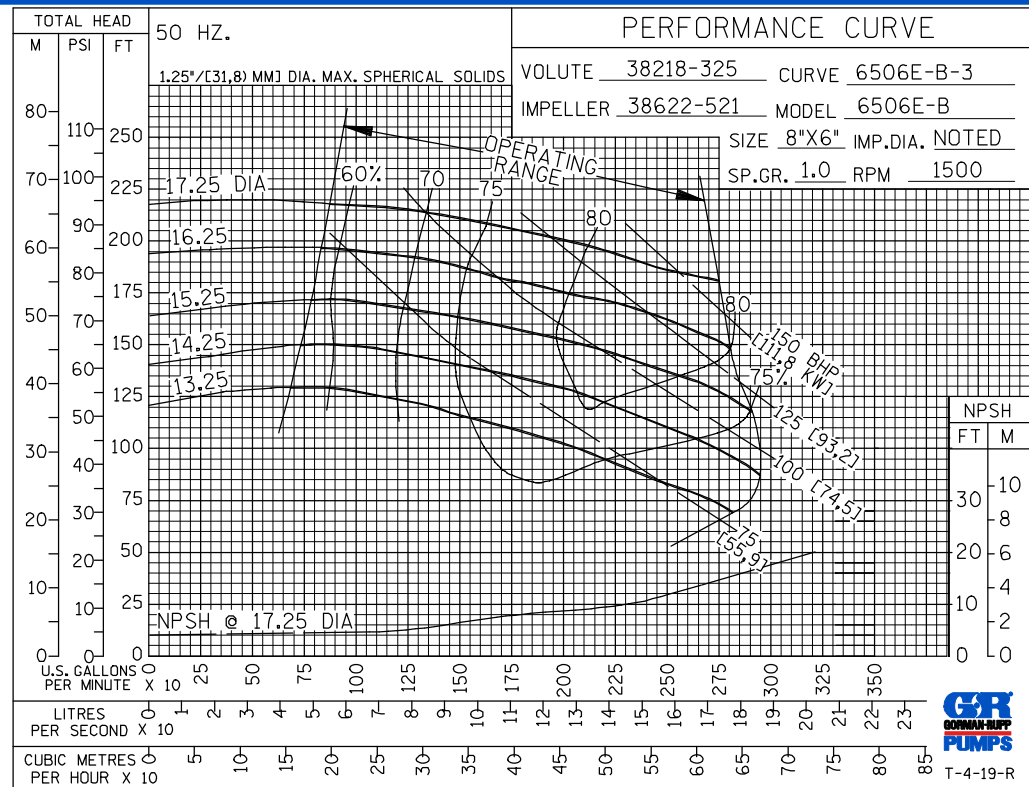

GORMAN-RUPP PUMPS

www.grpumps.com

Specifications Subject to Change Without Notice

Printed in U.S.A.

**60 HERTZ
PERFORMANCE
BASED ON
WATER
TRIMMED
IMPELLER**

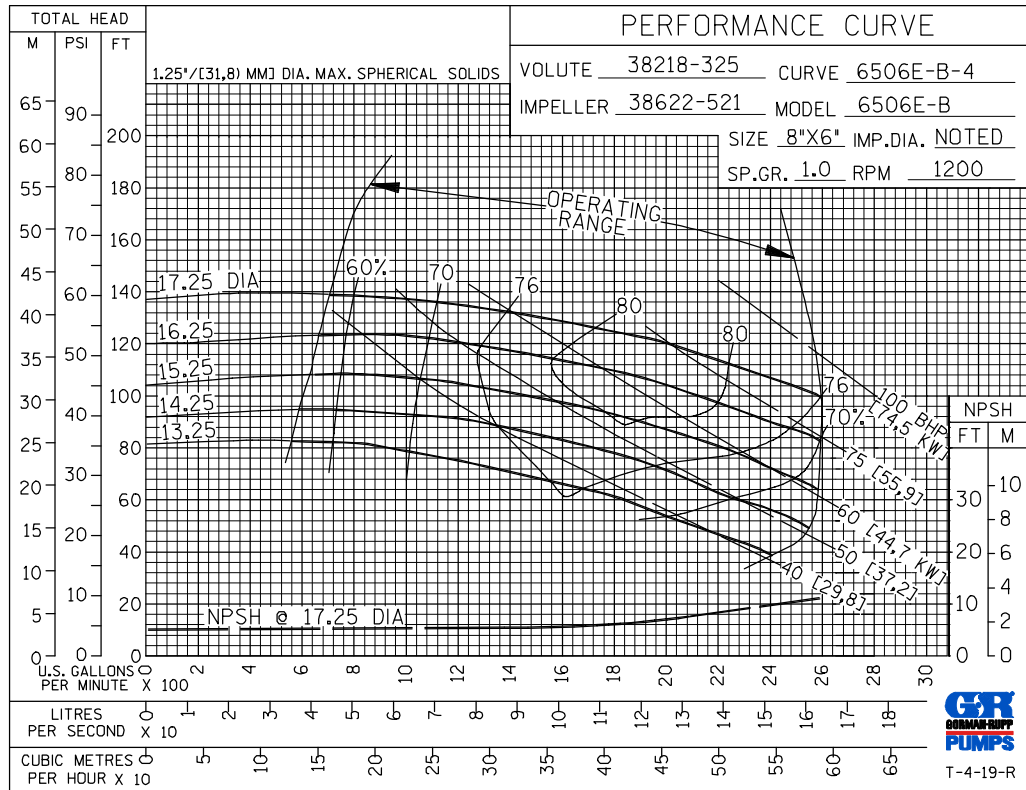

GORMAN-RUPP PUMPS

www.grpumps.com

Specifications Subject to Change Without Notice

Printed in U.S.A.