

## Ductile Iron Basic Pedestal

## Standard Centrifugal Pump

Model 6506C31-B

Size 8" x 6"



## PUMP SPECIFICATIONS

**Size:** 8" x 6" (203 mm x 152 mm) Flanged.

**Casing:** Ductile Iron 65-45-12.

Maximum Casing Pressure 225 psi (1551 kPa).\*

**Enclosed Type, Two Vane Impeller:** Ductile Iron 65-45-12.

Handles 3" (76,2 mm) Diameter Spherical Solids.

**Suction Head:** Ductile Iron 65-45-12.

**Suction Spool:** Ductile Iron 65-45-12.

**Impeller Shaft:** Alloy Steel 4150.

**Replaceable Wear Ring:** Ductile Iron 65-45-12.

**Pedestal:** Gray Iron 30.

**Seal Plate:** Ductile Iron 65-45-12.

**Shaft Sleeve:** Stainless Steel 303/304.

**Radial Bearing:** Open Single Row Roller.

**Thrust Bearing:** Open Double Row Ball.

**Bearing and Seal Cavity Lubrication:** SAE 30 Non-Detergent Oil.

**Gaskets:** Vegetable Fiber, Red Rubber and Buna-N.

**O-Rings:** Buna-N.

**Hardware:** Standard Plated Steel.

**Bearing and Seal Cavity Oil Level Sight Gauges.**

*\*Consult Factory for Applications Exceeding Maximum Pressure and/or Temperature Indicated.*

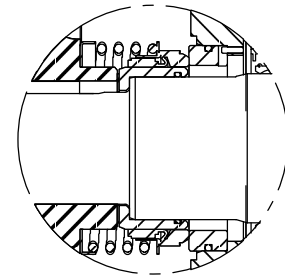
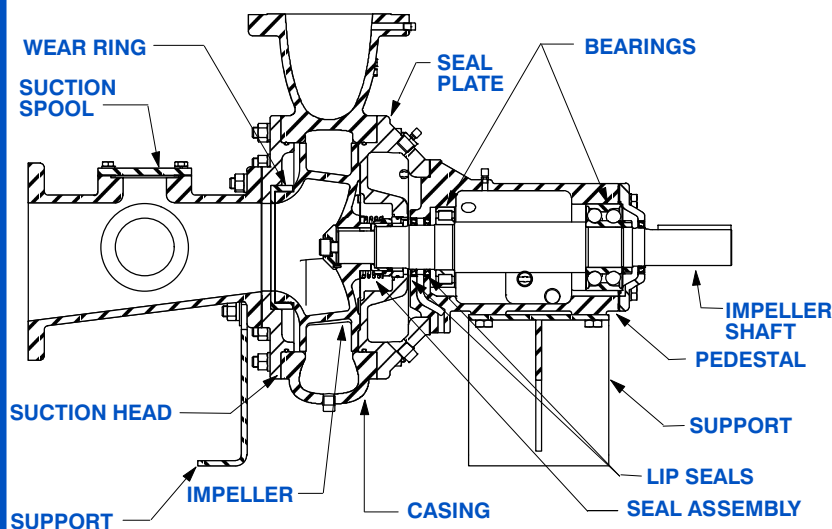
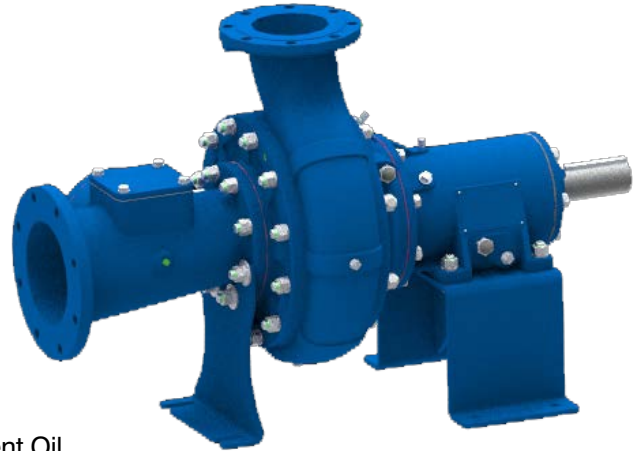

## SEAL DETAIL

Mechanical, Oil-Lubricated. Silicon Carbide Rotating Face and Stationary Seat. Fluorocarbon Elastomers (DuPont Viton® or Equivalent). Stainless Steel 316 Cage and Spring. Maximum Temperature of Liquid Pumped 160°F (71°C).\*



GORMAN-RUPP PUMPS

www.grpumps.com

Specifications Subject to Change Without Notice

Printed in U.S.A.

**Specification Data**

SECTION 65, PAGE 311

APPROXIMATE  
DIMENSIONS and WEIGHTS

NET WEIGHT: 775 LBS (351,5 KG)  
SHIPPING WEIGHT: 875 LBS (396,9 KG)  
EXPORT CRATE: 30 CU. FT. (0,9 CU. M.)

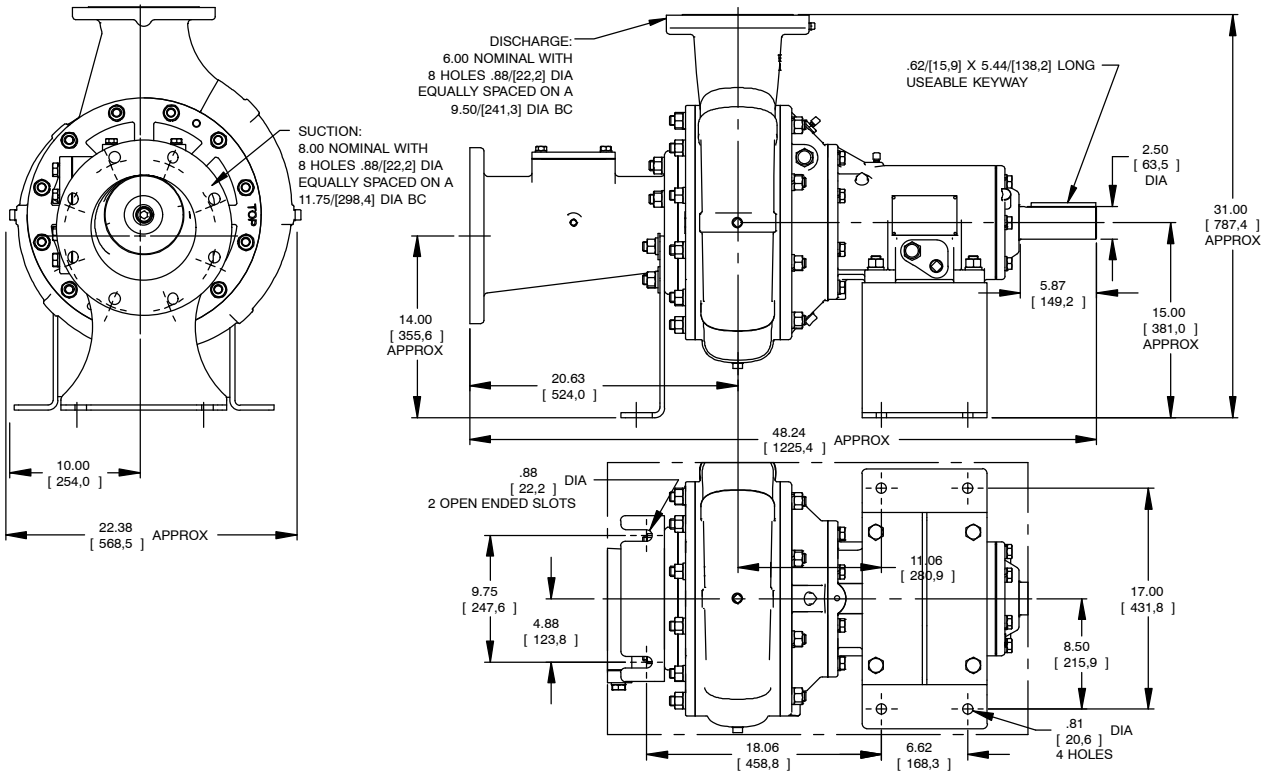

**MULTI-SPEED  
CURVE  
PERFORMANCE  
BASED ON  
WATER**

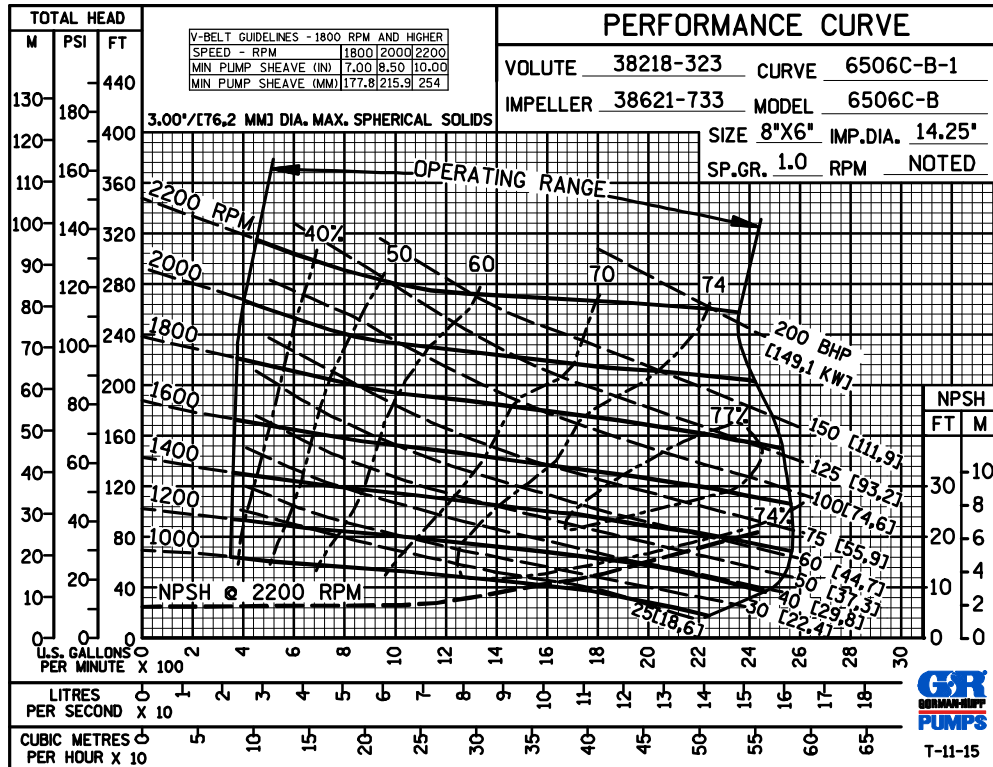

**GORMAN-RUPP PUMPS**

www.grpumps.com

Specifications Subject to Change Without Notice

Printed in U.S.A.

60 HERTZ  
PERFORMANCE  
BASED ON  
WATER  
TRIMMED  
IMPELLER

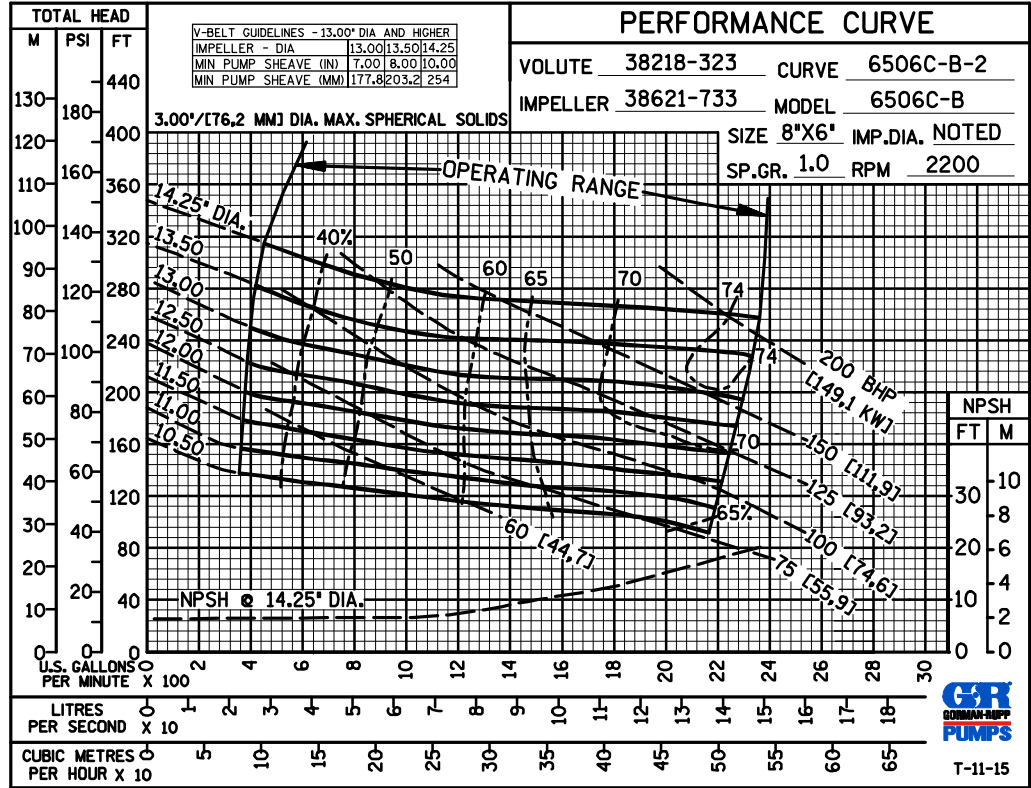

60 HERTZ  
PERFORMANCE  
BASED ON  
WATER  
TRIMMED  
IMPELLER

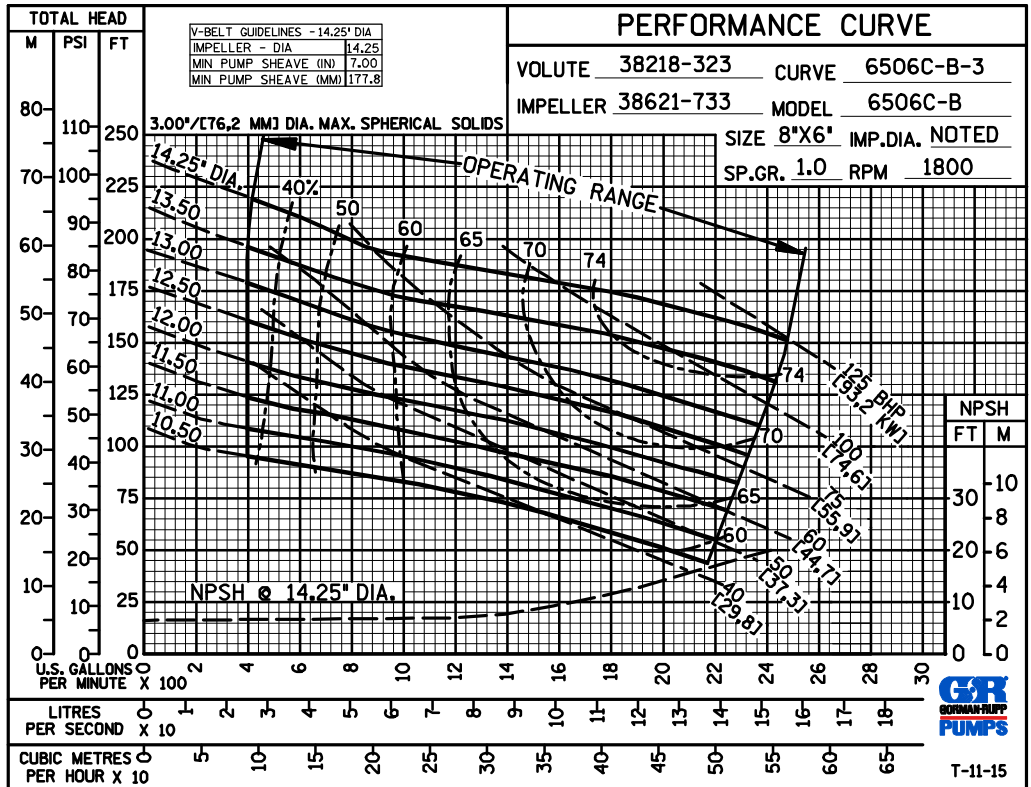

GORMAN-RUPP PUMPS

www.grpumps.com

Specifications Subject to Change Without Notice

Printed in U.S.A.

