

Standard Centrifugal Pump

Model 6506A31-B

Size 10" x 6"



PUMP SPECIFICATIONS

Size: 10" x 6" (254 mm x 152 mm) Flanged.

Casing: Ductile Iron 65-45-12.

Maximum Casing Pressure 231 psi (1593 kPa).*

Enclosed Type, Two Vane Impeller: Ductile Iron 65-45-12.

Handles 3" (76,2 mm) Diameter Spherical Solids.

Suction Head: Ductile Iron 65-45-12.

Suction Spool: Ductile Iron 65-45-12.

Impeller Shaft: Alloy Steel 4150.

Replaceable Wear Ring: Ductile Iron 65-45-12.

Pedestal: Gray Iron 30.

Seal Plate: Ductile Iron 65-45-12.

Shaft Sleeve: Stainless Steel 303/304.

Radial Bearing: Open Roller.

Thrust Bearing: Open Double Ball.

Bearing and Seal Cavity Lubrication: SAE 30 Non-Detergent Oil.

Gaskets: Vegetable Fiber, Red Rubber and Buna-N.

O-Rings: Buna-N.

Hardware: Standard Plated Steel.

Bearing and Seal Cavity Oil Level Sight Gauges.

**Consult Factory for Applications Exceeding Maximum Pressure and/or Temperature Indicated.*

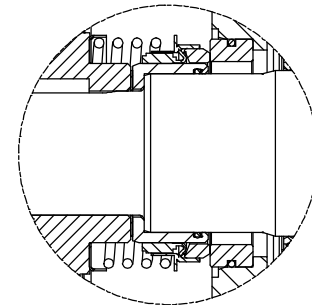
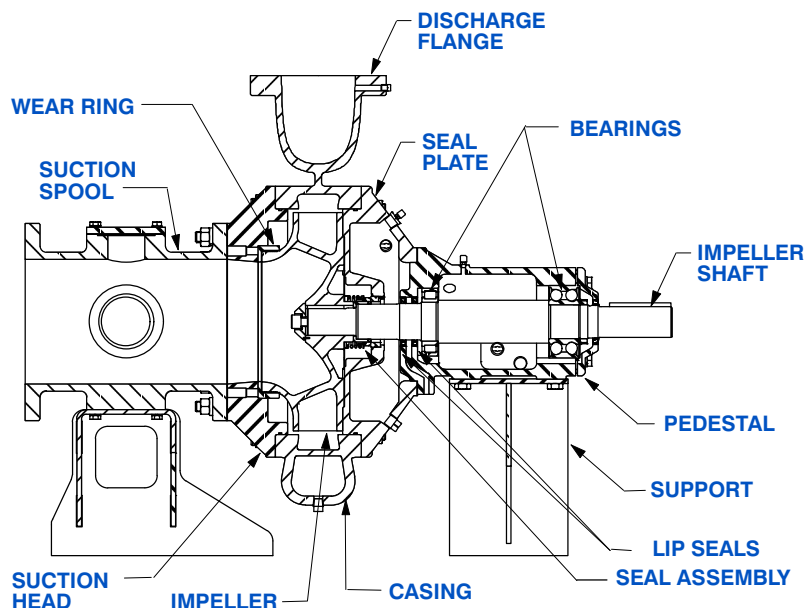
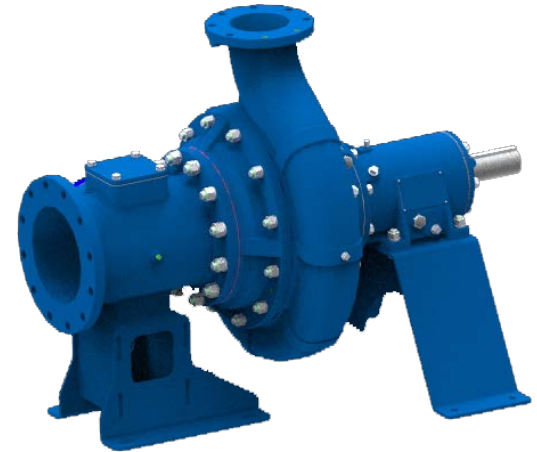

SEAL DETAIL

Mechanical, Oil-Lubricated. Silicon Carbide Rotating Face and Stationary Seat. Fluorocarbon Elastomers (DuPont Viton® or Equivalent). Stainless Steel 316 Cage and Stainless Steel 18-8 Spring. Maximum Temperature of Liquid Pumped 160° F (71° C).*



GORMAN-RUPP PUMPS

www.grpumps.com

Specifications Subject to Change Without Notice

Printed in U.S.A.

Specification Data

SECTION 65, PAGE 302

APPROXIMATE
DIMENSIONS and WEIGHTS

NET WEIGHT: 1053 LBS. (477,6 KG.)
SHIPPING WEIGHT: 1203 LBS. (545,6 KG.)
EXPORT CRATE: 61.3 CU. FT. (1,7 CU. M.)

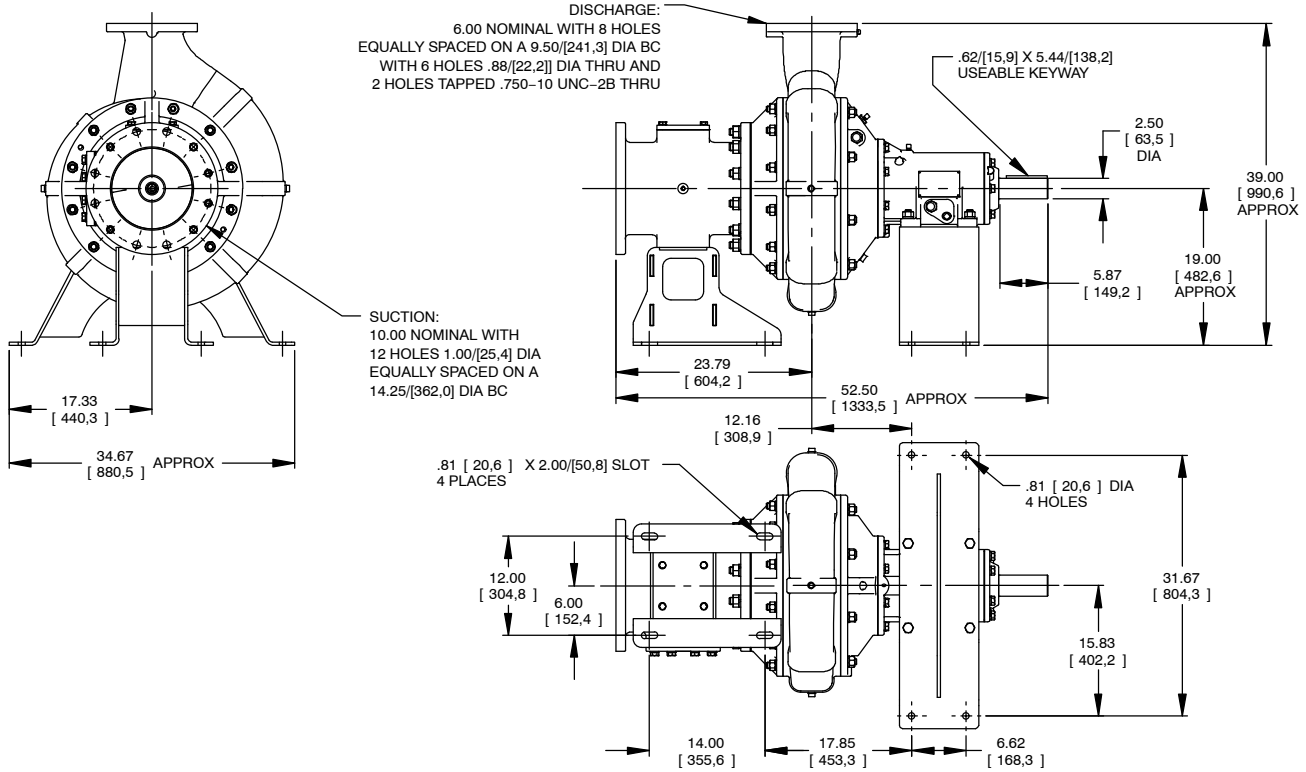

**MULTI-SPEED
CURVE
PERFORMANCE
BASED ON
WATER**

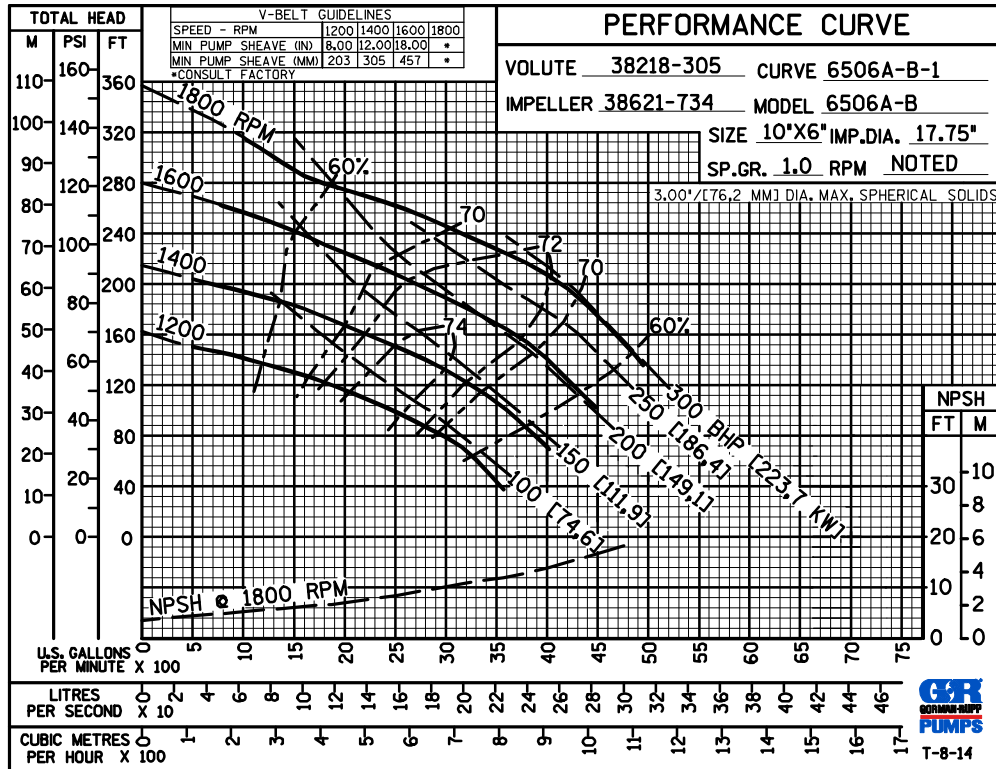

GORMAN-RUPP PUMPS

www.grpumps.com

Specifications Subject to Change Without Notice

Printed in U.S.A.

60 HERTZ
PERFORMANCE
BASED ON
WATER
TRIMMED
IMPELLER

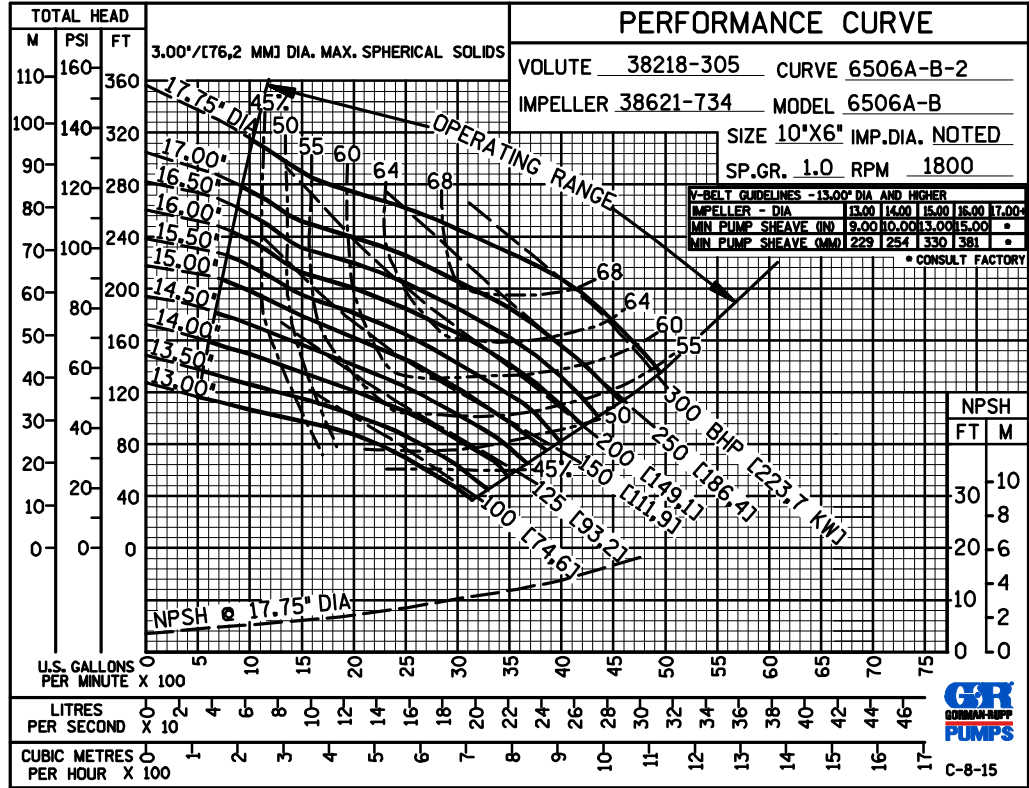

60 HERTZ
PERFORMANCE
BASED ON
WATER
TRIMMED
IMPELLER

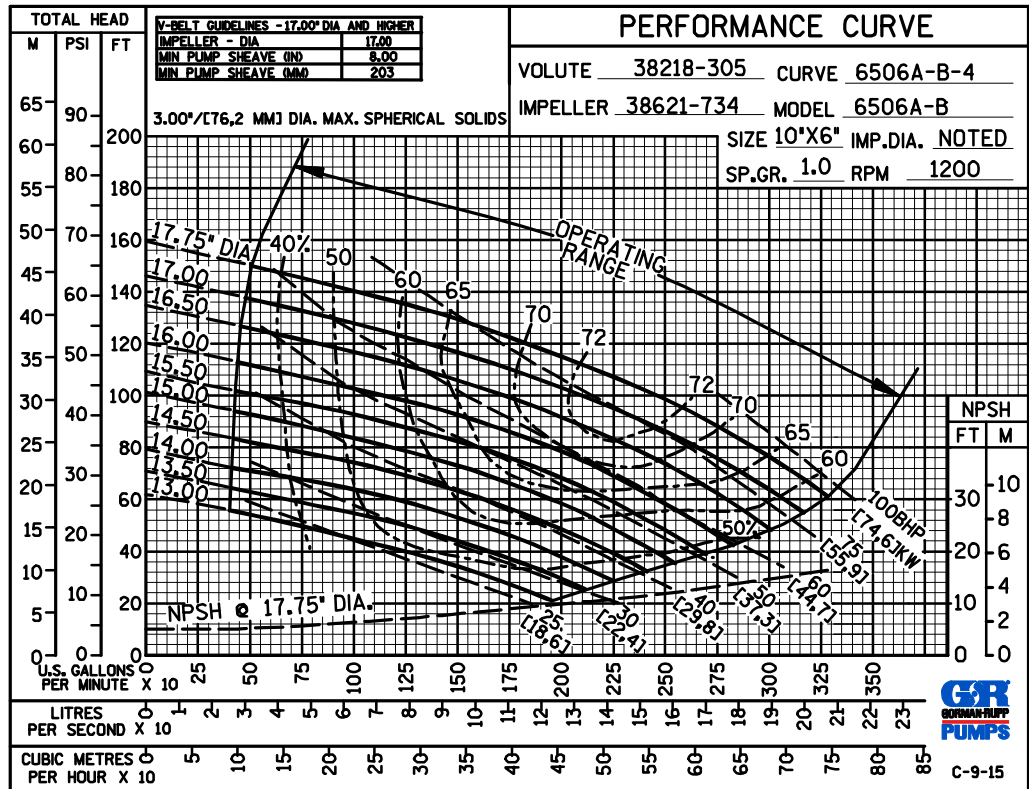

GORMAN-RUPP PUMPS

www.grpumps.com

Specifications Subject to Change Without Notice

Printed in U.S.A.

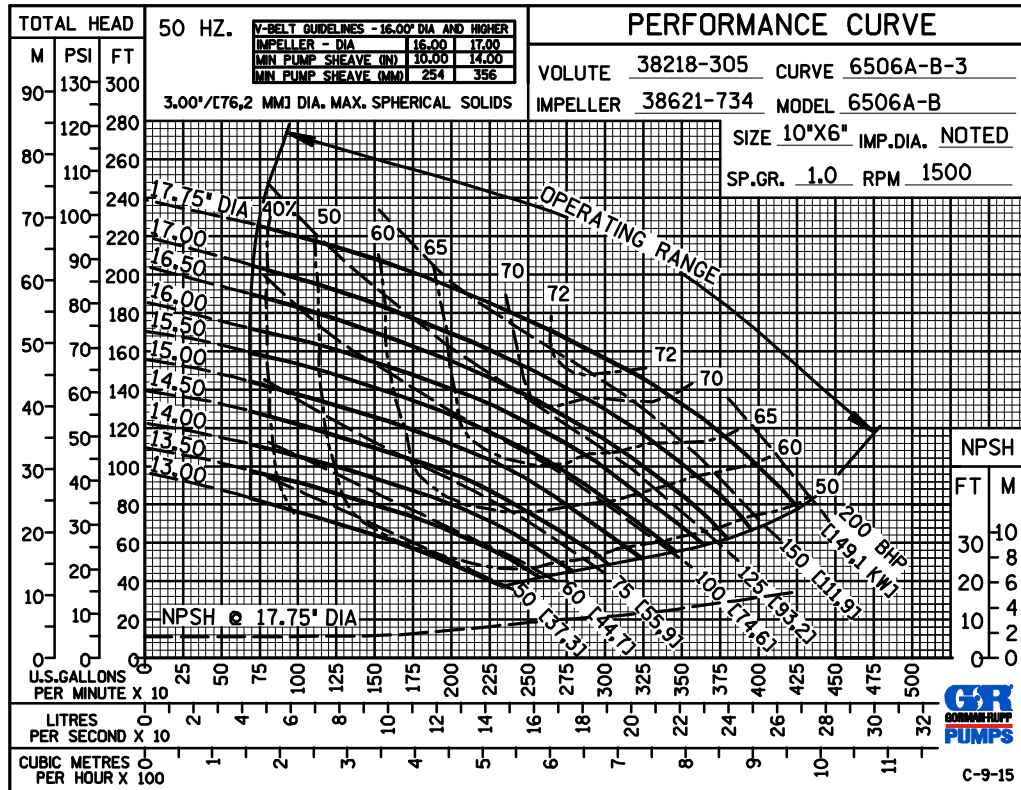

50 HERTZ
PERFORMANCE
BASED ON
WATER
TRIMMED
IMPELLER



GORMAN-RUPP PUMPS

www.grpumps.com

Specifications Subject to Change Without Notice

Printed in U.S.A.