



Standard Centrifugal Pump

Model 6403C60-B

Size 4" x 3"



PUMP SPECIFICATIONS

Size: 4" x 3" (101,6 mm x 76,2 mm) Flanged.

Casing: Ductile Iron 65-45-12.

Maximum Operating Pressure 61 psi (421 kPa).*

Impeller: Ductile Iron 65-45-12.

Handles 2 1/2" (63,5 mm) Diameter Spherical Solids.

Impeller Shaft: Alloy Steel 4150.

Replaceable Self Cleaning Wear Plate: Carbon Steel ASTM A36.

Shaft Sleeve: Alloy Steel 4130.

Seal Plate: Ductile Iron 65-45-12.

Bearing Housing: Gray Iron 30.

Radial Bearing: Open Single Row Ball.

Thrust Bearing: Open Single Row Ball.

Bearing and Seal Cavity Lubrication: SAE 30 Non-Detergent Oil.

Gaskets: Vegetable Fiber and Cork.

O-Rings: Buna-N. Fluorocarbon FKM, (Viton® or Equivalent)

Hardware: Standard Plated Steel.

Bearing and Seal Cavity Oil Level Sight Gauges.

Optional Equipment: Suction Spool w/Clean-out.



**Consult Factory for Applications Exceeding Maximum Pressure and/or Temperature Indicated.*

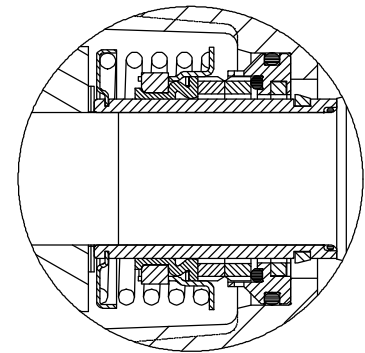
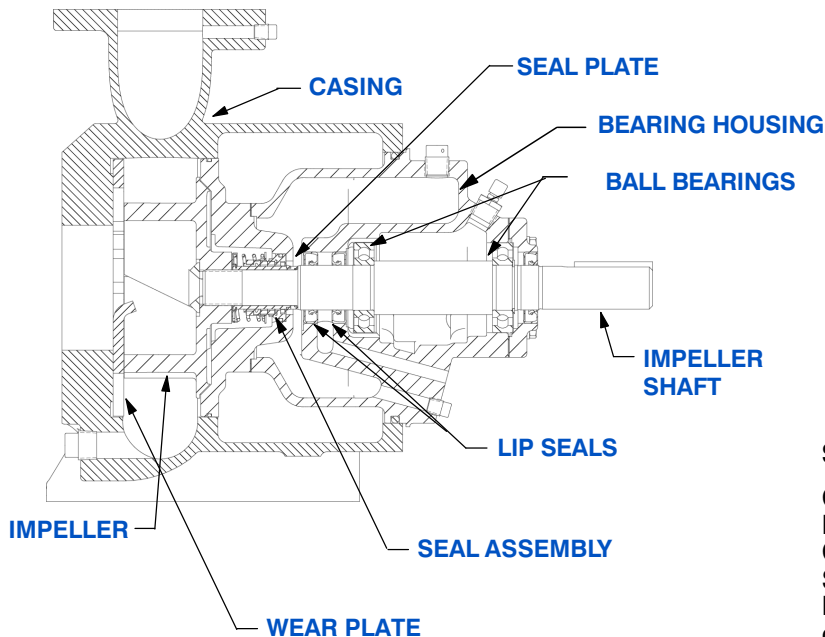

SEAL DETAIL

Cartridge Type, Mechanical, Oil-Lubricated, Double Floating, Self-Aligning. Silicon Carbide Rotating and Stationary Faces. Stainless Steel 316 Stationary Seat. Fluorocarbon Elastomers (DuPont Viton® or Equivalent). Stainless Steel 18-8 Cage and Spring. Maximum Temperature of Liquid Pumped, 160°F (71°C).*



GORMAN-RUPP PUMPS

www.grpumps.com

Specifications Subject to Change Without Notice

Printed in U.S.A.

Specification Data

SECTION 64, PAGE 310

APPROXIMATE DIMENSIONS and WEIGHTS

NET WEIGHT: 355 LBS. (161 KG.)*
SHIPPING WEIGHT: 445 LBS. (202 KG.)*
EXPORT CRATE: 10.0 CU. FT. (0,28 CU. M.)

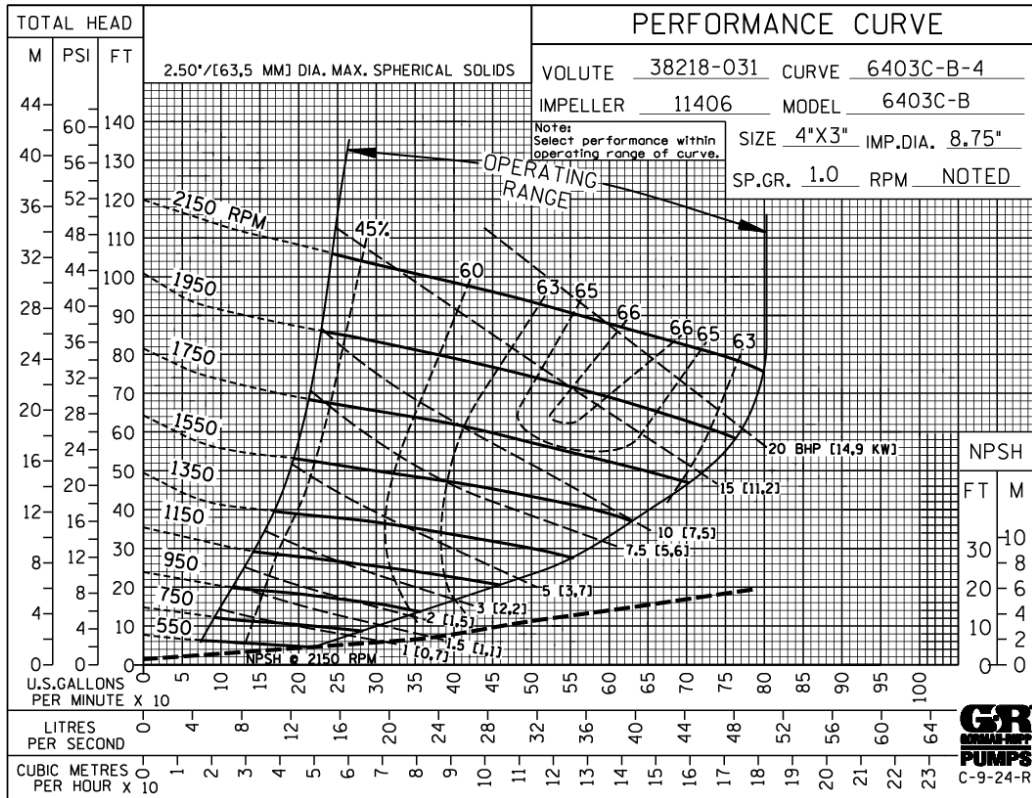
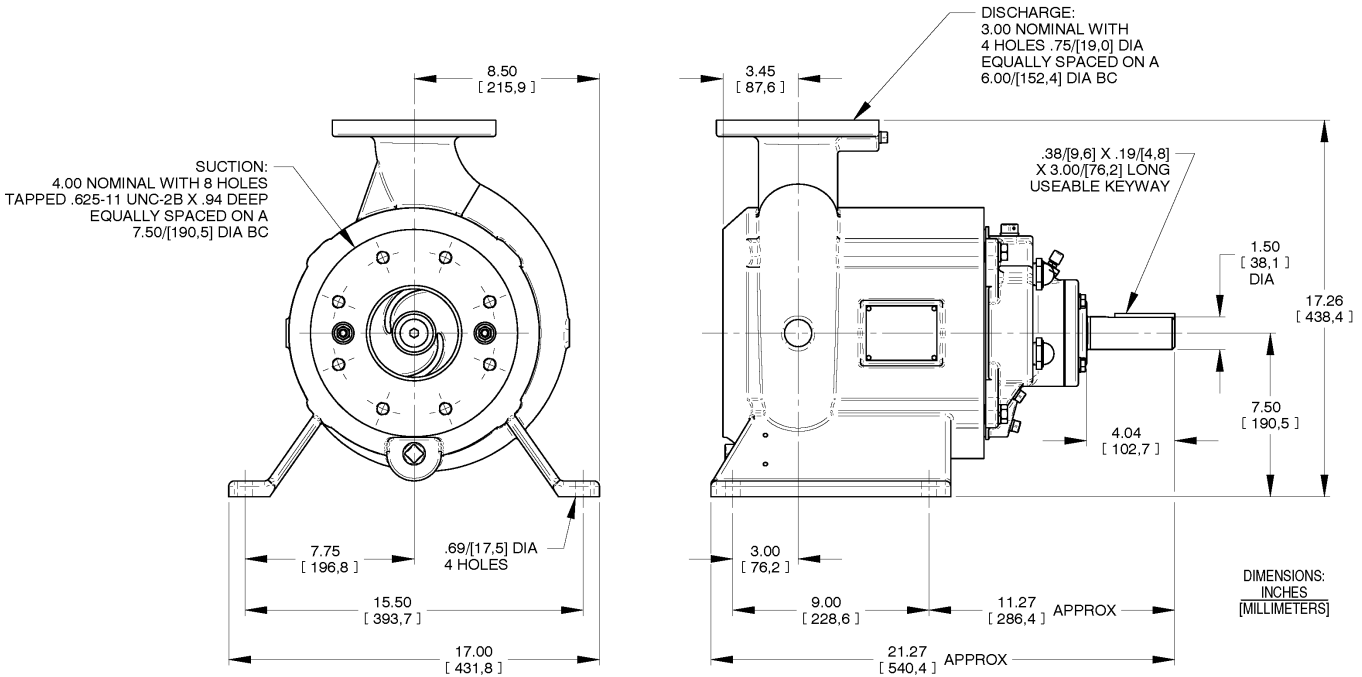

GORMAN-RUPP PUMPS

www.grpumps.com

Specifications Subject to Change Without Notice

Printed in U.S.A.