

D

Self Priming Centrifugal Pump

Basic Pedestal

Model T3A24-B

Size 3" x 3"



PUMP SPECIFICATIONS

Size: 3" [76,2 mm] x 3" [76,2 mm] N.P.T.-Female

Casing: Gray Iron No. 30

(Maximum Operating Pressure 90 psi. [620 kPa])

Impeller: Open Type, Two Vanes, Stainless Steel No. 316

(Handles 2 1/2" [63,5 mm] Dia. Spherical Solids)

Impeller Shaft: Stainless Steel No. 17-4 PH

Wear Plate-Replaceable: Stainless Steel No. 316

Cover Plate-Removable: Gray Iron No. 30 (30 lbs. [14 KG.])

Bearing Housing: Gray Iron No. 30

Seal Plate: Stainless Steel No. 316

Flap Valve: Neoprene

Radial Bearing: Open Ball

Thrust Bearing: Open Ball with Snap Ring

Bearing Lubrication: Oil

Flanges: Gray Iron No. 30

Gaskets: Compressed Synthetic Fibers and Teflon

O-Rings: Buna-N

Hardware-Internal Wetted: Stainless Steel No. 316

Hardware-External: Standard Plated Steel

Standard Equipment:

Oil Level Sight Gauge

Pressure Relief Valve: Stainless Steel No. 316

Optional Equipment:

Air Release Valve: Gray Iron No. 30

Suction and Discharge Flanged Spool:

Gray Iron No. 30

Casing Heater: 120V or 240V

High Pump Temperature Shutdown

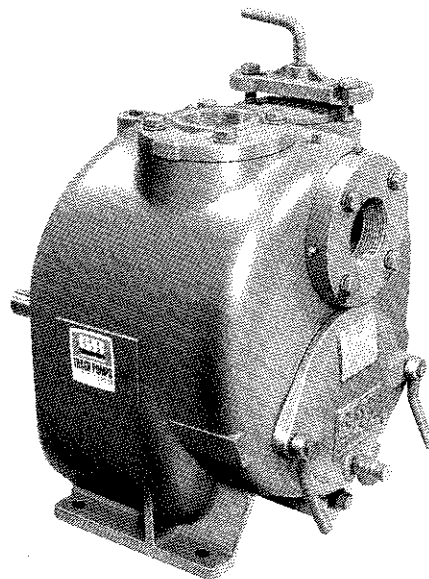

SEAL MODEL T3A24-B

Mechanical Oil-Lubricated Double Floating Self-Aligning. Rotating and Stationary Faces are Tungsten Titanium Carbide. Stationary Seat is Stainless Steel No. 316. Elastomers are Viton. Cage and Spring are Stainless Steel No. 18-8. Maximum Temperature of Liquid Pumped, 160°F [71°C]*.

* Consult Factory for applications with liquids in excess of temperature indicated.

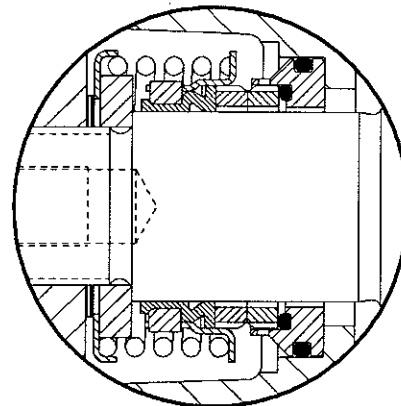
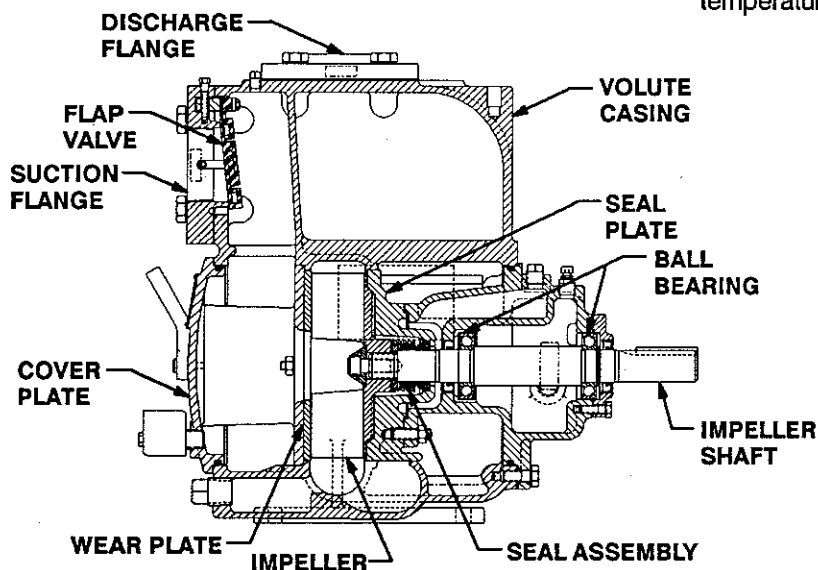

THE GORMAN-RUPP COMPANY • MANSFIELD, OHIO

GORMAN-RUPP OF CANADA LIMITED • ST. THOMAS, ONTARIO, CANADA

Printed in U.S.A.

Specification Data

SECTION 55, PAGE 1025

OVERALL DIMENSIONS
and
WEIGHTS APPROXIMATE

NET WEIGHT: 444 LBS. [201 KG.]
SHIPPING WEIGHTS: 454 LBS. [206 KG.]
EXPORT CRATE: 12.7 CU. FT. [36 CU. M.]

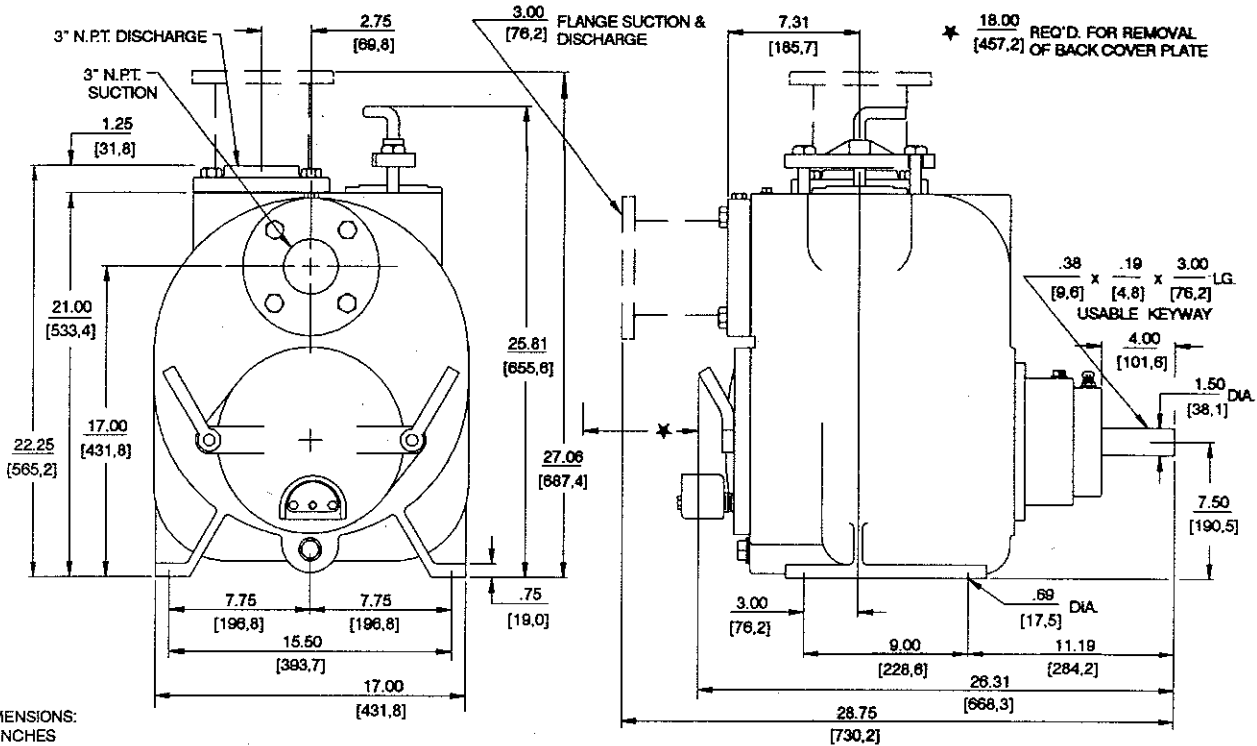

DIMENSIONS:
INCHES
[MILLIMETERS]

NOTE: OPTIONAL SUCTION & DISCHARGE SPOOLS AVAILABLE

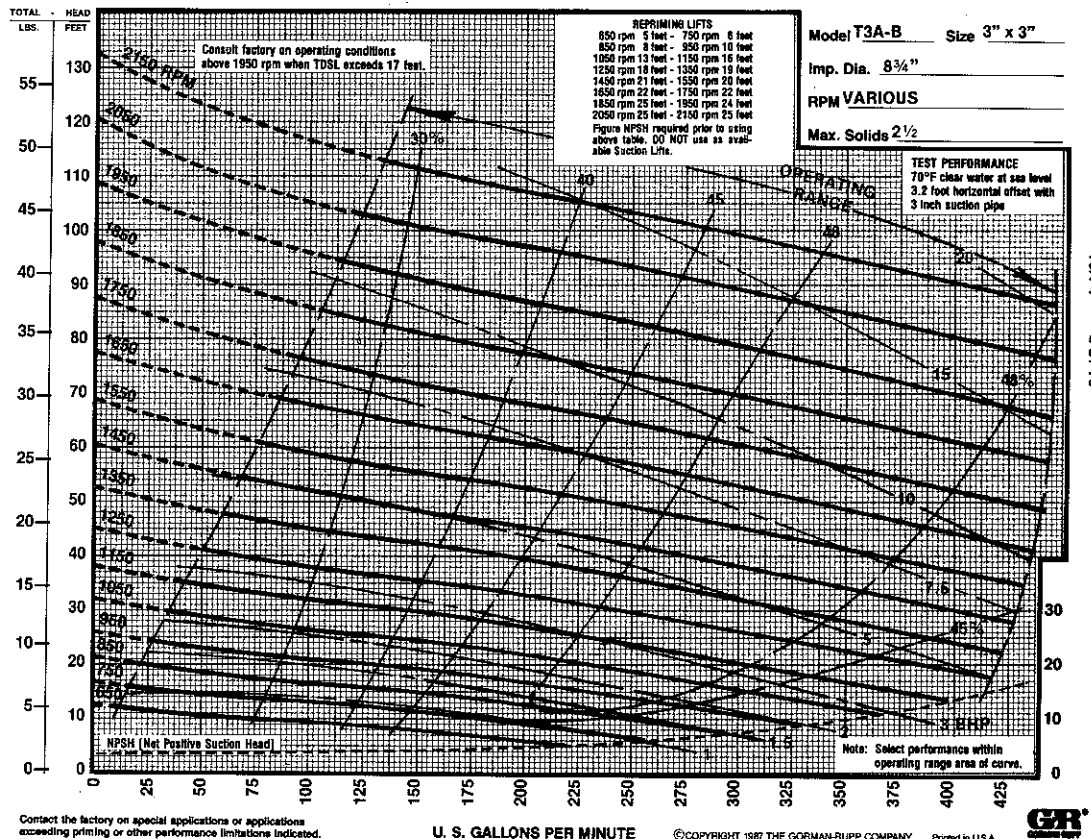

PERFORMANCE CHART NO. T3A-4 2-21-79



THE GORMAN-RUPP COMPANY • MANSFIELD, OHIO

GORMAN-RUPP OF CANADA LIMITED • ST. THOMAS, ONTARIO, CANADA

Printed in U.S.A.