



# Stainless Steel Self Priming Centrifugal Pump

Basic Pedestal  
Model 13A59-B  
Size 3" x 3"

## PUMP SPECIFICATIONS

**Size:** 3" x 3" NPT (76 mm x 76 mm) - Female.  
**Casing:** Stainless Steel Alloy 20. Maximum Operating Pressure 66 psi (4,6 kg/cm<sup>2</sup>).\*  
**Open Type, Two Vane Impeller:** Stainless Steel Alloy 20. Handles 1 1/2" (38,1 mm) Diameter Spherical Solids.  
**Impeller Shaft:** Stainless Steel Alloy 20.  
**Replaceable Wear Plate:** Stainless Steel Alloy 20.  
**Removable Cover Plate:** Stainless Steel Alloy 20; 16 lbs. (7 kg).  
**Pedestal:** Gray Iron No. 30.  
**Seal Plate:** Stainless Steel Alloy 20.  
**Seal Sleeve:** Stainless Steel Alloy 20.  
**Flap Valve:** Fluorocarbon Elastomers (DuPont Viton® or Equivalent); Stainless Steel Alloy 20.  
**Radial/Thrust Bearing:** Open Single Ball.  
**Bearing Lubrication:** Oil.  
**Flanges:** Stainless Steel Alloy 20.  
**Gaskets:** PTFE, Compressed Synthetic Fibers, and Fluorocarbon (DuPont Viton® or Equivalent).  
**Internal Wetted Hardware:** Stainless Steel Alloy 20.  
**External Hardware:** Stainless Steel No. 316.

**Optional Equipment:** Consult Factory.

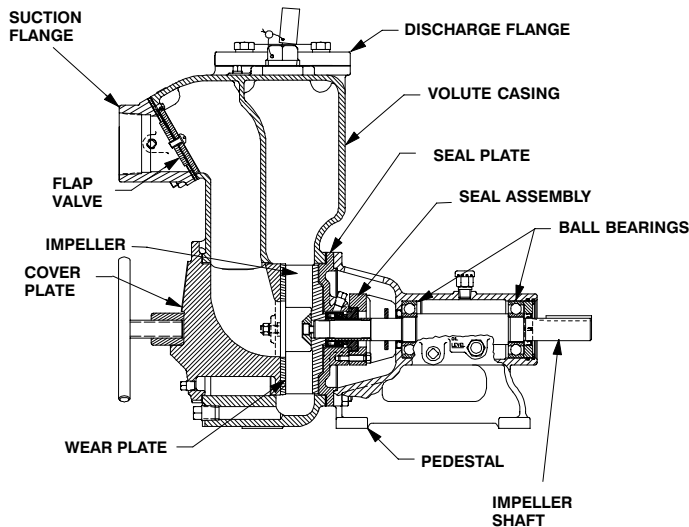

## 13A59-B SEAL DETAIL

Type 9, Mechanical, Self-Lubricated. Silicon Carbide Rotating and Stationary Faces. PTFE Elastomers. Stainless Steel No. 316 Cage and Spring. Maximum Temperature of Liquid Pumped, 160°F (71°C).\*

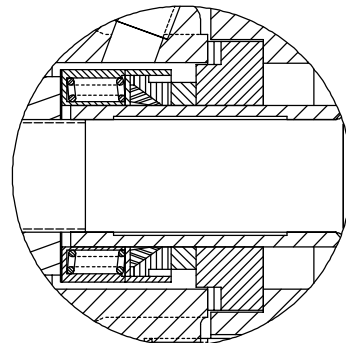

\*Consult Factory for Applications Exceeding Maximum Pressure and/or Temperature Indicated.



THE GORMAN-RUPP COMPANY • MANSFIELD, OHIO

GORMAN-RUPP OF CANADA LIMITED • ST. THOMAS, ONTARIO, CANADA

Specifications Subject to Change Without Notice

Printed in U.S.A.

**Specification Data**

SECTION 55, PAGE 406

APPROXIMATE DIMENSIONS and WEIGHTS

**NET WEIGHT: 225 LBS. (102 KGS.)**  
**SHIPPING WEIGHT: 243 LBS. (110 KGS.)**  
**EXPORT CRATE SIZE: 7.7 CU. FT. (0,2 CU. M.)**

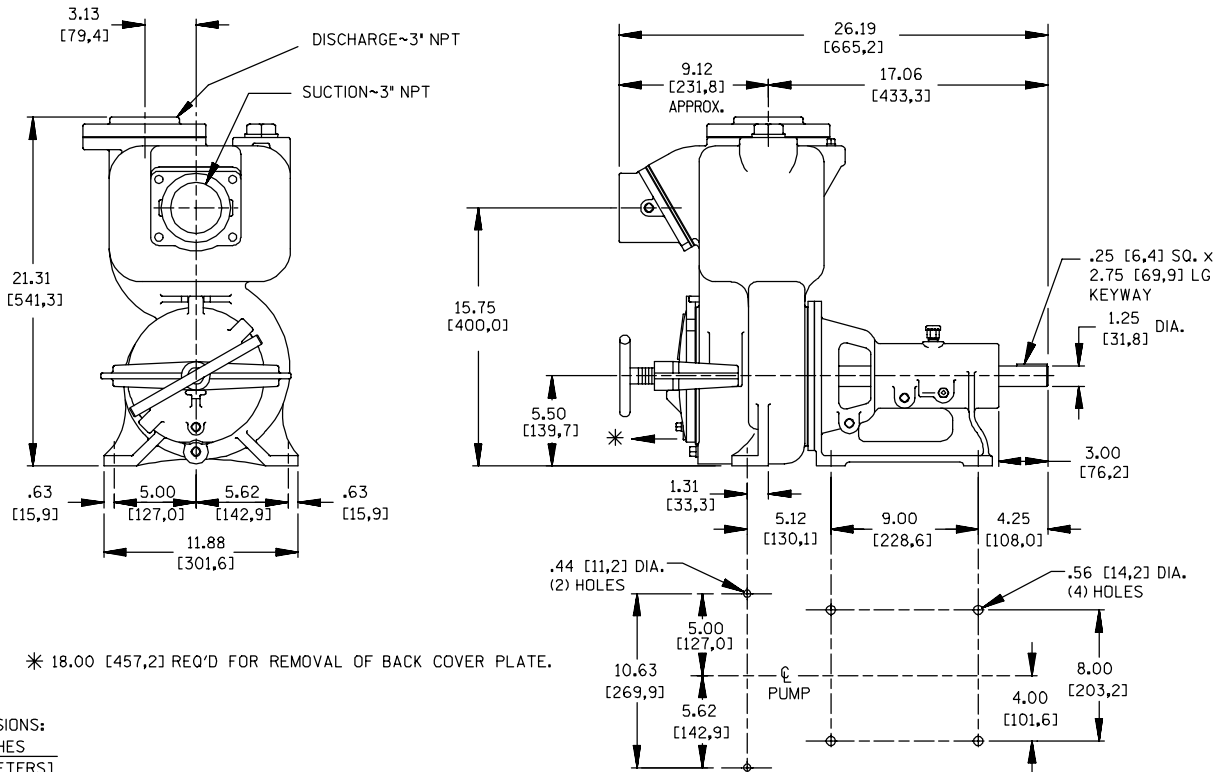

\* 18.00 [457,2] REQ'D FOR REMOVAL OF BACK COVER PLATE.

DIMENSIONS:  
 INCHES  
 [MILLIMETERS]

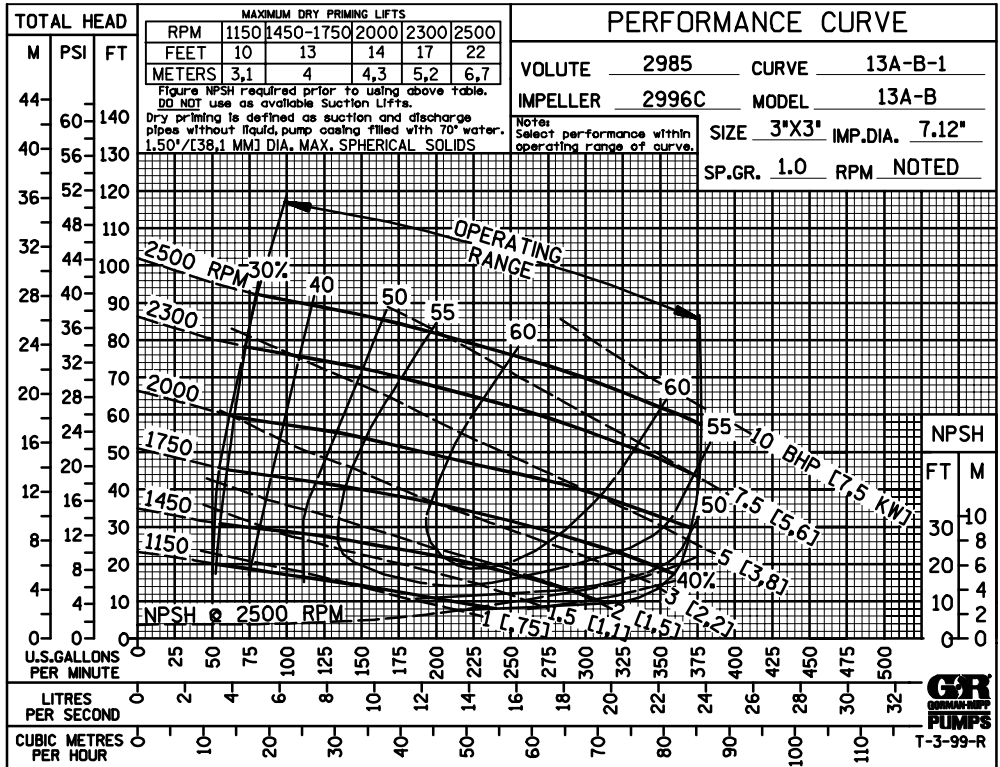

THE GORMAN-RUPP COMPANY • MANSFIELD, OHIO

GORMAN-RUPP OF CANADA LIMITED • ST. THOMAS, ONTARIO, CANADA

Specifications Subject to Change Without Notice

Printed in U.S.A.