

ACDEGU

Self Priming Centrifugal Pump

Gasoline Engine Driven

Model 12A1-11

Size 2" x 2"

CERTIFIED
PERFORMANCE

The Manufacturer of this pump certifies that it was manufactured in accordance with the standards of the Contractors Pump Bureau.

10MTC

Total Head		Capacity Of Pump In U.S. Gallons Per Minute At Continuous Performance				
P.S.I.	Feet					
47.7	110	26	26	26	26	26
43.4	100	48	48	48	48	48
39.0	90	69	71	71	71	71
34.7	80	75	91	91	91	91
30.3	70	79	103	110	110	110
26.0	60	80	106	126	126	126
21.7	50	80	109	135	140	140
17.3	40	80	109	137	148	150
13.0	30	80	107	138	154	160
8.7	20	80	118	138	155	172
Suction Lift		25'	20'	15'	10'	5'

**WARNING!**

Do not use in explosive atmosphere or for pumping volatile flammable liquids.

PUMP SPECIFICATIONS

Size: 2" x 2" NPT (51 mm x 51 mm) - Female.**Casing:** Die Cast Aluminum Alloy No. 380. Maximum Operating Pressure 77 psi (45,4 kg/cm²).***Open Type, Two Vane Impeller:** Ductile Iron No. 65-45-12. Handles 1" (25,4 mm) Diameter Spherical Solids.**Volute Scroll:** Gray Iron No. 30.**Seal:** Mechanical, Self-Lubricated. Silicon Carbide Rotating and Stationary Faces. Fluorocarbon Elastomers (DuPont Viton® or Equivalent). Stainless Steel Cage and Spring. Maximum Temperature of Liquid Pumped, 160°F (71°C).*

* Consult Factory for Applications Exceeding Maximum Pressure and/or Temperature Indicated.

Flap Valve: EPDM Rubber w/Steel Reinforcement.**O-Rings:** EPDM Rubber.**Fill/Drain Plugs:** Plastic.**Internal Wetted Hardware:** Stainless Steel.**External Hardware:** Standard Plated Steel.**Strainer.****Optional Equipment:** Roll Cage w/Rubber Feet. Two-Wheel Truck Assembly For Use With Roll Cage, with 10" x 2.75" (254 mm x 70 mm) Semi-Pneumatic Tires.

ENGINE SPECIFICATIONS

Model: Briggs & Stratton Model 11.**Type:** Single Cylinder, Four Cycle, Air Cooled, Overhead Valve, Gasoline Engine.**Displacement:** 11.57 Cu. In. (190 cc).**Carburetor:** Side Draft Venturi.**Governor:** Mechanical.**Lubrication:** Splash System.**Air Cleaner:** Paper Element.**Oil Reservoir:** 1.25 U.S. Pts. (0,6 liter).**Fuel Tank:** 3.0 U.S. Qts. (2.8 liter).**Full Load Operating Time:** 2.1 Hrs.**Starter:** Rope Rewind.**Standard Equipment:** Muffler w/Guard; Manual Stop; Manual Throttle Control w/Top Speed Limit; Manual Choke; Magnetron Ignition. Dual Oil Fill/Drain Plugs.

BRIGGS & STRATTON

PUBLISHED PERFORMANCE @ 3600 RPM:

Maximum Continuous BHP 5.1 (3,8 kW)

Maximum Dynamic BHP 5.5 (4,1 kW)



THE GORMAN-RUPP COMPANY • MANSFIELD, OHIO

GORMAN-RUPP OF CANADA LIMITED • ST. THOMAS, ONTARIO, CANADA

Specifications Subject to Change Without Notice

Printed in U.S.A.

Specification Data

APPROXIMATE
DIMENSIONS and WEIGHTS

NET WEIGHT: 70 LBS. (32 KG.)
 SHIPPING WEIGHT: 75 LBS. (34 KG.)
 EXPORT CRATE: 5.6 CU. FT. (0,16 CU. M.)
 OPTIONAL ROLL CAGE: ADD 10 LBS. (4,5 KG.)
 OPTIONAL WHEEL KIT: ADD 25 LBS. (11,3 KG.)

SECTION 45, PAGE 260

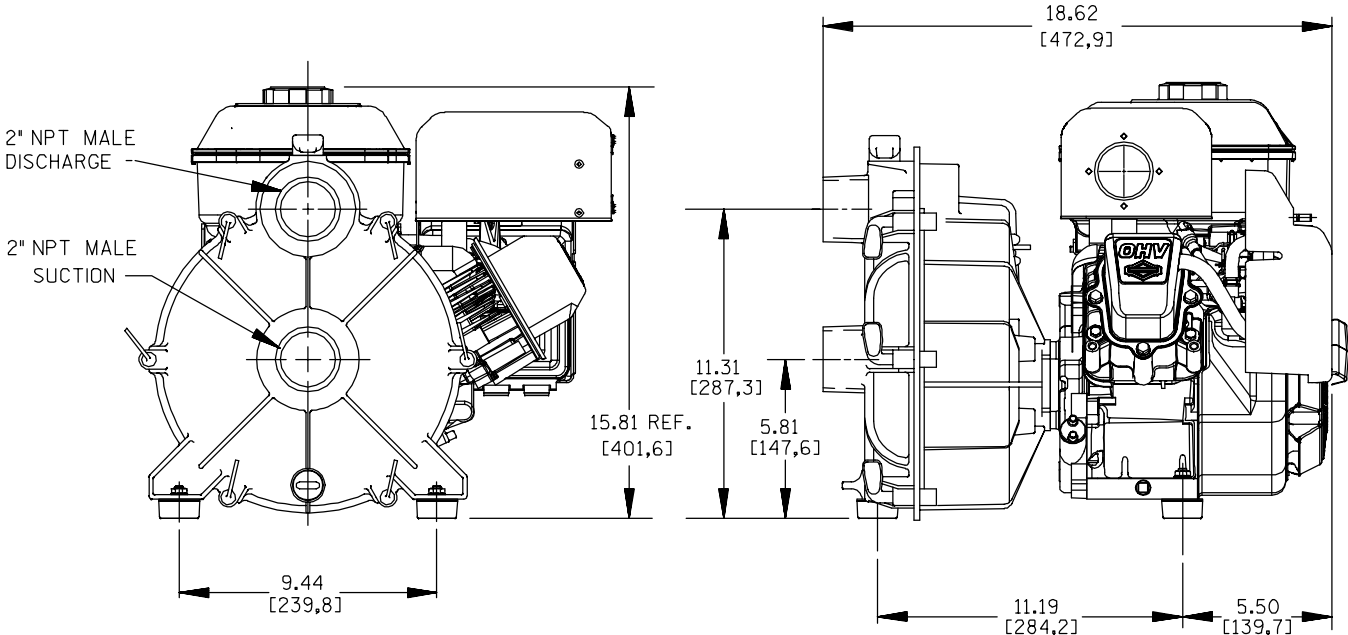

DIMENSIONS:
INCHES
[MILLIMETERS]

POWERED BY BRIGGS & STRATTON 5.5 HP GASOLINE ENGINE

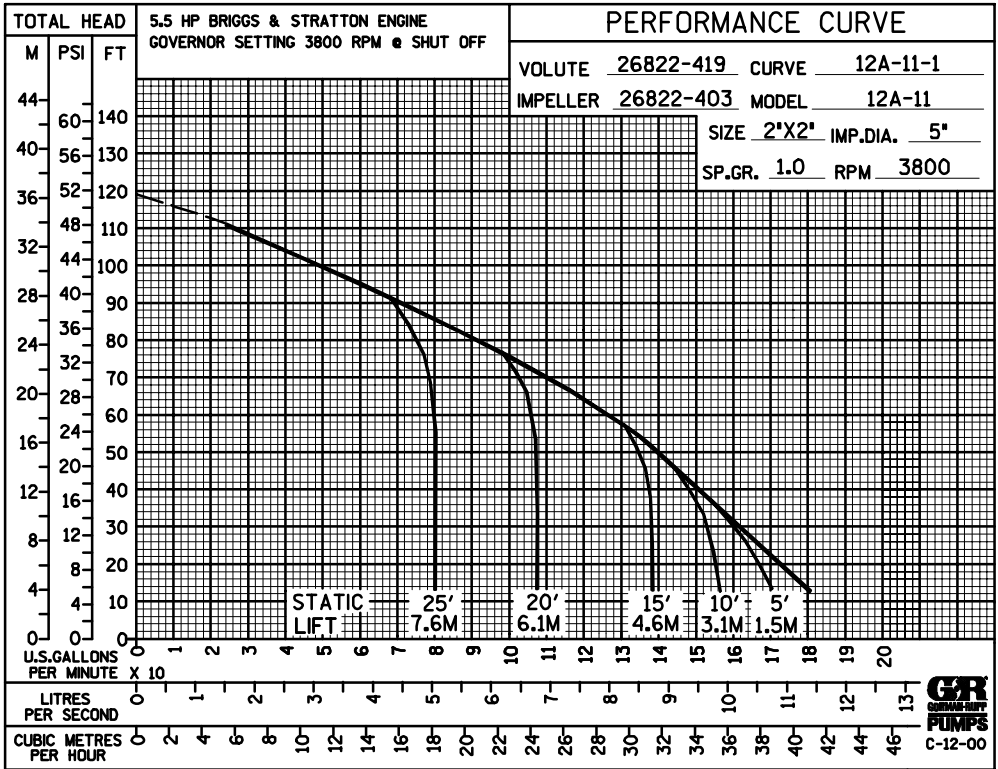

THE GORMAN-RUPP COMPANY • MANSFIELD, OHIO

GORMAN-RUPP OF CANADA LIMITED • ST. THOMAS, ONTARIO, CANADA

Specifications Subject to Change Without Notice

Printed in U.S.A.