



# Priming Assisted Centrifugal Pump

## Model PAH4A60C-B

### Size 6" x 4"



#### PUMP SPECIFICATIONS

**Size:** 6" x 4" (152 mm x 102 mm) Flanged.

**Casing:** Ductile Iron 65-45-12.

Maximum Operating Pressure 200 psi (1379 kPa).\*

**Enclosed Type, Two Vane Impeller:** Ductile Iron 65-45-12.

Handles 3" (76,2 mm) Diameter Spherical Solids.

**Suction Head:** Gray Iron 30.

**Suction Spool:** Gray Iron 30.

**Impeller Shaft:** Alloy Steel 4150M.

**Externally Adjustable, Replaceable Wear Ring:** Ductile Iron 65-45-12.

**Pedestal:** Gray Iron 30.

**Seal Plate:** Gray Iron 30.

**Shaft Sleeve:** Stainless Steel 303/304.

**Priming Chamber:** Gray Iron 30 Housing w/Stainless Steel Float and Linkage.

**Discharge Check Valve:** Ductile Iron Housing with Welded Nickel Seat and Buna-N Flapper.

**Radial Bearing:** Open Roller.

**Thrust Bearing:** Open Double Ball.

**Bearing Cavity Lubrication:** Lithium EP2 Grease.

**Gaskets:** Buna-N and Red Rubber.

**O-Rings:** Buna-N.

**Hardware:** Standard Plated Steel.

**Seal Cavity Oil Level Sight Gauges.**

\* Consult Factory for Applications Exceeding Maximum Pressure and/or Temperature Indicated.

**Standard Equipment:** Belt Driven Air Compressor. Strainer.

**Optional Equipment:** Base. NPT Threaded Flange Kit. Coupling. TEFC Motor. Suction Vacuum and Discharge Pressure Gauge Kit.

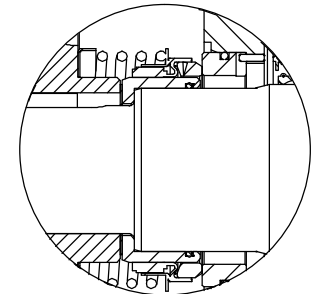
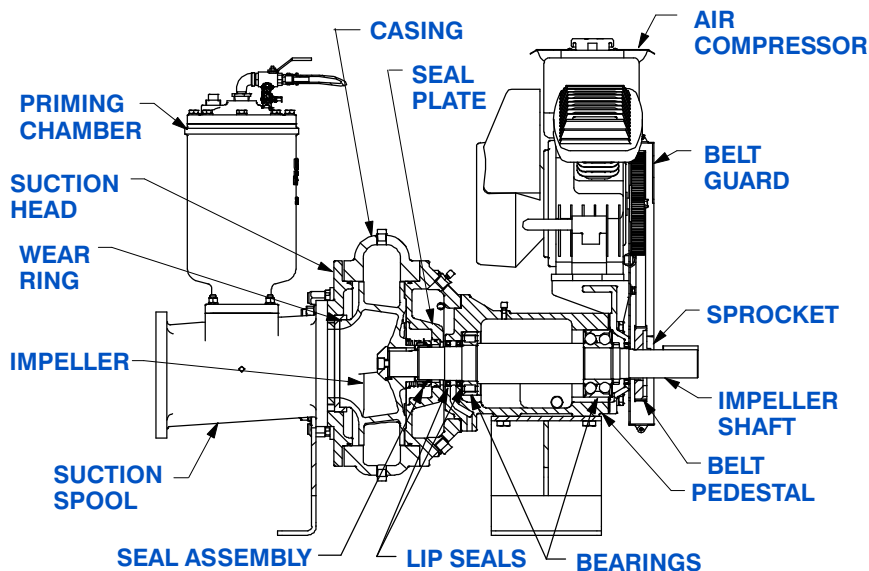

#### SEAL DETAIL

Mechanical, SAE 30 Non-Detergent Oil-Lubricated. Silicon Carbide Rotating Face and Stationary Seat. Fluorocarbon Elastomers (DuPont Viton® or Equivalent). Stainless Steel 316 Cage and Stainless Steel 18-8 Spring. Maximum Temperature of Liquid Pumped 160°F (71°C).\*



## GORMAN-RUPP PUMPS

www.grpumps.com

Specifications Subject to Change Without Notice

Printed in U.S.A.

**Specification Data**

**SECTION 43, PAGE 220**

APPROXIMATE  
DIMENSIONS and WEIGHTS

**NET WEIGHT: 1010 LBS. (377 KG.)**  
**SHIPPING WEIGHT: 1230 LBS. (459 KG.)**  
**EXPORT CRATE SIZE: 93 CU. FT. (2,6 CU. M.)**

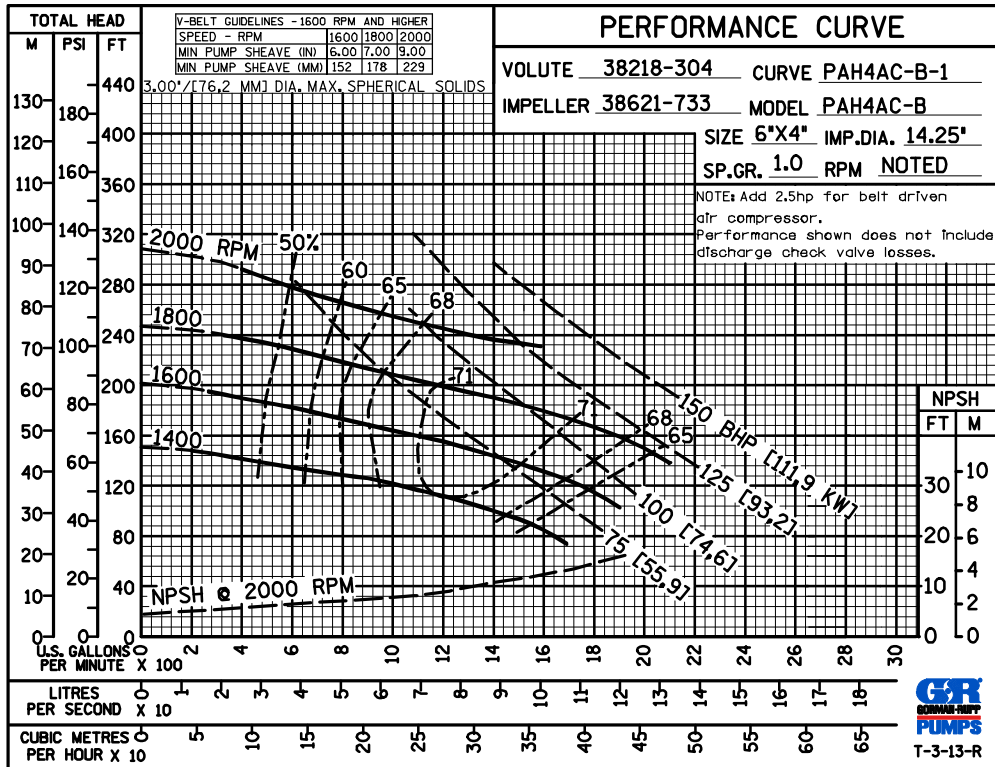
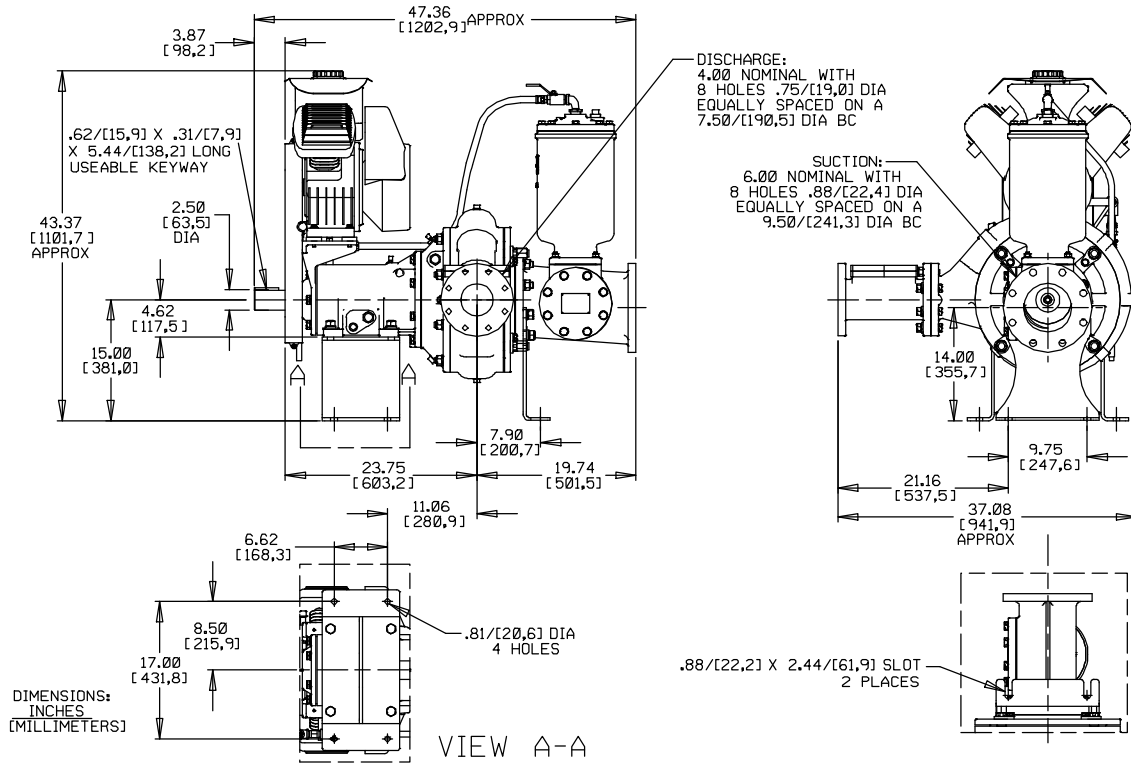

**GORMAN-RUPP PUMPS**

www.grpumps.com

Specifications Subject to Change Without Notice

Printed in U.S.A.

PERFORMANCE  
BASED ON  
WATER  
TRIMMED  
IMPELLER

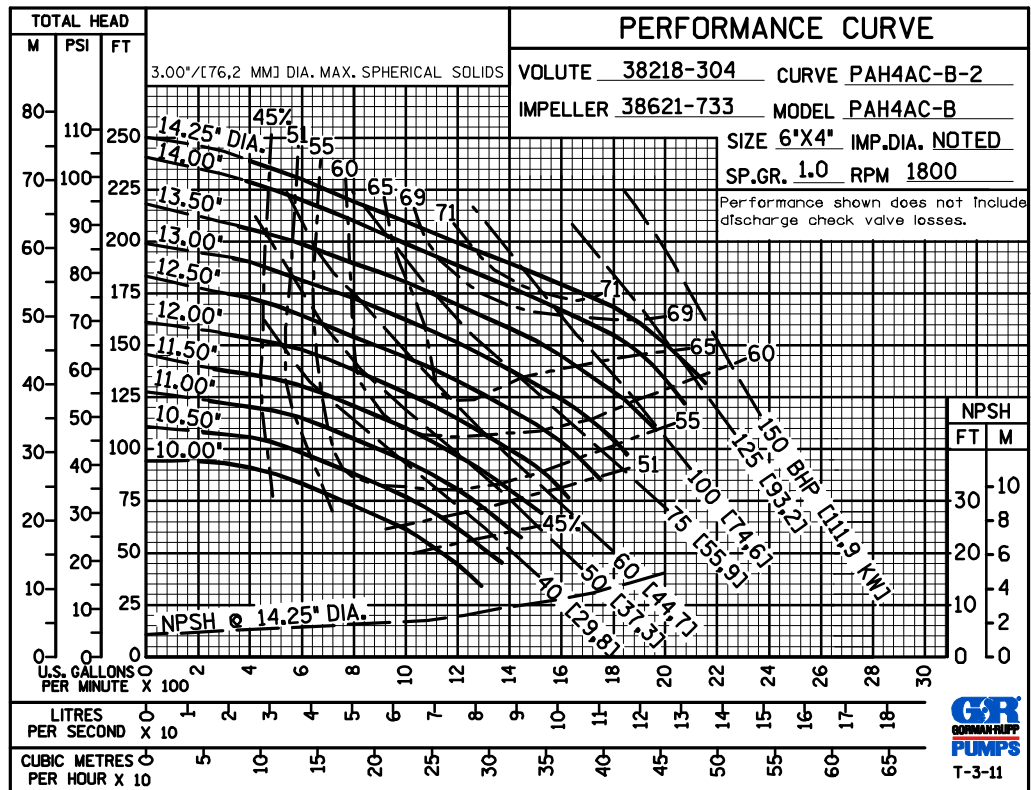

GORMAN-RUPP PUMPS

www.grpumps.com

Specifications Subject to Change Without Notice

Printed in U.S.A.