



# Priming Assisted Centrifugal Pump w/Autostart Model PAH4E60-6068H Size 6" x 4"



Total Head		Capacity of Pump in U.S. Gallons per Minute (GPM) at Continuous Performance				
P.S.I.	Feet					
180.3	416	440	440	—	—	—
173.4	400	520	600	—	—	—
156.1	360	600	820	—	—	—
138.7	320	660	870	980	980	980
121.4	280	700	910	1105	1280	1395
104.0	240	730	940	1140	1310	1440
86.7	200	740	960	1160	1340	1470
69.4	160	760	980	1180	1350	1495
52.0	120	770	995	1200	1365	1515
34.7	80	785	1010	1210	1380	1530
17.3	40	800	1020	1225	1400	1550
<b>Suction Lift</b>		<b>25'</b>	<b>20'</b>	<b>15'</b>	<b>10'</b>	<b>5'</b>



**PUMP SPECIFICATIONS**

**Size:** 6" x 4" (152 mm x 102 mm) Flanged.  
**Casing:** Ductile Iron 65-45-12.  
 Maximum Casing Pressure 283 psi (1951 kPa).\*  
 Maximum Operating Pressure 250 psi (1723 kPa) at Temperatures up to 100°F (37°C) Based on System Component Limitations.\*  
**Enclosed Type, Two Vane Impeller:** Ductile Iron 65-45-12.  
 Handles 3" (76,2 mm) Diameter Spherical Solids.  
**Suction Head:** Gray Iron 30.  
**Suction Spool:** Gray Iron 30.  
**Impeller Shaft:** Alloy Steel 4150M.  
**Replaceable Wear Ring:** Ductile Iron 65-45-12.  
**Bearing Pedestal:** Gray Iron 30.  
**Seal Plate:** Gray Iron 30.  
**Seal:** Mechanical, SAE 30 Non-Detergent Oil-Lubricated. Silicon Carbide Rotating Face and Stationary Seat. Fluorocarbon Elastomers (DuPont Viton® or Equivalent). Stainless Steel 316 Cage and Stainless Steel 18-8 Spring. Maximum Temperature of Liquid Pumped 160°F (71°C).\*  
**Shaft Sleeve:** Stainless Steel 303/304.  
**Priming Chamber:** Gray Iron 30 Housing w/Stainless Steel Float and Linkage.  
**Discharge Check Valve:** Ductile Iron Housing w/Buna-N Flapper.  
**Radial Bearing:** Open Roller.  
**Thrust Bearing:** Open Double Ball.  
**Bearing Cavity Lubrication:** Lithium EP2 Grease.  
**Gaskets:** Vegetable Fiber, Compressed Synthetic Fibers and Buna-N.  
**O-Rings:** Buna-N.  
**Hardware:** Standard Plated Steel.  
**Seal Cavity Oil Level Gauges.**  
**Standard Equipment:** Gear-Driven Air Compressor. Hoisting Bail. Combination Skid Base w/Fuel Tank. [Single Ball Type Float Switch](#).\*\*  
*\*Consult Factory for Applications Exceeding Maximum Pressure and/or Temperature Indicated.*  
**Optional Equipment:** Battery. Strainer. Heated Priming Chamber Kit. High Speed (55 MPH/89 KM/H) Tandem Axle Pneumatic-Tired Wheel Kit w/wo DOT-Approved Lights and Electric Brakes. [Tandem Axle Over-the-Road Trailer](#). [Full Feature Control Panel](#) For Use w/Submersible Transducer Liquid Level Sensor (50 Ft. [15 M] Cable Standard, Alternate Lengths Available).  
**\*\*50 Ft. (15 m) Standard Length; Dual Switches and Alternate Cable Lengths Available From the Factory.**

**WARNING!**  
Do not use in explosive atmosphere or for pumping volatile flammable liquids.

**ENGINE SPECIFICATIONS**

**Model:** John Deere 6068HF285.  
**EPA Tier:** Tier 3.  
**Type:** Six Cylinder, Charge Air Cooled, Diesel Engine, w/Air Compressor, Enclosed.  
**Displacement:** 415 Cu. In. (6,8 liters).  
**Lubrication:** Forced Circulation.  
**Air Cleaner:** Dry Type.  
**Fuel Tank:** 130 U.S. Gals. (492 liters).  
**Full Load Operating Time:** 14.8 Hrs.  
**Starter:** 12V Electric.  
**Standard Features:** Muffler w/Weather Cap.  
**Optional:** Electronic Fuel Level Sensor.  
**Engine Control Features:** Padlockable Box with Throttle Control, Tachometer, Coolant Temperature, Oil Pressure, Voltage and Overstart Indicators/Shut-downs. Manual/Stop/Auto Keyswitch. Audible Startup Warning Delay. Fuel Level Display/Alarm/Shutdown (For Use With Optional Fuel Level Sensor).

**JOHN DEERE PUBLISHED PERFORMANCE:**  
 Maximum Gross BHP (Ind/Continuous)  
 173 (129 kW) @ 2400 RPM



GORMAN-RUPP PUMPS

www.grpumps.com

Specifications Subject to Change Without Notice

Printed in U.S.A.

**Specification Data**

APPROXIMATE  
DIMENSIONS and WEIGHTS

**NET WEIGHT:**  
**SHIPPING WEIGHT:**  
**EXPORT CRATE SIZE:**

**3800 LBS. [1724 KG.]**  
**5140 LBS. [2331 KG.]**  
**406 CU. FT. (11,5 CU. M.)**

SECTION 43, PAGE 217

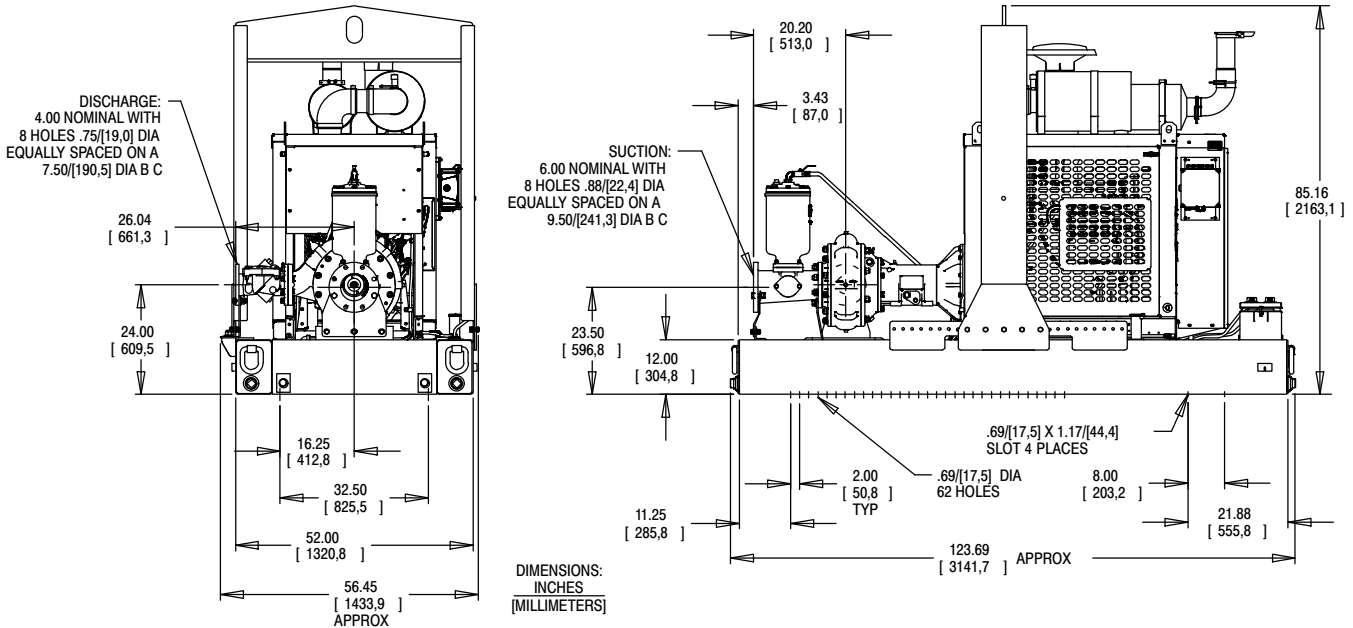

POWERED BY A JOHN DEERE 6068H TIER 3 DIESEL ENGINE

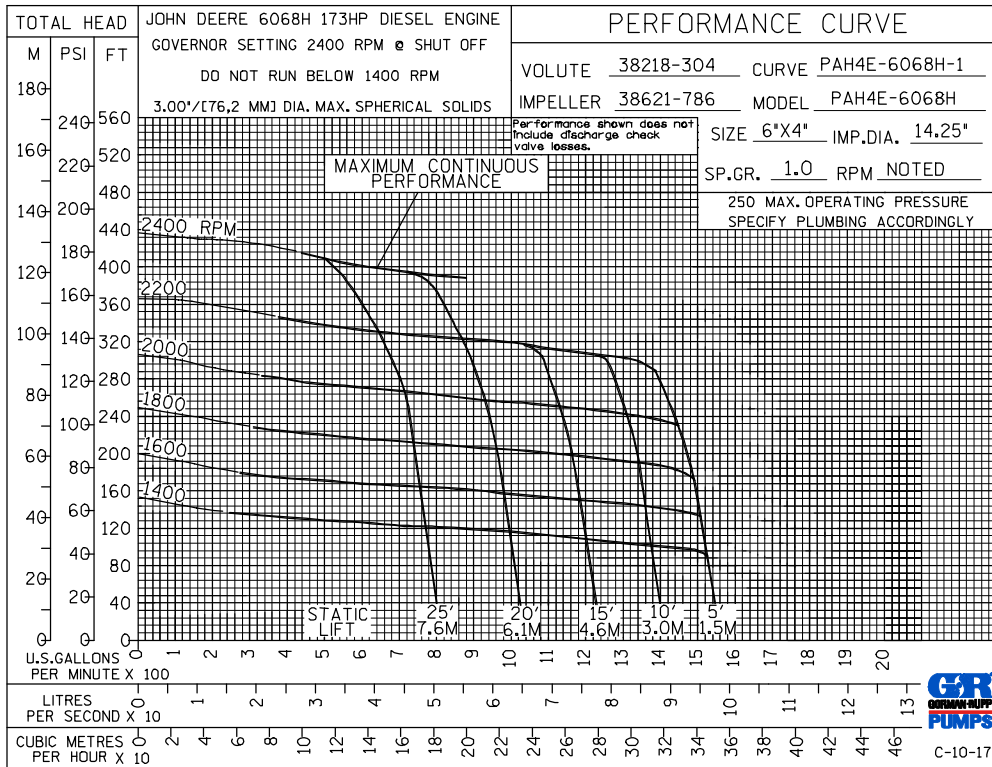

**GORMAN-RUPP PUMPS**

www.grpumps.com

Specifications Subject to Change Without Notice

Printed in U.S.A.