



VARIOUS PATENTS APPLY

Diesel Engine Driven Priming Assisted Centrifugal Pump w/Autostart Model PA6C60C-F4L Size 6" x 6"



Total Head		Capacity of Pump in U.S. Gallons per Minute (GPM) at Continuous Performance			
P.S.I.	Feet				
59.8	138	500	500	500	500
52.0	120	960	1060	1060	1060
43.3	100	1000	1460	1760	1760
34.7	80	1000	1480	1660	1920
26.0	60	1000	1480	1660	2020
17.3	40	1010	1480	1670	2020
8.7	20	1020	1480	1670	2020
Suction Lift		25'	20'	15'	10'



PUMP SPECIFICATIONS

- Size:** 6" x 6" (152 mm x 152 mm) Flanged.
- Casing:** Ductile Iron 65-45-12.
- Maximum Operating Pressure 99 psi (683 kPa).*
- Open Type, Two Vane Impeller:** Ductile Iron 65-45-12.
Handles 3" (76.2 mm) Diameter Spherical Solids.
- Impeller Shaft:** Stainless Steel 17-4 PH.
- Replaceable Wear Plate:** Ductile Iron 80-60-03.
- Removable Cleanout Cover Plate:** Gray Iron 30.
- Intermediate Bracket:** Gray Iron 30.
- Seal Plate:** Gray Iron 30.
- Seal:** Mechanical, Oil-Lubricated. Silicon Carbide Rotating and Stationary Faces. Stainless Steel 316 Stationary Seat. Fluorocarbon Elastomers (DuPont Viton® or Equivalent). Stainless Steel 18-8 Cage and Spring. Maximum Temperature of Liquid Pumped 160°F (71°C).*
- Shaft Sleeve:** Stainless Steel 17-4 PH.
- Priming Chamber:** Gray Iron 30.
- Discharge Check Valve:** Gray Iron 30 Housing w/Buna-N Flapper.
- Radial/Thrust Bearing:** Open Double Ball.
- Bearing and Seal Cavity Lubrication:** SAE 30 Non-Detergent Oil.
- Flanges:** Gray Iron 30.
- Gaskets:** Resistant Synthetic Rubber, Cork, PTFE, Vegetable Fiber, and Compressed Synthetic Fibers.
- Hardware:** Standard Plated Steel.
- Bearing and Seal Cavity Oil Level Sight Gauges.**

**Consult Factory for Applications Exceeding Maximum Pressure and/or Temperature Indicated.*

Standard Equipment: Hoisting Bail. Strainer. Belt-Driven Air Compressor. Combination Skid Base w/Fuel Tank. Single Ball Type Float Switch.**

****50 Ft. (15 m) Standard Length; Dual Switches and Alternate Cable Lengths Available From the Factory.**

Optional Equipment: Battery. High Speed (55 MPH/89 KM/H) Single Axle Pneumatic-Tired Wheel Kit w/wo DOT-Approved Lights and Electric Brakes. Tandem Axle Over-the-Road Trailer (Meets DOT Requirements) Available w/Either Electric or Hydraulic Surge Brakes, Running Lights, Jack Stands and Safety Cables/Chains. EPS w/Submersible Transducer Liquid Level Sensor (50 Ft. [15 M] Cable Standard, Alternate Lengths Available).

WARNING!

Do not use in explosive atmosphere or for pumping volatile flammable liquids.

ENGINE SPECIFICATIONS

- Model:** Deutz D914L4.
- Type:** Four Cylinder, Four Cycle, Air Cooled Diesel Engine.
- Displacement:** 263.2 Cu. In. (4,3 Liters).
- Governor:** Mechanical.
- Lubrication:** Forced Circulation.
- Air Cleaner:** Dry Element.
- Oil Reservoir:** 13.7 U.S. Qts. (13 Liters) Dry; 12.7 U.S. Qts. (12 Liters) Refill.
- Fuel Tank:** 88 U.S. Gallons (333 Liters).
- Full Load Operating Time:** 25.4 Hrs.
- Starter:** 12V Electric.
- Standard Features:** High Oil Temperature, Low Oil Pressure, V-belt, Alternator And Start Failure Safety Shut Down Switches/Indicators. Fuel Level Gauge. Throttle Control. Autostart Instrument Panel Includes: Temperature Gauge, Oil Pressure Gauge, Ammeter, Hourmeter, Tachometer, Manual/Stop/Auto Key Switch, 15 Amp Fuse, Audible Startup Warning Delay. Muffler w/Guard and Weather Cap.

DEUTZ PUBLISHED PERFORMANCE:
Maximum Gross Continuous B.H.P.
73.7 (55 kW) @ 2300 RPM



GORMAN-RUPP PUMPS

www.grpumps.com

Specifications Subject to Change Without Notice

Printed in U.S.A.

Specification Data

APPROXIMATE
DIMENSIONS and WEIGHTS

	SKID BASE	2-WHEEL
NET WEIGHT:	3040 LBS. (1379 KG.)	3330 LBS. (1511 KG.)
SHIPPING WEIGHT:	3190 LBS. (1447 KG.)	3330 LBS. (1511 KG.)
EXPORT CRATE SIZE:	233 CU. FT. (6,6 CU. M.)	

SECTION 42, PAGE 1122

SUCTION:
6.00 NOMINAL WITH 8 HOLES
TAPPED .750-10 UNC-2B X
.88/[22,4] DEEP, EQUALLY SPACED
ON A 9.50/[241,3] DIA. B.C.

DISCHARGE:
6.00 NOMINAL WITH 8 HOLES
.88/[22,4] DIA. EQUALLY SPACED
ON A 9.50/[241,3] DIA. B.C.

6.00 AISIBLIND FLANGE
(ALTERNATE SUCTION)

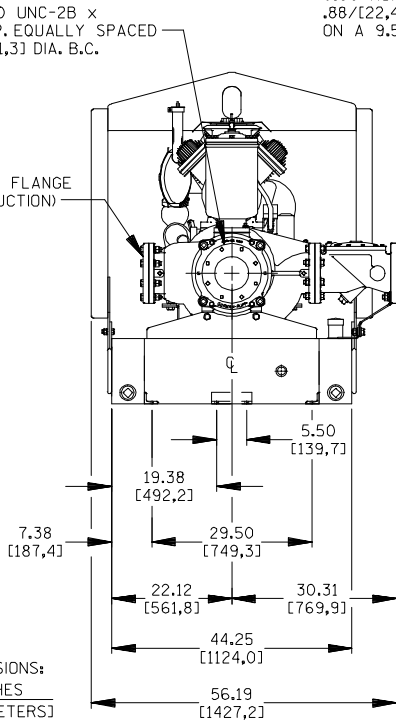

DIMENSIONS:
INCHES
[MILLIMETERS]

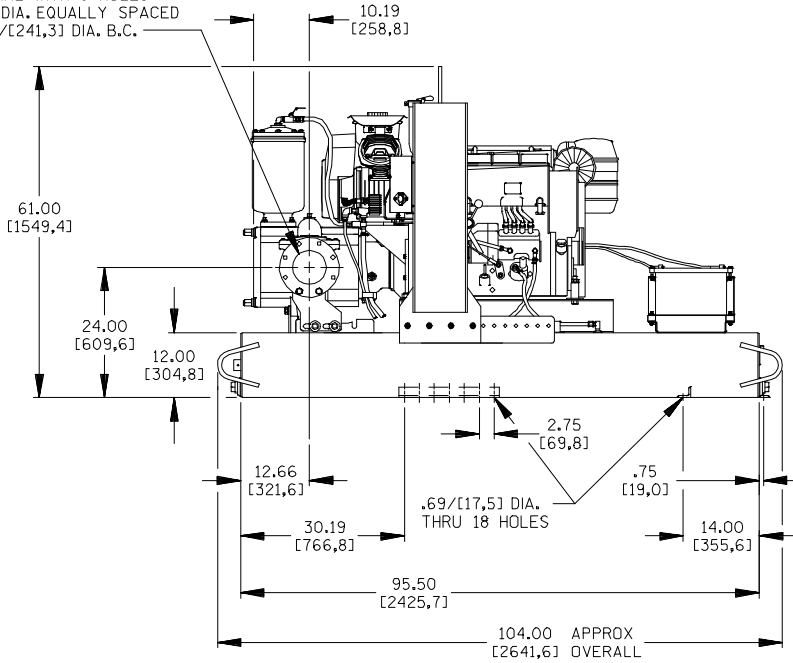

POWERED BY DEUTZ D914L4 DIESEL ENGINE

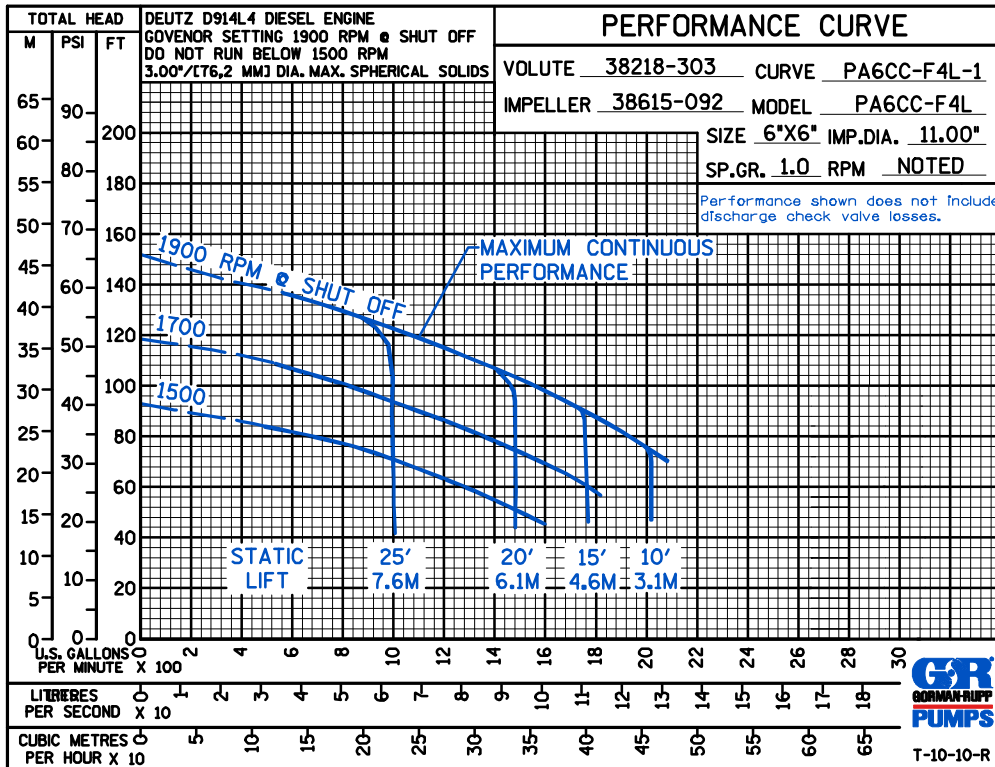

GORMAN-RUPP PUMPS

www.grpumps.com

Specifications Subject to Change Without Notice

Printed in U.S.A.