

# Priming Assisted Centrifugal Pump w/Autostart Model VPA4A60C-3CH1 FT4



Size 4" x 4"



Total Head		Capacity of Pump in U.S. Gallons per Minute (GPM) at Continuous Performance				
P.S.I.	Feet					
49.0	113	195	195	195	195	195
43.4	100	310	310	310	310	310
34.7	80	341	486	505	505	505
26.0	60	356	515	638	680	680
17.3	40	370	541	655	760	840
8.7	20	380	551	669	773	912
<b>Suction Lift</b>		<b>25'</b>	<b>20'</b>	<b>15'</b>	<b>10'</b>	<b>5'</b>



**PUMP SPECIFICATIONS**

- Size:** 4" x 4" (102 mm x 102 mm) Flanged.
- Casing:** Gray Iron 30.  
Maximum Operating Pressure 74 psi (510 kPa).  
Maximum Temperature of Liquid Pumped 160°F (71°C).\*
- Semi-Open Type, Single Vane Impeller:** Ductile Iron 65-45-12.  
Handles 3" (76,2 mm) Diameter Spherical Solids.
- Impeller Shaft:** Alloy Steel 4150.
- Replaceable Wear Plate:** Carbon Steel ASTM A36.
- Bearing Housing:** Gray Iron 30.
- Seal Plate:** Gray Iron 30.
- Seal:** Type 31, Mechanical, Oil-Lubricated. Silicon Carbide Rotating and Stationary Faces. Nitrile Elastomers. Stainless Steel 18-8 Cage and Spring.
- Shaft Sleeve:** Alloy Steel 4130.
- Priming Chamber:** Gray Iron 30 Housing w/Stainless Steel Float and Linkage.
- Discharge Check Valve:** Ductile Iron Housing with Welded Nickel Seat and Buna-N Flapper.
- Bearings:** Permanently Lubricated Single Row Ball.
- Seal Cavity Lubrication:** SAE 30 Non-Detergent Oil.
- Gaskets:** Red Rubber.
- O-Rings:** Buna-N.
- Hardware:** Standard Plated Steel.

*\*Consult Factory for Applications Exceeding Maximum Pressure and/or Temperature Indicated.*

**Standard Equipment:** Belt-Driven Air Compressor. Hoisting Bail. Combination Skid Base w/Fuel Tank. Strainer. Standard Auto-start Control Panel [Single Ball Type Float Switch](#).\*\*

**Optional Equipment:** Battery. Skid Drag Base Kit, High Speed (55 MPH/89 KM/H) Single Axle Pneumatic-Tired Wheel Kit w/ DOT-Approved Lights and Electric Brakes.

*\*\*50 Ft. (15 m) Standard Length; Dual Switches and Alternate Cable Lengths Available From the Factory.*

WARNING!

Do not use in explosive atmosphere or for pumping volatile flammable liquids.

**ENGINE SPECIFICATIONS**

- Model:** Isuzu 3CH1.
- EPA Tier:** Final Tier 4.
- Type:** Three Cylinder, Diesel Engine.
- Displacement:** 97.6 Cu. In. (1,6 Liters).
- Lubrication:** Forced Circulation.
- Governor:** Mechanical.
- Air Cleaner:** Dry Type.
- Fuel Tank:** 34 U.S. Gals. (128,7 Liters).
- Full Load Operating Time:** 21.9 Hrs.
- Starter:** 12V Electric.
- Standard Features:** Muffler w/Weather Cap. DOC Exhaust After-Treatment System.
- Optional:** Electronic Fuel Level Sensor.
- Engine Control Features:** Padlockable Box, Tachometer, Coolant Temperature, Oil Pressure, Voltage and Overstart Indicators/Shutdowns. Manual/Stop/Auto Keyswitch. Audible Startup Warning Delay. Fuel Level Display/Alarm/Shutdown (For Use With Optional Fuel Level Sensor).

**ISUZU PUBLISHED PERFORMANCE:**

Maximum Gross Continuous BHP  
23.9 (17.8 kW) @ 3000 RPM



GORMAN-RUPP PUMPS

www.grpumps.com

Specifications Subject to Change Without Notice

Printed in U.S.A.

**Specification Data**

SECTION 41, PAGE 100

APPROXIMATE DIMENSIONS and WEIGHTS

**SKID BASE**

**NET WEIGHT:** 1335 LBS. (605,5 KG.)  
**SHIPPING WEIGHT:** 1335 LBS. (605,5 KG.)  
**EXPORT CRATE SIZE:** 133.6 CU. FT. (3,8 CU. M.)

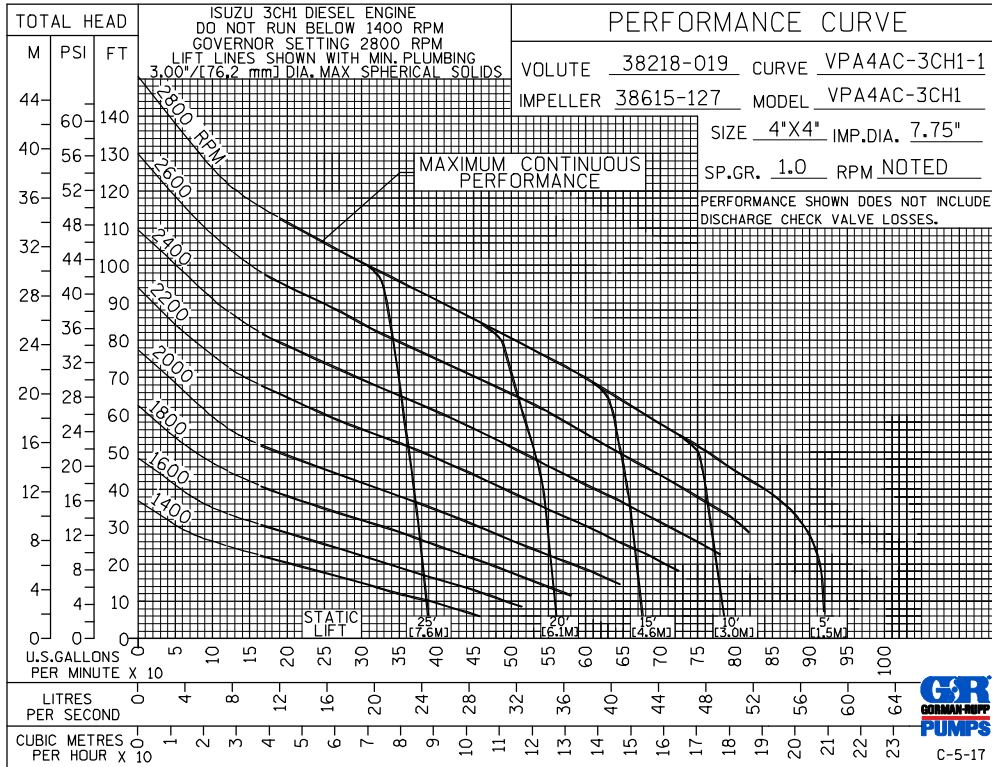
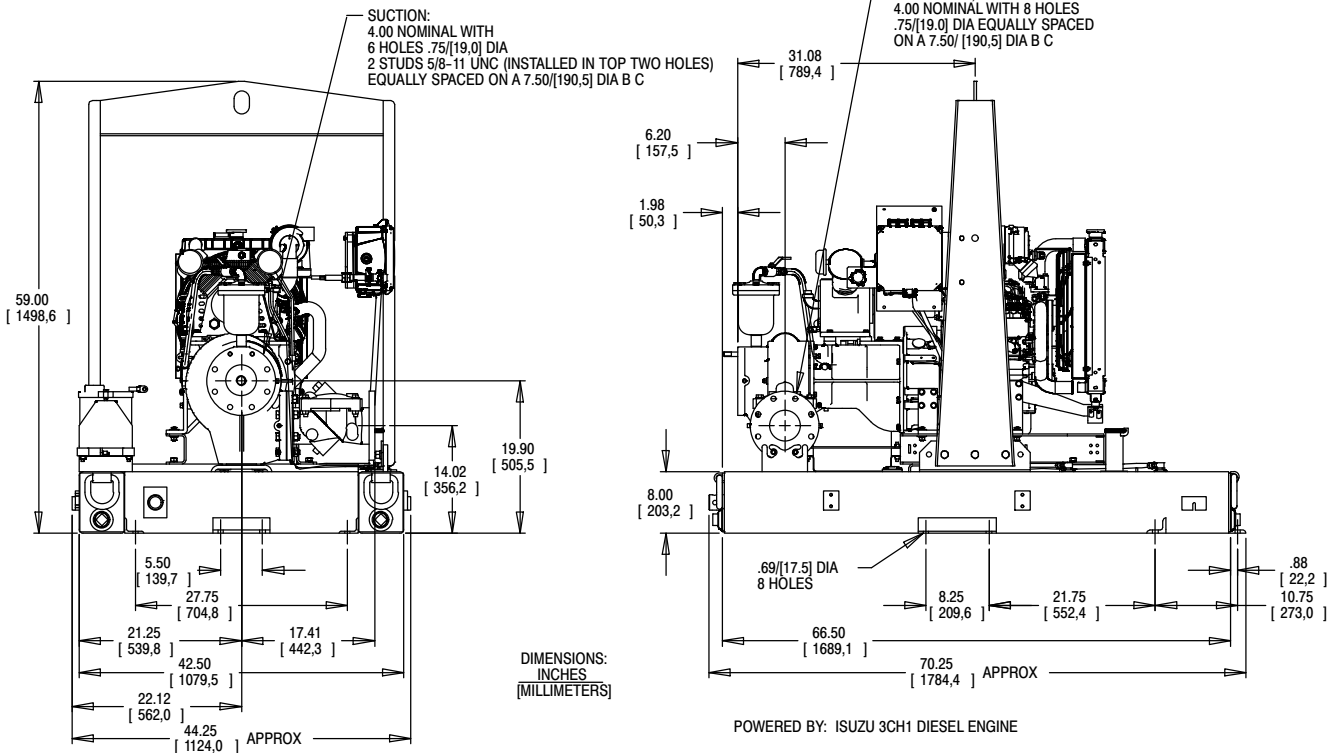

**GORMAN-RUPP PUMPS**

www.grpumps.com

Specifications Subject to Change Without Notice

Printed in U.S.A.