



# Self Priming Centrifugal Pump

## Model 810A2-F5L

### Size 10" x 10"



Total Head		Capacity of Pump in U.S. Gallons per Minute (GPM) at Continuous Performance		
P.S.I.	Feet			
58.5	135	600	600	600
52.0	120	1040	1040	1040
43.4	100	1720	1720	1720
34.7	80	2040	2240	2320
26.0	60	2140	2380	2620
17.3	40	2230	2530	2740
8.7	20	2300	2650	2840
<b>Suction Lift</b>		<b>20'</b>	<b>15'</b>	<b>10'</b>



#### PUMP SPECIFICATIONS

**Size:** 10" x 10" (254 mm x 254 mm) NPT - Female.

**Casing:** Gray Iron 30.

Maximum Operating Pressure 99 psi (683 kPa).\*

**Semi-Open Type, Two Vane Impeller:** Ductile Iron 65-45-12.

Handles 2 1/2" (63,5 mm) Diameter Spherical Solids.

**Impeller Shaft:** Alloy Steel 4150.

**Replaceable Wear Plate:** Gray Iron 30.

**Intermediate Bracket:** Gray Iron 30.

**Seal Plate:** Gray Iron 30.

**Seal:** Double, Grease-Lubricated w/Spring-Loaded Grease Cup. Sintered Bronze Stationary Seal Seats. Steel Rotating Faces. Neoprene Packing Rings. Maximum Temperature of Liquid Pumped 110°F (43°C). Maximum Suction Pressure 10 psi (69 kPa).\*

**Seal Liner:** Copper Alloy C93700.

**Flap Valve:** Neoprene w/Fabric Reinforcing, Gray Iron 30 and Ductile Iron 65-45-12.

**Radial Bearing:** Open Double Row Ball.

**Thrust Bearing:** Open Single Row Ball.

**Bearing Lubrication:** SAE 30 Non-Detergent Oil.

**Flanges:** Gray Iron 30.

**Gaskets:** Vegetable Fiber.

**O-Rings:** Buna-N.

**Hardware:** Standard Plated Steel.

**Standard Equipment:** Oil Level Sight Gauge, Hoisting Bail, Skid Base, Strainer and 90° Discharge Elbow.

**Optional Equipment:** Battery. High Speed (55 MPH/89 KM/H) Single Axle Pneumatic-Tired Wheel Kit. [Tandem Axle Over-the-Road Trailer](#).

\*Consult Factory for Applications Exceeding Maximum Pressure and/or Temperature Indicated.



#### ENGINE SPECIFICATIONS

**Model:** Deutz D914L5.

**EPA Tier:** Tier 3.

**Type:** Five Cylinder, Four Cycle, Air Cooled Diesel Engine.

**Displacement:** 329 Cu. In. (5,4 Liters).

**Lubrication:** Forced Circulation.

**Air Cleaner:** Oil Bath.

**Fuel Tank:** 38.9 U.S. Gals. (147,3 Liters).

**Full Load Operating Time:** 11.3 Hrs.

**Starter:** 12V Electric.

**Standard Features:** High Oil Temperature, Low Oil Pressure, V-belt, Alternator and Start Failure Safety Shut Down Switches/Indicators. Fuel Level Gauge. Throttle Control. Instrument Panel Includes: Temperature Gauge, Oil Pressure Gauge, Ammeter, Hourmeter, Tachometer, Start/Stop Key Switch, 15 Amp Fuse. Muffler w/Guard and Weather Cap.

#### DEUTZ PUBLISHED PERFORMANCE:

Maximum Gross Continuous B.H.P.

91.8 (68.5 kW) @ 2300 RPM



## GORMAN-RUPP PUMPS

www.grpumps.com

Specifications Subject to Change Without Notice

Printed in U.S.A.

**Specification Data**

SECTION 40, PAGE 2700

APPROXIMATE DIMENSIONS and WEIGHTS

	<b>SKID BASE</b>	<b>2-WHEEL</b>
<b>NET WEIGHT:</b>	2750 LBS. (1247 KG.)	3150 LBS. (1429 KG.)
<b>SHIPPING WEIGHT:</b>	2822 LBS. (1280 KG.)	3150 LBS. (1429 KG.)
<b>EXPORT CRATE SIZE:</b>	171.2 CU. FT. (4,85 CU. M.)	

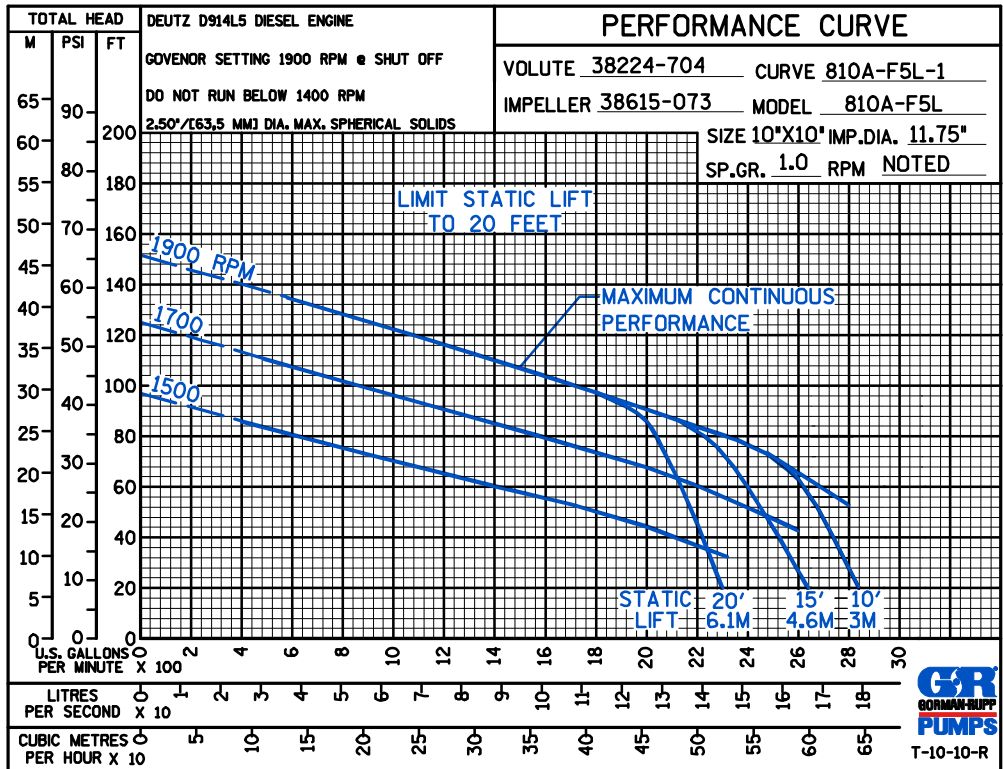
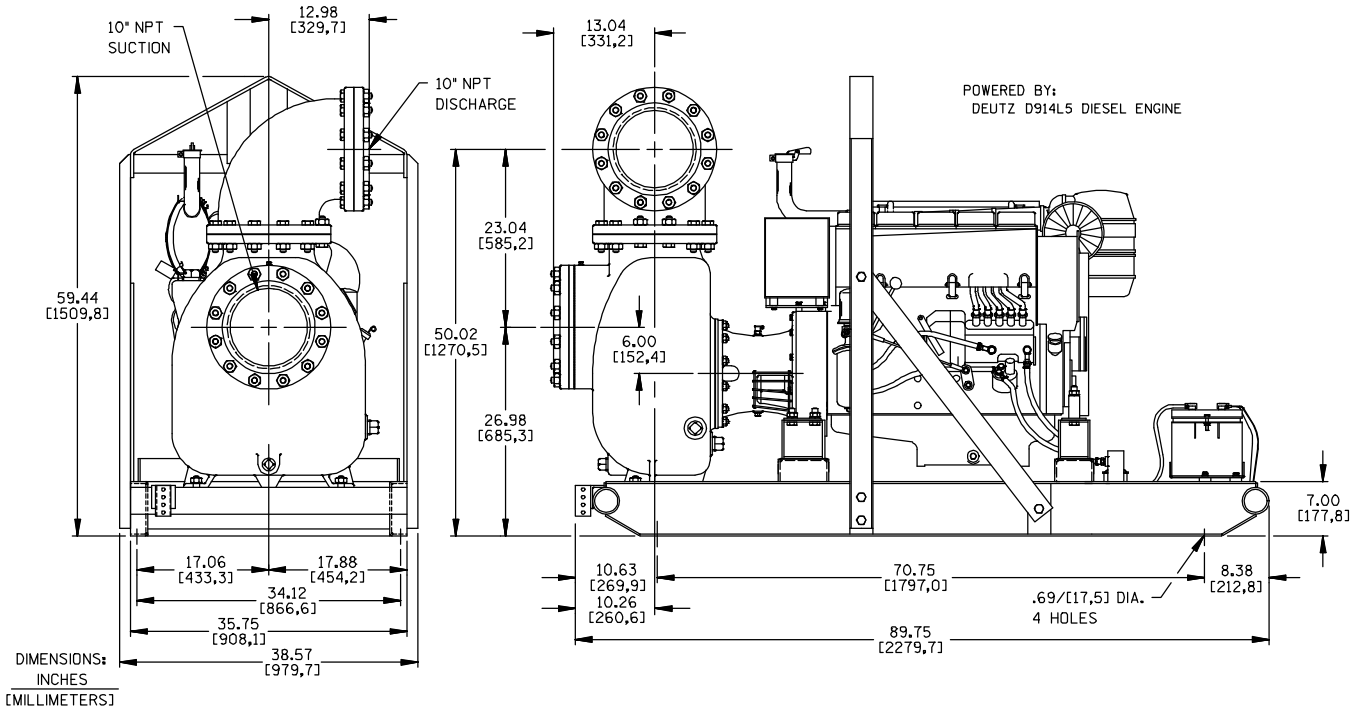

**GORMAN-RUPP PUMPS**

www.grpumps.com

Specifications Subject to Change Without Notice

Printed in U.S.A.