



# Self Priming Centrifugal Pump

## Model 88B2-F5L

### Size 8" x 8"



Total Head		Capacity Of Pump In U.S. Gallons Per Minute (GPM) At Continuous Performance				
P.S.I.	Feet					
64.2	148	N/A	640	640	640	640
60.7	140	N/A	800	880	880	880
52.0	120	720	1060	1430	1500	1500
43.4	100	840	1230	1610	1820	1900
34.7	80	960	1340	1710	2010	2160
26.0	60	1060	1430	1800	2110	2280
17.3	40	1150	1510	1880	2180	2370
8.7	20	1240	1560	1960	2240	2420
<b>Suction Lift</b>		<b>25'</b>	<b>20'</b>	<b>15'</b>	<b>10'</b>	<b>5'</b>



#### PUMP SPECIFICATIONS

**Size:** 8" x 8" (204 mm x 204 mm) NPT - Female.

**Casing:** Gray Iron 30.

Maximum Operating Pressure 111 psi. (765 kPa).\*

**Semi-Open Type, Three Vane Impeller:** Gray Iron 30.

Handles 2 3/8" (60,3 mm) Diameter Spherical Solids.

**Impeller Shaft:** Carbon Steel 4150.

**Replaceable Wear Plate:** Gray Iron 30.

**Intermediate Bracket:** Gray Iron 30.

**Seal Plate:** Gray Iron 30.

**Seal:** Double, Grease-Lubricated with Spring-Loaded Grease Cup. Sintered Bronze Stationary Seal Seats. Steel Rotating Faces. Neoprene Packing Rings. Maximum Temperature of Liquid Pumped 110°F (43°C). Maximum Suction Pressure 10 psi (69 kPa).\*

**Seal Liner:** Copper Alloy C26000.

**Flap Valve:** Buna-N <sup>w</sup>/Nylon Reinforcement and Steel.

**Radial/Thrust Bearings:** Tapered Roller Type.

**Bearing Lubrication:** Grease.

**Flanges:** Gray Iron 30.

**Gaskets:** Vegetable Fiber.

**Hardware:** Standard Plated Steel.

**Standard Equipment:** Hoisting Bail. Skid Base. 90° Discharge Elbow. Strainer.

**Optional Equipment:** Battery. High Speed (55 MPH/89 KM/H) Tandem Axle Pneumatic-Tired Wheel Kit. [Tandem Axle Over-the-Road Trailer](#).

\*Consult Factory for Applications Exceeding Maximum Pressure and/or Temperature Indicated.



#### WARNING!

Do not use in explosive atmosphere or for pumping volatile flammable liquids.

#### ENGINE SPECIFICATIONS

**Model:** Deutz D914L5.

**EPA Tier:** Tier 3.

**Type:** Five Cylinder, Four Cycle, Air Cooled Diesel Engine.

**Displacement:** 329 Cu. In. (5,4 Liters).

**Lubrication:** Forced Circulation.

**Air Cleaner:** Oil Bath.

**Fuel Tank:** 38.9 U.S. Gallons (147,3 Liters)

**Full Load Operating Time:** 10.4 Hrs.

**Starter:** 12V Electric.

**Standard Features:** High Oil Temperature, Low Oil Pressure, V-belt, Alternator and Start Failure Safety Shut Down Switches/Indicators. Fuel Level Gauge. Throttle Control. Instrument Panel Includes: Temperature Gauge, Oil Pressure Gauge, Ammeter, Hourmeter, Tachometer, Start/Stop Key Switch, 15 Amp Fuse. Muffler <sup>w</sup>/Guard and Weather Cap.

#### DEUTZ PUBLISHED PERFORMANCE:

Maximum Gross Continuous B.H.P.  
91.8 (68.5 kW) @ 2300 RPM



## GORMAN-RUPP PUMPS

www.grpumps.com

Specifications Subject to Change Without Notice

Printed in U.S.A.

# Specification Data

SECTION 40, PAGE 2590

APPROXIMATE DIMENSIONS and WEIGHTS

	SKID BASE	2-WHEEL
NET WEIGHT:	2424 LBS. [1099,5 KG.]	2949 LBS. [1337,6 KG.]
SHIPPING WEIGHTS:	2549 LBS. [1156,2 KG.]	2949 LBS. [1337,6 KG.]
EXPORT CRATE:	139 CU. FT. [3.9 CU. M.]	

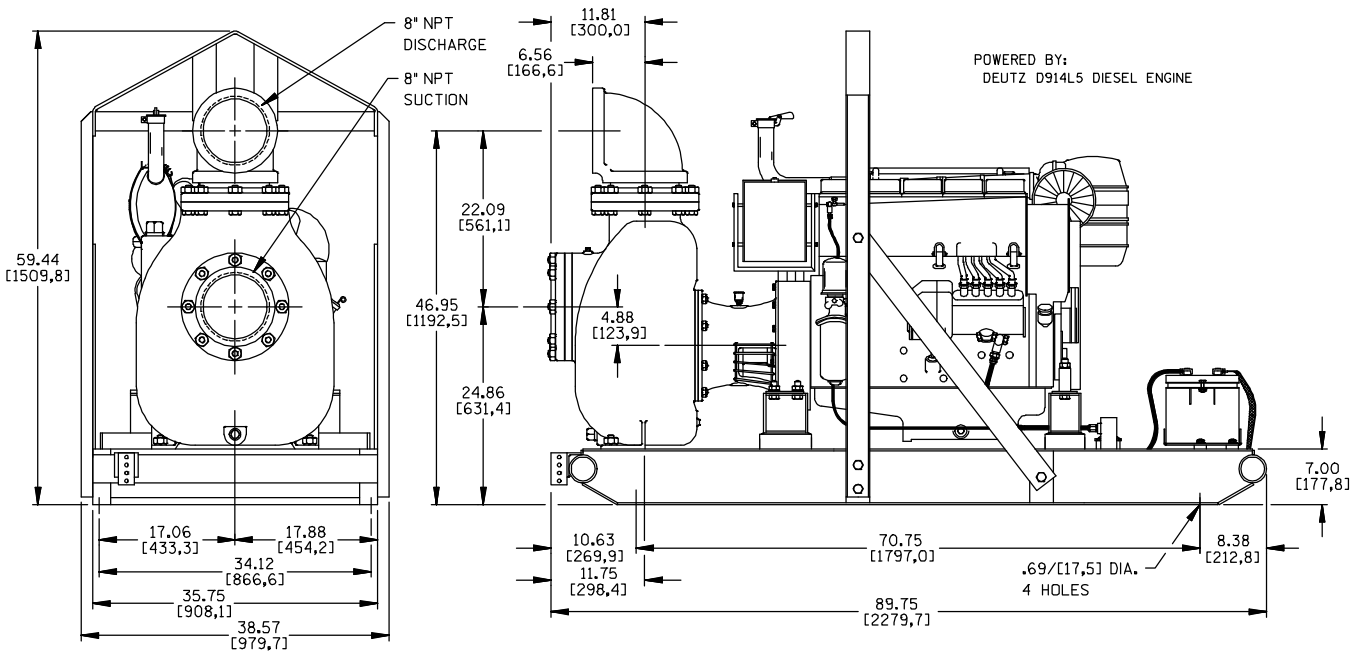

DIMENSIONS:  
INCHES  
[MILLIMETERS]

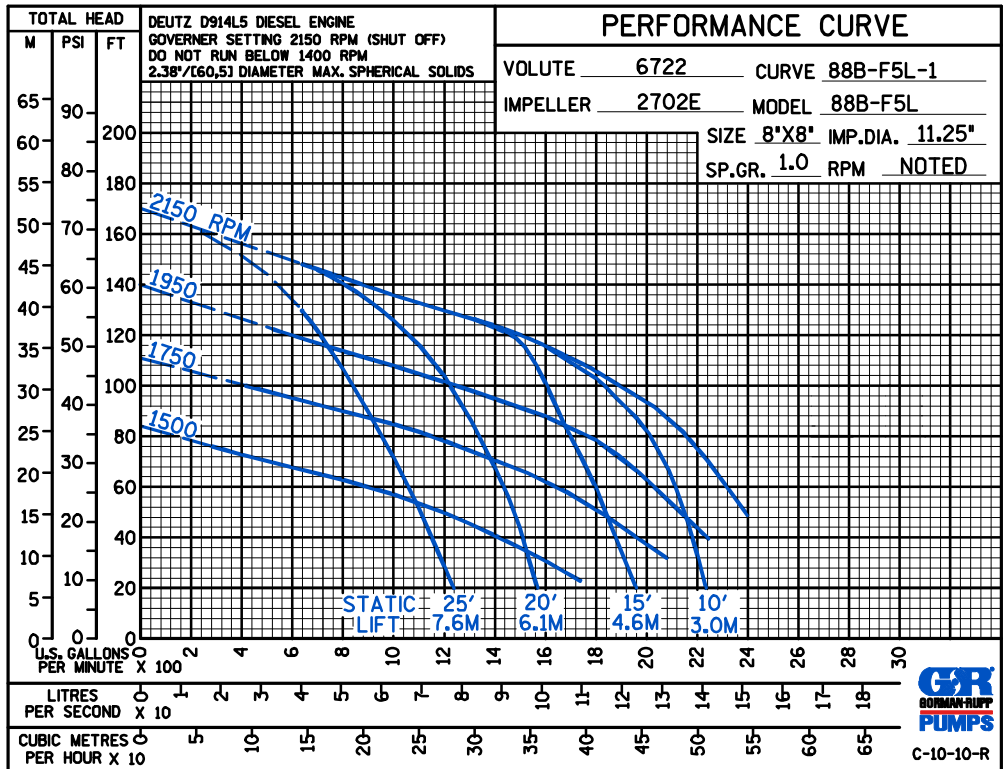

## GORMAN-RUPP PUMPS

www.grpumps.com

Specifications Subject to Change Without Notice

Printed in U.S.A.