

# Self Priming Centrifugal Pump



## Model 86A2-F4L

Size 6" x 6"



Total Head		Capacity Of Pump In U.S. Gallons Per Minute (GPM) At Continuous Performance				
P.S.I.	Feet					
70.2	162	360	360	360	360	360
69.4	160	435	435	435	435	435
60.7	140	755	980	990	1000	1000
52.0	120	800	1115	1260	1320	1320
43.4	100	820	1145	1410	1540	1530
34.7	80	825	1165	1430	1640	1700
26.0	60	838	1180	1440	1660	1810
17.3	40	840	1185	1450	1665	1885
8.7	20	840	1190	1460	1670	1920
<b>Suction Lift</b>		<b>25'</b>	<b>20'</b>	<b>15'</b>	<b>10'</b>	<b>5'</b>



### PUMP SPECIFICATIONS

**Size:** 6" x 6" (152 mm x 152 mm) NPT - Female.

**Casing:** Gray Iron 30.

Maximum Operating Pressure 114 psi (786 kPa).\*

**Semi-Open Type, Three Vane Impeller:** Gray Iron 30.  
Handles 1 15/16" (49,3 mm) Diameter Spherical Solids.

**Impeller Shaft:** Carbon Steel 4150.

**Replaceable Wear Plate:** Gray Iron 30.

**Intermediate Bracket:** Gray Iron 30.

**Seal Plate:** Gray Iron 30.

**Seal:** Double, Grease-Lubricated w/Spring-Loaded Grease Cup. Sintered Bronze Stationary Seal Seats. Steel Rotating Faces. Neoprene Packing Rings. Maximum Temperature of Liquid Pumped, 110 F (43 C).\* Maximum Suction Pressure 10 psi (69 kPa).\*

**Seal Liner:** Copper Alloy C26000.

**Flap Valve:** Buna-N w/Nylon Reinforcement and Steel.

**Radial and Thrust Bearings:** Tapered Roller Type.

**Bearing Lubrication:** Grease.

**Flanges:** Gray Iron 30.

**Gaskets:** Vegetable Fiber.

**Hardware:** Standard Plated Steel.

**Standard Equipment:** Hoisting Bail. Skid Base. 90° Discharge Elbow. Strainer.

**Optional Equipment:** Battery. Single Axle Pneumatic-Tired Wheel Kit. [Tandem Axle Over-the-Road Trailer](#).

\*Consult Factory for Applications Exceeding Maximum Pressure and/or Temperature Indicated.



### ENGINE SPECIFICATIONS

**Model:** Deutz D914L4.

**EPA Tier:** Interim Tier 4.

**Type:** Four Cylinder, Four Cycle, Air Cooled Diesel Engine.

**Displacement:** 263.2 Cu. In. (4,3 Liters).

**Lubrication:** Forced Circulation.

**Air Cleaner:** Dry Element.

**Fuel Tank:** 38.9 U.S. Gallons (147,3 Liters).

**Full Load Operating Time:** 12.4 Hrs.

**Starter:** 12V Electric.

**Standard Features:** High Oil Temperature, Low Oil Pressure, V-belt, Alternator And Start Failure Safety Shut Down Switches/Indicators. Fuel Level Gauge. Throttle Control. Instrument Panel with: Temperature Gauge, Oil Pressure Gauge, Ammeter, Hourmeter, Tachometer, Start/Stop Key Switch, 15 Amp Fuse. Muffler w/Guard and Weather Cap.

### DEUTZ PUBLISHED PERFORMANCE:

Maximum Gross Continuous B.H.P.  
73.7 (55 kW) @ 2300 RPM



GORMAN-RUPP PUMPS

www.grpumps.com

Specifications Subject to Change Without Notice

Printed in U.S.A.

**Specification Data**

SECTION 40, PAGE 1870

APPROXIMATE  
DIMENSIONS and  
WEIGHTS

**SKID BASE**

NET WEIGHT: 1960 LBS. [889,0 KG.]  
SHIPPING WEIGHTS: 2256 LBS. [1023,3 KG.]  
EXPORT CRATE: 175.6 CU. FT. [5 CU. M.]

**2-WHEEL**

2586 LBS. [1173,0 KG.]  
2586 LBS. [1173,0 KG.]

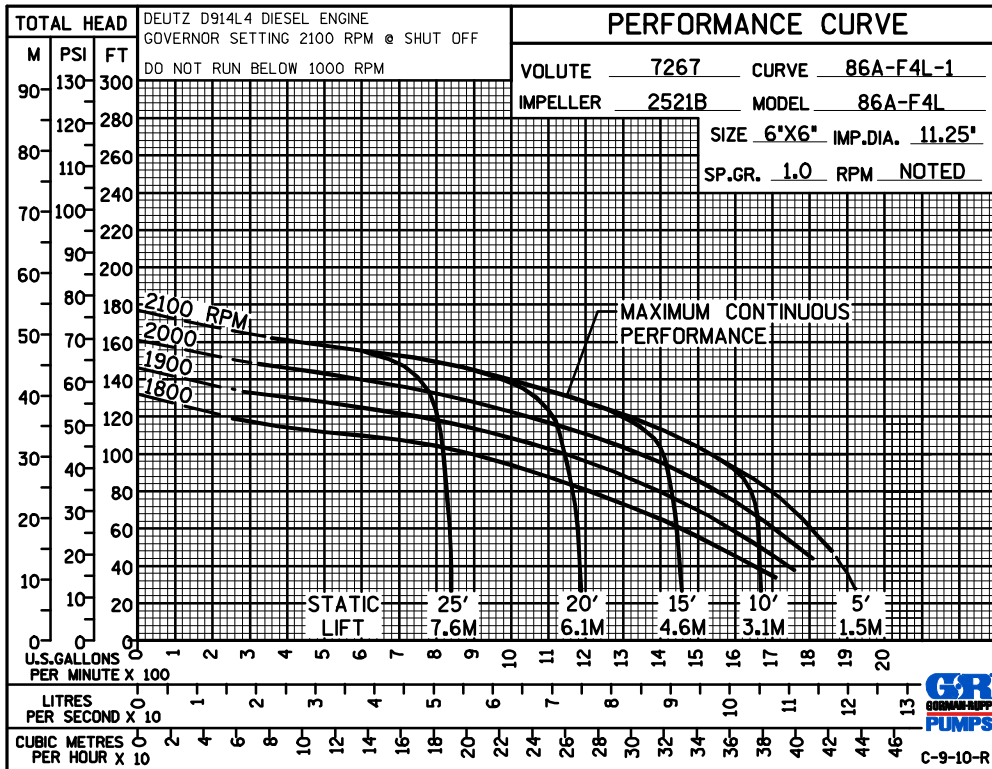
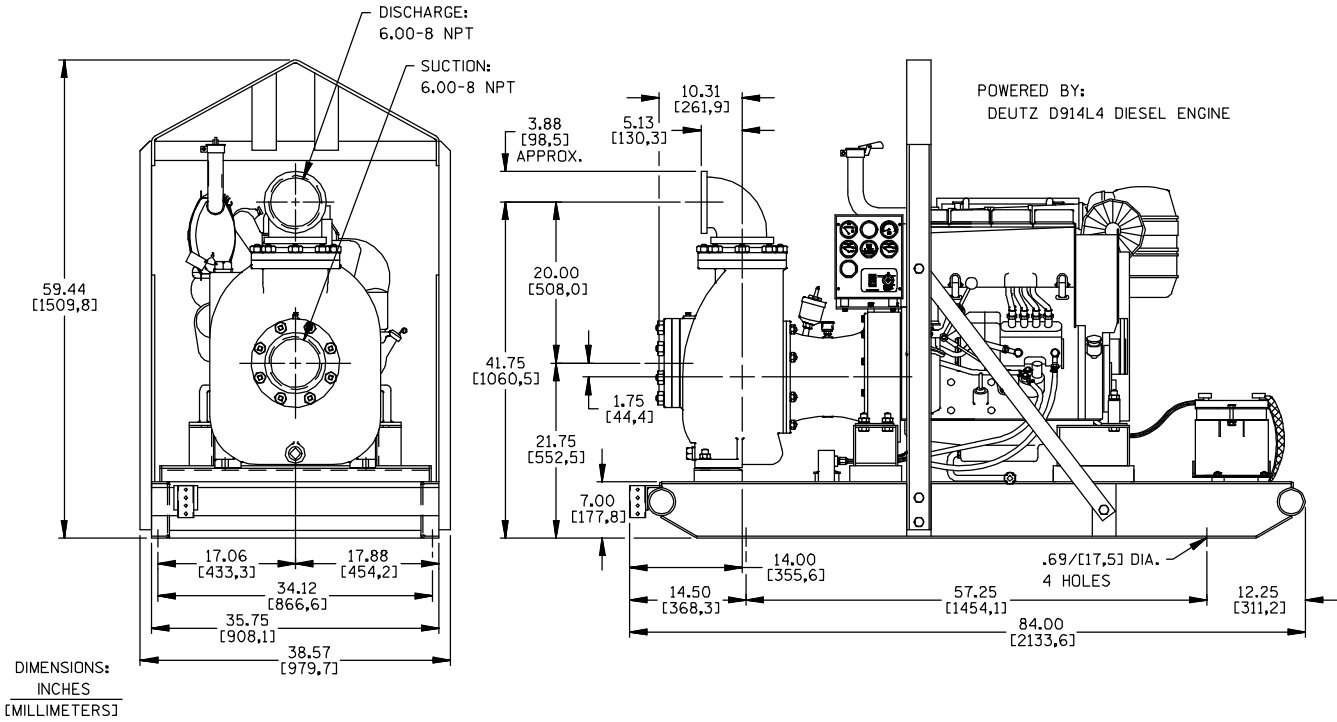

**GORMAN-RUPP PUMPS**

www.grpumps.com

Specifications Subject to Change Without Notice

Printed in U.S.A.