



# Self Priming Centrifugal Pump

## Model 03H1-GX390

### Size 3" x 3"



Total Head		Capacity of Pump in U.S. Gallons per Minute (GPM) at Continuous Performance			
P.S.I.	Feet				
69.4	160	70	70	70	70
60.7	140	155	155	155	155
52.0	120	156	221	221	221
43.4	100	157	222	290	290
34.7	80	158	223	295	356
26.0	60	158	224	296	359
17.3	40	158	225	299	360
<b>Suction Lift</b>		<b>25'</b>	<b>20'</b>	<b>15'</b>	<b>10'</b>



#### PUMP SPECIFICATIONS

**Size:** 3" x 3" (76 mm x 76 mm) NPT – Female.

**Casing:** Aluminum 356-T6.

Maximum Operating Pressure 103 psi (710 kPa).\*

**Enclosed Type, Five Vane Impeller:** Aluminum Alloy ASTM B26. Handles 7/16" (11,1 mm) Diameter Spherical Solids.

**Intermediate:** Aluminum 356-T6.

**Replaceable Wear Rings:** Copper Alloy C93200.

**Shaft Sleeve:** Alloy Steel 4130.

**Seal:** Type 2, Mechanical, Self-Lubricated. Carbon Rotating Face. Ni-Resist Stationary Face. Fluorocarbon Elastomers (DuPont Viton® or Equivalent). Stainless Steel 18-8 Cage and Spring. Maximum Temperature of Liquid Pumped, 160°F (71°C).\*

**Suction Flange:** Aluminum 356-T6.

**Gaskets:** Cork.

**Hardware:** Standard Plated Steel.

**Standard Equipment:** 90° Discharge Elbow.  
Rollover Base with Rubber Feet.

**Optional Equipment:** Wheel Kit w/Semi-Pneumatic Tires.  
Victaulic® Suction and Discharge Flanges. Horizontal  
Victaulic® Suction and Discharge Flanges w/Discharge  
Elbow.

Victaulic® is a Registered Trademark of Victaulic Company of America.

*\*Consult Factory for Applications Exceeding  
Maximum Pressure and/or Temperature Indicated.*



**Model:** Honda GX390.

**Type:** Single Cylinder, Air Cooled,  
Overhead Valve, Gasoline Engine.

**Displacement:** 23.7 Cu. In. (389 cc).

**Cylinder:** Aluminum Alloy.

**Air Cleaner:** Dual Element.

**Fuel Tank:** 6.9 U.S. Qts. (6,5 liter).

**Full Load Operating Time:** 1.2 Hrs.

**Starter:** Recoil.

**Ignition System:** Transistorized Magneto.

**Standard Equipment:** Muffler w/Guard. Rotary  
Stop Switch. Manual Throttle Control w/Top  
Speed Limit. Manual Choke and Fuel Valve.  
Oil Alert™ Shut Down. Fill/Drain Ports Each  
Side w/Dipstick One Side Only. Spark Plug  
Cover.



## GORMAN-RUPP PUMPS

www.grpumps.com

Specifications Subject to Change Without Notice

Printed in U.S.A.

# Specification Data

APPROXIMATE DIMENSIONS and WEIGHTS

NET WEIGHT: 144 LBS. (65,3 KG.)  
 SHIPPING WEIGHT: 220 LBS. (99,8 KG.)  
 EXPORT CRATE SIZE: 16.8 CU. FT. (0,48 CU. M.)  
 WHEEL KIT ADD 25 LBS. (11,3 KG.); SHIPPING CRATE (SEPARATE) 3 CU. FT. (0,1 CU. M.)

SECTION 20, PAGE 330

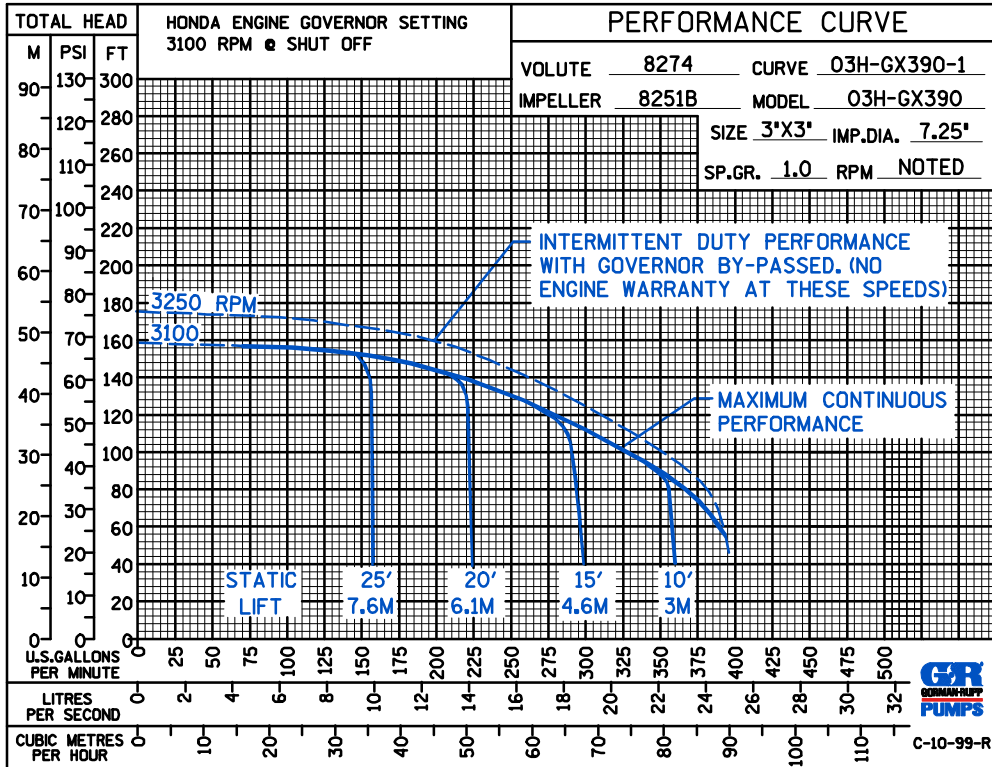
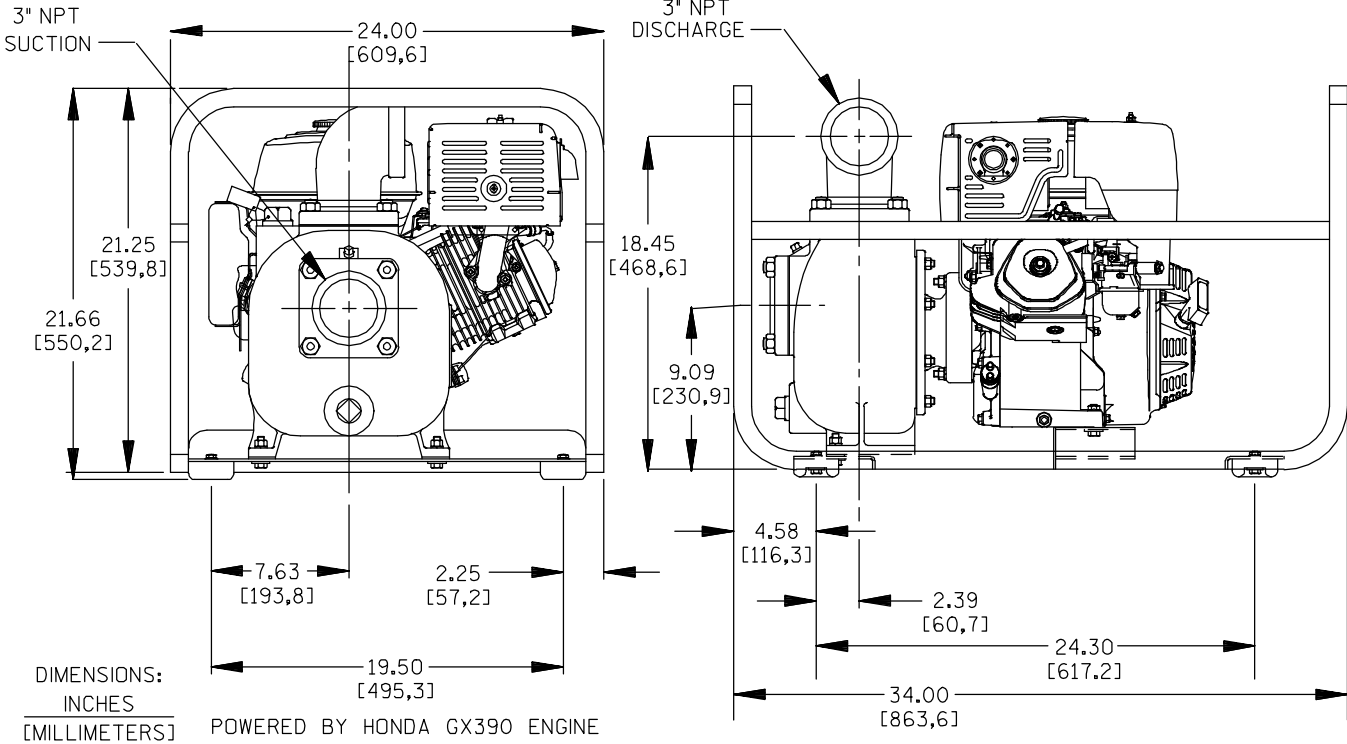

GORMAN-RUPP PUMPS

www.grpumps.com

Specifications Subject to Change Without Notice

Printed in U.S.A.