

**INSTALLATION, OPERATION,
AND MAINTENANCE MANUAL**
WITH PARTS LIST



6400 SERIES® PUMP

MODEL
6403C60-B

GORMAN-RUPP PUMPS

www.grpumps.com

Register your new
Gorman-Rupp pump online at
www.grpumps.com

Valid serial number and e-mail address required.

RECORD YOUR PUMP MODEL AND SERIAL NUMBER

Please record your pump model and serial number in the spaces provided below. Your Gorman-Rupp distributor needs this information when you require parts or service.

Pump Model: _____

Serial Number: _____

TABLE OF CONTENTS

INTRODUCTION	PAGE I – 1
SAFETY - SECTION A	PAGE A – 1
INSTALLATION – SECTION B	PAGE B – 1
PREINSTALLATION INSPECTION	PAGE B – 1
POSITIONING PUMP	PAGE B – 2
Lifting	PAGE B – 2
Mounting	PAGE B – 2
SUCTION AND DISCHARGE PIPING	PAGE B – 2
Materials	PAGE B – 2
Line Configuration	PAGE B – 2
Connections to Pump	PAGE B – 3
Gauges	PAGE B – 3
SUCTION LINES	PAGE B – 3
Fittings	PAGE B – 3
Strainers	PAGE B – 3
Sealing	PAGE B – 3
DISCHARGE LINES	PAGE B – 3
Siphoning	PAGE B – 3
Valves	PAGE B – 3
ALIGNMENT	PAGE B – 3
Coupled Drives	PAGE B – 4
Drive Belts	PAGE B – 4
OPERATION – SECTION C	PAGE C – 1
STARTING	PAGE C – 1
OPERATION	PAGE C – 1
Leakage	PAGE C – 1
Liquid Temperature And Overheating	PAGE C – 1
Strainer Check	PAGE C – 1
STOPPING	PAGE C – 1
Cold Weather Preservation	PAGE C – 2
BEARING TEMPERATURE CHECK	PAGE C – 2

TABLE OF CONTENTS
(continued)

TROUBLESHOOTING – SECTION D	PAGE D – 1
PREVENTIVE MAINTENANCE	PAGE D – 3
PUMP MAINTENANCE AND REPAIR - SECTION E	PAGE E – 1
STANDARD PERFORMANCE CURVE	PAGE E – 1
PARTS LIST:	
Pump End Assembly	PAGE E – 3
Repair Rotating Assembly	PAGE E – 5
PUMP AND SEAL DISASSEMBLY AND REASSEMBLY	PAGE E – 6
Rotating Assembly Removal	PAGE E – 7
Draining Oil From Seal Cavity	PAGE E – 7
Impeller Removal	PAGE E – 7
Seal Removal	PAGE E – 8
Shaft and Bearing Removal And Disassembly	PAGE E – 8
Shaft and Bearing Reassembly and Installation	PAGE E – 9
Seal Installation	PAGE E – 10
Impeller Installation	PAGE E – 13
Rotating Assembly Installation	PAGE E – 13
Final Pump Assembly	PAGE E – 13
LUBRICATION	PAGE E – 13
Seal Assembly	PAGE E – 13
Bearings	PAGE E – 14

INTRODUCTION

Thank You for purchasing a Gorman-Rupp pump. **Read this manual** carefully to learn how to safely install and operate your pump. Failure to do so could result in personal injury or damage to the pump.

Because pump installations are seldom identical, this manual cannot possibly provide detailed instructions and precautions for every aspect of each specific application. Therefore, it is the responsibility of the owner/installer of the pump to ensure that applications not addressed in this manual are performed **only** after establishing that neither operator safety nor pump integrity are compromised by the installation. Pumps and related equipment **must** be installed and operated according to all national, local and industry standards.

If there are any questions regarding the pump or its application which are not covered in this manual or in other literature accompanying this unit, please contact your Gorman-Rupp distributor, or The Gorman-Rupp Company:

The Gorman-Rupp Company
P.O. Box 1217
Mansfield, Ohio 44901—1217
Phone: (419) 755—1011
 or:
Gorman-Rupp of Canada Limited
70 Burwell Road
St. Thomas, Ontario N5P 3R7
Phone: (519) 631—2870

For information or technical assistance on the power source, contact the power source manufacturer's local dealer or representative.

HAZARD AND INSTRUCTION DEFINITIONS

The following are used to alert maintenance personnel to procedures which require special attention, to those which could damage equipment, and to those which could be dangerous to personnel:



Immediate hazards which WILL result in severe personal injury or death. These instructions describe the procedure required and the injury which will result from failure to follow the procedure.



Hazards or unsafe practices which COULD result in severe personal injury or death. These instructions describe the procedure required and the injury which could result from failure to follow the procedure.



Hazards or unsafe practices which COULD result in minor personal injury or product or property damage. These instructions describe the requirements and the possible damage which could result from failure to follow the procedure.

NOTE

Instructions to aid in installation, operation, and maintenance or which clarify a procedure.

SAFETY - SECTION A

This information applies to 6400 Series[®] basic pumps. Gorman-Rupp has no control over or particular knowledge of the power source which will be used. Refer to the manual accompanying the power source before attempting to begin operation.

Because pump installations are seldom identical, this manual cannot possibly provide detailed instructions and precautions for each specific application. Therefore, it is the owner/installer's responsibility to ensure that applications not addressed in this manual are performed only after establishing that neither operator safety nor pump integrity are compromised by the installation.



Before attempting to open or service the pump:

1. Familiarize yourself with this manual.
2. Lock out or disconnect the power source to ensure that the pump will remain inoperative.
3. Allow the pump to completely cool if overheated.
4. Check the temperature before opening any covers, plates, or plugs.
5. Close the suction and discharge valves.
6. Vent the pump slowly and cautiously.
7. Drain the pump.



Death or serious personal injury and damage to the pump or components can occur if proper lifting procedures are not observed. Make certain that hoists, chains, slings or cables are in good working condition and of sufficient capacity and that they are positioned so that loads will be balanced and the pump or components will not be damaged when lifting. Suction and discharge hoses and piping must be removed from the pump before lifting. Lift the pump or component only as high as necessary and keep personnel away from suspended objects.



After the pump has been installed, make certain that the pump and all piping or hose connections are tight, properly supported and secure before operation.



Do not operate the pump without the shields and/or guards in place over the drive shaft, belts, and/or couplings, or other rotating parts. Exposed rotating parts can catch clothing, fingers, or tools, causing severe injury to personnel.



Do not operate the pump against a closed discharge valve for long periods of time. If operated against a closed dis-

charge valve, pump components will deteriorate, and the liquid could come to a boil, build pressure, and cause the pump casing to rupture or explode.



Overheated pumps can cause severe burns and injuries. If overheating of the pump occurs:

1. Stop the pump immediately.
2. Ventilate the area.
3. Allow the pump to completely cool.
4. Check the temperature before opening any covers, plates, gauges, or plugs.
5. Vent the pump slowly and cautiously.
6. Refer to instructions in this manual before restarting the pump.



Do not remove plates, covers, gauges, pipe plugs, or fittings from an overheated pump. Vapor pressure within the pump can cause parts being disengaged to be ejected with great force. Allow the pump to completely cool before servicing.



Never run this pump backwards. Be certain that rotation is correct before fully engaging the pump.

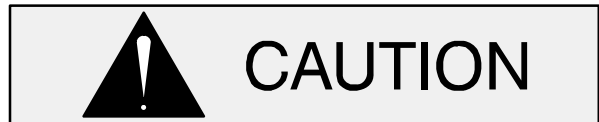

Pumps and related equipment must be installed and operated according to all national, local and industry standards.

INSTALLATION – SECTION B

Review all SAFETY information in Section A.

Since pump installations are seldom identical, this section offers only general recommendations and practices required to inspect, position, and arrange the pump and piping.

Most of the information pertains to a **flooded suction application** where the liquid is supplied to the pump under pressure. Since the pressure supplied to the pump is critical to performance and safety, **be sure** to limit the incoming pressure to

50% of the maximum permissible operating pressure as shown on the pump performance curve (see Section E, Page 1).

For further assistance, contact your Gorman-Rupp distributor or the Gorman-Rupp Company.

Pump Dimensions

See Figure 1 for the approximate physical dimensions of this pump.

OUTLINE DRAWING

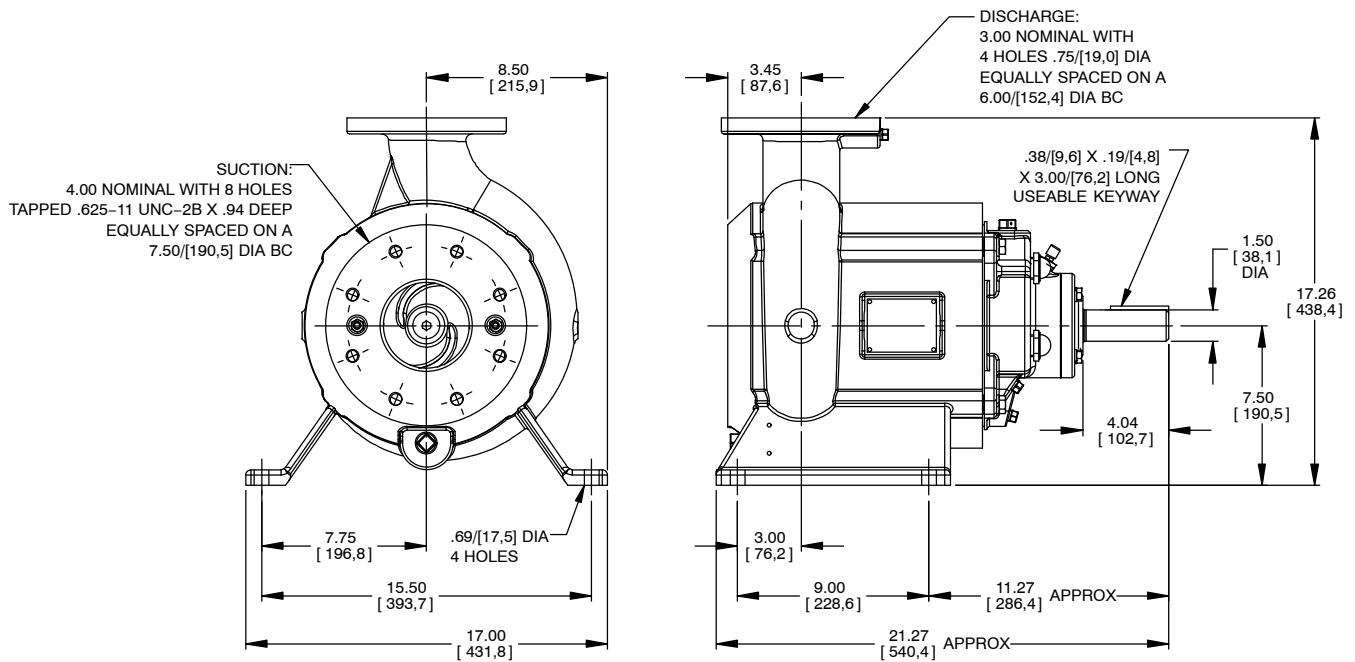

Figure 1. Pump Model 6403C60-B

PREINSTALLATION INSPECTION

The pump assembly was inspected and tested before shipment from the factory. Before installation, inspect the pump for damage which may have occurred during shipment. Check as follows:

- a. Inspect the pump for cracks, dents, damaged threads, and other obvious damage.

- b. Check for and tighten loose attaching hardware. Since gaskets tend to shrink after drying, check for loose hardware at mating surfaces.

- c. Carefully read all tags, decals, and markings on the pump assembly, and perform all duties indicated.

- d. Check levels and lubricate as necessary. Refer to **LUBRICATION** in the **MAINTENANCE**

AND REPAIR section of this manual and perform duties as instructed.

- e. If the pump has been stored for more than 12 months, some of the components or lubricants may have exceeded their maximum shelf life. These **must be inspected or replaced** to ensure maximum pump service.

If the maximum shelf life has been exceeded, or if anything appears to be abnormal, contact your Gorman-Rupp distributor or the factory to determine the repair or updating policy. **Do not** put the pump into service until appropriate action has been taken.

POSITIONING PUMP



Death or serious personal injury and damage to the pump or components can occur if proper lifting procedures are not observed. Make certain that hoists, chains, slings or cables are in good working condition and of sufficient capacity and that they are positioned so that loads will be balanced and the pump or components will not be damaged when lifting. Suction and discharge hoses and piping must be removed from the pump before lifting. Lift the pump or component only as high as necessary and keep personnel away from suspended objects.

Lifting

Pump unit weights will vary depending on the mounting and drive provided. Check the shipping tag on the unit packaging for the actual weight, and use lifting equipment with appropriate capacity. Drain the pump and remove all customer-installed equipment such as suction and discharge hoses or piping before attempting to lift existing, installed units.

Mounting

Locate the pump in an accessible place as close as practical to the liquid being pumped. Level mounting is essential for proper operation.

Proper mounting of the pump, driver and base is critical to the performance of the pump. Improper mounting can result in vibration, which can cause damage to the pump and/or other system components.

The pumping unit must be securely mounted to a foundation that is heavy enough to absorb any vibration, strain or shock, while providing permanent, rigid support for the unit.

Because pump installations vary due to the specific application, this manual cannot possibly anticipate and provide detailed instructions for every installation. Therefore, it is recommended that the installer of the unit follow the recommendations provided by the Hydraulic Institute in their Rotodynamic Centrifugal Pump Design and Application manual when designing and fabricating the foundation upon which the pump, base and driver will be mounted.

SUCTION AND DISCHARGE PIPING

The following is provided as general information for suction and discharge piping. Because pump installations vary due to the specific application, this manual cannot possibly anticipate and provide detailed instructions for every installation. Therefore, it is recommended that the installer follow the recommendations provided by the Hydraulic Institute in their Pump Piping for Rotodynamic Pumps manual for layout, design and installation of the system piping.

Materials

Materials used in piping must be compatible with the liquid being pumped. Using piping couplings in suction lines is not recommended.

Line Configuration

Keep suction and discharge lines as straight as possible to minimize friction losses. Make minimum use of elbows and fittings, which substantially increase friction loss. If elbows are necessary, use the long-radius type to minimize friction loss.

Connections to Pump

Before tightening a connecting flange, align it exactly with the pump port. Never pull a pipe line into place by tightening the flange bolts and/or couplings.

Lines near the pump must be independently supported to avoid strain on the pump which could cause excessive vibration, decreased bearing life, and increased shaft and seal wear.

Gauges

Most pumps are drilled and tapped for installing discharge pressure and vacuum suction gauges. If these gauges are desired for pumps that are not tapped, drill and tap the suction and discharge lines not less than 18 inches (457,2 mm) from the suction and discharge ports and install the lines. Installation closer to the pump may result in erratic readings.

SUCTION LINES

To avoid air pockets which could affect pump priming, the suction line must be as short and direct as possible.

Fittings

Suction lines should be the same size as the pump inlet. If reducers are used in suction lines, they should be the eccentric type, and should be installed with the flat part of the reducers uppermost to avoid creating air pockets. Valves are not normally used in suction lines, but if a valve is used for isolation purposes, install it with the stem horizontal to avoid air pockets.

Strainers

A strainer or other device should be used to filter solids larger than the pump's capacity to avoid damage or decreased performance. Information about solids size handling can be found on the performance curve for your specific pump. When selecting or installing a strainer, make certain that the total area of the openings in the strainer is at least three or four times the cross section of the suction line, and the openings will not permit passage of

solids larger than the solids handling capability of the pump.

Sealing

Since even a slight leak will affect pump performance, all connections in the suction line should be sealed with pipe dope to ensure an airtight seal. Follow the sealant manufacturer's recommendations when selecting and applying the pipe dope. The pipe dope should be compatible with the liquid being pumped.

DISCHARGE LINES

Siphoning

Do not terminate the discharge line at a level lower than that of the liquid being pumped unless a siphon breaker is used in the line. Otherwise, a siphoning action causing damage to the pump could result.

Valves

If a throttling valve is desired in the discharge line, use a valve as large as the largest pipe to minimize friction losses. Never install a throttling valve in a suction line.

With high discharge heads, it is recommended that a throttling valve and a system check valve be installed in the discharge line to protect the pump from excessive shock pressure and reverse rotation when it is stopped.



If the application involves a high discharge head, gradually close the discharge throttling valve before stopping the pump.

ALIGNMENT

The alignment of the pump and its power source is critical for trouble-free mechanical operation. In either a flexible coupling or V-belt driven system, the driver and pump must be mounted so that their shafts are aligned with and parallel to each other. It is imperative that alignment be checked after the

pump and piping are installed, and before operation.

NOTE

Check **Rotation**, before final alignment of the pump.



When checking alignment, disconnect the power source to ensure that the pump will remain inoperative.

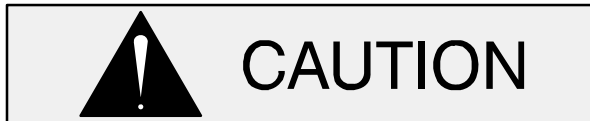

Adjusting the alignment in one direction may alter the alignment in another direction. Check each procedure after altering alignment.

Coupled Drives

When using couplings, the axis of the power source must be aligned to the axis of the pump shaft in both the horizontal and vertical planes. Most couplings require a specific gap or clearance between the driving and the driven shafts. Refer to the coupling manufacturer's service literature.

Align spider insert type couplings by using calipers to measure the dimensions on the circumference of the outer ends of the coupling hub every 90° . The coupling is in alignment when the hub ends are the same distance apart at all points (see Fig. 2)

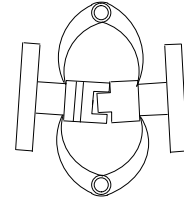

Figure 2. Aligning Spider-Type Couplings

Align non-spider type couplings by using a feeler gauge or taper gauge between the coupling halves every 90° . The coupling is in alignment when the hubs are the same distance apart at all points (see Figure 3).

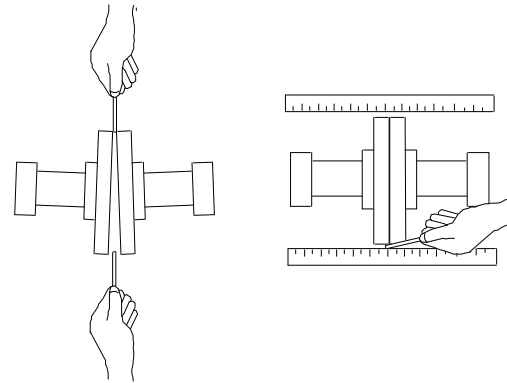
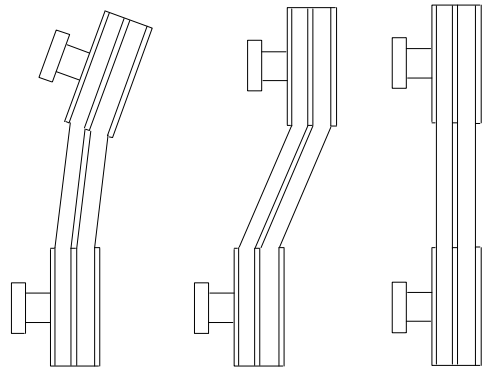

Figure 3. Aligning Non-Spider Type Couplings

Check parallel adjustment by laying a straightedge across both coupling rims at the top, bottom, and side. When the straightedge rests evenly on both halves of the coupling, the coupling is in horizontal parallel alignment. If the coupling is misaligned, use a feeler gauge between the coupling and the straightedge to measure the amount of misalignment.

Drive Belts

When using drive belts, the power source and the pump must be parallel. Use a straightedge along the sides of the pulleys to ensure that the pulleys are properly aligned (see Figure 4). In drive systems using two or more belts, make certain that the belts are a matched set; unmatched sets will cause accelerated belt wear.



**MISALIGNED:
SHAFTS
NOT PARALLEL**

**MISALIGNED:
SHAFTS
NOT IN LINE**

**ALIGNED: SHAFTS
PARALLEL AND
SHEAVES IN LINE**

Figure 4. Alignment of V-Belt Driven Pumps

Tighten the belts in accordance with the belt manufacturer's instructions. If the belts are too loose, they will slip; if the belts are too tight, there will be excessive power loss and possible bearing failure. Select pulleys that will match the proper speed ratio; overspeeding the pump may damage both pump and power source.



Do not operate the pump without the guard in place over the rotating parts. exposed rotating parts can catch clothing, fingers, or tools, causing severe injury to personnel.

DRIVE BELT TENSIONING

General Rules of Tensioning

For new drive belts, check the tension after 5, 20 and 50 hours of operation and re-tension as required (see the following procedure for measuring belt tension). Thereafter, check and re-tension if required monthly or at 500 hour intervals, whichever comes first.

Ideal drive belt tension is the **lowest** tension at which the belt will not slip under peak load conditions. Do not over-tension drive belts. Over-tensioning will shorten both drive belt and bearing life. Under-tensioning will cause belt slippage. Always keep belts free from dirt, grease, oil and other foreign material which may cause slippage.

OPERATION – SECTION C

Review all SAFETY information in Section A.

Follow the instructions on all tags, labels and decals attached to the pump.



This pump is designed to handle most non-volatile, non-flammable liquids containing specified entrained solids. Do not attempt to pump volatile, corrosive, or flammable liquids which may damage the pump or endanger personnel as a result of pump failure.

STARTING

Consult the operations manual furnished with the power source.

OPERATION

Leakage

No leakage should be visible at pump mating surfaces, or at pump connections or fittings. Keep all line connections and fittings tight to maintain maximum pump efficiency.

Liquid Temperature And Overheating

The **maximum** liquid temperature for this pump is 160°F (71°C). Do not apply it at a higher operating temperature.

Overheating can occur if operated with the valves in the suction or discharge lines closed. Operating against closed valves could bring the liquid to a boil, build pressure, and cause the pump to rupture or explode. If overheating occurs, stop the pump and allow it to cool before servicing it. Refill the pump casing with cool liquid.



Allow an over-heated pump to cool before servicing. Do not remove plates, covers, gauges, or fittings from an over-heated pump. Liquid within the pump can reach boiling temperatures, and vapor pressure within the pump can cause parts being disengaged to be ejected with great force. **After the pump cools,** drain the liquid from the pump by removing the casing drain plug. Use caution when removing the plug to prevent injury to personnel from hot liquid.

Strainer Check

If a suction strainer has been installed by the user, check the strainer regularly and clean it as necessary. The strainer should also be checked if pump flow rate begins to drop. If a vacuum suction gauge has been installed, monitor and record the readings regularly to detect strainer blockage.

Never introduce air or steam pressure into the pump casing or piping to remove a blockage. This could result in personal injury or damage to the equipment. If backflushing is absolutely necessary, **liquid pressure** must be limited to 50% of the maximum permissible operating pressure shown on the pump performance curve (see Section E, Page 1).

STOPPING

If the liquid being pumped is stopped abruptly, damaging shock waves can be transmitted to the pump and piping system. Soft-start systems with ramp up/ramp down starting and stopping capabilities are available where water hammer may be a problem.

After stopping the pump, lock out or disconnect the power source to ensure that the pump will remain inoperative.

Cold Weather Preservation

In below freezing conditions, drain the pump to prevent damage from freezing. Also, clean out any solids by flushing with a hose. Operate the pump for approximately one minute; this will remove any remaining liquid that could freeze the pump rotating parts. If the pump will be idle for more than a few hours, or if it has been pumping liquids containing a large amount of solids, drain the pump, and flush it thoroughly with clean water. To prevent large solids from clogging the drain port and preventing the pump from completely draining, insert a rod or stiff wire in the drain port, and agitate the liquid during the draining process. Clean out any remaining solids by flushing with a hose.

BEARING TEMPERATURE CHECK

Bearings normally run at higher than ambient temperatures because of heat generated by friction.

Temperatures up to 160°F (71°C) are considered normal for bearings, and they can operate safely to at least 180°F (82°C).

Checking bearing temperatures by hand is inaccurate. Bearing temperatures can be measured accurately by placing a contact-type thermometer against the housing. Record this temperature for future reference.

A sudden increase in bearing temperatures is a warning that the bearings are at the point of failing to operate properly. Make certain that the bearing lubricant is of the proper viscosity and at the correct level (see **LUBRICATION** in Section E). Bearing overheating can also be caused by shaft misalignment and/or excessive vibration.

When pumps are first started, the bearings may seem to run at temperatures above normal. Continued operation should bring the temperatures down to normal levels.

TROUBLESHOOTING – SECTION D

Review all SAFETY information in Section A.



Before attempting to open or service the pump:

1. Familiarize yourself with this manual.
2. Lock out or disconnect the power source and take the necessary precautions to ensure that the pump will remain inoperative.
3. Allow the pump to completely cool if overheated.
4. Check the temperature before opening any covers, plates, or plugs.
5. Close the suction and discharge valves.
6. Vent the pump slowly and cautiously.
7. Drain the pump.

Table D-1 Troubleshooting Chart

TROUBLE	POSSIBLE CAUSE	PROBABLE REMEDY
PUMP STOPS OR FAILS TO DELIVER RATED FLOW OR PRESSURE	Air leak in suction line. Lining of suction hose collapsed. Suction intake not submerged at proper level or sump too small. Strainer clogged.	Correct leak. Replace suction hose. Check installation and correct submergence as needed. Check strainer and clean if necessary.

Table D-1 Troubleshooting Chart (Continued)

TROUBLE	POSSIBLE CAUSE	PROBABLE REMEDY
PUMP STOPS OR FAILS TO DELIVER RATED FLOW OR PRESSURE (cont.)	<p>Impeller or other wearing parts worn or damaged.</p> <p>Leaking or worn seal or pump gasket.</p> <p>Impeller clogged.</p> <p>Pump running backwards (electric motor driven models).</p> <p>Suction lift or discharge head too high.</p> <p>Liquid solution too thick.</p>	<p>Replace worn or damaged parts. Check that impeller is properly centered and rotates freely.</p> <p>Check pump vacuum. Replace leaking or worn seal or gasket.</p> <p>Free impeller of debris.</p> <p>Check direction of rotation. Correct 3-phase wiring by interchanging any two motor leads at control box. (See Pump Rotation in the Installation and Operations Manual.)</p> <p>Check piping installation and install bypass line if needed. See INSTALLATION in the Installation and Operations manual.</p> <p>Dilute if possible.</p>
PUMP REQUIRES TOO MUCH POWER	<p>Pump speed too high.</p> <p>Discharge head too low.</p> <p>Liquid solution too thick.</p> <p>Impeller jammed due to debris or insufficient clearance.</p>	<p>Check governor setting (engine driven models).</p> <p>Adjust discharge valve.</p> <p>Dilute if possible.</p> <p>Disassemble pump and check impeller.</p>
PUMP CLOGS FREQUENTLY	<p>Discharge flow too slow.</p> <p>Suction check valve or foot valve clogged or binding.</p>	<p>Open discharge valve fully to increase flow rate, and run power source at maximum governed speed.</p> <p>Clean valve.</p>
EXCESSIVE NOISE	<p>Cavitation in pump.</p> <p>Pumping entrained air.</p> <p>Pump or drive not securely mounted.</p> <p>Impeller clogged or damaged.</p>	<p>Reduce suction lift and/or friction losses in suction line. Record vacuum and pressure gauge readings and consult local representative or factory.</p> <p>Locate and eliminate source of air bubble.</p> <p>Secure mounting hardware.</p> <p>Clean out debris; replace damaged parts.</p>

Table D-1 Troubleshooting Chart (Continued)

TROUBLE	POSSIBLE CAUSE	PROBABLE REMEDY
BEARINGS RUN TOO HOT	Bearing temperature is high, but within limits.	Check bearing temperature regularly to monitor any increase
	Low or incorrect lubricant.	Check for proper type and level of lubricant.

PREVENTIVE MAINTENANCE

Since pump applications are seldom identical, and pump wear is directly affected by such things as the abrasive qualities, pressure and temperature of the liquid being pumped, this section is intended only to provide general recommendations and practices for preventive maintenance. Regardless of the application however, following a routine preventive maintenance schedule will help assure trouble-free performance and long life from your Gorman-Rupp pump. For specific questions concerning your application, contact your Gorman-Rupp distributor or the Gorman-Rupp Company.

Record keeping is an essential component of a good preventive maintenance program. Changes in suction and discharge gauge readings (if so

equipped) between regularly scheduled inspections can indicate problems that can be corrected before system damage or catastrophic failure occurs. The appearance of wearing parts should also be documented at each inspection for comparison as well. Also, if records indicate that a certain part (such as the seal) fails at approximately the same duty cycle, the part can be checked and replaced before failure occurs, reducing unscheduled down time.

For new applications, a first inspection of wearing parts at 250 hours will give insight into the wear rate for your particular application. Subsequent inspections should be performed at the intervals shown on the chart below. Critical applications should be inspected more frequently.

Preventive Maintenance Schedule					
Item	Service Interval*				
	Daily	Weekly	Monthly	Semi-Annually	Annually
General Condition (Temperature, Unusual Noises or Vibrations, Cracks, Leaks, Loose Hardware, Etc.)	I				
Pump Performance (Gauges, Speed, Flow)	I				
Bearing Lubrication		I			R
Seal Lubrication (And Packing Adjustment, If So Equipped)		I			R
V-Belts (If So Equipped)			I		
Air Release Valve Plunger Rod (If So Equipped)			I	C	
Front Impeller Clearance (Wear Plate)				I	
Rear Impeller Clearance (Seal Plate)				I	
Check Valve					I
Pressure Relief Valve (If So Equipped)					C
Pump and Driver Alignment					I
Shaft Deflection					I
Bearings					I
Bearing Housing					I
Piping					I
Driver Lubrication – See Mfgr’s Literature					I
<p>Legend: I = Inspect, Clean, Adjust, Repair or Replace as Necessary C = Clean R = Replace</p> <p>* Service interval based on an intermittent duty cycle equal to approximately 4000 hours annually. Adjust schedule as required for lower or higher duty cycles or extreme operating conditions.</p>					

PUMP MAINTENANCE AND REPAIR - SECTION E

MAINTENANCE AND REPAIR OF THE WEARING PARTS OF THE PUMP WILL MAINTAIN PEAK OPERATING PERFORMANCE.

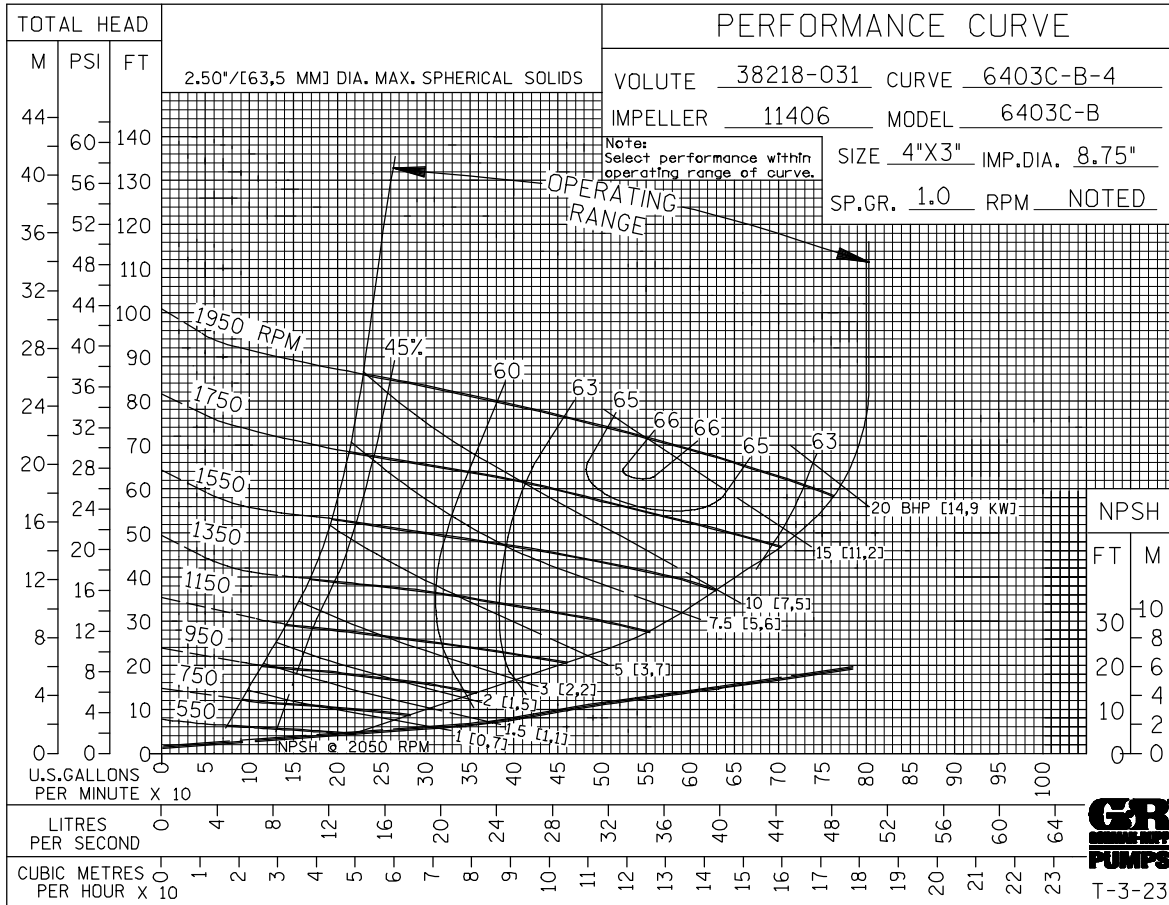

*** STANDARD PERFORMANCES FOR PUMP MODEL 6403C60-B**

* Based on 70°F (21°C) clear water at sea level with minimum suction lift. Since pump installations are seldom identical, your performance may be difference due to such factors as viscosity, specific gravity, elevation, temperature, and impeller trim.

Contact the Gorman-Rupp Company to verify performance or part numbers.



CAUTION

If your pump serial number is followed by an "N", your pump is **NOT** a standard production model.

Pump speed and operating condition points must be within the continuous performance range shown on the curve.

ILLUSTRATION

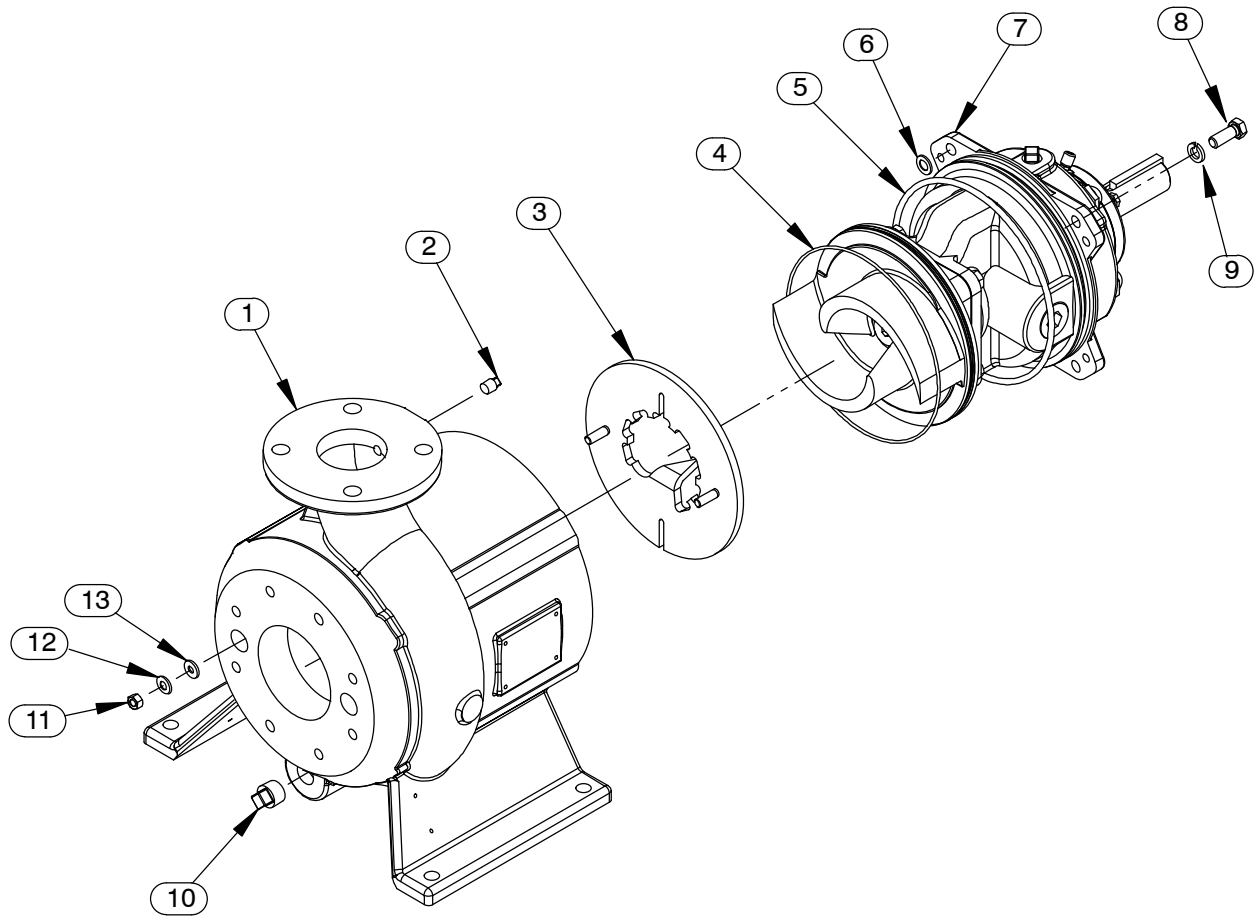

Figure 1. Pump Assembly 6403C60-B

PARTS LIST
Pump Assembly 6403C60-B
 (From S/N 1799718 Up)

If your pump serial number is followed by an "N", your pump is **NOT** a standard production model. Contact the Gorman-Rupp Company to verify part numbers.

ITEM NO.	PART NAME	PART NUMBER	QTY
1	PUMP CASING	38218-031 11010	1
2	PIPE PLUG	P04 15079	1
3	WEAR PLATE ASSEMBLY	46451-777 24150	1
4	* O-RING	25152-269	1
5	* O-RING	S1748	1
6	ADJ SHIM SET	13130 17040	4
7	REPAIR ROTATING ASSEMBLY	44163-880	1
8	HEX HEAD CAP SCREW	B0805-1/2 15991	4
9	LOCK WASHER	J08 15991	4
10	PIPE PLUG	P12 15070	1
11	HEX NUT	D06 15991	2
12	FLAT WASHER	KE06 15991	2
13	SEALING WASHER 3/8	25123-026	2
NOT SHOWN:			
	NAMEPLATE BLANK	38819-004 13000	1
	DRIVE SCREW	BM#04-03 17000	4
	SUCTION STICKER	6588AG	1
	DISCHARGE STICKER	6588BJ	1
	LUBRICATION DECAL	38817-084	1
	INSTRUCTION TAG	38817-011	1
	INSTRUCTION TAG	38817-024	1
	WARNING DECAL	2613FE	1
	G-R DECAL	GR-03	1
	ROTATION DECAL	2613M	1
	ERADICATOR DECAL	38812-111	1

* INDICATES PARTS RECOMMENDED FOR STOCK

ILLUSTRATION

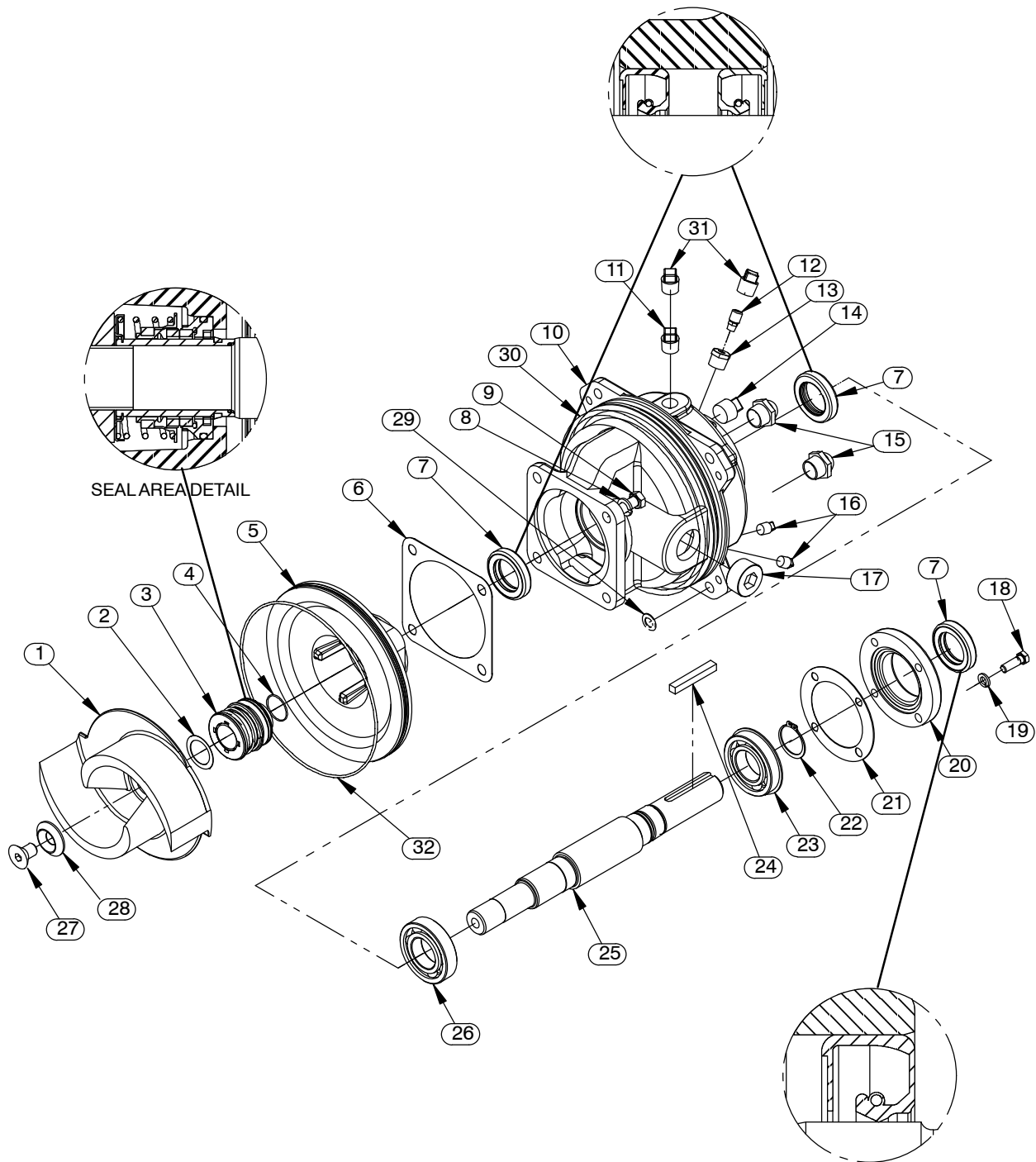

Figure 2. Repair Rotating Assembly

PARTS LIST
Repair Rotating Assembly

ITEM NO.	PART NAME	PART NUMBER	QTY
1	IMPELLER	11406 11010	1
2	* ADJ SHIM SET	37J 17090	1
3	* 1.50 SEAL ASSY	46513-151	1
4	* O-RING	25154-022	1
5	SEAL PLATE	38272-279 11010	1
6	* GASKET	10959G 20000	1
7	* OIL SEAL	S1352	3
8	LOCK WASHER	J08 15991	4
9	HEX HEAD CAP SCREW	B0805 15991	4
10	BEARING HOUSING	38251-410 10010	1
11	VENTED PIPE PLUG	4823A 15079	1
12	AIR VENT	S1530	1
13	REDUCER PIPE BUSHING	AP0802 15079	1
14	PIPE PLUG	P12 15079	1
15	SIGHT GAUGE	S1471	2
16	PIPE PLUG	P04 15079	2
17	SOC HD PIPE PLUG	PC20 10009	1
18	HEX HEAD CAP SCREW	B0605 15991	4
19	LOCK WASHER	J06 15991	4
20	BEARING CAP	38322-219 10010	1
21	* GASKET	38683-268 18000	1
22	SNAP RING	S244	1
23	* BALL BEARING	S1749	1
24	* KEY	N0611 15990	1
25	IMPELLER SHAFT	38514-563 16040	1
26	* BALL BEARING	23252-013	1
27	FLAT HEAD SOCKET SCREW	F1004S 1500G	1
28	IMPELLER WASHER	31167-029 16000	1
29	ADJ SHIM SET	13130 17040	4
30	* O-RING	S1748	1
31	SHIPPING PLUG	11495B 15079	2
32	* O-RING	25152-269	1
NOT SHOWN:			
	DRIVE SCREW	BM#04-03 17000	2
	ASSEMBLY PLATE	2613GG 13990	1
	ROTATION DECAL	2613M	1
	INSTRUCTION TAG	6588U	1

* INDICATES PARTS RECOMMENDED FOR STOCK

PUMP AND SEAL DISASSEMBLY AND REASSEMBLY

Review all SAFETY information in Section A.

Follow the instructions on all tags, label and decals attached to the pump.

This pump requires little service due to its rugged, minimum-maintenance design. However, if it becomes necessary to inspect or replace the wearing parts, follow these instructions which are keyed to the illustrations (see Figures 1 and 2) and the corresponding parts lists.

Some pump service functions may be performed without separating the pump end assembly from the engine. However, the following instructions assume complete disassembly of the pump is required.

Before attempting to service the pump, lock out or disconnect the power source and take precautions to ensure that it will remain inoperative. Close all valves in the suction and discharge lines and drain the pump casing by removing the lowermost pipe plug (10, Figure 1). Clean and reinstall the pipe plug.



This manual will alert personnel to known procedures which require special attention, to those which could damage equipment, and to those which could be dangerous to personnel. However, this manual cannot possibly anticipate and provide detailed instructions and precautions for every situation that might occur during maintenance of the unit. Therefore, it is the responsibility of the owner/maintenance personnel to ensure that only safe, established maintenance procedures are used, and that any procedures not addressed in this manual are performed only after establishing that neither personal safety nor pump integrity are compromised by such practices.



Before attempting to open or service the pump:

1. Familiarize yourself with this manual.
2. Lock out or disconnect the power source to ensure that the pump will remain inoperative.
3. Allow the pump to completely cool if overheated.
4. Check the temperature and make sure it is cool before opening any covers, plates, gauges, or plugs.
5. Close the suction and discharge valves.
6. Vent the pump slowly and cautiously.
7. Drain the pump.



Death or serious personal injury and damage to the pump or components can occur if proper lifting procedures are not observed. Make certain that hoists, chains, slings or cables are in good working condition and of sufficient capacity and that they are positioned so that loads will be balanced and the pump or components will not be damaged when lifting. Suction and discharge hoses and piping must be removed from the pump before lifting. Lift the pump or component only as high as necessary and keep personnel away from suspended objects.

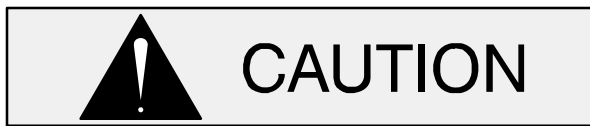

Use **Only Genuine Gorman–Rupp** replacement parts. Failure to do so may create a hazard and damage the pump or diminish optimal pump performance. Any such hazard, damage or diminished performance is not covered by the warranty.

NOTE

When appropriate recycling facilities are available, the user should recycle components and fluids when doing any routine maintenance / repairs and also at the end of the pump's useful life. All other components and fluids shall be disposed of according to all applicable codes and regulations.

Rotating Assembly Removal

(Figure 2)

The rotating assembly may be serviced without disconnecting the suction or discharge piping; however, the power source must be removed to provide clearance.

(Figure 1)

Remove the hardware (8 and 9) securing the rotating assembly to the pump casing. Separate the rotating assembly by pulling straight away from the pump casing.

NOTE

An optional disassembly tool is available from the factory. If the tool is used, follow the instructions packed with it. A similar tool may be assembled using 1/2-inch pipe (schedule 80 steel or malleable iron) and a standard tee (see Figure 3). All threads are 1/2-inch NPT. Do not pre-assemble the tool.

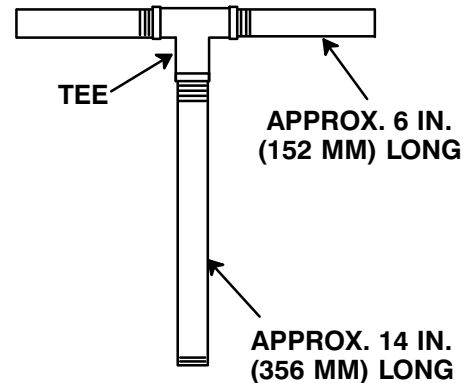

Figure 3. Rotating Assembly Tool

To install the tool, remove the vented plug (11, Figure 2) from the bearing housing, and screw the longest length of pipe into the vent hole until fully engaged. Install the tee, and screw the handles into the tee. Use caution when lifting the rotating assembly to avoid injury to personnel or damage to the assembly.

Remove the bearing housing O-ring (30).

Draining Oil From Seal Cavity

(Figure 2)

If any further disassembly is to be performed on the pump, the seal oil cavity must be drained to prevent the oil in the seal cavity from escaping as the impeller is removed.

Position a **clean** container under the seal cavity drain plug (16). Remove the plug and drain the oil from the seal cavity into the container. Clean and reinstall the drain plug. Inspect the oil for water, dirt or a cloudy condition which could indicate seal failure.

Impeller Removal

(Figure 2)

With the rotating assembly removed secure to floor or workbench and immobilize the impeller by wedging a block of wood between the vanes. Remove the impeller capscrew and lock washer (27 and 28). If removed, install the shaft key (24). Install a lathe dog on the drive end of the shaft (25) with the "V" notch positioned over the shaft keyway.

With the impeller rotation still blocked, strike the lathe dog sharply in a counterclockwise direction (when facing the drive end of the shaft). The impeller may also be loosened by using a long piece of heavy bar stock to pry against the arm of the lathe dog in a counterclockwise direction (when facing the drive end of the shaft) as shown in Figure 4. **Use caution** not to damage the shaft or keyway. When the impeller breaks loose, remove the lathe dog and wood block and unscrew the impeller from the shaft. Use caution when unscrewing the impeller; tension on the shaft seal spring will be released as the impeller is removed. Inspect the impeller and replace if cracked or badly worn.

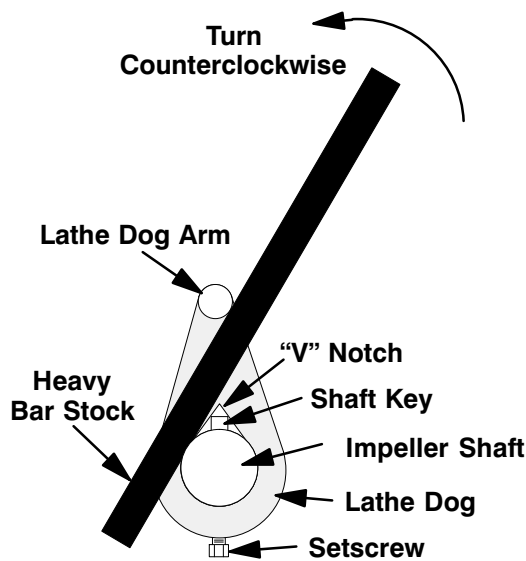

Figure 4. Loosening Impeller

Seal Removal

(Figure 2)

Slide the shaft sleeve and rotating portion of the seal off the shaft as a unit.

Use a pair of stiff wires with hooked ends to remove the stationary element and seat.

An alternate method of removing the stationary seal components is to remove the hardware (8 and 9) and separate the seal plate (5) and gasket (6) from the bearing housing (10). Position the seal plate on a flat surface with the impeller side down. Use a wooden dowel or other suitable tool to press on the back side of the stationary seat until the

seat, O-rings, and stationary element can be removed.

Remove the shaft sleeve O-ring (4).

Shaft and Bearing Removal and Disassembly (Figure 2)

When the pump is properly operated and maintained, the bearing housing should not require disassembly. Disassemble the shaft and bearings **only** when there is evidence of wear or damage.



Shaft and bearing disassembly in the field is not recommended. These operations should be performed only in a properly equipped shop by qualified personnel.

Remove the bearing housing drain plug (16) and drain the lubricant. Clean and reinstall the drain plug.

Disengage the hardware (18 and 19) and slide the bearing cap (20) and oil seal (7) off the shaft. Remove the bearing cap gasket (21), and press the oil seal from the bearing cap.

Place a block of wood against the impeller end of the shaft (25) and tap the shaft and assembled bearings (23 and 26) from the bearing housing.

Pry or press the oil seals (7) from the bearing housing.

After removing the shaft and bearings, clean and inspect the bearings **in place** as follows.



To prevent damage during removal from the shaft, it is recommended that bearings be cleaned and inspected **in place**. It is **strongly** recommended that the bearings be replaced **any** time the shaft and bearings are removed.

Clean the bearing housing, shaft and all component parts (except the bearings) with a soft cloth

soaked in cleaning solvent. Inspect the parts for wear or damage and replace as necessary.



Most cleaning solvents are toxic and flammable. Use them only in a well ventilated area free from excessive heat, sparks, and flame. Read and follow all precautions printed on solvent containers.

Clean the bearings thoroughly in **fresh** cleaning solvent. Dry the bearings with filtered compressed air and coat with light oil.

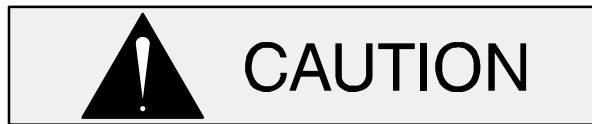

Bearings must be kept free of all dirt and foreign material. Failure to do so will greatly shorten bearing life. **Do not** spin dry bearings. This may scratch the balls or races and cause premature bearing failure.

Rotate the bearings by hand to check for roughness or binding and inspect the bearing balls. If rotation is rough or the bearing balls are discolored, replace the bearings.

The bearing tolerances provide a tight press fit onto the shaft and a snug slip fit into the bearing housing. Replace the bearings, shaft, or bearing housing if the proper bearing fit is not achieved.

If bearing replacement is required, remove the outboard bearing snap ring (22), and use a bearing puller to remove the bearings from the shaft.

Shaft and Bearing Reassembly and Installation

(Figure 2)

Clean the bearing housing, shaft and all component parts (except the bearings) with a soft cloth soaked in cleaning solvent. Inspect the parts for wear or damage as necessary.



Most cleaning solvents are toxic and flammable. Use them only in a well ventilated area free from excessive heat, sparks, and flame. Read and follow all precautions printed on solvent containers.

Inspect the shaft for distortion, nicks or scratches, or for thread damage on the impeller end. Dress small nicks and burrs with a fine file or emery cloth. Replace the shaft if defective.

Position the inboard oil seal (7) in the bearing housing bore with the lip positioned as shown in Figure 2. Press the oil seal into the housing until the face is **just flush** with the counterbored surface toward the inside of the bearing housing. Inspect for and remove any sealant shavings that might be removed from the O.D. of the oil seal.

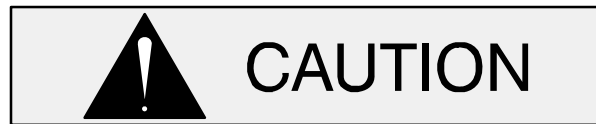

To prevent damage during removal from the shaft, it is recommended that bearings be cleaned and inspected **in place**. It is **strongly** recommended that the bearings be replaced **any** time the shaft and bearings are removed.

NOTE

Position the inboard bearing (26) on the shaft with the shielded side toward the impeller end of the shaft. Position the outboard bearing (23) on the shaft with the integral retaining ring on the bearing O.D. toward the drive end of the shaft.

The bearings may be heated to ease installation. An induction heater, hot oil bath, electric oven, or hot plate may be used to heat the bearings. Bearings should **never** be heated with a direct flame or directly on a hot plate.

NOTE

*If a hot oil bath is used to heat the bearings, both the oil and the container must be **absolutely** clean. If the oil has been previously used, it must be **thor-***

roughly filtered.

Heat the bearings to a uniform temperature **no higher than** 250°F (120°C) and slide the bearings onto the shaft, one at a time, until they are fully seated. This should be done quickly, in one continuous motion, to prevent the bearings from cooling and sticking on the shaft.

After the bearings have been installed and allowed to cool, check to ensure that they have not moved away from the shaft shoulders in shrinking. If movement has occurred, use a suitably sized sleeve and a press to reposition the bearings against the shaft shoulders.

If heating the bearings is not practical, use a suitably sized sleeve, and an arbor (or hydraulic) press to install the bearings on the shaft.

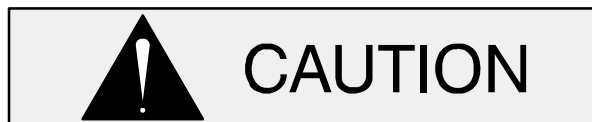

When installing the bearings onto the shaft, **never** press or hit against the outer race, balls, or ball cage. Press **only** on the inner race.

Secure the outboard bearing on the shaft with the bearing snap ring (22).

Slide the shaft and assembled bearings into the bearing housing until the retaining ring on the outboard bearing seats against the bearing housing.



When installing the shaft and bearings into the bearing bore, push against the outer race. **Never** hit the balls or ball cage.

Position the outboard oil seal (7) in the bearing housing bore with the lip positioned as shown in Figure 2. Press the oil seal into the housing until the face is **just flush** with the machined surface on the bearing housing. Inspect for and remove any sealant shavings that might be removed from the O.D. of the oil seal.

Press the oil seal (7) into the bearing cap (20) with the lip positioned as shown in Figure 2. Replace

the bearing cap gasket (21) and secure the bearing cap with the hardware (18 and 19). **Be careful** not to damage the oil seal lip on the shaft keyway.

Lubricate the bearing housing as indicated in **LUBRICATION**.

Seal Installation

(Figures 2 and 4)



Most cleaning solvents are toxic and flammable. Use them only in a well ventilated area free from excessive heat, sparks, and flame. Read and follow all precautions printed on solvent containers.

Clean the seal cavity and shaft with a cloth soaked in fresh cleaning solvent. Inspect the stationary seat bore in the seal plate for dirt, nicks and burrs, and remove any that exist. The stationary seat bore **must** be completely clean before installing the seal.

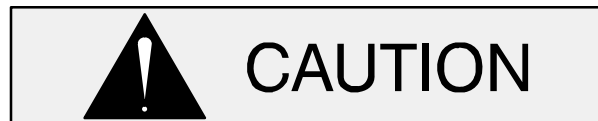

A new seal assembly should be installed **any time** the old seal is removed from the pump. Wear patterns on the finished faces cannot be realigned during reassembly. Reusing an old seal could result in premature failure.

The seal is not normally reused because wear patterns on the finished faces cannot be realigned during reassembly. This could result in premature failure. If necessary to reuse an old seal in an emergency, **carefully** wash all metallic parts in fresh cleaning solvent and allow to dry thoroughly.

Inspect the seal components for wear, scoring, grooves, and other damage that might cause leakage. If any components are worn, replace the complete seal; **never mix old and new seal parts.**

If a replacement seal is being used, remove it from the container and inspect the precision finished faces to ensure that they are free of any foreign matter.

To ease installation of the seal, lubricate the shaft sleeve O-ring and the external stationary seat O-ring with a very **small** amount of “P-80® Emulsion” or water.

See Figure 5 for seal part identification.

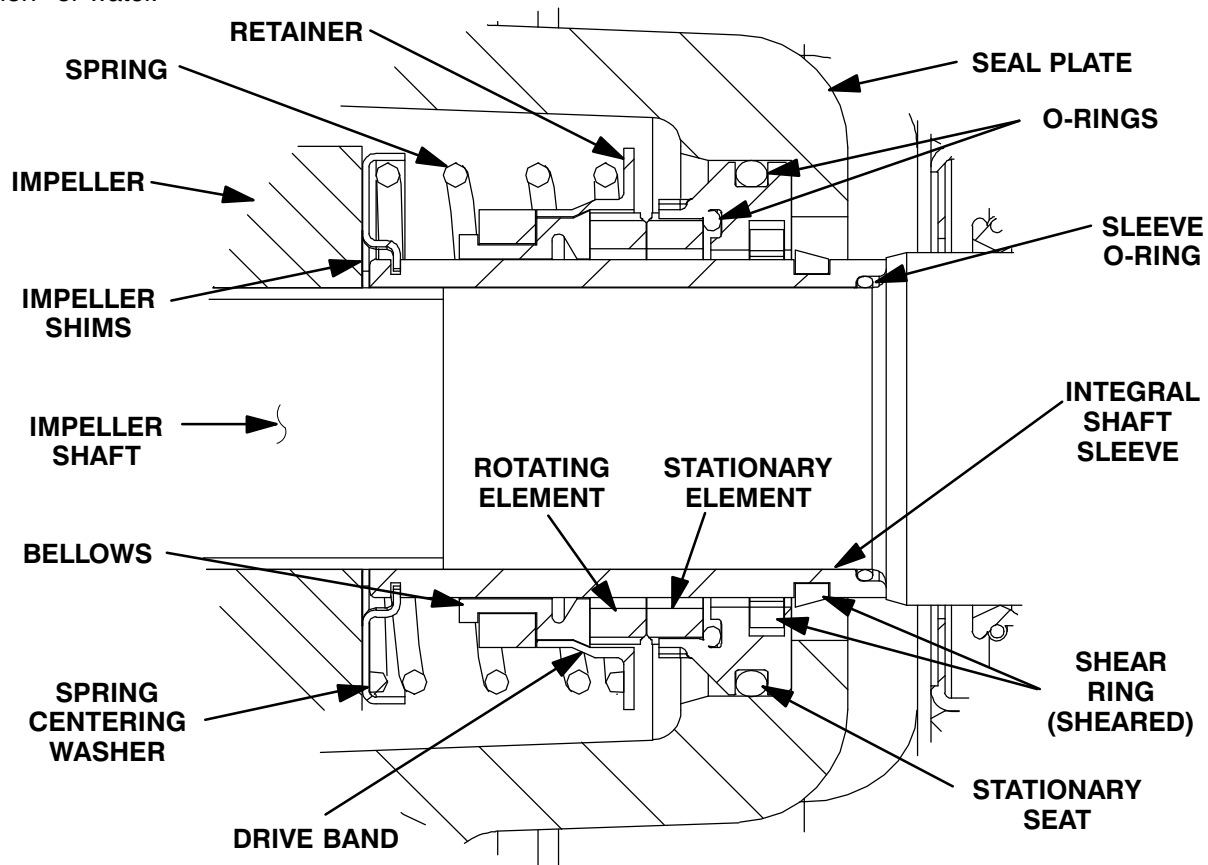

Figure 5. Cartridge Seal Assembly



This seal is not designed for operation at temperatures above 160°F (71°C). Do not use at higher operating temperatures.

If the seal plate was removed, install the seal plate gasket (6). Position the seal plate over the shaft and secure it to the bearing housing with the hardware (8 and 9).

To prevent damaging the shaft sleeve O-ring (4) on the shaft threads, cover the threads with electrical or duct tape. Slide the O-ring over the shaft until it

seats against the shaft shoulder. Remove the tape covering the threads. Check to ensure that the shaft threads are free of any tape residue and clean as required before proceeding with seal installation.

Slide the seal assembly onto the shaft until the external stationary seat O-ring engages the bore in the seal plate.

Clean and inspect the impeller as described in **Impeller Installation**. Screw the impeller onto the shaft until it is seated against the seal (see Figure 5).

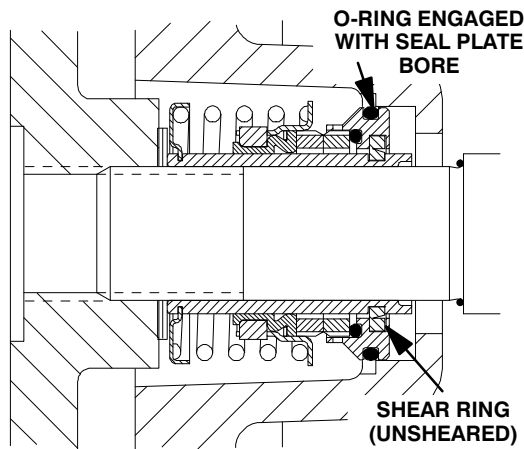

Figure 5. Seal Partially Installed

Continue to screw the impeller onto the shaft. This will press the stationary seat into the seal plate bore.

NOTE

A firm resistance will be felt as the impeller presses the stationary seat into the seal plate bore.

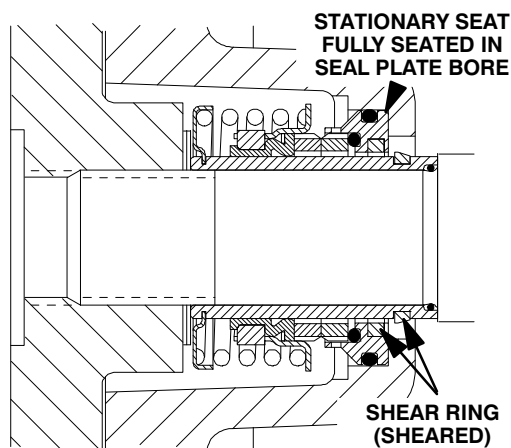
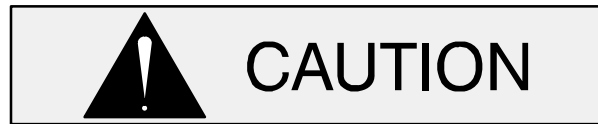

Figure 6. Seal Fully Installed

As the stationary seat becomes fully seated, the seal spring compresses, and the shaft sleeve will break the nylon shear ring. This allows the sleeve to slide down the shaft until seated against the shaft shoulder. Continue to screw the impeller onto the shaft until the impeller, shims, and sleeve are fully seated against the shaft shoulder (see Figure 6).

If necessary to reuse an old seal in an emergency, carefully separate the rotating and stationary seal faces from the bellows retainer and stationary seat.



A new seal assembly should be installed **any time** the old seal is removed from the pump. Wear patterns on the finished faces cannot be realigned during reassembly. Reusing an old seal could result in premature failure.

Handle the seal parts with extreme care to prevent damage. Be careful not to contaminate precision finished faces; even fingerprints on the faces can shorten seal life. If necessary, clean the faces with a non-oil based solvent and a clean, lint-free tissue. Wipe **lightly** in a concentric pattern to avoid scratching the faces.

Carefully wash all metallic parts in fresh cleaning solvent and allow to dry thoroughly.



Do not attempt to separate the rotating portion of the seal from the shaft sleeve when reusing an old seal. The rubber bellows will adhere to the sleeve during use, and attempting to separate them could damage the bellows.

Inspect the seal components for wear, scoring, grooves, and other damage that might cause leakage. Inspect the integral shaft sleeve for nicks or cuts on either end. If any components are worn, or the sleeve is damaged, replace the complete seal; **never mix old and new seal parts.**

Install the stationary seal element in the stationary seat. Press this stationary subassembly into the seal plate bore until it seats squarely against the bore shoulder. A push tube made from a piece of plastic pipe would aid this installation. The I.D. of the pipe should be slightly larger than the O.D. of the shaft sleeve.

Slide the rotating portion of the seal (consisting of the integral shaft sleeve, spring centering washer, spring, bellows and retainer, and rotating element) onto the shaft until the seal faces contact.

Proceed with **Impeller Installation**

(Figure 2)

Inspect the impeller, and replace it if cracked or badly worn. Inspect the impeller and shaft threads for dirt or damage, and clean or dress the threads as required.



The shaft and impeller threads **must** be completely clean before reinstalling the impeller. Even the slightest amount of dirt on the threads can cause the impeller to seize to the shaft, making future removal difficult or impossible without damage to the impeller or shaft.

Apply anti-seize (G-R P/N 18685-031) to threads. Install and fully tighten impeller prior to installing impeller washer and capscrew.

NOTE

*At the slightest sign of binding, immediately back the impeller off, and check the threads for dirt. **Do not** try to force the impeller onto the shaft.*

Coat the threads of the impeller capscrew (27) with thread locker (G-R P/N 18771-109) and install the impeller Lockwasher (28) and capscrew; torque the capscrew to 90 ft. lbs. (1080 in. lbs. or 12,4 m. kg.).

Rotating Assembly Installation

(Figure 1)

NOTE

There is a 1-1/2 inch diameter socket head pipe plug (not shown) located in the side of the bearing housing. This hole is required for manufacturing purposes only; therefore the pipe plug should never require removal.

Install the bearing housing O-ring (5) and lubricate it with light grease. Ease the rotating assembly into the pump casing using the installation tool. **Be careful** not to damage the O-ring.

Install and secure the rotating assembly to the pump casing with the hardware (8 and 9).

Final Pump Assembly

(Figure 1)

Install the shaft key (24, Figure 2) and reconnect the power source. Be sure to install any guards used over the rotating members.



Do not operate the pump without the guards in place over the rotating parts. Exposed rotating parts can catch clothing, fingers, or tools, causing severe injury to personnel.

Install the suction and discharge lines (if removed) and open all valves. Make certain that all piping connections are tight, properly supported and secure.

Be sure the pump and power source have been properly lubricated, see **LUBRICATION**.

Refer to **OPERATION**, Section C, before putting the pump back into service.

LUBRICATION

Seal Assembly

(Figure 2)

Before starting the pump, remove the vented plug (11) and fill the seal cavity with SAE No. 30 non-detergent oil to the middle of the sight gauge (15) and maintain it at the middle of the gauge. Clean and reinstall the vented plug. Maintain the oil at this level.

NOTE

The white reflector in the sight gauge must be positioned horizontally to provide proper drainage.

Bearings

(Figure 2)

The bearing housing was fully lubricated when shipped from the factory. Check the oil level regularly through the sight gauge (15) and maintain it at the middle of the gauge. When lubrication is required, add SAE No. 30 non-detergent oil through the hole for the air vent (12). **Do not** over-lubricate. Over-lubrication can cause the bearings to over-heat, resulting in premature bearing failure.

NOTE

The white reflector in the sight gauge must be positioned horizontally to provide proper drainage.

Under normal conditions, drain the bearing housing once each year and refill with clean oil. Change the oil more frequently if the pump is operated con-

tinuously or installed in an environment with rapid temperature change.

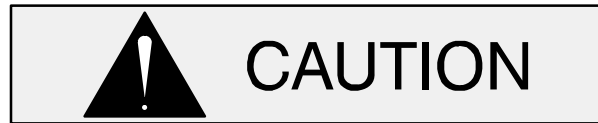

Monitor the condition of the bearing lubricant regularly for evidence of rust or moisture condensation. This is especially important in areas where variable hot and cold temperatures are common.

For cold weather operation, consult the factory or a lubricant supplier for the recommended grade of oil.

Power Source

Consult the literature supplied with the power source, or contact your local power source representative.

**For Warranty Information, Please Visit
www.grpumps.com/warranty
or call:
U.S.: 419-755-1280
Canada: 519-631-2870
International: +1-419-755-1352**

GORMAN-RUPP PUMPS