

**INSTALLATION, OPERATION,  
AND MAINTENANCE MANUAL**  
WITH PARTS LIST



6500 SERIES® PUMP

MODEL
<b>6504A31-B</b>

**GORMAN-RUPP PUMPS**

[www.grpumps.com](http://www.grpumps.com)

Register your new  
Gorman-Rupp pump online at  
**[www.grpumps.com](http://www.grpumps.com)**

Valid serial number and e-mail address required.

**RECORD YOUR PUMP MODEL AND SERIAL NUMBER**

Please record your pump model and serial number in the spaces provided below. Your Gorman-Rupp distributor needs this information when you require parts or service.

Pump Model: \_\_\_\_\_

Serial Number: \_\_\_\_\_

# TABLE OF CONTENTS

<b>INTRODUCTION</b> .....	<b>PAGE I – 1</b>
<b>SAFETY - SECTION A</b> .....	<b>PAGE A – 1</b>
<b>INSTALLATION – SECTION B</b> .....	<b>PAGE B – 1</b>
PREINSTALLATION INSPECTION .....	PAGE B – 1
POSITIONING PUMP .....	PAGE B – 1
Lifting .....	PAGE B – 1
Mounting .....	PAGE B – 2
SUCTION AND DISCHARGE PIPING .....	PAGE B – 2
Materials .....	PAGE B – 2
Line Configuration .....	PAGE B – 2
Connections to Pump .....	PAGE B – 2
Gauges .....	PAGE B – 2
SUCTION LINES .....	PAGE B – 2
Fittings .....	PAGE B – 2
Strainers .....	PAGE B – 2
Sealing .....	PAGE B – 2
Suction Lines In Sumps .....	PAGE B – 2
Suction Line Positioning .....	PAGE B – 3
DISCHARGE LINES .....	PAGE B – 4
Siphoning .....	PAGE B – 4
Valves .....	PAGE B – 4
ALIGNMENT .....	PAGE B – 4
Coupled Drives .....	PAGE B – 4
V-Belt Drives .....	PAGE B – 5
ELECTRICAL CONNECTIONS .....	PAGE B – 5
<b>OPERATION – SECTION C</b> .....	<b>PAGE C – 1</b>
PRIMING .....	PAGE C – 1
Hand Primers .....	PAGE C – 1
Exhaust Primers .....	PAGE C – 1
Auxiliary Ejectors .....	PAGE C – 2
Vacuum Pumps .....	PAGE C – 2
STARTING .....	PAGE C – 2
Rotation .....	PAGE C – 2
OPERATION .....	PAGE C – 2
Leakage .....	PAGE C – 2
Liquid Temperature And Overheating .....	PAGE C – 2
Strainer Check .....	PAGE C – 3
Pump Vacuum Check .....	PAGE C – 3
Operational Checks .....	PAGE C – 3
STOPPING .....	PAGE C – 3
Cold Weather Preservation .....	PAGE C – 4
BEARING TEMPERATURE CHECK .....	PAGE C – 4
LUBRICATION .....	PAGE C – 4
Power Source .....	PAGE C – 5

**TABLE OF CONTENTS**  
**(continued)**

<b>TROUBLESHOOTING – SECTION D .....</b>	<b>PAGE D – 1</b>
PREVENTIVE MAINTENANCE .....	PAGE D – 3
<b>PUMP MAINTENANCE AND REPAIR - SECTION E .....</b>	<b>PAGE E – 1</b>
STANDARD PERFORMANCE CURVE .....	PAGE E – 1
PARTS LIST:	
Pump End Assembly .....	PAGE E – 3
Repair Rotating Assembly .....	PAGE E – 5
PUMP AND SEAL DISASSEMBLY AND REASSEMBLY .....	PAGE E – 6
Suction Head and Wear Ring Removal .....	PAGE E – 7
Pump Casing Removal .....	PAGE E – 7
Draining Oil From Seal Cavity .....	PAGE E – 7
Impeller Removal .....	PAGE E – 7
Seal Removal .....	PAGE E – 8
Separating Rotating Assembly From Power Source .....	PAGE E – 8
Shaft and Bearing Removal And Disassembly .....	PAGE E – 8
Shaft and Bearing Reassembly and Installation .....	PAGE E – 9
Securing Rotating Assembly to Power Source .....	PAGE E – 10
Seal Reassembly and Installation .....	PAGE E – 10
Impeller Installation and Adjustment .....	PAGE E – 11
Pump Casing Installation .....	PAGE E – 12
Suction Head and Wear Ring Installation .....	PAGE E – 12
LUBRICATION .....	PAGE E – 12
Seal Assembly .....	PAGE E – 12
Bearings .....	PAGE E – 12

## INTRODUCTION

**Thank You** for purchasing a Gorman-Rupp pump. **Read this manual** carefully to learn how to safely install and operate your pump. Failure to do so could result in personal injury or damage to the pump.

Because pump installations are seldom identical, this manual cannot possibly provide detailed instructions and precautions for every aspect of each specific application. Therefore, it is the responsibility of the owner/installer of the pump to ensure that applications not addressed in this manual are performed **only** after establishing that neither operator safety nor pump integrity are compromised by the installation. Pumps and related equipment **must** be installed and operated according to all national, local and industry standards.

If there are any questions regarding the pump or its application which are not covered in this manual or in other literature accompanying this unit, please contact your Gorman-Rupp distributor, or The Gorman-Rupp Company:

**The Gorman-Rupp Company**  
**P.O. Box 1217**  
**Mansfield, Ohio 44901-1217**  
**Phone: (419) 755-1011**  
 or:  
**Gorman-Rupp of Canada Limited**  
**70 Burwell Road**  
**St. Thomas, Ontario N5P 3R7**  
**Phone: (519) 631-2870**

For information or technical assistance on the power source, contact the power source manufacturer's local dealer or representative.

## HAZARD AND INSTRUCTION DEFINITIONS

The following are used to alert maintenance personnel to procedures which require special attention, to those which could damage equipment, and to those which could be dangerous to personnel:



**Immediate hazards which WILL result in severe personal injury or death. These instructions describe the procedure required and the injury which will result from failure to follow the procedure.**



**Hazards or unsafe practices which COULD result in severe personal injury or death. These instructions describe the procedure required and the injury which could result from failure to follow the procedure.**



Hazards or unsafe practices which COULD result in minor personal injury or product or property damage. These instructions describe the requirements and the possible damage which could result from failure to follow the procedure.

### NOTE

*Instructions to aid in installation, operation, and maintenance or which clarify a procedure.*

## SAFETY - SECTION A

This information applies to 6500 Series® basic pumps. Gorman-Rupp has no control over or particular knowledge of the power source which will be used. Refer to the manual accompanying the power source before attempting to begin operation.

Because pump installations are seldom identical, this manual cannot possibly provide detailed instructions and precautions for each specific application. Therefore, it is the owner/installer's responsibility to ensure that applications not addressed in this manual are performed only after establishing that neither operator safety nor pump integrity are compromised by the installation.



Before attempting to open or service the pump:

1. Familiarize yourself with this manual.
2. Lock out or disconnect the power source to ensure that the pump will remain inoperative.
3. Allow the pump to completely cool if overheated.
4. Check the temperature before opening any covers, plates, or plugs.
5. Close the suction and discharge valves.
6. Vent the pump slowly and cautiously.
7. Drain the pump.



Death or serious personal injury and damage to the pump or components can occur if proper lifting procedures are not observed. Make certain that hoists, chains, slings or cables are in good working condition and of sufficient capacity and that they are positioned so that loads will be balanced and the pump or components will not be damaged when lifting. Suction and discharge hoses and piping must be removed from the pump before lifting. Lift the pump or component only as high as necessary and keep personnel away from suspended objects.



After the pump has been installed, make certain that the pump and all piping or hose connections are tight, properly supported and secure before operation.



Do not operate the pump without the shields and/or guards in place over the drive shaft, belts, and/or couplings, or other rotating parts. Exposed rotating parts can catch clothing, fingers, or tools, causing severe injury to personnel.



Do not operate the pump against a closed discharge valve for long periods of time. If operated against a closed dis-

charge valve, pump components will deteriorate, and the liquid could come to a boil, build pressure, and cause the pump casing to rupture or explode.



Overheated pumps can cause severe burns and injuries. If overheating of the pump occurs:

1. Stop the pump immediately.
2. Ventilate the area.
3. Allow the pump to completely cool.
4. Check the temperature before opening any covers, plates, gauges, or plugs.
5. Vent the pump slowly and cautiously.
6. Refer to instructions in this manual before restarting the pump.



Do not remove plates, covers, gauges, pipe plugs, or fittings from an overheated pump. Vapor pressure within the pump can cause parts being disengaged to be ejected with great force. Allow the pump to completely cool before servicing.



Never run this pump backwards. Be certain that rotation is correct before fully engaging the pump.



Pumps and related equipment must be installed and operated according to all national, local and industry standards.

## INSTALLATION – SECTION B

### Review all SAFETY information in Section A.

Since pump installations are seldom identical, this section offers only general recommendations and practices required to inspect, position, and arrange the pump and piping.

Most of the information pertains to a **flooded suction application** where the liquid is supplied to the pump under pressure. Since the pressure supplied to the pump is critical to performance and safety, **be sure** to limit the incoming pressure to

50% of the maximum permissible operating pressure as shown on the pump performance curve (see Section E, Page 1).

For further assistance, contact your Gorman-Rupp distributor or the Gorman-Rupp Company.

### Pump Dimensions

See Figure 1 for the approximate physical dimensions of this pump.

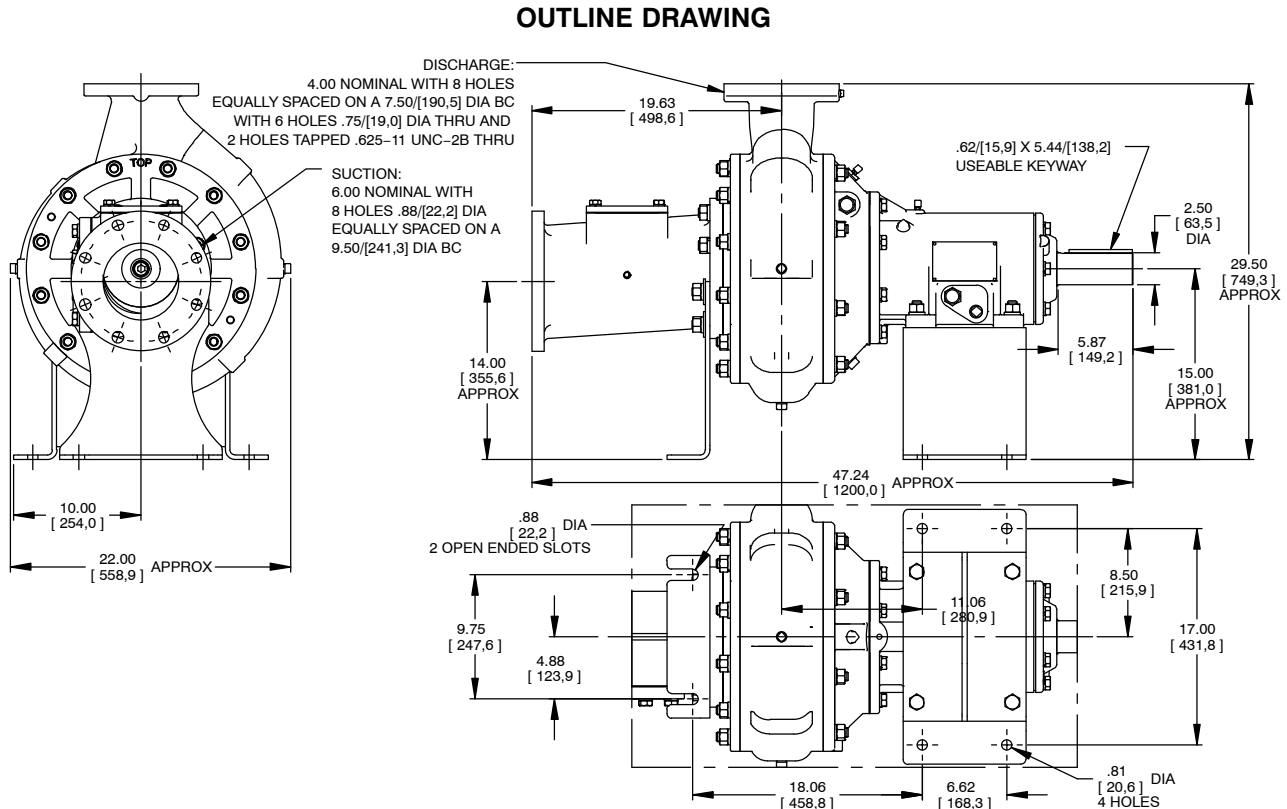

Figure 1. Pump Model 6504A31-B

### PREINSTALLATION INSPECTION

The pump assembly was inspected and tested before shipment from the factory. Before installation, inspect the pump for damage which may have occurred during shipment. Check as follows:

- a. Inspect the pump and engine for cracks, dents, damaged threads, and other obvious damage.

- b. Check for and tighten loose attaching hardware. Since gaskets tend to shrink after drying, check for loose hardware at mating surfaces.

- c. Carefully read all tags, decals, and markings on the pump assembly, and perform all duties indicated.

- d. Check levels and lubricate as necessary. Refer to **LUBRICATION** in the **MAINTENANCE**



**AND REPAIR** section of this manual and perform duties as instructed.

- e. If the pump has been stored for more than 12 months, some of the components or lubricants may have exceeded their maximum shelf life. These **must be inspected or replaced** to ensure maximum pump service.

If the maximum shelf life has been exceeded, or if anything appears to be abnormal, contact your Gorman-Rupp distributor or the factory to determine the repair or updating policy. **Do not** put the pump into service until appropriate action has been taken.

## POSITIONING PUMP



**Death or serious personal injury and damage to the pump or components can occur if proper lifting procedures are not observed. Make certain that hoists, chains, slings or cables are in good working condition and of sufficient capacity and that they are positioned so that loads will be balanced and the pump or components will not be damaged when lifting. Suction and discharge hoses and piping must be removed from the pump before lifting. Lift the pump or component only as high as necessary and keep personnel away from suspended objects.**

### Lifting

Pump unit weights will vary depending on the mounting and drive provided. Check the shipping tag on the unit packaging for the actual weight, and use lifting equipment with appropriate capacity. Drain the pump and remove all customer-installed equipment such as suction and discharge hoses or piping before attempting to lift existing, installed units.

### Mounting

Locate the pump in an accessible place as close as practical to the liquid being pumped. Level mounting is essential for proper operation.

Proper mounting of the pump, driver and base is critical to the performance of the pump. Improper mounting can result in vibration, which can cause damage to the pump and/or other system components.

The pumping unit must be securely mounted to a foundation that is heavy enough to absorb any vibration, strain or shock, while providing permanent, rigid support for the unit.

Because pump installations vary due to the specific application, this manual cannot possibly anticipate and provide detailed instructions for every installation. Therefore, it is recommended that the installer of the unit follow the recommendations provided by the Hydraulic Institute in their Rotodynamic Centrifugal Pump Design and Application manual when designing and fabricating the foundation upon which the pump, base and driver will be mounted.

## SUCTION AND DISCHARGE PIPING

The following is provided as general information for suction and discharge piping. Because pump installations vary due to the specific application, this manual cannot possibly anticipate and provide detailed instructions for every installation. Therefore, it is recommended that the installer follow the recommendations provided by the Hydraulic Institute in their Pump Piping for Rotodynamic Pumps manual for layout, design and installation of the system piping.

### Materials

Materials used in piping must be compatible with the liquid being pumped. Using piping couplings in suction lines is not recommended.

### Line Configuration

Keep suction and discharge lines as straight as possible to minimize friction losses. Make minimum use of elbows and fittings, which substantially increase friction loss. If elbows are necessary, use the long-radius type to minimize friction loss.

## Connections to Pump

Before tightening a connecting flange, align it exactly with the pump port. Never pull a pipe line into place by tightening the flange bolts and/or couplings.

Lines near the pump must be independently supported to avoid strain on the pump which could cause excessive vibration, decreased bearing life, and increased shaft and seal wear.

## Gauges

Most pumps are drilled and tapped for installing discharge pressure and vacuum suction gauges. If these gauges are desired for pumps that are not tapped, drill and tap the suction and discharge lines not less than 18 inches (457,2 mm) from the suction and discharge ports and install the lines. Installation closer to the pump may result in erratic readings.

## SUCTION LINES

To avoid air pockets which could affect pump priming, the suction line must be as short and direct as possible.

## Fittings

Suction lines should be the same size as the pump inlet. If reducers are used in suction lines, they should be the eccentric type, and should be installed with the flat part of the reducers uppermost to avoid creating air pockets. Valves are not normally used in suction lines, but if a valve is used for isolation purposes, install it with the stem horizontal to avoid air pockets.

## Strainers

A strainer or other device should be used to filter solids larger than the pump's capacity to avoid damage or decreased performance. Information about solids size handling can be found on the performance curve for your specific pump. When selecting or installing a strainer, make certain that the total area of the openings in the strainer is at least three or four times the cross section of the suction line, and the openings will not permit passage of

solids larger than the solids handling capability of the pump.

## Sealing

Since even a slight leak will affect pump performance, all connections in the suction line should be sealed with pipe dope to ensure an airtight seal. Follow the sealant manufacturer's recommendations when selecting and applying the pipe dope. The pipe dope should be compatible with the liquid being pumped.

## DISCHARGE LINES

### Siphoning

Do not terminate the discharge line at a level lower than that of the liquid being pumped unless a siphon breaker is used in the line. Otherwise, a siphoning action causing damage to the pump could result.

### Valves

If a throttling valve is desired in the discharge line, use a valve as large as the largest pipe to minimize friction losses. Never install a throttling valve in a suction line.

With high discharge heads, it is recommended that a throttling valve and a system check valve be installed in the discharge line to protect the pump from excessive shock pressure and reverse rotation when it is stopped.



If the application involves a high discharge head, gradually close the discharge throttling valve before stopping the pump.

## ALIGNMENT



This pump is designed for direct coupled drive only. Use of a V-belt drive will damage the pump and void the pump warranty.

The alignment of the pump and its power source is critical for trouble-free mechanical operation. The driver and pump must be mounted so that their shafts are aligned with and parallel to each other. It is imperative that alignment be checked after the pump and piping are installed, and before operation.

**NOTE**

Check **Rotation**, Section C, before final alignment of the pump.

When mounted at the Gorman-Rupp factory, driver and pump are aligned before shipment. Misalignment will occur in transit and handling. Pumps **must** be checked and realigned before operation. Before checking alignment, tighten the foundation bolts. The pump casing feet and/or pedestal feet, and the driver mounting bolts should also be tightly secured.



**When checking alignment, disconnect the power source to ensure that the pump will remain inoperative.**



Adjusting the alignment in one direction may alter the alignment in another direction. check each procedure after altering alignment.

**Coupled Drives**

When using couplings, the axis of the power source must be aligned to the axis of the pump shaft in both the horizontal and vertical planes. Most couplings require a specific gap or clearance between the driving and the driven shafts. Refer to the coupling manufacturer's service literature.

Align spider insert type couplings by using calipers to measure the dimensions on the circumference of the outer ends of the coupling hub every 90°. The coupling is in alignment when the hub ends

are the same distance apart at all points (see Figure 2A).

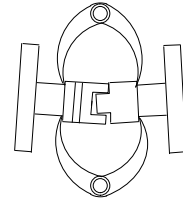

**Figure 2A. Aligning Spider-Type Couplings**

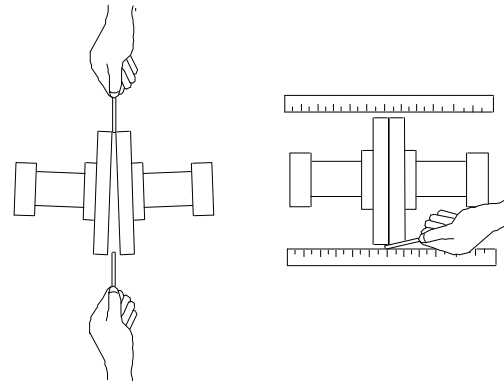

**Figure 2B. Aligning Non-Spider Type Couplings**

Align non-spider type couplings by using a feeler gauge or taper gauge between the coupling halves every 90°. The coupling is in alignment when the hubs are the same distance apart at all points (see Figure 2B).

Check parallel adjustment by laying a straightedge across both coupling rims at the top, bottom, and side. When the straightedge rests evenly on both halves of the coupling, the coupling is in horizontal parallel alignment. If the coupling is misaligned, use a feeler gauge between the coupling and the straightedge to measure the amount of misalignment.



**Do not operate the pump without the guard in place over the rotating parts. exposed rotating parts can catch clothing, fingers, or tools, causing severe injury to personnel.**

## OPERATION – SECTION C

Review all SAFETY information in Section A.

Follow the instructions on all tags, labels and decals attached to the pump.



This pump is designed to handle most non-volatile, non-flammable liquids containing specified entrained solids. Do not attempt to pump volatile, corrosive, or flammable liquids which may damage the pump or endanger personnel as a result of pump failure.

### STARTING

Consult the operations manual furnished with the power source.

### OPERATION

#### Leakage

No leakage should be visible at pump mating surfaces, or at pump connections or fittings. Keep all line connections and fittings tight to maintain maximum pump efficiency.

#### Liquid Temperature And Overheating

The **maximum** liquid temperature for this pump is 160°F (71°C). Do not apply it at a higher operating temperature.

Overheating can occur if operated with the valves in the suction or discharge lines closed. Operating against closed valves could bring the liquid to a boil, build pressure, and cause the pump to rupture or explode. If overheating occurs, stop the pump and allow it to cool before servicing it. Refill the pump casing with cool liquid.



**Allow an over-heated pump to cool before servicing. Do not remove plates, covers, gauges, or fittings from an over-heated pump. Liquid within the pump can reach boiling temperatures, and vapor pressure within the pump can cause parts being disengaged to be ejected with great force. After the pump cools, drain the liquid from the pump by removing the casing drain plug. Use caution when removing the plug to prevent injury to personnel from hot liquid.**

#### Strainer Check

If a suction strainer has been installed by the user, check the strainer regularly and clean it as necessary. The strainer should also be checked if pump flow rate begins to drop. If a vacuum suction gauge has been installed, monitor and record the readings regularly to detect strainer blockage.

**Never** introduce air or steam pressure into the pump casing or piping to remove a blockage. This could result in personal injury or damage to the equipment. If backflushing is absolutely necessary, **liquid pressure** must be limited to 50% of the maximum permissible operating pressure shown on the pump performance curve (see Section E, Page 1).

### STOPPING

If the liquid being pumped is stopped abruptly, damaging shock waves can be transmitted to the pump and piping system. Soft-start systems with ramp up/ramp down starting and stopping capabilities are available where water hammer may be a problem.

After stopping the pump, lock out or disconnect the power source to ensure that the pump will remain inoperative.

### **Cold Weather Preservation**

In below freezing conditions, drain the pump to prevent damage from freezing. Also, clean out any solids by flushing with a hose. Operate the pump for approximately one minute; this will remove any remaining liquid that could freeze the pump rotating parts. If the pump will be idle for more than a few hours, or if it has been pumping liquids containing a large amount of solids, drain the pump, and flush it thoroughly with clean water. To prevent large solids from clogging the drain port and preventing the pump from completely draining, insert a rod or stiff wire in the drain port, and agitate the liquid during the draining process. Clean out any remaining solids by flushing with a hose.

### **BEARING TEMPERATURE CHECK**

Bearings normally run at higher than ambient temperatures because of heat generated by friction.

Temperatures up to 160°F (71°C) are considered normal for bearings, and they can operate safely to at least 180°F (82°C).

Checking bearing temperatures by hand is inaccurate. Bearing temperatures can be measured accurately by placing a contact-type thermometer against the housing. Record this temperature for future reference.

A sudden increase in bearing temperatures is a warning that the bearings are at the point of failing to operate properly. Make certain that the bearing lubricant is of the proper viscosity and at the correct level (see **LUBRICATION** in Section E). Bearing overheating can also be caused by shaft misalignment and/or excessive vibration.

When pumps are first started, the bearings may seem to run at temperatures above normal. Continued operation should bring the temperatures down to normal levels.

## TROUBLESHOOTING – SECTION B

Review all SAFETY information in Section A.



**Before attempting to open or service the pump:**

- 1. Familiarize yourself with this manual.**
- 2. Lock out or disconnect the power source and take the necessary precautions to ensure that the pump will remain inoperative.**
- 3. Allow the pump to completely cool if overheated.**
- 4. Check the temperature before opening any covers, plates, or plugs.**
- 5. Close the suction and discharge valves.**
- 6. Vent the pump slowly and cautiously.**
- 7. Drain the pump.**

Table D-1 Troubleshooting Chart

TROUBLE	POSSIBLE CAUSE	PROBABLE REMEDY
<b>PUMP FAILS TO PRIME</b>	Auxiliary priming device faulty or improperly installed.  Discharge check valve open.  Air leak in suction line.  Lining of suction hose collapsed.  Leaking or worn seal or pump gasket.  Strainer clogged.	Repair priming device or check installation.  Check position of handle; close valve.  Correct leak.  Replace suction hose.  Check pump vacuum. Replace leaking or worn seal or gasket.  Check strainer and clean if necessary.
<b>PUMP STOPS OR FAILS TO DELIVER RATED FLOW OR PRESSURE</b>	Air leak in suction line.  Lining of suction hose collapsed.  Suction intake not submerged at proper level or sump too small.  Strainer clogged.	Correct leak.  Replace suction hose.  Check installation and correct submergence as needed.  Check strainer and clean if necessary.

Table D-1 Troubleshooting Chart (Continued)

TROUBLE	POSSIBLE CAUSE	PROBABLE REMEDY
<b>PUMP STOPS OR FAILS TO DELIVER RATED FLOW OR PRESSURE (cont.)</b>	<p>Impeller or other wearing parts worn or damaged.</p> <p>Leaking or worn seal or pump gasket.</p> <p>Impeller clogged.</p> <p>Pump running backwards (electric motor driven models).</p> <p>Suction lift or discharge head too high.</p> <p>Liquid solution too thick.</p>	<p>Replace worn or damaged parts. Check that impeller is properly centered and rotates freely.</p> <p>Check pump vacuum. Replace leaking or worn seal or gasket.</p> <p>Free impeller of debris.</p> <p>Check direction of rotation. Correct 3-phase wiring by interchanging any two motor leads at control box. (See <b>Pump Rotation</b> in the Installation and Operations Manual.)</p> <p>Check piping installation and install bypass line if needed. See <b>INSTALLATION</b> in the Installation and Operations manual.</p> <p>Dilute if possible.</p>
<b>PUMP REQUIRES TOO MUCH POWER</b>	<p>Pump speed too high.</p> <p>Discharge head too low.</p> <p>Liquid solution too thick.</p> <p>Impeller jammed due to debris or insufficient clearance.</p>	<p>Check governor setting (engine driven models).</p> <p>Adjust discharge valve.</p> <p>Dilute if possible.</p> <p>Disassemble pump and check impeller.</p>
<b>PUMP CLOGS FREQUENTLY</b>	<p>Discharge flow too slow.</p> <p>Suction check valve or foot valve clogged or binding.</p>	<p>Open discharge valve fully to increase flow rate, and run power source at maximum governed speed.</p> <p>Clean valve.</p>
<b>EXCESSIVE NOISE</b>	<p>Cavitation in pump.</p> <p>Pumping entrained air.</p> <p>Pump or drive not securely mounted.</p> <p>Impeller clogged or damaged.</p>	<p>Reduce suction lift and/or friction losses in suction line. Record vacuum and pressure gauge readings and consult local representative or factory.</p> <p>Locate and eliminate source of air bubble.</p> <p>Secure mounting hardware.</p> <p>Clean out debris; replace damaged parts.</p>

Table D-1 Troubleshooting Chart (Continued)

TROUBLE	POSSIBLE CAUSE	PROBABLE REMEDY
<b>BEARINGS RUN TOO HOT</b>	Bearing temperature is high, but within limits.	Check bearing temperature regularly to monitor any increase
	Low or incorrect lubricant.	Check for proper type and level of lubricant.

## PREVENTIVE MAINTENANCE

Since pump applications are seldom identical, and pump wear is directly affected by such things as the abrasive qualities, pressure and temperature of the liquid being pumped, this section is intended only to provide general recommendations and practices for preventive maintenance. Regardless of the application however, following a routine preventive maintenance schedule will help assure trouble-free performance and long life from your Gorman-Rupp pump. For specific questions concerning your application, contact your Gorman-Rupp distributor or the Gorman-Rupp Company.

Record keeping is an essential component of a good preventive maintenance program. Changes in suction and discharge gauge readings (if so

equipped) between regularly scheduled inspections can indicate problems that can be corrected before system damage or catastrophic failure occurs. The appearance of wearing parts should also be documented at each inspection for comparison as well. Also, if records indicate that a certain part (such as the seal) fails at approximately the same duty cycle, the part can be checked and replaced before failure occurs, reducing unscheduled down time.

For new applications, a first inspection of wearing parts at 250 hours will give insight into the wear rate for your particular application. Subsequent inspections should be performed at the intervals shown on the chart below. Critical applications should be inspected more frequently.



<b>Preventive Maintenance Schedule</b>					
Item	Service Interval*				
	Daily	Weekly	Monthly	Semi-Annually	Annually
General Condition (Temperature, Unusual Noises or Vibrations, Cracks, Leaks, Loose Hardware, Etc.)	I				
Pump Performance (Gauges, Speed, Flow)	I				
Bearing Lubrication		I			R
Seal Lubrication (And Packing Adjustment, If So Equipped)		I			R
V-Belts (If So Equipped)			I		
Air Release Valve Plunger Rod (If So Equipped)			I	C	
Front Impeller Clearance (Wear Plate)				I	
Rear Impeller Clearance (Seal Plate)				I	
Check Valve					I
Pressure Relief Valve (If So Equipped)					C
Pump and Driver Alignment					I
Shaft Deflection					I
Bearings					I
Bearing Housing					I
Piping					I
Driver Lubrication – See Mfgr’s Literature					I

Legend:  
 I = Inspect, Clean, Adjust, Repair or Replace as Necessary  
 C = Clean  
 R = Replace

\* Service interval based on an intermittent duty cycle equal to approximately 4000 hours annually. Adjust schedule as required for lower or higher duty cycles or extreme operating conditions.

## PUMP MAINTENANCE AND REPAIR - SECTION E

MAINTENANCE AND REPAIR OF THE WEARING PARTS OF THE PUMP WILL MAINTAIN PEAK OPERATING PERFORMANCE.

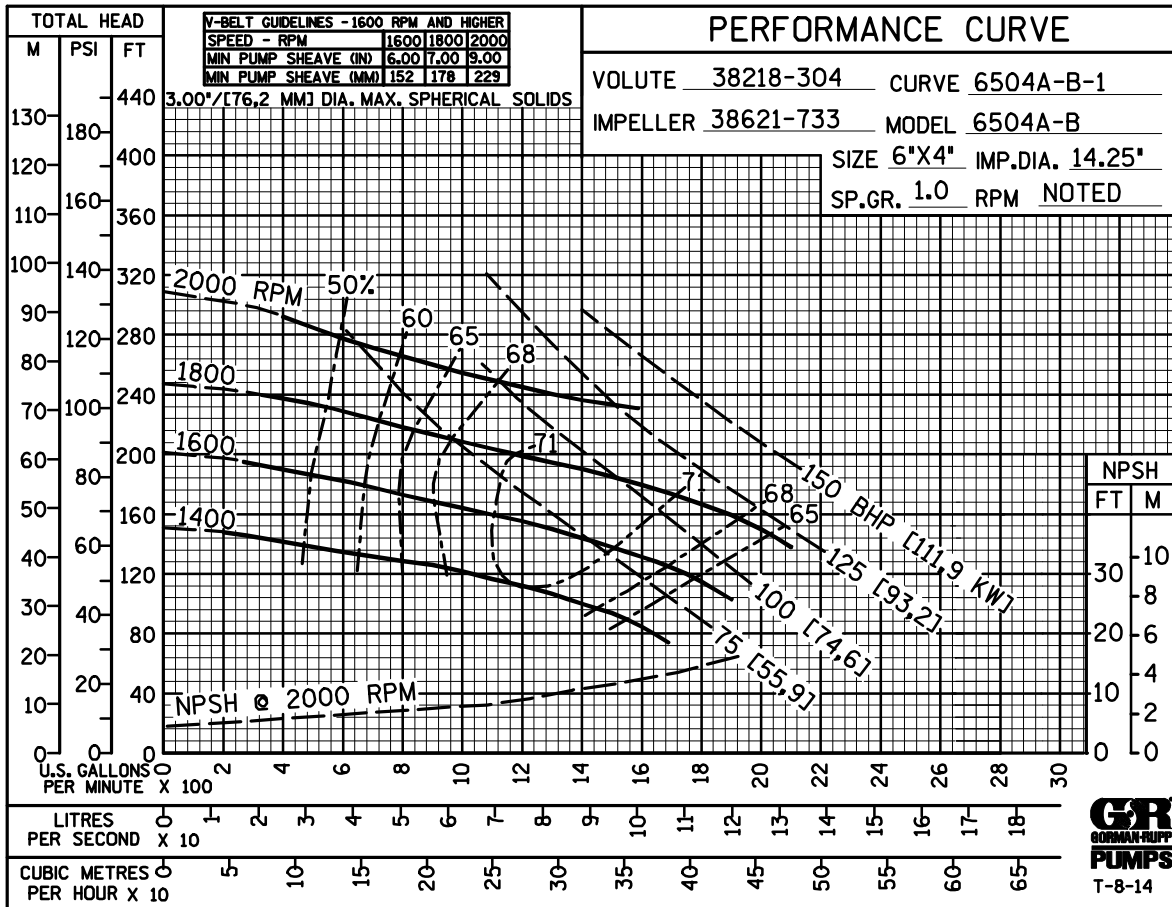

**\* STANDARD PERFORMANCES FOR PUMP MODEL 6504A31-B**

\* Based on 70°F (21°C) clear water at sea level with minimum suction lift. Since pump installations are seldom identical, your performance may be difference due to such factors as viscosity, specific gravity, elevation, temperature, and impeller trim.

Contact the Gorman-Rupp Company to verify performance or part numbers.



If your pump serial number is followed by an "N", your pump is **NOT** a standard production model.

Pump speed and operating condition points must be within the continuous performance range shown on the curve.

ILLUSTRATION

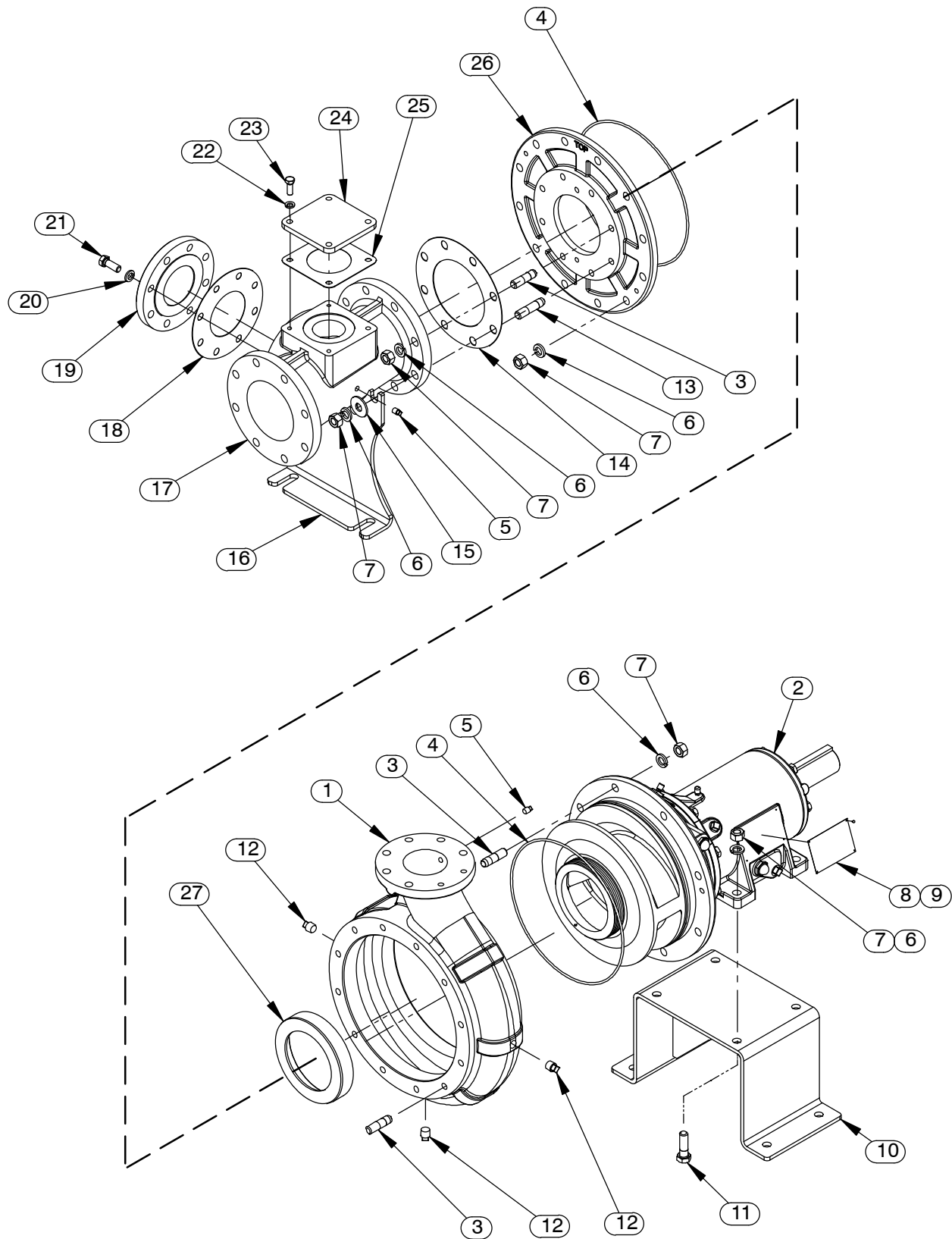

Figure 1. Pump Assembly 6504A31-B

**PARTS LIST**  
**Pump Assembly 6504A31-B**  
 (From S/N 1840766 Up)

If your pump serial number is followed by an "N", your pump is **NOT** a standard production model. Contact the Gorman-Rupp Company to verify part numbers.

ITEM NO.	PART NAME	PART NUMBER	QTY
☞ 1	PUMP CASING	SEE NOTE BELOW	1
2	REPAIR ROTATING ASSEMBLY	44163-862	1
☞ 3	STUD	C1211 15991	24
4	* O-RING	25152-383	2
☞ 5	PIPE PLUG	P04 15079	2
6	LOCK WASHER	J12 15991	32
7	HEX NUT	D12 15991	32
8	NAMEPLATE BLANK	38819-002 13000	1
9	DRIVE SCREW	BM#04-03 17000	4
10	BEARING STAND	41583-241 24150	1
11	HEX HEAD CAP SCREW	B1210 15991	4
☞ 12	PIPE PLUG	P08 15079	3
13	STUD	C1213 15991	4
14	* GASKET	25113-036	1
15	FLAT WASHER	K12 15991	4
16	STAND	34265-067 15080	1
17	6" SUCTION SPOOL	38644-814 11010	1
18	* GASKET	25113-034	1
19	4" BLIND FLANGE ASSEMBLY	42111-463	1
20	LOCK WASHER	J10 15991	8
21	HEX HEAD CAP SCREW	B1007 15991	8
22	LOCK WASHER	J08 15991	4
23	HEX HEAD CAP SCREW	B0805-1/2 15991	4
24	COVER PLATE	33541-045 15080	1
25	* GASKET	38687-053 19060	1
26	SUCTION HEAD	38246-627 11010	1
27	* WEAR RING	38691-374 11010	1
NOT SHOWN:			
	SUCTION STICKER	6588AG	1
	DISCHARGE STICKER	6588BJ	1
	ROTATION DECAL	2613M	1
	G-R DECAL 6 IN	GR-06	1
	WARNING DECAL	2613FE	1
	INSTRUCTION TAG	38817-104	1
	INSTRUCTION TAG	38817-011	1
☞	INCLUDED W/REPAIR PUMP CASING ASSY	46474-364	1

\* INDICATES PARTS RECOMMENDED FOR STOCK

ILLUSTRATION

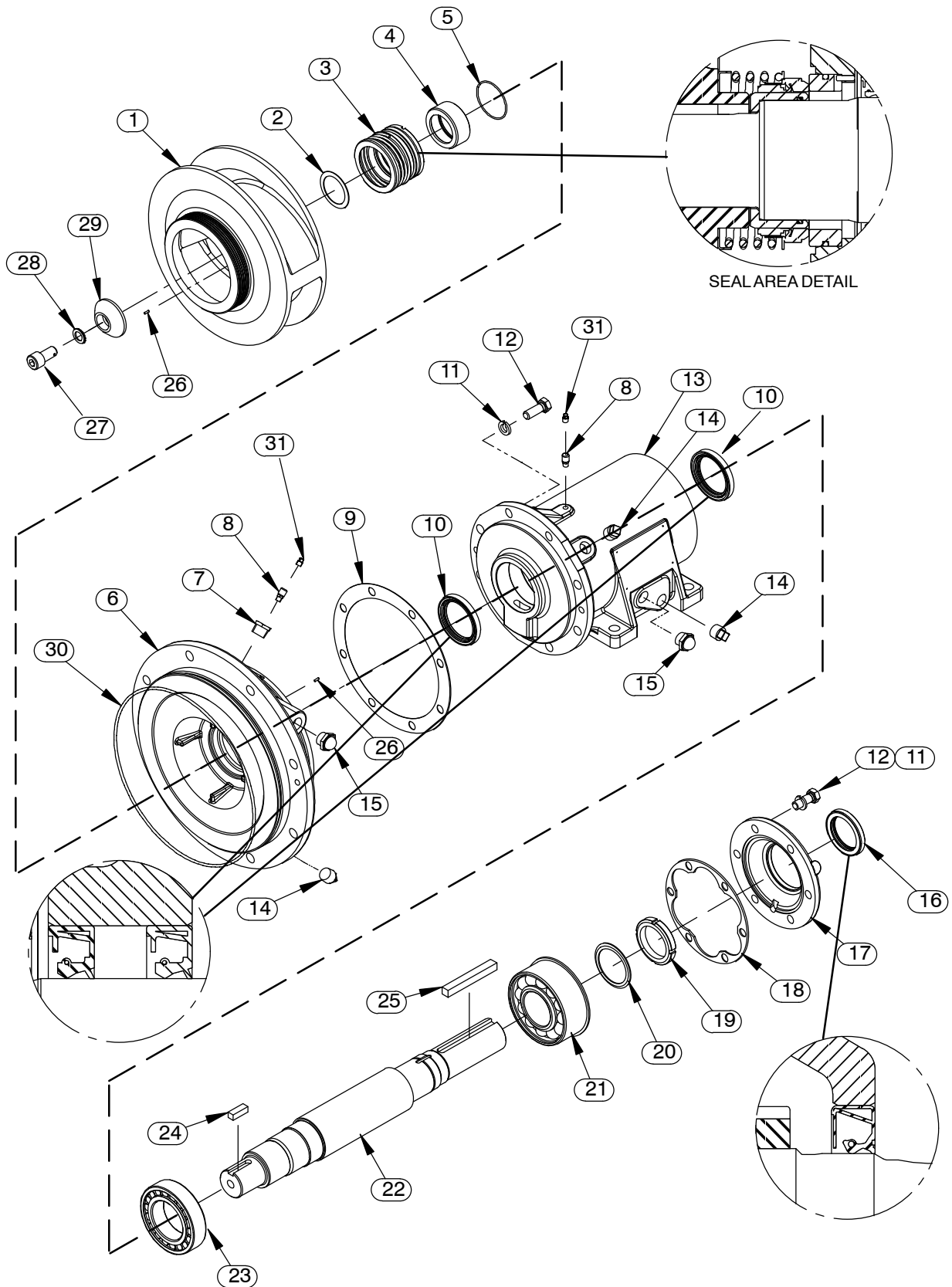

Figure 2. Repair Rotating Assembly

**PARTS LIST**  
**Repair Rotating Assembly**

ITEM NO.	PART NAME	PART NUMBER	QTY
1	IMPELLER	38621-733 11010	1
2	* SHIM SET	48261-033	1
3	* 3.25" MECH SEAL	25285-822	1
4	* SHAFT SLEEVE	31163-022 17000	1
5	* O-RING	25152-150	1
6	SEAL PLATE	38272-533 11010	1
7	REDUCER PIPE BUSHING	AP1202 15079	1
8	AIR VENT	S1530	2
9	* GASKET	38683-665 19370	1
10	* LIP SEAL	25227-856	2
11	LOCK WASHER	J10 15991	14
12	HEX HEAD CAP SCREW	B1007 15991	14
13	PEDESTAL	38257-210 10000	1
14	PIPE PLUG	P12 15079	5
15	SIGHT GAUGE	S1471	4
16	* OIL SEAL	25258-845	1
17	BEARING CAP	38322-434 10000	1
18	* BEARING CAP GASKET	38683-664 19060	1
19	BEARING LOCKNUT	23962-015	1
20	LOCKING TAB COLLAR	23962-515	1
21	* BEARING	23422-417	1
22	IMPELLER SHAFT	38512-545 1600X	1
23	* ROLLER BEARING	23535-001	1
24	* KEY	N0806 15990	1
25	* KEY	N1020 15990	1
26	ROLL PIN	S2197	2
27	SOCKET HEAD CAP SCREW	DM1206 15991	1
28	WASHER NORD-LOCK 3/4"	21177-224	1
29	IMPELLER WASHER	31167-042 17000	1
30	* O-RING	25152-383	1
31	SHIPPING PLUG	11495C 15079	2
NOT SHOWN:			
	INSTRUCTION TAG	6588U	1
	OIL LEVEL DECAL	38816-123	1
	LUBRICATION DECAL	11421A	1

\* INDICATES PARTS RECOMMENDED FOR STOCK

## PUMP AND SEAL DISASSEMBLY AND REASSEMBLY

Review all SAFETY information in Section A.

Follow the instructions on all tags, label and decals attached to the pump.

This pump requires little service due to its rugged, minimum-maintenance design. However, if it becomes necessary to inspect or replace the wearing parts, follow these instructions which are keyed to the illustrations (see Figures 1 and 2) and the corresponding Parts Lists.

Some pump service functions may be performed without separating the pump end assembly from the power source. However, the following instructions assume complete disassembly of the pump is required.

Before attempting to service the pump, shut down the power source and take precautions to ensure that it will remain inoperative. Close all valves in the suction and discharge lines and drain the pump casing by removing the lowermost pipe plug (12, Figure 1). Clean and reinstall the pipe plug.



This manual will alert personnel to known procedures which require special attention, to those which could damage equipment, and to those which could be dangerous to personnel. However, this manual cannot possibly anticipate and provide detailed instructions and precautions for every situation that might occur during maintenance of the unit. Therefore, it is the responsibility of the owner/maintenance personnel to ensure that only safe, established maintenance procedures are used, and that any procedures not addressed in this manual are performed only after establishing that neither personal safety nor pump integrity are compromised by such practices.



Before attempting to open or service the pump:

1. Familiarize yourself with this manual.
2. Shut down the power source and take precautions to ensure that the pump will remain inoperative.
3. Allow the pump to completely cool if overheated.
4. Check the temperature and make sure it is cool before opening any covers, plates, gauges, or plugs.
5. Close the suction and discharge valves.
6. Vent the pump slowly and cautiously.
7. Drain the pump.



Death or serious personal injury and damage to the pump or components can occur if proper lifting procedures are not observed. Make certain that hoists, chains, slings or cables are in good working condition and of sufficient capacity and that they are positioned so that loads will be balanced and the pump or components will not be damaged when lifting. Suction and discharge hoses and piping must be removed from the pump before lifting. Lift the pump or component only as high as necessary and keep personnel away from suspended objects.



Use **Only Genuine Gorman–Rupp** replacement parts. Failure to do so may create a hazard and damage the pump or diminish optimal pump performance. Any such hazard, damage or diminished performance is not covered by the warranty.

### NOTE

*When appropriate recycling facilities are available, the user should recycle components and fluids when doing any routine maintenance / repairs and also at the end of the pump's useful life. All other components and fluids shall be disposed of according to all applicable codes and regulations.*

### Suction Head and Wear Ring Removal

#### (Figure 1)

The wear ring (27) is easily accessible and may be serviced by removing the suction head (26). Before attempting to service the pump, remove the lowermost pipe plug (12) from the pump casing (1) and drain the pump. Clean and reinstall the drain plug.

It is not necessary to remove the suction spool (17) from the suction head unless replacement of the spool, gasket (14) or suction head is required. To remove the suction spool, disengage the hardware (6, 7 and 15) securing it to the pump casing. Remove the gasket (14).

Remove the hardware (6 and 7) securing the suction head to the pump casing. Install two 5/8–11 UNC-2B capscrews (not supplied) in the tapped holes in the suction head and use the capscrews to press the suction head out of the pump casing. Remove the capscrews from the suction head.

Remove and discard the O-ring (4).

Inspect the wear ring and, if replacement is required, install two 3/4–10 UNC-2B capscrews (not supplied) in the tapped holes in the suction head and use the screws to press the wear ring out of the suction head. Remove the capscrews from the suction head.

### Pump Casing Removal

#### (Figure 1)

Remove the uppermost pipe plug (12) from the pump casing and install a lifting eye in the hole. Be sure to screw the lifting eye tightly into the hole as far as it will go. Attach a sling and suitable lifting device to the lifting eye and support the pump casing.

Remove the hardware (6 and 7) and use the lifting device to pull the pump casing straight away from the rotating assembly (2). **Use caution** to ensure that the pump casing does not fall onto and damage the impeller.

Remove and discard the pump casing O-ring (4).

### Draining Oil From Seal Cavity

#### (Figure 2)

If any further disassembly is to be performed on the pump, the seal oil cavity must be drained to prevent the oil in the seal cavity from escaping as the pump casing is removed.

Position a **clean** container under the seal cavity drain plug (14). Remove the plug and drain the oil from the seal cavity into the container. For shorter drain time, remove one of the pipe plugs (14). Clean and reinstall the drain plug and pipe plug. Inspect the oil for water, dirt or a cloudy condition which could indicate seal failure.

### Impeller Removal

#### (Figure 2)

With the pump casing removed, use an impact wrench with a hex key to loosen the impeller capcrew (27). Remove the capcrew, impeller washers (28 and 29) and roll pin (26).

Use a suitable three-jawed puller to remove the impeller (1) and key (24) from the shaft (22). Use caution when removing the impeller; tension on the shaft seal spring will be released as the impeller is removed.

### NOTE

*An alternate method of removing the impeller is to insert a pair of wedges 180° apart between the impeller and seal plate (6). Tap the wedges evenly in an alternating pattern to "walk" the impeller off the*



*shaft.*

Remove the impeller adjusting shims (2); tie and tag the shims, or measure and record their thickness for ease of reassembly.

Inspect the impeller and replace if cracked or badly worn.

### Seal Removal

#### (Figures 2 and 3)

Remove the spring centering washer and seal spring. Slide the shaft sleeve (4) and rotating portion of the seal off the shaft as a unit.

Apply oil to the shaft sleeve and work it up under the rubber bellows. Slide the rotating portion of the seal off the shaft sleeve. Remove the shaft sleeve O-ring (5).

Use a pair of stiff wires with hooked ends to remove the stationary element from the seal plate bore.

An alternate method of removing the stationary seal components is to remove the hardware (11 and 12) and separate the seal plate and gasket (9) from the pedestal (13). Position the seal plate on a flat surface with the impeller side down. Use a wooden dowel or other suitable tool to press on the back side of the stationary element until the element and its O-ring can be removed.

If no further disassembly is required, refer to **Seal Installation**.

### Separating Rotating Assembly From Power Source

#### (Figure 1)

Further disassembly requires separating the rotating assembly from the power source. Remove the coupling securing the rotating assembly to the power source and remove the key (25, Figure 2).

Remove any hardware (6, 7 and 11) securing the rotating assembly to the bearing stand (10) and use a suitable hoist and sling to move the rotating assembly to a clean, well-equipped workshop for further disassembly.

### Shaft and Bearing Removal and Disassembly

#### (Figure 2)

When the pump is properly operated and maintained, the pedestal (13) should not require disassembly. Disassemble the shaft and bearings **only** when there is evidence of wear or damage.

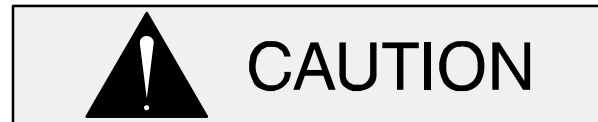

Shaft and bearing disassembly in the field is not recommended. These operations should be performed only in a properly equipped shop by qualified personnel.

Remove the pedestal drain plug (14) and drain the lubricant. Clean and reinstall the drain plug. For shorter drain time, remove the air vent (8). Clean and reinstall the drain plug and air vent after draining.

If not removed with the seal assembly, remove the hardware (11 and 12) and separate the seal plate (6) and gasket (9) from the pedestal.

Disengage the hardware (11 and 12) and remove the bearing cap (17), gasket (18) and oil seal (16). Press the oil seal from the bearing cap.

Place a block of wood against the impeller end of the shaft (22) and tap the shaft and assembled bearings (21 and 23) from the pedestal.

Press the oil seals (10) from the pedestal.

After removing the shaft and bearings, clean and inspect the bearings **in place** as follows.



To prevent damage during removal from the shaft, it is recommended that bearings be cleaned and inspected **in place**. It is **strongly** recommended that the bearings be replaced **any** time the shaft and bearings are removed.

Clean the pedestal, shaft and all component parts (except the bearings) with a soft cloth soaked in cleaning solvent. Inspect the parts for wear or damage and replace as necessary.



**Most cleaning solvents are toxic and flammable. Use them only in a well ventilated area free from excessive heat, sparks, and flame. Read and follow all precautions printed on solvent containers.**

Clean the bearings thoroughly in **fresh** cleaning solvent. Dry the bearings with filtered compressed air and coat with light oil.

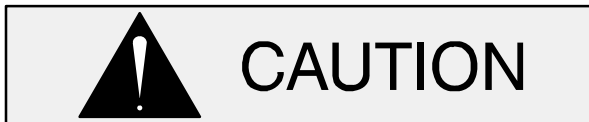

Bearings must be kept free of all dirt and foreign material. Failure to do so will greatly shorten bearing life. **Do not** spin dry bearings. This may scratch the balls or races and cause premature bearing failure.

Rotate the bearings by hand to check for roughness or binding and inspect the bearing rollers and balls. If rotation is rough or the rollers or bearing balls are discolored, replace the bearings.

The bearing tolerances provide a tight press fit onto the shaft and a snug slip fit into the pedestal. Replace the bearings, shaft, or pedestal if the proper bearing fit is not achieved.

If bearing replacement is required, straighten the tab on the bearing lock washer (20). Use a spanner wrench to remove the bearing lock nut (19). Remove the bearing lock washer.

Use a bearing puller to remove the inboard and outboard bearings from the shaft.

### **Shaft and Bearing Reassembly and Installation (Figure 2)**

Inspect the shaft (22) for distortion, nicks or scratches, or for thread damage on the impeller end. Dress small nicks and burrs with a fine file or emery cloth. Replace the shaft if defective.

Clean and inspect the bearings as indicated in **Shaft And Bearing Removal And Disassembly**.



To prevent damage during removal from the shaft, it is recommended that bearings be cleaned and inspected **in place**. It is **strongly** recommended that the bearings be replaced **any** time the shaft and bearings are removed.

The bearings may be heated to ease installation. An induction heater, hot oil bath, electric oven, or hot plate may be used to heat the bearings. Bearings should **never** be heated with a direct flame or directly on a hot plate.

#### **NOTE**

*If a hot oil bath is used to heat the bearings, both the oil and the container must be **absolutely** clean. If the oil has been previously used, it must be **thoroughly** filtered.*

#### **NOTE**

*Position the outboard bearing (21) on the shaft with the retaining ring on the bearing O.D. **toward the drive end of the shaft**.*

Heat the bearings to a uniform temperature **no higher than 250° F (120° C)** and slide the bearings onto the shaft, one at a time, until they are fully seated against the shaft shoulders. This should be done quickly, in one continuous motion, to prevent the bearings from cooling and sticking on the shaft.

After the bearings have been installed and allowed to cool, check to ensure that they have not moved during cooling. If movement has occurred, use a suitably sized sleeve and a press to reposition the bearings against the shaft shoulders.

If heating the bearings is not practical, use a suitably sized sleeve and an arbor (or hydraulic) press to install the bearings on the shaft.



When installing the bearings onto the shaft, **never** press or hit against the outer race, balls, rollers or cage. Press **only** on the inner race.

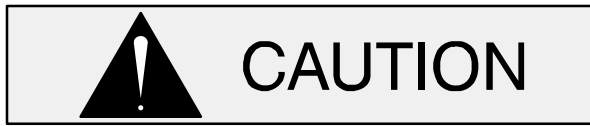

It is recommended that a new bearing lock washer (20) be installed any time the shaft and bearings are disassembled. Re-use of an old lock washer may create a pre-load condition on the bearing, resulting in premature bearing failure.

Install the bearing lockwasher (20) and screw the bearing locknut (19) onto the shaft until tight. Torque the bearing lock nut to (150 ft. lbs. (20,8 m. kg.)). After torquing, locate the tab on the lock washer that aligns with a slot in the lock nut and bend the tab over into the slot.

Apply a light coating of oil to the lip of the inboard oil seal (10) and press it into the pedestal bore with the lip positioned as shown in Figure 2. Press the oil seal into the pedestal until the face is **just flush** with the machined surface on the inside of the pedestal.

It is recommended that a sleeve be positioned against the inboard oil seal to prevent the lip of the oil seal from rolling as the shaft and bearings are installed in the pedestal. The O.D. of the sleeve should be just smaller than the pedestal bore, while the I.D. of the sleeve should be just larger than the O.D. of the oil seal area of the shaft.

With the oil seal sleeve in place, lubricate the oil seal area of the shaft and slide the shaft and assembled bearings into the pedestal until the retaining ring on the outboard bearing seats against the pedestal. Remove the oil seal sleeve.



When installing the shaft and bearings into the bearing bore, push against the outer race. **Never** hit the balls, rollers or cages.

Apply a light coating of oil to the lip of the outboard oil seal (10) and press it into the pedestal with the lip positioned as shown in Figure 2. The face of the oil seal should be **just flush** with the outer face of the pedestal.

Apply a light coating of oil to the lip of the oil seal (16) and press it into the bearing cap (17) with the lip positioned as shown in Figure 2. The oil seal should be centered in the bearing cap bore.

Install the gasket (18) and slide the assembled bearing cap and oil seal over the impeller shaft. Use caution not to cut or roll the lip of the oil seal (16) on the shaft keyway. Secure the bearing cap to the pedestal with the hardware (11 and 12). Torque the capscrews (12) to 41 ft. lbs. (5,7 m. kg.).

Lubricate the bearings as indicated in **LUBRICATION** at the end of this section.

### Securing Rotating Assembly to Power Source

(Figure 1)

Install the drive key (25, Figure 2) in the shaft keyway.

Reinstall the drive coupling on the impeller shaft. Using a suitable lifting device, position the rotating assembly on the bearing stand (10) and secure it with the previously removed hardware (6, 7 and 11). Align the coupling as described in **Installation, Section B**.

### Seal Reassembly and Installation

(Figures 2 and 3)



**Most cleaning solvents are toxic and flammable. Use them only in a well ventilated area free from excessive heat, sparks, and flame. Read and follow all precautions printed on solvent containers.**

Clean the seal cavity and shaft with a cloth soaked in fresh cleaning solvent. Inspect the stationary seat bore in the seal plate for dirt, nicks and burrs, and remove any that exist. The stationary seat bore **must** be completely clean before installing the seal.



A new seal assembly should be installed

**any time** the old seal is removed from the pump. Wear patterns on the finished faces cannot be realigned during reassembly. Reusing an old seal could result in premature failure.

To ease installation of the seal, lubricate the shaft sleeve O-ring and the stationary element O-ring with "P-80<sup>®</sup> Emulsion" or water. **Do not** use oil or any substitute lubricant other than water. See Figure 3 for seal part identification.

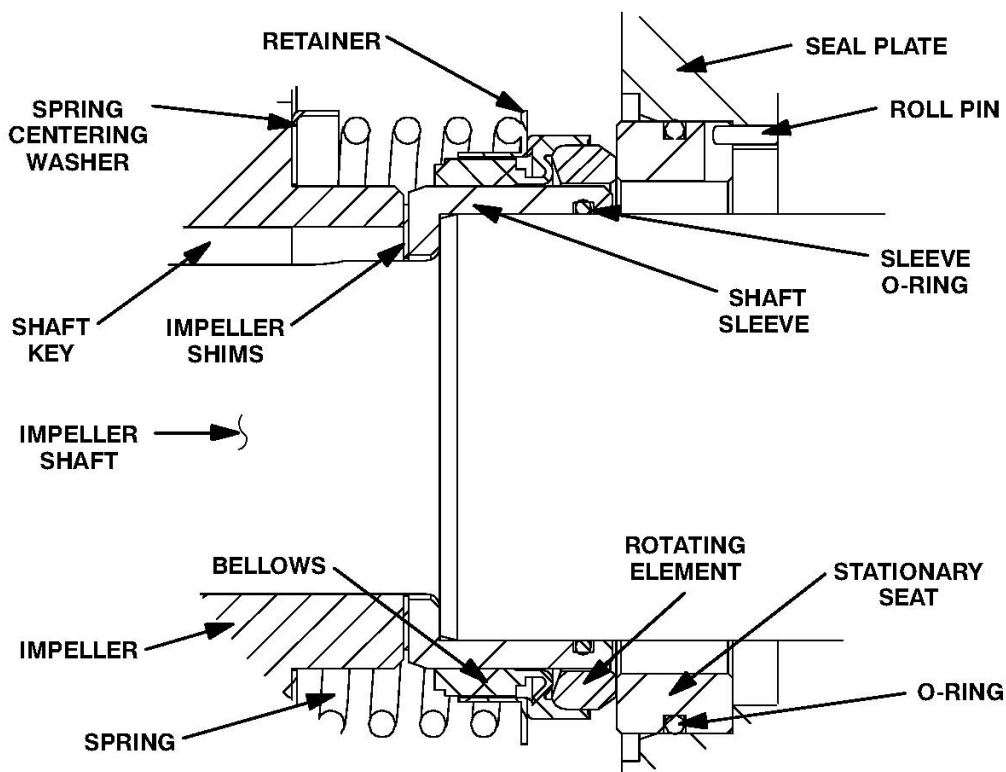

Figure 3. Seal Assembly



This seal is not designed for operation at temperatures above 160°F (71°C). Do not use at higher operating temperatures.

If the seal plate was removed, install the seal plate gasket (9), position the seal plate over the shaft and secure it to the pedestal with the hardware (11 and 12).

If a new seal plate is being installed, position the roll pin (26) in the hole in the seal plate bore and tap it into place with a hammer until fully seated.

Align the notch in the stationary seal seat with the roll pin (26) and press the stationary seat and its O-ring into the seal plate until fully seated in the seal plate bore.

A push tube cut from a length of plastic pipe would aid this process. The I.D. of the tube should be slightly larger than the O.D. of the shaft sleeve (4).

Install the shaft sleeve O-ring (5) in the groove in the I.D. of the sleeve. Lubricate the O-ring and the O.D. of the shaft sleeve with "P-80<sup>®</sup> Emulsion" or water. **Do not** use oil or any substitute lubricant other than water.

Slide the rotating subassembly (consisting of the rotating element, retainer and bellows) onto the sleeve until the rotating element is **just flush** with the chamfered end of the sleeve. Slide the shaft sleeve and rotating subassembly onto the shaft until the seal faces contact and the shaft sleeve seats against the shoulder on the impeller shaft. Install the seal spring and spring centering washer.

Lubricate the seal assembly as indicated in **LUBRICATION**, after the impeller has been installed.

### Impeller Installation and Adjustment (Figure 2)

Inspect the impeller (1) and replace it if cracked or badly worn.

Install the same thickness of adjusting shims (2) as previously installed. Install the impeller key (24) in the shaft keyway. Align the keyway in the impeller with the shaft key and press the impeller onto the shaft until fully seated.

A clearance of .025 to .040 inch (0,64 to 1,02 mm) between the impeller and the seal plate is necessary for maximum pump efficiency. Measure this clearance and add or remove impeller adjusting shims as required.

Apply 'Loctite Retaining Compound No. 242' or equivalent to the threads of the impeller capscrew (27). Install the roll pin (26) in the hole in the impeller. Position the impeller washers (28 and 29) over the end of the impeller shaft so the hole in the washer aligns with the roll pin. Use a strap wrench to block impeller rotation and torque the impeller capscrew to 180 ft. lbs. (24,9 m. kg.).

### Pump Casing Installation

#### (Figure 1)

Lubricate the O-ring (4) with light grease and install it in the groove in the O.D. of the seal plate (6, Figure 2). Install a lifting eye in the uppermost hole in the pump casing (1) for the pipe plug (12). Be sure to screw the lifting eye tightly into the hole as far as it will go. Attach a sling and suitable lifting device to the lifting eye and use the lifting device to position the pump casing over the rotating assembly. Install the hardware (6 and 7) on the studs (3) and use the hardware to fully seat the pump casing against the seal plate. Remove the lifting eye and reinstall the pipe plug.

### Suction Head and Wear Ring Installation

#### (Figure 1)

If the wear ring (27) was removed, position the replacement wear ring in the suction head (26) and use an arbor (or hydraulic) press to press it into the suction head until fully seated.

Install the O-ring (4) in the groove in the O.D. of the suction head and lubricate it with light grease. Position the suction head over the studs (4) and use the hardware (6 and 7) to fully seat the suction head in the pump casing.

If the suction spool (17) was removed, install a new gasket (14) and secure the spool to the suction

head with the previously removed hardware (6, 7 and 15).

## LUBRICATION

### (Figure 2)

#### Seal Assembly

Before starting the pump, remove the air vent (8) and fill the seal cavity with approximately 5 quarts (4,7 liters) of SAE No. 30 non-detergent oil or to the center of the sight gauges (15). Clean and reinstall the vented plug. Maintain the oil level at the middle of the sight gauges.

#### Bearings

### (Figure 2)

The bearing housing was fully lubricated when shipped from the factory. Check the oil level regularly through the sight gauges (15) and maintain it at the midpoint of the gauges. When lubrication is required, remove the pipe plugs (14) and add SAE No. 30 non-detergent oil through one of the openings. When lubricating a dry (overhauled) intermediate, fill the bearing cavity with approximately 50 ounces (1,5 liter) of oil. Clean and reinstall the pipe plugs. **Do not** over-lubricate. Over-lubrication can cause the bearings to over-heat, resulting in premature bearing failure.

Under normal conditions, drain the bearing housing once each year and refill with clean oil. Change the oil more frequently if the pump is operated continuously or installed in an environment with rapid temperature change.

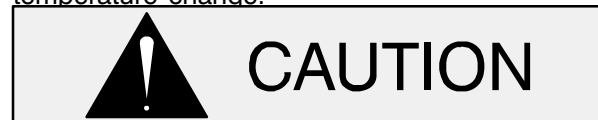

Monitor the condition of the bearing lubricant regularly for evidence of rust or moisture condensation. This is especially important in areas where variable hot and cold temperatures are common.

For cold weather operation, consult the factory or a lubricant supplier for the recommended grade of oil.

#### Power Source

Consult the literature supplied with the power source, or contact your local power source representative.

**For Warranty Information, Please Visit  
[www.grpumps.com/warranty](http://www.grpumps.com/warranty)  
or call:  
U.S.: 419-755-1280  
Canada: 519-631-2870  
International: +1-419-755-1352**

**GORMAN-RUPP PUMPS**