

**INSTALLATION, OPERATION,
AND MAINTENANCE MANUAL**
WITH PARTS LIST



RS & RD SERIES PUMP

MODEL
RD3A32-BAR

GORMAN-RUPP PUMPS

www.grpumps.com

Register your new
Gorman-Rupp pump online at
www.grpumps.com

Valid serial number and e-mail address required.

RECORD YOUR PUMP MODEL AND SERIAL NUMBER

Please record your pump model and serial number in the spaces provided below. Your Gorman-Rupp distributor needs this information when you require parts or service.

Pump Model: _____

Serial Number: _____

TABLE OF CONTENTS

INTRODUCTION	PAGE I – 1
SAFETY - SECTION A	PAGE A – 1
INSTALLATION – SECTION B	PAGE B – 1
Pump Dimensions	PAGE B – 1
PREINSTALLATION INSPECTION	PAGE B – 1
POSITIONING PUMP	PAGE B – 2
Lifting	PAGE B – 2
Mounting	PAGE B – 2
SUCTION AND DISCHARGE PIPING	PAGE B – 2
Materials	PAGE B – 2
Line Configuration	PAGE B – 2
Connections to Pump	PAGE B – 2
Gauges	PAGE B – 3
SUCTION LINES	PAGE B – 3
Fittings	PAGE B – 3
Strainers	PAGE B – 3
Sealing	PAGE B – 3
Suction Lines In Sumps	PAGE B – 3
Suction Line Positioning	PAGE B – 3
DISCHARGE LINES	PAGE B – 4
Siphoning	PAGE B – 4
Valves	PAGE B – 4
ALIGNMENT	PAGE B – 4
Coupled Drives	PAGE B – 5
OPERATION – SECTION C	PAGE C – 1
PRIMING	PAGE C – 1
Hand Primers	PAGE C – 1
STARTING	PAGE C – 1
OPERATION	PAGE C – 2
Leakage	PAGE C – 2
Liquid Temperature And Overheating	PAGE C – 2
Strainer Check	PAGE C – 2
Pump Vacuum Check	PAGE C – 2
STOPPING	PAGE C – 2
Cold Weather Preservation	PAGE C – 2
BEARING TEMPERATURE CHECK	PAGE C – 3
TROUBLESHOOTING – SECTION D	PAGE D – 1
PREVENTIVE MAINTENANCE	PAGE D – 3
PUMP MAINTENANCE AND REPAIR - SECTION E	PAGE E – 1
STANDARD PERFORMANCE CURVE	PAGE E – 1
PARTS LISTS:	
Pump Model	PAGE E – 3

TABLE OF CONTENTS
(continued)

Bearing Housing Assembly	PAGE E – 5
Typical RD Pump Model Assembly	PAGE E – 6
Typical Bearing Housing Assembly	PAGE E – 7
Group Grind	PAGE E – 8
PUMP AND SEAL DISASSEMBLY AND REASSEMBLY	PAGE E – 9
Separating Pump From Motor	PAGE E – 10
Air Release Valve Removal	PAGE E – 10
Pump Disassembly	PAGE E – 10
Impeller Removal	PAGE E – 10
Group Grind Disassembly	PAGE E – 11
Seal Removal	PAGE E – 11
Shaft And Bearing Removal And Disassembly	PAGE E – 11
Shaft and Bearing Reassembly and Installation	PAGE E – 12
Seal Reassembly and Installation	PAGE E – 13
Group Grind Reassembly	PAGE E – 15
Group Grind Check	PAGE E – 15
Group Grind Replacement	PAGE E – 16
Group Grind Check	PAGE E – 17
Impeller Installation	PAGE E – 17
Pump Reassembly	PAGE E – 17
Final Pump Assembly	PAGE E – 17
LUBRICATION	PAGE E – 17
Seal Assembly	PAGE E – 17
Group Grind	PAGE E – 17
Bearings	PAGE E – 17

INTRODUCTION

Thank You for purchasing a Gorman-Rupp pump. **Read this manual** carefully to learn how to safely install and operate your pump. Failure to do so could result in personal injury or damage to the pump.

This manual will alert personnel to known procedures which require special attention, to those which could damage equipment, and to those which could be dangerous to personnel. However, this manual cannot possibly anticipate and provide detailed precautions for every situation that might occur during maintenance of the unit. Therefore, it is the responsibility of the owner/maintenance personnel to ensure that **only** safe, established maintenance procedures are used, and that any procedures not addressed in this manual are performed **only** after establishing that neither personal safety nor pump integrity are compromised by such practices.

If there are any questions regarding the pump or its application which are not covered in this manual or in other literature accompanying this unit, please contact your Gorman-Rupp distributor, or the Gorman-Rupp Company:

The Gorman-Rupp Company
P.O. Box 1217
Mansfield, Ohio 44901-1217
Phone: (419) 755-1011
 or:
Gorman-Rupp of Canada Limited
70 Burwell Road
St. Thomas, Ontario N5P 3R7
Phone: (519) 631-2870

For information or technical assistance on the power source, contact the power source manufacturer's local dealer or representative.

The following are used to alert maintenance personnel to procedures which require special attention, to those which could damage equipment, and to those which could be dangerous to personnel:



Immediate hazards which WILL result in severe personal injury or death. These instructions describe the procedure required and the injury which will result from failure to follow the procedure.



Hazards or unsafe practices which COULD result in severe personal injury or death. These instructions describe the procedure required and the injury which could result from failure to follow the procedure.



Hazards or unsafe practices which COULD result in minor personal injury or product or property damage. These instructions describe the requirements and the possible damage which could result from failure to follow the procedure.

NOTE

Instructions to aid in installation, operation, and maintenance, or which clarify a procedure.

SAFETY – SECTION A

The following information applies throughout this manual to Gorman-Rupp Roto-Prime® Series basic pumps.

This manual will alert personnel to known procedures which require special attention, to those which could damage equipment, and to those which could be dangerous to personnel. However, this manual cannot possibly anticipate and provide detailed instructions and precautions for every situation that might occur during maintenance of the unit. Therefore, it is the responsibility of the owner/maintenance personnel to ensure that only safe, established maintenance procedures are used, and that any procedures not addressed in this manual are performed only after establishing that neither personal safety nor pump integrity are compromised by such practices.



Before attempting to open or service the pump:

1. Familiarize yourself with this manual.
2. Lock out or disconnect the power source or take other precautions to ensure that the pump will remain inoperative.
3. Allow the pump to completely cool if overheated.
4. Check the temperature before opening any covers, plates, or plugs.
5. Close the suction and discharge valves.
6. Vent the pump slowly and cautiously.
7. Drain the pump.



This pump is designed to handle petroleum products or other similar hydrocarbon liquids. Do not attempt to pump water, corrosive materials, or any liquids which may damage the pump or endanger personnel as a result of pump failure.



After the pump has been positioned, make certain that the pump and all piping connections are tight, properly supported and secure before operation.



Death or serious personal injury and damage to the pump or components can occur if proper lifting procedures are not observed. Make certain that hoists, chains, slings or cables are in good working condition and of sufficient capacity and that they are positioned so that loads will be balanced and the pump or components will not be damaged when lifting. Suction and discharge hoses and piping must be removed from the pump before lifting. Lift the pump or component only as high as necessary and keep personnel away from suspended objects.



Do not operate the pump against a closed discharge valve for long periods of time. If operated against a closed discharge valve, pump components will

deteriorate, and the liquid could come to a boil, build pressure, and cause the pump casing to rupture or explode.



If this pump is used with volatile and/or flammable liquids, be certain proper safety practices are followed before operating or servicing the pump. Provide adequate ventilation, prohibit smoking, wear static-resistant clothing and shoes. Clean up all fuel spills immediately after occurrence.



Overheated pumps can cause severe burns and injuries, and produce explosive fumes. If overheating of the pump occurs:

1. Stop the pump immediately.
2. Ventilate the area.
3. Allow the pump to completely cool.
4. Check the temperature before opening any covers, plates, gauges, or plugs.

5. Vent the pump slowly and cautiously.
6. Refer to instructions in this manual before restarting the pump.



Do not remove plates, covers, gauges, pipe plugs, or fittings from an overheated pump. Vapor pressure within the pump can cause parts being disengaged to be ejected with great force. Allow the pump to cool before servicing.



Do not install and operate a non-explosion proof motor in an explosive atmosphere. Install, connect, and operate the motor in accordance with The National Electric Code and all local codes. If there is a conflict between the instructions in the manual accompanying the unit and The National Electric Code or the applicable local code, The National or local code shall take precedence. All electrical equipment supplied with this pump conformed to applicable federal regulations and national codes in effect on the date of manufacture.

INSTALLATION – SECTION B

Review all SAFETY information in Section A.

Since pump installations are seldom identical, this section offers only general recommendations and practices required to inspect, position, and arrange the pump and piping.

Most of the information pertains to a standard **static lift** application where the pump is positioned above the free level of liquid to be pumped.

If installed in a **flooded suction application** where the liquid is supplied to the pump under pressure, some of the information such as mounting, line configuration, and priming must be tailored to the

specific application. Since the pressure supplied to the pump is critical to performance and safety, **be sure** to limit the incoming pressure to 50% of the maximum permissible operating pressure as shown on the pump performance curve (see Section E, Page 1).

For further assistance, contact your Gorman-Rupp distributor or the Gorman-Rupp Company.

Pump Dimensions

See Figure 1 for the approximate physical dimensions of this pump.

OUTLINE DRAWING

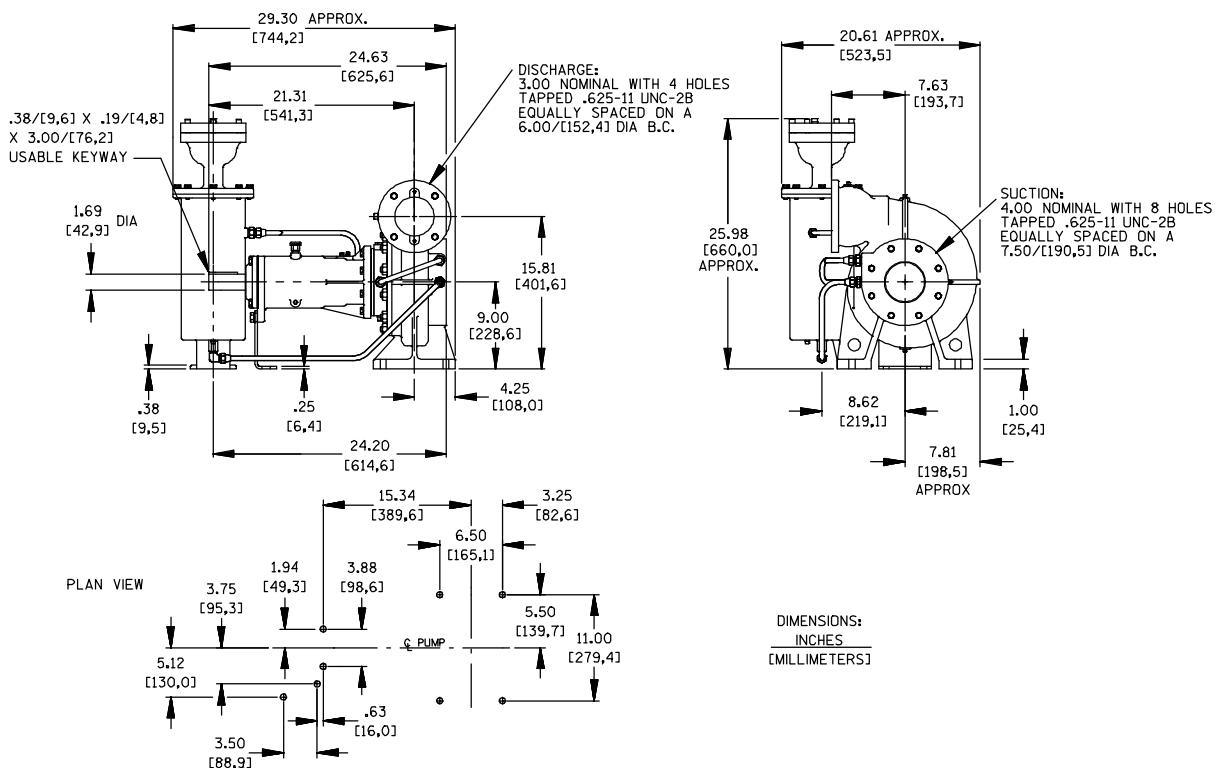

Figure 1. Pump Model RD3A32-BAR

PREINSTALLATION INSPECTION

The pump assembly was inspected and tested before shipment from the factory. Before installation, inspect the pump for damage which may have occurred during shipment. Check as follows:

- a. Inspect the pump and engine for cracks, dents, damaged threads, and other obvious damage.
- b. Check for and tighten loose attaching hardware. Since gaskets tend to shrink after dry-

ing, check for loose hardware at mating surfaces.

- c. Carefully read all tags, decals, and markings on the pump assembly, and perform all duties indicated.
- d. Check levels and lubricate as necessary. Refer to **LUBRICATION** in the **MAINTENANCE AND REPAIR** section of this manual and perform duties as instructed.
- e. If the pump has been stored for more than 12 months, some of the components or lubricants may have exceeded their maximum shelf life. These **must be inspected or replaced** to ensure maximum pump service.

If the maximum shelf life has been exceeded, or if anything appears to be abnormal, contact your Gorman-Rupp distributor or the factory to determine the repair or updating policy. **Do not** put the pump into service until appropriate action has been taken.

POSITIONING PUMP

Lifting

Pump unit weights will vary depending on the mounting and drive provided. Check the shipping tag on the unit packaging for the actual weight, and use lifting equipment with appropriate capacity. Drain the pump and remove all customer-installed equipment such as suction and discharge hoses or piping before attempting to lift existing, installed units.



Death or serious personal injury and damage to the pump or components can occur if proper lifting procedures are not observed. Make certain that hoists, chains, slings or cables are in good working condition and of sufficient capacity and that they are positioned so that loads will be balanced and the pump or components will not be

damaged when lifting. Suction and discharge hoses and piping must be removed from the pump before lifting. Lift the pump or component only as high as necessary and keep personnel away from suspended objects.

Mounting

Locate the pump in an accessible place as close as practical to the liquid being pumped. Level mounting is essential for proper operation.

The pump may have to be supported or shimmed to provide for level operation or to eliminate vibration.

SUCTION AND DISCHARGE PIPING

Materials

Either pipe or hose maybe used for suction and discharge lines; however, the materials must be compatible with the liquid being pumped. If hose is used in suction lines, it must be the rigid-wall, reinforced type to prevent collapse under suction. Using piping couplings in suction lines is not recommended.

Line Configuration

Keep suction and discharge lines as straight as possible to minimize friction losses. Make minimum use of elbows and fittings, which substantially increase friction loss. If elbows are necessary, use the long-radius type to minimize friction loss.

Connections to Pump

Before tightening a connecting flange, align it exactly with the pump port. Never pull a pipe line into place by tightening the flange bolts and/or couplings.

Lines near the pump must be independently supported to avoid strain on the pump which could cause excessive vibration, decreased bearing life, and increased shaft and seal wear. If hose-type lines are used, they should have adequate support to secure them when filled with liquid and under pressure.

Gauges

Most pumps are drilled and tapped for installing discharge pressure and vacuum suction gauges. If these gauges are desired for pumps that are not tapped, drill and tap the suction and discharge lines not less than 18 inches (457,2 mm) from the suction and discharge ports and install the lines. Installation closer to the pump may result in erratic readings.

SUCTION LINES

To avoid air pockets which could affect pump priming, the suction line must be as short and direct as possible. When operation involves a suction lift, the line must always slope upward to the pump from the source of the liquid being pumped; if the line slopes down to the pump at any point along the suction run, air pockets will be created.

Fittings

Suction lines should be the same size as the pump inlet. If reducers are used in suction lines, they should be the eccentric type, and should be installed with the flat part of the reducers uppermost to avoid creating air pockets. Valves are not normally used in suction lines, but if a valve is used, install it with the stem horizontal to avoid air pockets.

Strainers

If a strainer is not furnished with the pump, but is installed by the pump user, make certain that the total area of the openings in the strainer is at least three or four times the cross section of the suction line, and that the openings will not permit passage of solids larger than the solids handling capability of the pump.

This pump is designed to handle up to 2-inch (50,8 mm) diameter spherical solids.

Sealing

Since even a slight leak will affect priming, head, and capacity, especially when operating with a

high suction lift, all connections in the suction line should be sealed with pipe dope to ensure an airtight seal. Follow the sealant manufacturer's recommendations when selecting and applying the pipe dope. The pipe dope should be compatible with the liquid being pumped.

Suction Lines In Sumps

If a single suction line is installed in a sump, it should be positioned away from the wall of the sump at a distance equal to 1–1/2 times the diameter of the suction line.

If there is a liquid flow from an open pipe into the sump, the flow should be kept away from the suction inlet because the inflow will carry air down into the sump, and air entering the suction line will reduce pump efficiency.

If it is necessary to position inflow close to the suction inlet, install a baffle between the inflow and the suction inlet at a distance 1–1/2 times the diameter of the suction pipe. The baffle will allow entrained air to escape from the liquid before it is drawn into the suction inlet.

If two suction lines are installed in a single sump, the flow paths may interact, reducing the efficiency of one or both pumps. To avoid this, position the suction inlets so that they are separated by a distance equal to at least 3 times the diameter of the suction pipe.

Suction Line Positioning

The depth of submergence of the suction line is critical to efficient pump operation. Figure 2 shows recommended minimum submergence vs. velocity.

NOTE

The pipe submergence required may be reduced by installing a standard pipe increaser fitting at the end of the suction line. The larger opening size will reduce the inlet velocity. Calculate the required submergence using the following formula based on the increased opening size (area or diameter).

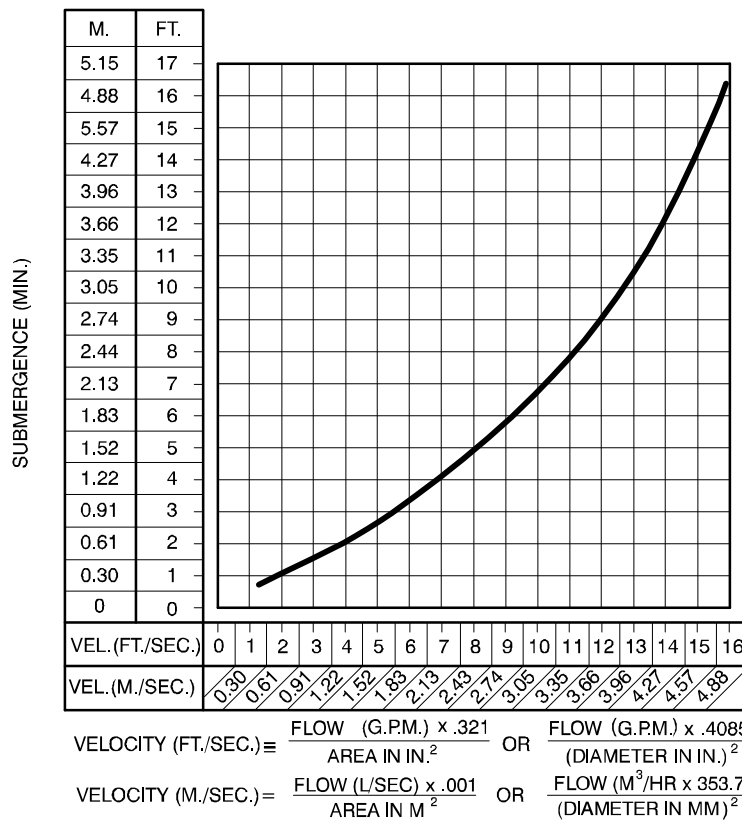

Figure 2. Recommended Minimum Suction Line Submergence vs. Velocity

DISCHARGE LINES

Siphoning

Do not terminate the discharge line at a level lower than that of the liquid being pumped unless a siphon breaker is used in the line. Otherwise, a siphoning action causing damage to the pump could result.

Valves

If a throttling valve is desired in the discharge line, use a valve as large as the largest pipe to minimize friction losses. Never install a throttling valve in a suction line.

With high discharge heads, it is recommended that a throttling valve and a system check valve be installed in the discharge line to protect the pump from excessive shock pressure and reverse rotation when it is stopped.



If the application involves a high discharge head, gradually close the discharge throttling valve before stopping the pump.

ALIGNMENT



This pump is designed for direct coupled drive only. Use of a V-belt drive will damage the pump and void the pump warranty.

The alignment of the pump and its power source is critical for trouble-free mechanical operation. The driver and pump must be mounted so that their shafts are aligned with and parallel to each other. It is imperative that alignment be checked after the pump and piping are installed, and before operation.

NOTE

Check **Rotation**, Section C, before final alignment of the pump.

When mounted at the Gorman-Rupp factory, driver and pump are aligned before shipment. Misalignment will occur in transit and handling. Pumps **must** be checked and realigned before operation. Before checking alignment, tighten the foundation bolts. The pump casing feet and/or pedestal feet, and the driver mounting bolts should also be tightly secured.



When checking alignment, disconnect the power source to ensure that the pump will remain inoperative.



Adjusting the alignment in one direction may alter the alignment in another direction. Check each procedure after altering alignment.

Coupled Drives

When using couplings, the axis of the power source must be aligned to the axis of the pump shaft in both the horizontal and vertical planes. Most couplings require a specific gap or clearance between the driving and the driven shafts. Refer to the coupling manufacturer's service literature.

Align spider insert type couplings by using calipers to measure the dimensions on the circumference of the outer ends of the coupling hub every 90°. The coupling is in alignment when the hub ends are the same distance apart at all points (see Figure 3A).

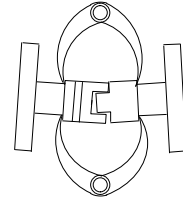

Figure 3A. Aligning Spider-Type Couplings

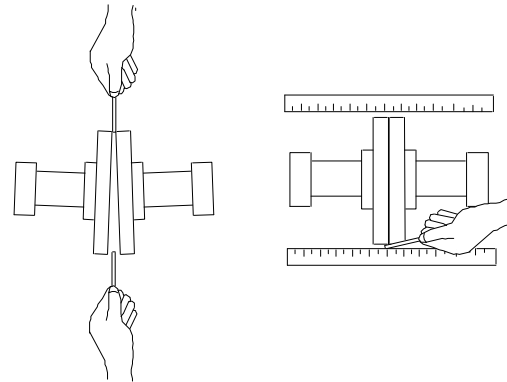

Figure 3B. Aligning Non-Spider Type Couplings

Align non-spider type couplings by using a feeler gauge or taper gauge between the coupling halves every 90°. The coupling is in alignment when the hubs are the same distance apart at all points (see Figure 3B).

Check parallel adjustment by laying a straightedge across both coupling rims at the top, bottom, and side. When the straightedge rests evenly on both halves of the coupling, the coupling is in horizontal parallel alignment. If the coupling is misaligned, use a feeler gauge between the coupling and the straightedge to measure the amount of misalignment.



Do not operate the pump without the guard in place over the rotating parts. Exposed rotating parts can catch clothing, fingers, or tools, causing severe injury to personnel.

OPERATION – SECTION C

Review all **SAFETY** information in Section A.

Follow the instructions on all tags, labels and decals attached to the pump.



This pump is designed to handle most non-volatile, non-flammable liquids containing specified entrained solids. Do not attempt to pump volatile, corrosive, or flammable liquids which may damage the pump or endanger personnel as a result of pump failure.

PRIMING

Install the pump and piping as described in **INSTALLATION**. Make sure that the piping connections are tight, and that the pump is securely mounted. Check that the pump is properly lubricated (see **LUBRICATION** in **MAINTENANCE AND REPAIR**).

This is not a self-priming pump, so an external priming device must be used if the pump is installed on a **suction lift**. A foot valve may be installed at the end of the suction pipe to maintain the prime; however, this may adversely affect pump performance due to friction loss. Many standard centrifugal models are equipped with a hand-operated vacuum pump, exhaust primer, or ejector for this purpose. If a priming device was not furnished with the pump, it may be ordered from the factory as an option.

Before attempting to operate the priming device, close the discharge throttling valve. (Installation of a spring-loaded check valve is also recommended to facilitate priming.) Once the pump is fully primed, close the valve between the priming device and pump to preserve the prime. Start the pump and open the discharge valve slowly to fill the discharge line.



Never operate this pump unless there is liquid in the pump casing. The pump will not prime when dry. Extended operation of a dry pump will destroy the seal assembly.

Hand Primers

Hand-operated primers are usually mounted on the pump and, when operated, draw air out of the suction line and pump casing. To prime a pump with a hand vacuum pump, open the cock on the pump priming line. Operate the hand pump until liquid flows out of the check valve on the bottom of the primer pump. Once the pump is primed, close the valve located between the primer and the pump so that the prime will not be lost.

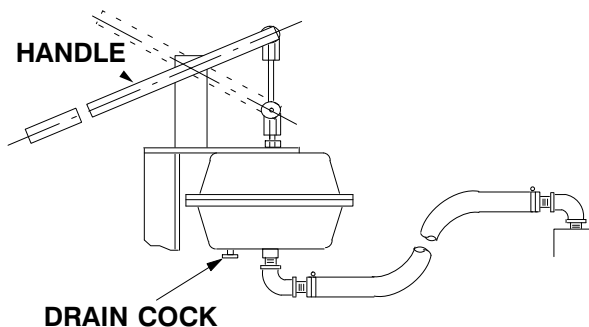

Figure 1. Hand Primer Assembly

STARTING

Consult the operations manual furnished with the power source.

OPERATION

Leakage

No leakage should be visible at pump mating surfaces, or at pump connections or fittings. Keep all line connections and fittings tight to maintain maximum pump efficiency.

Liquid Temperature And Overheating

The **maximum** liquid temperature for this pump is 160°F (71°C). Do not apply it at a higher operating temperature.

Overheating can occur if operated with the valves in the suction or discharge lines closed. Operating against closed valves could bring the liquid to a boil, build pressure, and cause the pump to rupture or explode. If overheating occurs, stop the pump and allow it to cool before servicing it. Refill the pump casing with cool liquid.



Allow an over-heated pump to cool before servicing. Do not remove plates, covers, gauges, or fittings from an over-heated pump. Liquid within the pump can reach boiling temperatures, and vapor pressure within the pump can cause parts being disengaged to be ejected with great force. After the pump cools, drain the liquid from the pump by removing the casing drain plug. Use caution when removing the plug to prevent injury to personnel from hot liquid.

Strainer Check

If a suction strainer has been shipped with the pump or installed by the user, check the strainer regularly, and clean it as necessary. The strainer should also be checked if pump flow rate begins to drop. If a vacuum suction gauge has been installed, monitor and record the readings regularly to detect strainer blockage.

Never introduce air or steam pressure into the pump casing or piping to remove a blockage. This could result in personal injury or damage to the equipment. If backflushing is absolutely necessary, **liquid pressure** must be limited to 50% of the maximum permissible operating pressure shown on the pump performance curve (see Section E, Page 1).

Pump Vacuum Check

Since this pump does not have a suction check valve, the discharge line must be fitted with a check valve if a pump vacuum reading is to be taken.

With the pump inoperative, install a vacuum gauge in the system, using pipe dope on the threads. Block the suction line and start the pump. At operating speed the pump should pull a vacuum of 20 inches or more of mercury. If it does not, check for air leaks in the seal, gasket, or discharge valve.

Open the suction line, and read the vacuum gauge with the pump primed and at operation speed. Shut off the pump. The vacuum gauge reading will immediately drop proportionate to static suction lift, and should then stabilize. If the vacuum reading falls off rapidly after stabilization, an air leak exists. Before checking for the source of the leak, check the point of installation of the vacuum gauge.

STOPPING

Never halt the flow of liquid suddenly. If the liquid being pumped is stopped abruptly, damaging shock waves can be transmitted to the pump and piping system. Close all connecting valves slowly.

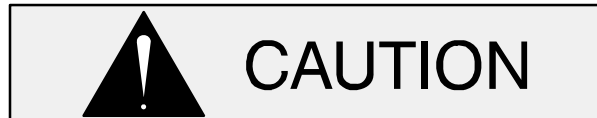

If the application involves a high discharge head, gradually close the discharge throttling valve before stopping the pump.

After stopping the pump, disconnect the power source to ensure that the pump will remain inoperative.

Cold Weather Preservation

In below freezing conditions, drain the pump to prevent damage from freezing. Also, clean out any

solids by flushing with a hose. Operate the pump for approximately one minute; this will remove any remaining liquid that could freeze the pump rotating parts. If the pump will be idle for more than a few hours, or if it has been pumping liquids containing a large amount of solids, drain the pump, and flush it thoroughly with clean water. To prevent large solids from clogging the drain port and preventing the pump from completely draining, insert a rod or stiff wire in the drain port, and agitate the liquid during the draining process. Clean out any remaining solids by flushing with a hose.

BEARING TEMPERATURE CHECK

Bearings normally run at higher than ambient temperatures because of heat generated by friction. Temperatures up to 160°F (71°C) are considered

normal for bearings, and they can operate safely to at least 180°F (82°C).

Checking bearing temperatures by hand is inaccurate. Bearing temperatures can be measured accurately by placing a contact-type thermometer against the housing. Record this temperature for future reference.

A sudden increase in bearing temperatures is a warning that the bearings are at the point of failing to operate properly. Make certain that the bearing lubricant is of the proper viscosity and at the correct level (see **LUBRICATION** in Section E). Bearing overheating can also be caused by shaft misalignment and/or excessive vibration.

When pumps are first started, the bearings may seem to run at temperatures above normal. Continued operation should bring the temperatures down to normal levels.

TROUBLESHOOTING – SECTION D

Review all **SAFETY** information in Section A.



Before attempting to open or service the pump:

1. Familiarize yourself with this manual.
2. Lock out or disconnect the power source to ensure that the pump will remain inoperative.
3. Allow the pump to completely cool if overheated.
4. Check the temperature before opening any covers, plates, or plugs.
5. Close the suction and discharge valves.
6. Vent the pump slowly and cautiously.
7. Drain the pump.

TROUBLE	POSSIBLE CAUSE	PROBABLE REMEDY
PUMP FAILS TO PRIME	Air leak in suction line. Lining of suction hose collapsed. Leaking or worn seal or pump gasket. Suction lift or discharge head too high. Strainer clogged. Suction check valve or foot valve clogged or binding.	Correct leak. Replace suction hose. Check pump vacuum. Replace leaking or worn seal or gasket. Check piping installation and install bypass line if needed. See INSTALLATION . Check strainer and clean if necessary. Clean valve.
PUMP STOPS OR FAILS TO DELIVER RATED FLOW OR PRESSURE	Air leak in suction line. Lining of suction hose collapsed. Pump speed too high. Impeller or other wearing parts worn or damaged. Strainer clogged.	Correct leak. Replace suction hose. Check driver output. Replace worn or damaged parts. Check that impeller is properly centered and rotates freely. Check strainer and clean if necessary.

TROUBLE	POSSIBLE CAUSE	PROBABLE REMEDY
PUMP STOPS OR FAILS TO DELIVER RATED FLOW OR PRESSURE (cont.)	<p>Pump speed too slow.</p> <p>Impeller clogged.</p> <p>Suction lift too high.</p> <p>Leaking or worn seal or pump gasket.</p> <p>Discharge head too high.</p> <p>Suction intake not submerged at proper level or sump too small.</p>	<p>Check driver output; consult the operation manual.</p> <p>Free impeller of debris.</p> <p>Measure lift w/vacuum gauge. Reduce lift and/or friction losses in suction line.</p> <p>Check pump vacuum. Replace leaking or worn seal or gasket.</p> <p>Install bypass line.</p> <p>Check installation and correct submergence as needed.</p>
PUMP REQUIRES TOO MUCH POWER	<p>Pump speed too high.</p> <p>Discharge head too low.</p> <p>Liquid solution too thick.</p>	<p>Check driver output.</p> <p>Adjust discharge valve.</p> <p>Dilute if possible.</p>
PUMP CLOGS FREQUENTLY	<p>Discharge flow too slow.</p> <p>Suction check valve or foot valve clogged or binding.</p>	<p>Open discharge valve fully to increase flow rate, and run driver at maximum governed speed.</p> <p>Clean valve.</p>
EXCESSIVE NOISE	<p>Cavitation in pump.</p> <p>Pumping entrained air.</p> <p>Pump or drive not securely mounted.</p> <p>Impeller clogged or damaged.</p>	<p>Reduce suction lift and/or friction losses in suction line. Record vacuum and pressure gauge readings and consult local representative or factory.</p> <p>Locate and eliminate source of air bubble.</p> <p>Secure mounting hardware.</p> <p>Clean out debris; replace damaged parts.</p>
BEARINGS RUN TOO HOT	<p>Bearing temperature is high, but within limits.</p> <p>Low or incorrect lubricant.</p> <p>Suction and discharge lines not properly supported.</p> <p>Drive misaligned.</p>	<p>Check bearing temperature regularly to monitor any increase.</p> <p>Check for proper type and level of lubricant.</p> <p>Check piping installation for proper support.</p> <p>Align drive properly.</p>

PREVENTIVE MAINTENANCE

Since pump applications are seldom identical, and pump wear is directly affected by such things as the abrasive qualities, pressure and temperature of the liquid being pumped, this section is intended only to provide general recommendations and practices for preventive maintenance. Regardless of the application however, following a routine preventive maintenance schedule will help assure trouble-free performance and long life from your Gorman-Rupp pump. For specific questions concerning your application, contact your Gorman-Rupp distributor or the Gorman-Rupp Company.

Record keeping is an essential component of a good preventive maintenance program. Changes in suction and discharge gauge readings (if so

equipped) between regularly scheduled inspections can indicate problems that can be corrected before system damage or catastrophic failure occurs. The appearance of wearing parts should also be documented at each inspection for comparison as well. Also, if records indicate that a certain part (such as the seal) fails at approximately the same duty cycle, the part can be checked and replaced before failure occurs, reducing unscheduled down time.

For new applications, a first inspection of wearing parts at 250 hours will give insight into the wear rate for your particular application. Subsequent inspections should be performed at the intervals shown on the chart below. Critical applications should be inspected more frequently.

Preventive Maintenance Schedule					
Item	Service Interval*				
	Daily	Weekly	Monthly	Semi-Annually	Annually
General Condition (Temperature, Unusual Noises or Vibrations, Cracks, Leaks, Loose Hardware, Etc.)	I				
Pump Performance (Gauges, Speed, Flow)	I				
Bearing Lubrication		I			R
Seal Lubrication (And Packing Adjustment, If So Equipped)		I			R
V-Belts (If So Equipped)			I		
Air Release Valve Plunger Rod (If So Equipped)			I	C	
Front Impeller Clearance (Wear Plate)				I	
Rear Impeller Clearance (Seal Plate)				I	
Check Valve					I
Pressure Relief Valve (If So Equipped)					C
Pump and Driver Alignment					I
Shaft Deflection					I
Bearings					I
Bearing Housing					I
Piping					I
Driver Lubrication – See Mfgr's Literature					I
Legend: I = Inspect, Clean, Adjust, Repair or Replace as Necessary C = Clean R = Replace * Service interval based on an intermittent duty cycle equal to approximately 4000 hours annually. Adjust schedule as required for lower or higher duty cycles or extreme operating conditions.					

PUMP MAINTENANCE AND REPAIR - SECTION E

MAINTENANCE AND REPAIR OF THE WEARING PARTS OF THE PUMP WILL MAINTAIN PEAK OPERATING PERFORMANCE.

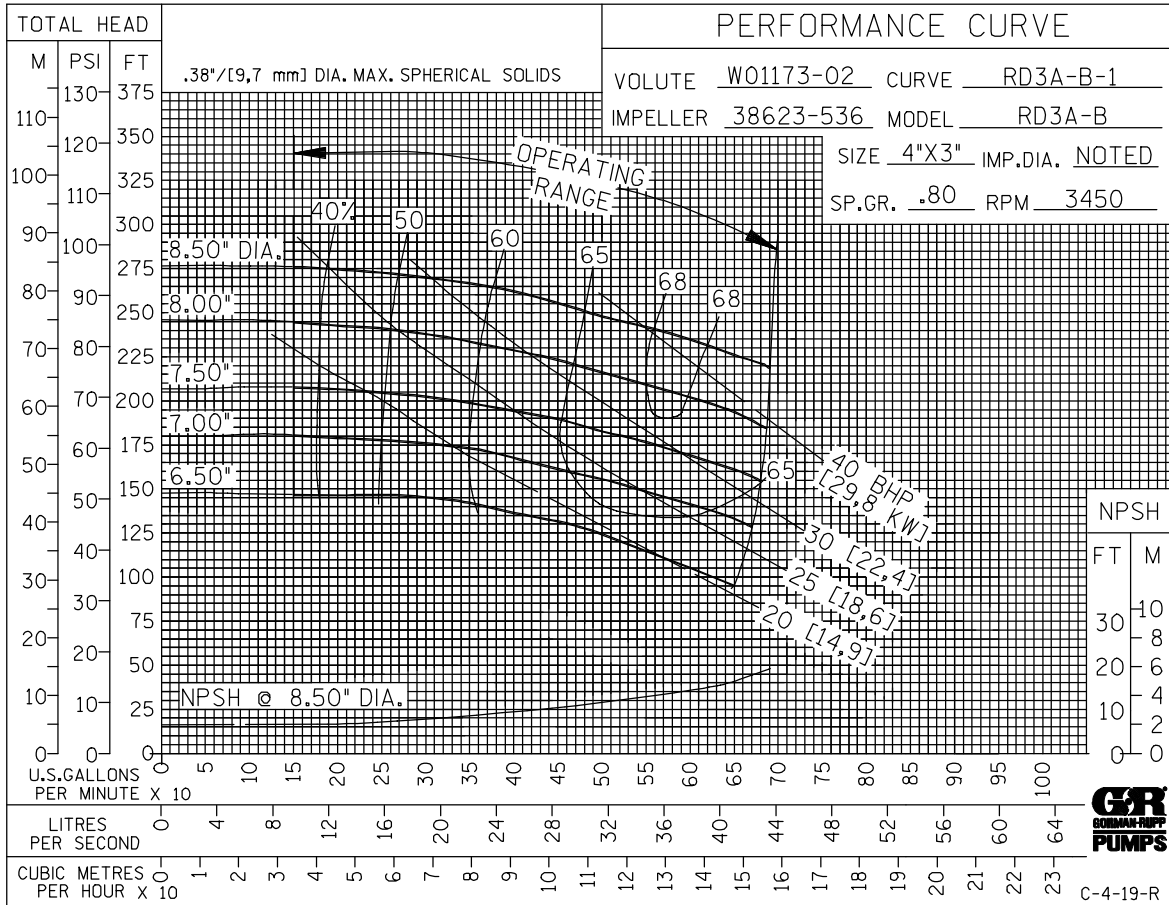

ILLUSTRATION

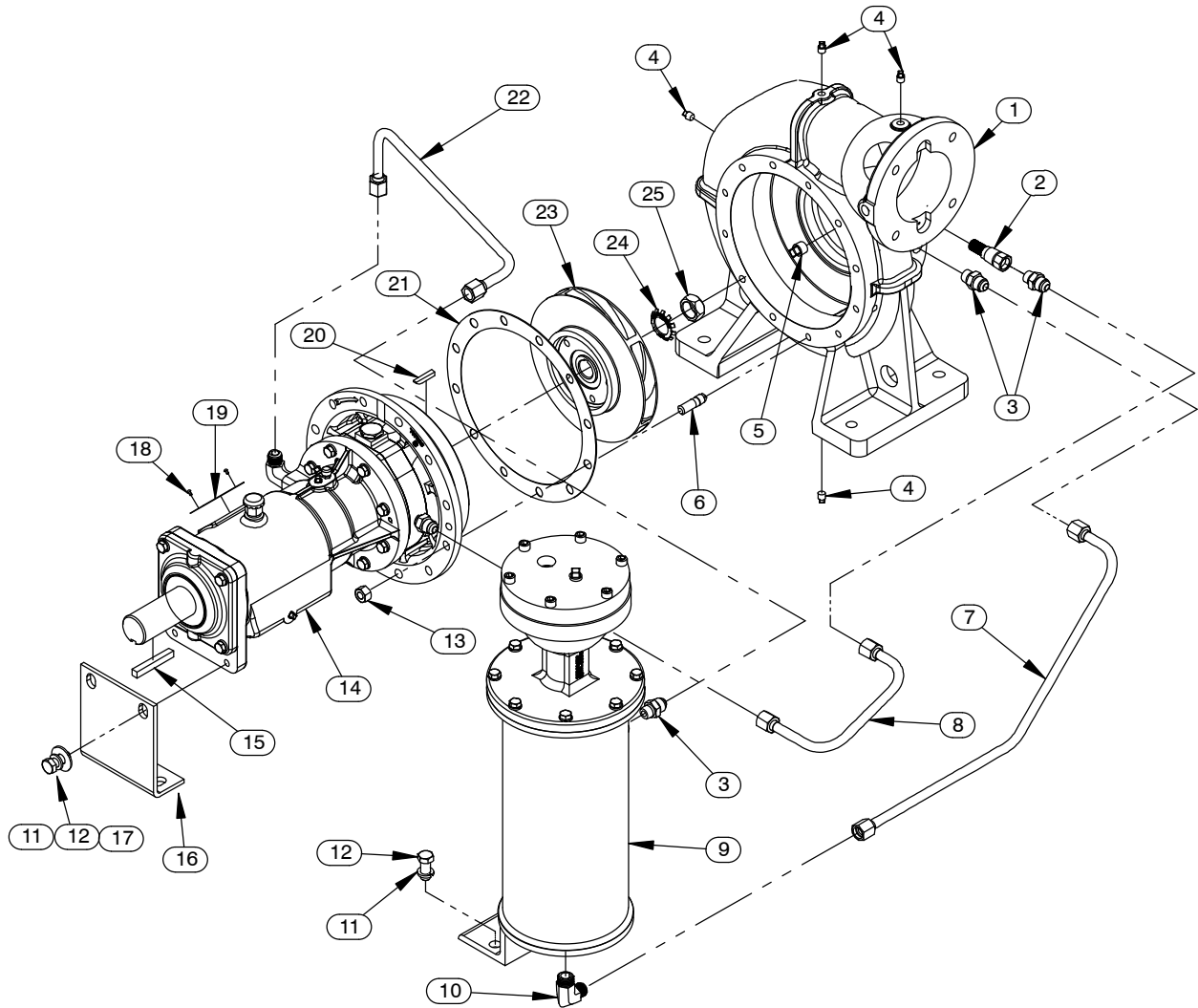

Figure 1. Pump Model RD3A32-BAR

PARTS LIST
Pump Model RD3A32-BAR
 (From S/N 1695564 Up)

If your pump serial number is followed by an "N", your pump is **NOT** a standard production model. Contact the Gorman-Rupp Company to verify part numbers.

ITEM NO.	PART NAME	PART NUMBER	QTY
☞ 1	PUMP CASING BODY	SEE NOTE BELOW	1
2	STRAINER	26841-094	1
3	CONNECTOR	25812-214	3
☞ 4	PIPE PLUG	P02 15079	4
☞ 5	PIPE PLUG	P06 15079	1
☞ 6	STUD	C0807 15991	12
7	RETURN TUBE ASSEMBLY	46335-086	1
8	SUCTION TUBE ASSEMBLY	46335-076	1
9	AIR RELEASE VALVE ASSEMBLY	GRP33-08B	1
10	MALE ELBOW	25812-011	1
11	LOCK WASHER	J08 15991	4
12	HEX HEAD CAP SCREW	B0805 15991	4
☞ 13	HEX NUT	D08 15991	12
14	BEARING HOUSING ASSEMBLY	44143-105	1
15	* SHAFT KEY	N0611 15990	1
16	SUPPORT BRG HOUSING	R12852-01 15990	1
17	FLAT WASHER	K08 15991	2
18	DRIVE SCREW	BM#04-03 17000	2
19	NAME PLATE	2613DZ 13990	1
20	* IMPELLER KEY	K79329-23 15990	1
21	* PUMP CASING GASKET	R12531 20000	1
22	DISCHARGE TUBE ASSY	46335-097	1
23	* IMPELLER	38623-536 13048	1
24	LOCK WASHER	23962-519	1
25	* IMPELLER NUT	K75776 15111	1
NOT SHOWN:			
	LUBRICATION DECAL	38816-081	1
	DISCHARGE STICKER	6588BJ	1
	SUCTION STICKER	6588AG	1
	G-R DECAL	GR-03	1
	INSTRUCTION TAG	38817-011	1
	BEARING TAG	6588ABB	1
	ROTATION DECAL	2613M	1
	* CHECK VALVE BODY GASKET	11589GA 18000	1
☞	INCLUDED W/REPAIR PUMP CASING ASSY	46474-351	1

* INDICATES PARTS RECOMMENDED FOR STOCK

ILLUSTRATION

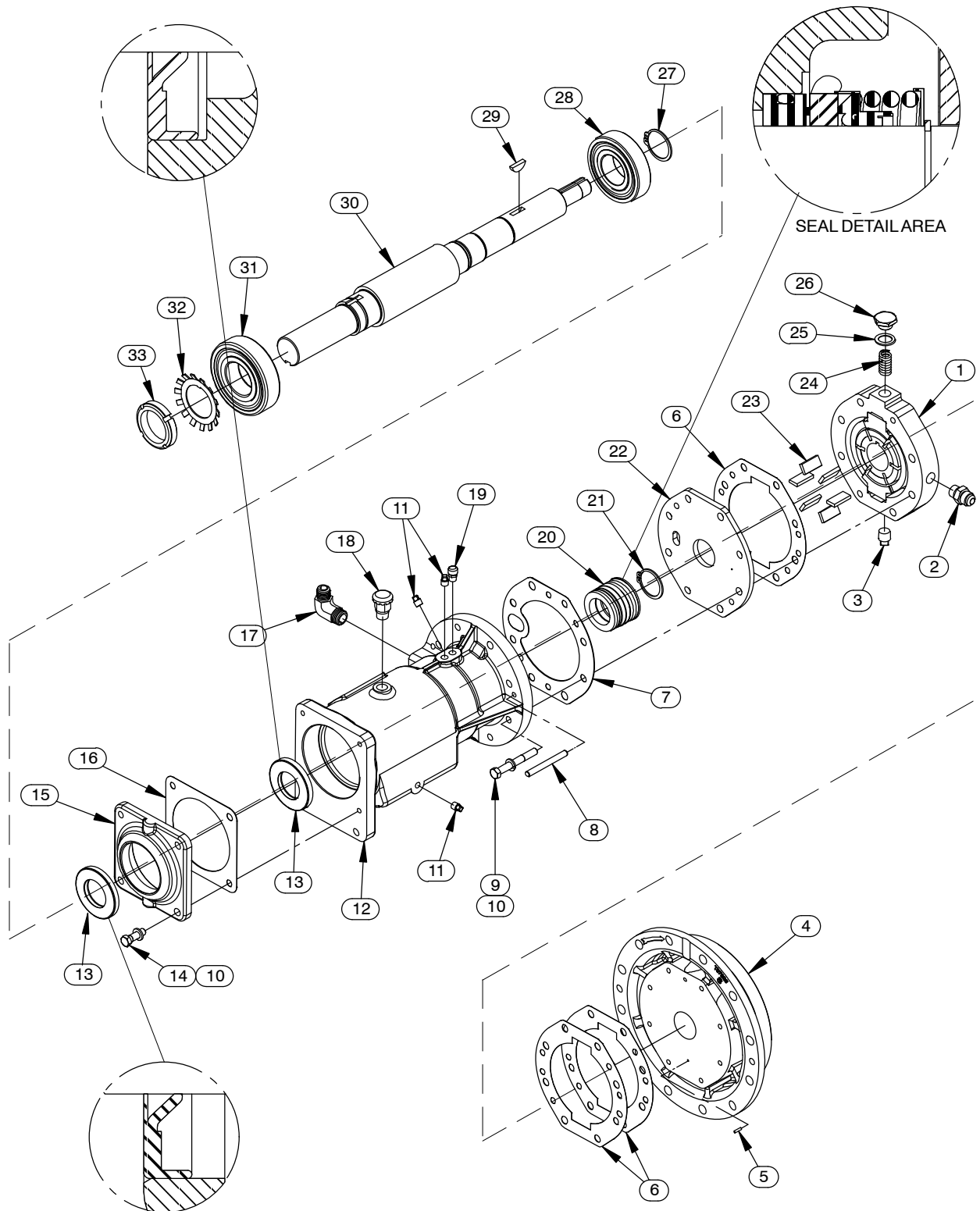

Figure 2. Bearing Housing Assembly

PARTS LIST

Bearing Housing Assembly

ITEM NO.	PART NAME	PART NUMBER	QTY
1	GROUP GRIND	LK05418	1
2	CONNECTOR	25812-214	1
3	PIPE PLUG	P06 15079	1
4	BODY COVER	T07826-04 10140	1
5	ROLL PIN	21154-666	1
6	* CENTER PLATE GASKET	N14145 18010	3
7	* SPACER PLATE GASKET	N14144 18000	1
8	DOWEL PIN	21133-073	2
9	HEX HEAD CAP SCREW	B0612 15991	8
10	LOCK WASHER	J06 15991	12
11	PIPE PLUG	P02 15079	3
12	BEARING HOUSING	W01172-03 11010	1
13	* OIL SEAL	25227-240	2
14	HEX HEAD CAP SCREW	B0605 15991	4
15	BEARING HOUSING CAP	R12770-02 10010	1
16	* BEARING CAP GASKET	N18938-01 18000	1
17	MALE ELBOW	25812-011	1
18	AIR VENT	S1703	1
19	AIR VENT	S2162	1
20	* MECH SEAL 1-5/8	25271-921	1
21	RETAINING RING	24124-243	1
22	SPACER PLATE	N14129-02 11010	1
23	PUMP BLADE	K79300-22	6
24	PRESSURE REGULATING SPRING	K76301	1
25	* GASKET	38681-021 19060	1
26	SPRING CAP	K68064 15991	1
27	RETAINING RING	24124-245	1
28	* BALL BEARING	23282-010	1
29	WOODRUFF KEY	K61559 15990	1
30	* IMPELLER SHAFT	T08467-02 15010	1
31	* BALL BEARING	23282-011	1
32	BRG LOCKWASHER	23962-511	1
33	BRG LOCKNUT	23962-011	1

* INDICATES PARTS RECOMMENDED FOR STOCK

SECTION DRAWING

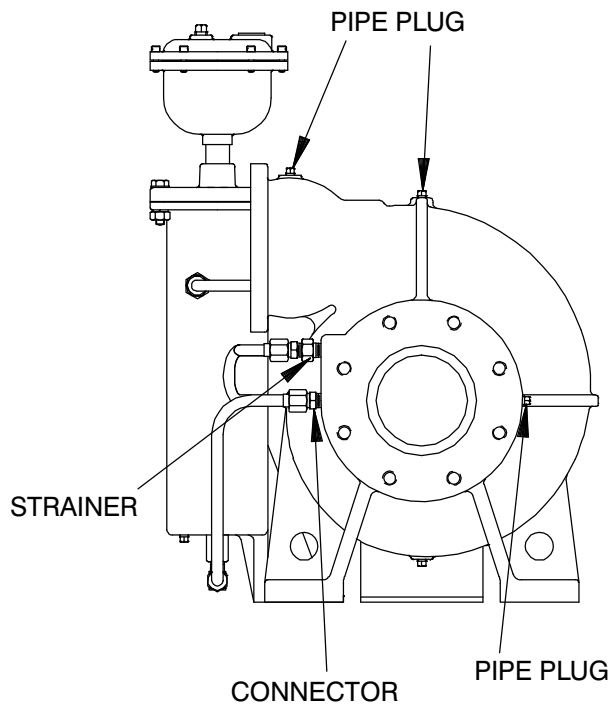
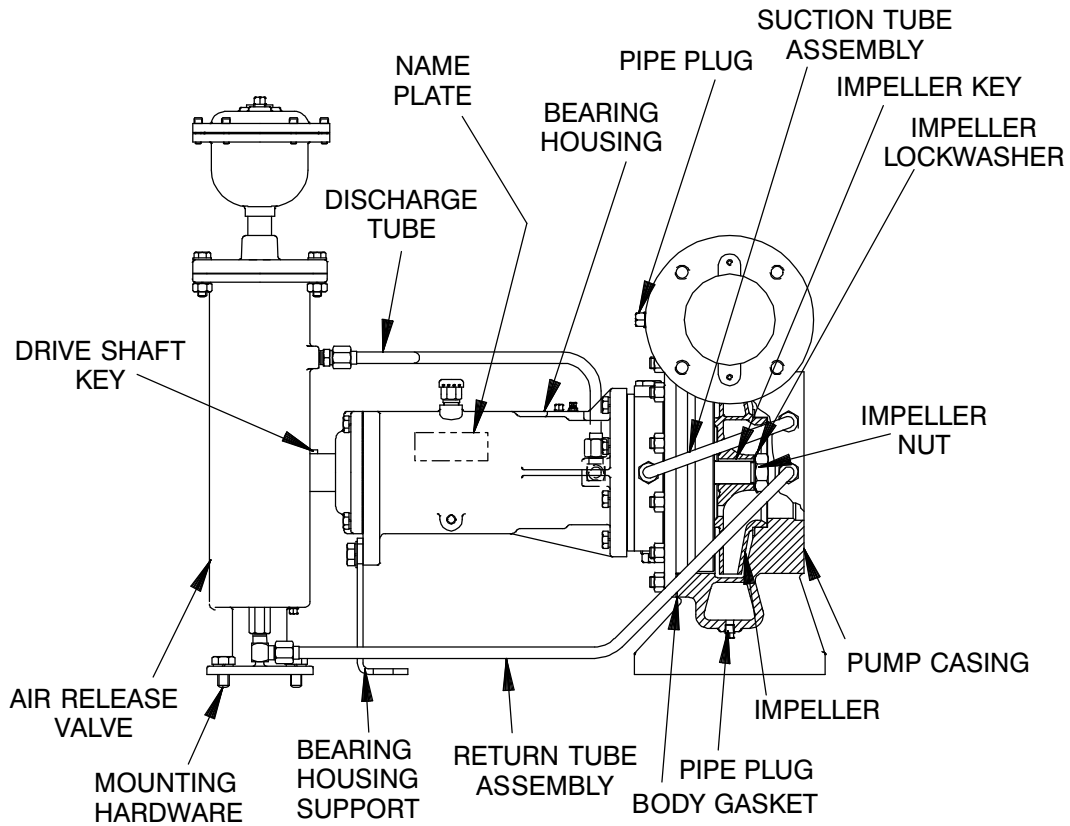

Figure 3. Typical RD Model Pump Assembly (“BAR” Version)

SECTION DRAWING

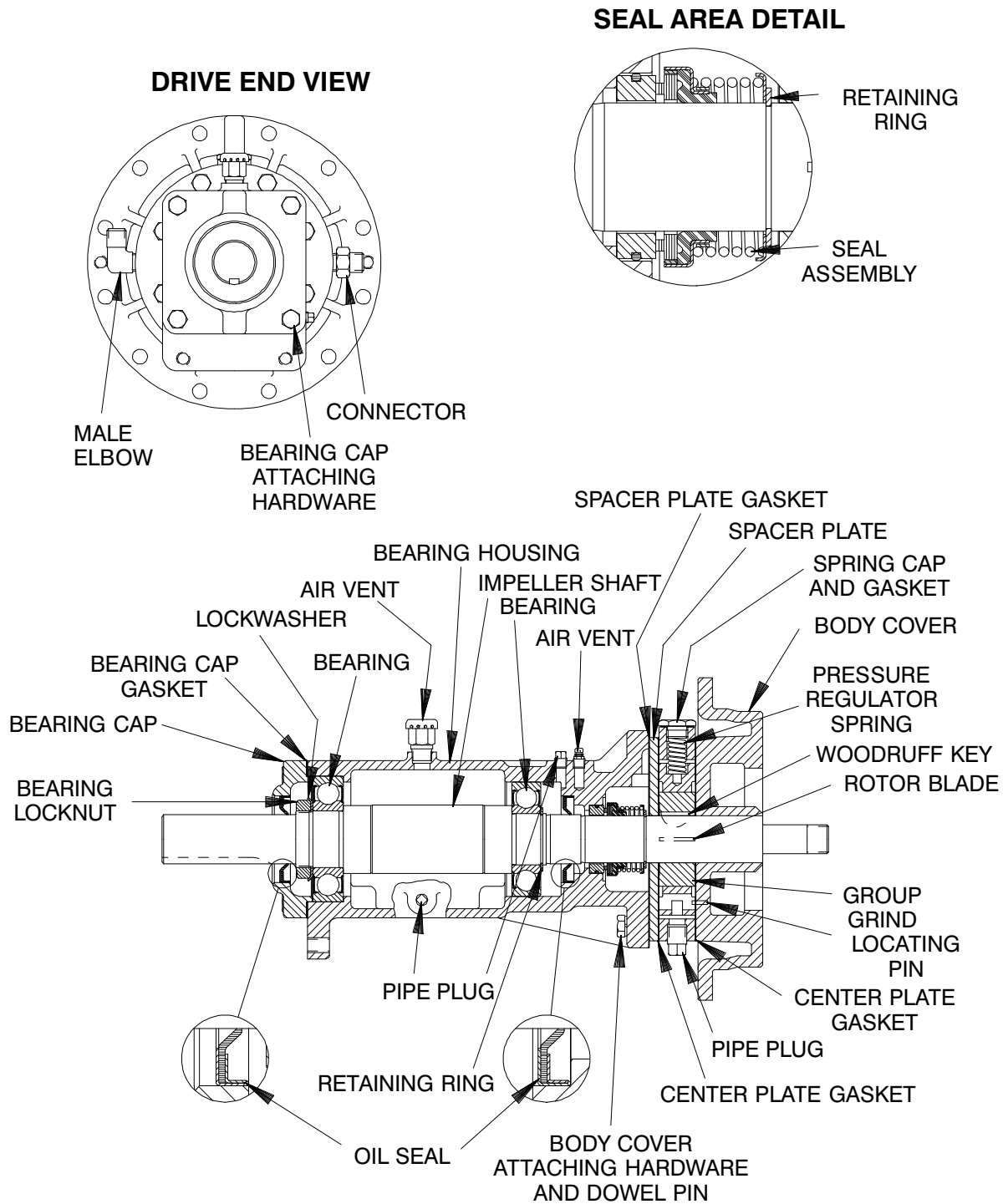

Figure 4. Typical RD Series Bearing Housing Assembly

SECTION DRAWING

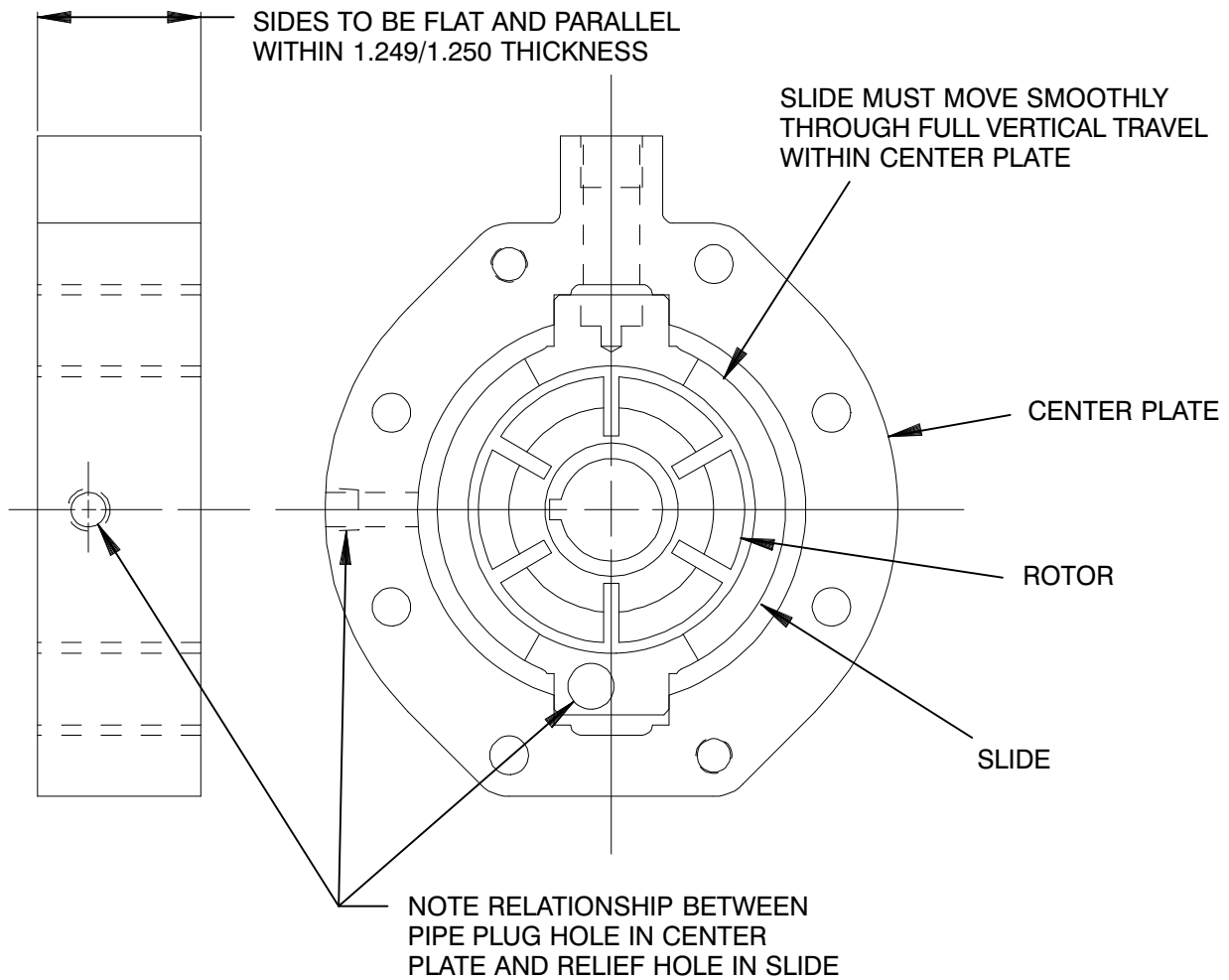

Figure 5. Typical Group Grind

PUMP AND SEAL DISASSEMBLY AND REASSEMBLY

Review all **SAFETY** information in Section A.

Follow the instructions on all tags, label and decals attached to the pump.

This pump requires little service due to its rugged, minimum-maintenance design. However, if it becomes necessary to inspect or replace the wearing parts, follow these instructions which are keyed to the sectional views (see Figures 1, 2, 3, 4 and 5). If your pump is equipped with an Air Release Valve Assembly ("BAR" Models), maintenance and repair instructions for the Air Release Valve are covered separately in the specific literature shipped with the unit.

As described on the following pages, this manual will alert personnel to known procedures which require special attention, to those which could damage equipment, and to those which could be dangerous to personnel. However, this manual cannot possibly anticipate and provide detailed precautions for every situation that might occur during maintenance of the unit. Therefore, it is the responsibility of the owner/maintenance personnel to ensure that **only** safe, established maintenance procedures are used, and that any procedures not addressed in this manual are performed **only** after establishing that neither personal safety nor pump integrity are compromised by such practices.

For part numbers, quantities, suction, discharge and return tube positioning for your specific pump, refer to pages E-2 thru E-5 .

All parts of this pump except the pump casing may be serviced without removing suction and discharge lines. However, the following instructions assume complete disassembly is required.

Before attempting to service the pump, shut off the incoming power to the motor and lock it out, or take other action to ensure that it will remain inoperative. Close all valves in the suction and discharge lines and drain the pump casing and group grind by removing the drain plugs. Clean and reinstall the drain plugs.



Before attempting to open or service the pump:

1. Familiarize yourself with this manual.
2. Shut off the incoming power to the motor and lock it out, or take other action to ensure that the pump will remain inoperative.
3. Allow the pump to completely cool if overheated.
4. Check the temperature before opening any covers, plates, or plugs.
5. Close the suction and discharge valves.
6. Vent the pump slowly and cautiously.
7. Drain the pump.



Do not attempt to service the pump assembly unless all power to the pump motor has been shut off and locked out, or other action taken to ensure that the pump will remain inoperative; otherwise, injury or death could result.



Death or serious personal injury and damage to the pump or components can occur if proper lifting procedures are not observed. Make certain that hoists, chains, slings or cables are in good working condition and of sufficient capacity and that they are positioned so that loads will be balanced and the pump or components will not be damaged when lifting. Suction and discharge hoses and piping **must** be removed from the pump before lifting. Lift

the pump or component only as high as necessary and keep personnel away from suspended objects.



This pump is designed to be used with volatile and/or flammable liquids. Be certain proper safety practices are followed before operating or servicing the pump. Provide adequate ventilation, prohibit smoking, wear static-resistant clothing and shoes. Clean up all fuel spills immediately after occurrence.



Use **Only Genuine Gorman-Rupp** replacement parts. Failure to do so may create a hazard and damage the pump or diminish optimal pump performance. Any such hazard, damage or diminished performance is not covered by the warranty.

NOTE

When appropriate recycling facilities are available, the user should recycle components and fluids when doing any routine maintenance / repairs and also at the end of the pump's useful life. All other components and fluids shall be disposed of according to all applicable codes and regulations.

Separating Pump From Motor

(Figure 1)

Remove the coupling guard and loosen the coupling on the pump drive shaft. Separate the motor and drive components from the pump, and remove the drive shaft key.

Air Release Valve Removal

(Figure 1)

Disconnect the air release valve discharge tube assembly from the bearing housing. Disconnect the return tube assembly from the pump casing.

If exterior venting tubing has been installed, disconnect the tubing at the air release valve. Remove the connecting hardware and remove the air release valve.

See the accompanying literature for individual parts, maintenance and repair of the Air Release Valve.

Pump Disassembly

(Figure 1 or 2)

Disconnect the suction and discharge tube assemblies from the bearing housing and pump casing.

Use a suitable hoist and sling to support the bearing housing. Remove the nuts securing the casing to the body cover (Figure 2 or 4). Install two jacking screws (RS Models, 3/8-16 UNC; RD Models, 1/2-13 UNC, not supplied) in the tapped holes in the body cover. Tighten the screws evenly to prevent binding, and pull the bearing housing, body cover and assembled parts straight out of the pump casing.

Impeller Removal

(Figure 2 or 4)

Immobilize the impeller by inserting a brass rod between the impeller vanes. **Be careful** not to damage the impeller vanes. Straighten the tabs on the impeller tabwasher, and remove the impeller nut and tabwasher.

Remove the brass rod. Install two 3/8-16 UNC capscrews (not supplied) in the tapped holes in the impeller, and use a suitable puller to remove the impeller from the shaft. Retain the impeller key.

NOTE

An alternate method of removing the impeller is to carefully pry on the back side of the impeller (directly against two opposing vanes) with equal pressure

until the impeller comes off the shaft.

Some impellers are fitted with wear rings. If the wear rings are badly worn, the entire impeller must be replaced or returned to the factory for wear ring replacement.

Group Grind Disassembly

(Figure 2 or 4)

Remove the spring cap, gasket and spring.



Most cleaning solvents are toxic and flammable. Use them only in a well ventilated area free from excessive heat, sparks, and flame. Read and follow all precautions printed on solvent containers.

Remove the body cover attaching hardware, and use a soft-faced mallet to tap around the outside diameter of the body cover until it separates from the bearing housing and group grind. Remove the outboard center plate gasket(s), and use solvent to clean the mating surfaces. **Be careful** not to scratch or mar the surfaces.

NOTE

*Use an ink marker to match mark the center plate, rotor and slide of the group grind assembly. These parts are ground as an assembly, and their relative locations **must** be maintained.*

If group grind replacement is necessary, slide the group grind assembly, blade spacers and rotor blades off the shaft. Retain the rotor woodruff key. Tap the group grind dowel pins out of the bearing housing.

Remove the inboard center plate gasket, spacer plate and spacer plate gasket. Clean any gasket adhesive from the mating surfaces using solvent. **Be careful** not to scratch or mar the surfaces.

Seal Removal

(Figure 2 or 4)

Remove the seal retaining ring with caution; tension on the seal spring will be released. Remove the spring centering washer. Slide the rotating portion of the seal off the shaft, and use a pair of stiff wires with hooked ends to remove the stationary seat. **Be careful** not to damage the seal faces.

If no further disassembly is required, see **Seal Installation**.

Shaft and Bearing Removal and Disassembly

(Figure 2 or 4)

When the pump is properly operated and maintained, the bearing housing should not require disassembly. Disassemble the shaft and bearings **only** when there is evidence of wear or damage.

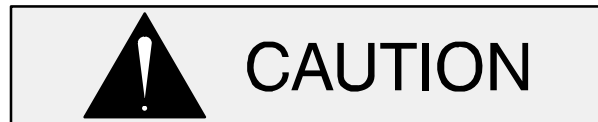

Shaft and bearing disassembly in the field is not recommended. These operations should be performed only in a properly equipped shop by qualified personnel.

There are no provisions for draining of flushing the bearing housing lubricant. Place a drip pan under the bearing housing before removing the shaft and bearings.

NOTE

If your pump is equipped with optional oil-lubricated bearings, remove the oil cup and drain the bearing cavity before removing the shaft and bearings.

Disengage the attaching hardware and remove the bearing cap and gasket. Use an arbor (or hydraulic) press to remove the oil seal from the bearing cap.

Place a block of wood against the impeller end of the shaft, and tap the shaft and assembled bearings from the bearing housing.

If your pump is equipped with an oil seal in the bearing housing between the bearing and seal

cavity, use a screwdriver or other suitable tool to remove the oil seal from the bearing housing.

After removing the shaft and bearings, clean and inspect the bearings **in place** as follows.

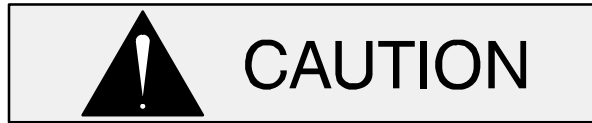

To prevent damage during removal from the shaft, it is recommended that bearings be cleaned and inspected **in place**. It is **strongly** recommended that the bearings be replaced **any** time the shaft and bearings are removed.

Clean the bearing housing, shaft and all component parts (except the bearings) with a soft cloth soaked in cleaning solvent. Inspect the parts for wear or damage and replace as necessary.



Most cleaning solvents are toxic and flammable. Use them only in a well ventilated area free from excessive heat, sparks, and flame. Read and follow all precautions printed on solvent containers.

Clean the bearings thoroughly in **fresh** cleaning solvent. Dry the bearings with filtered compressed air and coat with light oil.

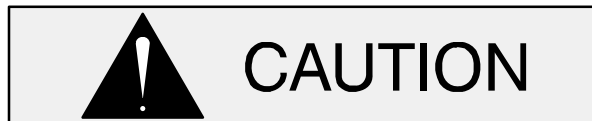

Bearings must be kept free of all dirt and foreign material. Failure to do so will greatly shorten bearing life. **Do not** spin dry bearings. This may scratch the balls or races and cause premature bearing failure.

Rotate the bearings by hand to check for roughness or binding and inspect the bearing balls. If rotation is rough or the bearing balls are discolored, replace the bearings.

The bearing tolerances provide a tight press fit onto the shaft and a snug slip fit into the bearing housing. Replace the bearings, shaft, or bearing housing if the proper bearing fit is not achieved.

If bearing replacement is required, remove the snap ring from the impeller shaft, and use a bearing puller to remove the inboard bearing from the shaft.

Straighten the tabs on the bearing washer and remove the bearing lock nut and washer. Use a bearing puller to remove the outboard bearing from the shaft.

Shaft and Bearing Reassembly and Installation (Figure 2 or 4)

Inspect the shaft for distortion, nicks or scratches, or for thread damage on the impeller end. Dress small nicks and burrs with a fine file or emery cloth. Replace the shaft if defective.



To prevent damage during removal from the shaft, it is recommended that bearings be cleaned and inspected **in place**. It is **strongly** recommended that the bearings be replaced **any** time the shaft and bearings are removed.

The bearings may be heated to ease installation. An induction heater, hot oil bath, electric oven, or hot plate may be used to heat the bearings. Bearings should **never** be heated with a direct flame or directly on a hot plate.

NOTE

*If a hot oil bath is used to heat the bearings, both the oil and the container must be **absolutely** clean. If the oil has been previously used, it must be **thoroughly** filtered.*



Use caution when handling hot bearings to prevent burns.

Heat the bearings to a uniform temperature **no higher than 250° F (120° C)**, and slide the bearings

onto the shaft, one at a time, until they are fully seated. This should be done quickly, in one continuous motion, to prevent the bearings from cooling and sticking on the shaft.

NOTE

*If optional oil-lubricated bearings are used, position the bearings on the shaft with the shielded sides facing **away** from each other. It is recommended that two buna or viton slinger rings (not supplied) be pressed onto the shaft between the bearings. Position the rings approximately 1/2 inch from each bearing to ensure sufficient lubrication and prevent premature bearing failure.*

After the bearings have been installed and allowed to cool, check to ensure that they have not moved away from the shaft shoulders in shrinking. If movement has occurred, use a suitable sized sleeve and a press to reposition the bearings against the shaft shoulders.

If heating the bearings is not practical, lubricate the bearings with light oil, and use a suitable sized sleeve, and an arbor (or hydraulic) press to install the bearings on the shaft.



When installing the bearings onto the shaft, **never** press or hit against the outer race, balls, or ball cage. Press **only** on the inner race.

Secure the inboard bearing on the shaft with the bearing retaining ring. Secure the outboard bearing with the tab washer and lock nut.

If your pump is equipped with an inboard oil seal (RD Model Pumps), lubricate the seal with light oil, and position it in the bearing housing with the lip positioned as shown in Figure 4. Press the oil seal into the bearing housing until fully seated.



When installing the shaft and bearings into the bearing bore, push against the outer race. **Never** hit the balls or ball cage.

Slide the shaft and assembled bearings into the bearing housing until the outboard bearing seats against the bearing housing shoulder. **Be careful** not to cut or roll the lip of the oil seal (RD Model Pumps).

Press the oil seal into the bearing cap with the lip positioned as shown in Figures 3 or 4. Replace the bearing cap gasket, and secure the bearing cap with the attaching hardware. **Be careful** not to cut the oil seal lip on the shaft keyway, or roll the lip during installation.

NOTE

*Impeller shaft endplay should be between .002 and .010 inch (.051 to .254 mm). Tighten the bearing cap hardware tight enough to prevent leakage and obtain the correct endplay. **Do not** over-tighten.*

Lubricate the bearing housing as indicated in **LUBRICATION**.

Seal Reassembly And Installation

(Figures 2 or 4 and 6)

Clean the seal cavity and shaft with a cloth soaked in fresh cleaning solvent.



Most cleaning solvents are toxic and flammable. Use them only in a well ventilated area free from excessive heat, sparks, and flame. Read and follow all precautions printed on solvent containers.

The seal is not normally reused because wear patterns on the finished faces cannot be realigned during reassembly. This could result in premature failure. If necessary to reuse an old seal in an emergency, **carefully** wash all metallic parts in **fresh** cleaning solvent and allow to dry thoroughly.

Handle the seal parts with extreme care to prevent damage. Be careful not to contaminate precision finished faces; even fingerprints on the faces can shorten seal life. If necessary, clean the faces with a non-oil based solvent and a clean, lint-free tissue. Wipe **lightly** in a concentric pattern to avoid scratching the faces.

Inspect the seal components for wear, scoring, grooves, and other damage that might cause leakage. If any components are worn, replace the complete seal; **never mix old and new seal parts.**

If a replacement seal is being used, remove it from the container and inspect the precision finished

faces to ensure that they are free of any foreign matter.

To ease installation of the seal, lubricate the shaft, bellows and stationary seat O-ring with water or a very **small** amount of oil, and apply a drop of light lubricating oil on the finished faces. Assemble the seal as follows, (see Figure 6).

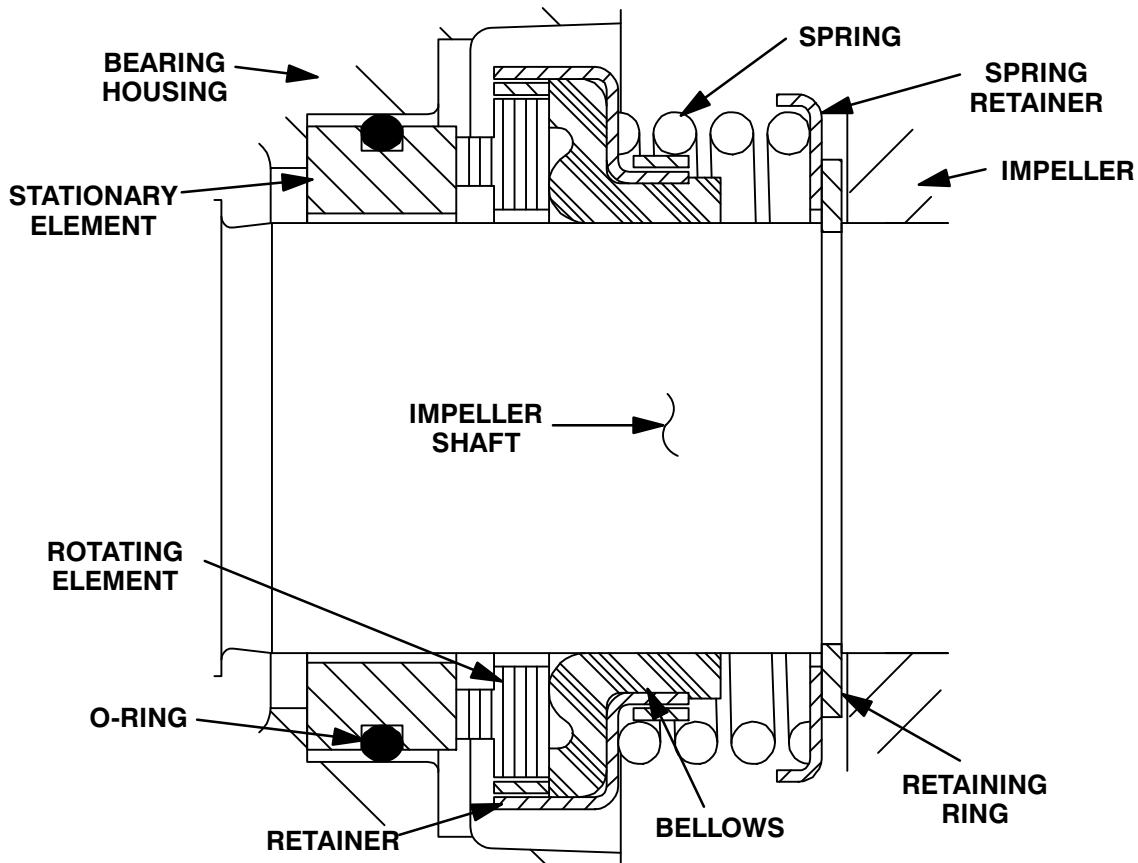

Figure 6. Seal Assembly



This seal is not designed for operation at temperatures above 160° F (71° C). Do not use at higher operating temperatures.

Inspect the impeller shaft for distortion, nicks, scratches, or damage to the shaft threads. Dress small nicks and burrs with a fine file or emery cloth. If the shaft is defective, refer to **Shaft and Bearing Removal and Disassembly** and replace the shaft.

Lubricate the O-ring with a light coat of oil and install it in the stationary seat. Press the seat and O-

ring into the bearing housing until fully seated. A push tube cut from a length of plastic pipe would aid this installation. The I.D. of the tube should be slightly larger than the O.D. of the shaft. Be careful not to damage the seal face. After installation, wipe the seal face in a concentric pattern with a clean, lint-free cloth.

NOTE

It is recommended that a tapered sleeve (see Figure 7) be installed over the shaft keyway to ease installation of the rotating portion of the seal. This tool can be made from steel tubing or black pipe.

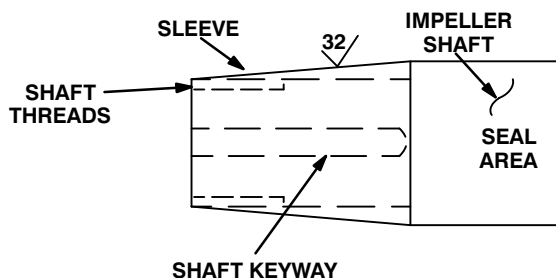

Figure 7. Seal Installation Sleeve

Lubricate the tapered sleeve and position it on the shaft. Position the rotating portion of the seal (consisting of the retainer, bellows and rotating element) on the sleeve, and apply even pressure against the shoulder of the seal retainer until the rotating subassembly slides onto the shaft and the seal faces contact. A push tube cut from a piece of plastic tubing would aid this installation. The I.D. of the tube should be approximately the same diameter as the I.D. of the seal spring.

Remove the tapered sleeve and install the seal spring and spring centering washer. Secure the seal with the retaining ring.

Group Grind Reassembly

NOTE

*If any component in the group grind assembly requires replacement, the entire group grind assembly must be replaced as a unit. Refer to the special instructions in **Group Grind Replacement** at this time.*

(Figure 2 or 5)

Install a new spacer plate gasket, the spacer plate and inboard center plate gasket. Be sure the oval hole in the spacer plate matches up with the tubing hole.

Inspect the group grind rotor (Figure 5) for wear or damage. If replacement is necessary, refer to the specific instructions in **Group Grind Replacement**. If the group grind is not being replaced, proceed as follows.

Center the inboard blade spacer on the shaft (RS Models only) and install the rotor woodruff key.

(Figure 5)

If removed, install the dowel pins in the bearing housing. Install the center plate, and install the slide in the center plate, making sure the recessed hole in the slide faces toward the impeller. Check for free movement of the slide in the center plate.

Coat both ends of the rotor with "Anti-Wear Lubricating And Hydraulic Oil SAE 10, Energol HLP-HD 32" or equivalent lubricant, and install it on the shaft. Check the rotor for free movement.

(Figure 2 or 5)

Inspect the rotor blades for wear or damage and replace as required. Align the blades with the rotor slots and install the blades. Install the outboard blade spacer on the rotor (RS Models only).

Install one outboard center plate gasket.

NOTE

If the thickness of the rotor or slide is greater than the thickness of the center plate, install a second center plate gasket. To check thickness, temporarily secure the center plate by installing two 7/16-20 UNC by 2-inch long bolts (not supplied) through the bearing housing and spacer plate, and into the tapped holes in the center plate. Place a straight edge across the center plate and rotate the shaft. If the rotor or blades touch the straight edge at any point, add a second center plate gasket and re-check. The clearance should be no more than .001 inch (0,025 mm) from the rotor to the straight edge. No more than two gaskets should be required. Remove the temporary bolts.

Inspect the locating pin and replace it if required. Align the pin in the recessed hole in the slide, and use a soft-faced mallet to tap the body cover into place on the dowel pins. Secure the body cover with the attaching hardware. Be sure the dowel pins are fully seated into the body cover.

Group Grind Check

(Figure 2 or 5)

Remove the spring cap and pressure regulating spring. Insert a screwdriver or other suitable tool into the drain plug hole, and move the slide up and down. The slide should travel 1/8 inch (3,2 mm)

from the full priming position to the neutral position. If it does not, flush the group grind with penetrating oil, and check the slide travel again. The slide should move freely.

After checking the group grind, install the pressure regulating spring, spring cap gasket and spring cap. Clean and reinstall the drain plug.

Refer to **Impeller Installation**.

Group Grind Replacement

(Figure 2 or 4)

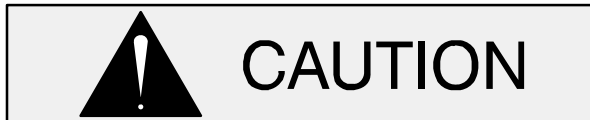

If the group grind requires replacement, it is **strongly** recommended that the pump be returned to the factory. Fitting procedures involve extremely close tolerances which are critical to efficient operation. These procedures are difficult to accomplish outside the factory.

If the group grind **must** be replaced in the field, dowel holes in the center plate must be drilled and reamed after the group grind, body cover and impeller have been fully reassembled.

Install the spacer plate gaskets, spacer plate, blade spacers (RS Models only), and group grind parts (including the outboard blade spacer, RS Models only) as described in **Group Grind Installation**.

Before installing the body cover, position the group grind slide in full priming position (in contact with the bottom of the center plate). To check rotor concentricity, rotate the shaft until the highest point on the rotor comes in contact with the slide. Move the center plate and slide until a .002 inch (0,05 mm) feeler gauge can be inserted between the rotor and slide at the point of contact. Secure the center plate in this position with two 7/16-20 UNF by 2 inch long capscrews (not supplied) inserted through the bearing housing and into the tapped holes in the center plate.

NOTE

*The pressure regulating spring **must** be removed*

during this procedure; otherwise, spring tension on the slide could cock the assembly and prevent accurate measurements.

Remove the feeler gauge and install one outboard center plate gasket.

NOTE

If the thickness of the rotor or slide is greater than the thickness of the center plate, install a second center plate gasket. To check thickness, place a straight edge across the center plate and rotate the shaft. If the rotor or blades touch the straight edge at any point, add a second center plate gasket and re-check. The clearance should be no more than .001 inch (0,025 mm) from the rotor to the straight edge. No more than two gaskets should be required. Remove the temporary bolts.

Inspect the locating pin and replace it if required. Align the pin in the recessed hole in the slide, and position the body cover on the shaft. **Be careful** not do disturb the position of the center plate. Secure the body cover with the hardware, but **do not** fully tighten the capscrews at this time.

Install the impeller as described in **Impeller Installation**. **Do not** bend the tabs over on the impeller washer (Figure 1 or 2) until the shaft is rotated to check for rubbing of the impeller or inboard impeller wear ring (if so equipped) against the body cover. If the impeller or wear ring (if so equipped) rubs, tap the body cover with a mallet until the impeller rotates freely. Now tighten the hardware securing the body cover.

NOTE

Fully tighten six of the capscrews before replacing the two capscrews used to temporarily hold the group grind.

After fully securing the body cover, bend the tabs of the impeller washer over the impeller nut.

Measure the length of the dowel pins. Use the existing dowel pin holes in the bearing housing as guides to drill and ream two new dowel pin holes (.312 inch [7,9 mm] finished diameter) through the center plate. The holes should be just deep enough so the pins will be **flush** with the bearing housing when installed. **Do not** drill through the

body cover. Be careful not to damage the holes in the bearing housing or body cover with the drill bit or reamer. Instal the dowel pins in the new holes.

Group Grind Check

(Figure 2 or 4)

Remove the spring cap and pressure regulating spring. Insert a screwdriver or other suitable tool into the drain plug hole, and move the slide up and down. The slide should travel 1/8 inch (3,2 mm) from the full priming position to the neutral position. If it does not, flush the group grind with penetrating oil, and check the slide travel again. The slide should move freely. Reinstall the pressure regulating spring and spring cap, and clean and reinstall the drain plug.

After checking the group grind, install the pressure regulating spring, spring cap gasket and spring cap.

Refer to **Impeller Installation**.

Impeller Installation

(Figure 1 or 2)

Inspect the impeller and replace it if cracked or badly worn. Some impellers are equipped with wear rings. If the wear rings that are badly worn, the entire impeller must be replaced or returned to the factory for wear ring replacement.

Install the impeller key, and slide the impeller onto the shaft. Immobilize the impeller, and secure it with the tab washer and impeller nut. Bend the tabs on the washer over the impeller nut.

Before operation, lubricate the group grind as indicated in **LUBRICATION**.

Pump Reassembly

(Figure 1 or 2)

Install the pump casing gasket. Install the bearing housing assembly in the pump casing, and secure it with the attaching hardware.

Final Assembly

(Figure 1 or 2)

Connect the suction and discharge tube assemblies to the bearing housing and pump casing. For part numbers, quantities, suction, discharge and return tube positioning for your specific pump, refer to the separate Parts List manual accompanying your pump.

Install the drive shaft key, and connect the coupling and motor. Install the coupling guards.

Air Release Valve Installation

(Figure 2)

Secure the air release valve with the mounting hardware. Connect the return tube assembly to the pump casing.

LUBRICATION

Seal Assembly

The seal assembly is lubricated by the medium being pumped. No additional lubrication is required.

Group Grind

Before starting the pump for the first time or if the pump has not been used for a long period of time, remove the 1/8-inch NPT pipe plug (located in the bearing housing, above the seal area when viewed from the drive end). Pour approximately 8 ounces (0,24 liter) of SAE 10 or 20 non-detergent oil into the housing to lubricate the shaft seal and group grind rotor blades. Reinstall the plug.

Standard Bearings

(Figure 2 or 4)

Standard bearings used in this pump are permanently sealed and lubricated by the manufacturer, and no additional lubrication is required. However, to minimize the danger of moisture contamination due to temperature changes, the bearing housing is also partially filled with grease.

When overhauling the bearing housing, remove the air vent fitting, install a lubrication fitting, and fill

the cavity with approximately 15 ounces (425 g) of grease (approximately one-third full).

Optional Oil Lubricated Bearings

The bearing housing was fully lubricated when shipped from the factory. Check the oil level regularly at the oil cup and maintain it at the top of the cup. When lubrication is required, remove the air vent and add SAE No. 30 non-detergent oil through the hole. **Do not** over-lubricate. Over-lubrication can cause the bearings to over-heat, resulting in premature bearing failure.

Under normal conditions, drain the bearing housing once each year and refill with clean oil. Change

the oil more frequently if the pump is operated continuously or installed in an environment with rapid temperature change.



Monitor the condition of the gearbox lubricant regularly for evidence of rust or moisture condensation. This is especially important in areas where variable hot and cold temperatures are common.

For cold weather operation, consult the factory or a lubricant supplier for the recommended grade of oil.

**For Warranty Information, Please Visit
www.grpumps.com/warranty
or call:
U.S.: 419-755-1280
Canada: 519-631-2870
International: +1-419-755-1352**

GORMAN-RUPP PUMPS