**INSTALLATION, OPERATION,
AND MAINTENANCE MANUAL
WITH PARTS LIST**



**SUPER T SERIES®
ENVIRONMENTAL SILENT PUMP**

MODEL

T6A60S-ZPP857-ESP

GORMAN-RUPP PUMPS

www.grpumps.com

Register your new
Gorman-Rupp pump online at
www.grpumps.com

Valid serial number and e-mail address required.

RECORD YOUR PUMP MODEL AND SERIAL NUMBER

Please record your pump model and serial number in the spaces provided below. Your Gorman-Rupp distributor needs this information when you require parts or service.

Pump Model: _____

Serial Number: _____

TABLE OF CONTENTS

INTRODUCTION	PAGE I – 1
SAFETY - SECTION A	PAGE A – 1
INSTALLATION – SECTION B	PAGE B – 1
Pump Dimensions	PAGE B – 1
PREINSTALLATION INSPECTION	PAGE B – 1
Battery Specifications And Installation	PAGE B – 2
SAFETY AND CONFORMANCE	PAGE B – 2
POSITIONING PUMP	PAGE B – 3
Lifting	PAGE B – 3
Mounting	PAGE B – 3
Clearance	PAGE B – 3
NATURAL GAS FUEL	PAGE B – 3
LPG FUEL	PAGE B – 3
FUEL TANK (LPG ONLY)	PAGE B – 4
REGULATORS (NATURAL GAS)	PAGE B – 4
REGULATORS (LP GAS)	PAGE B – 4
CONNECTING FUEL SUPPLY LINE TO THE UNIT	PAGE B – 5
CHANGING FUEL TYPE	PAGE B – 5
SUCTION AND DISCHARGE PIPING	PAGE B – 5
Materials	PAGE B – 5
Line Configuration	PAGE B – 5
Connections to Pump	PAGE B – 5
Gauges	PAGE B – 5
SUCTION LINES	PAGE B – 6
Fittings	PAGE B – 6
Strainers	PAGE B – 6
Sealing	PAGE B – 6
Suction Lines In Sumps	PAGE B – 6
Suction Line Positioning	PAGE B – 6
SUBMERSIBLE TRANSDUCER	PAGE B – 7
DISCHARGE LINES	PAGE B – 8
Siphoning	PAGE B – 8
Valves	PAGE B – 8
OPERATION – SECTION C	PAGE C – 1
OPERATION	PAGE C – 1
STARTING	PAGE C – 1
PRIMING	PAGE C – 1
OPTIONAL EPS CONTROL	PAGE C – 2
Features	PAGE C – 2
Functional Description	PAGE C – 2
EPS Functions	PAGE C – 3
EPS Calibration	PAGE C – 4
Zero Adjustment	PAGE C – 4
Span Adjustment	PAGE C – 4
Level Adjustment	PAGE C – 4

TABLE OF CONTENTS
(continued)

Horn Delay	PAGE C – 4
ROUTINE OPERATION	PAGE C – 4
Lines With a Bypass	PAGE C – 5
Lines Without a Bypass	PAGE C – 5
OPERATION IN EXTREME HEAT	PAGE C – 5
OPERATIONAL CHECKS	PAGE C – 5
Leakage	PAGE C – 5
Pump Vacuum Check	PAGE C – 5
Liquid Temperature And Overheating	PAGE C – 5
Strainer Check	PAGE C – 6
STOPPING	PAGE C – 6
Manual Stopping	PAGE C – 6
Automatic Stopping	PAGE C – 6
Safety Shutdown System	PAGE C – 6
PERIODIC CHECKS	PAGE C – 6
Seal Cavity and Bearing Lubrication	PAGE C – 6
Bearing Temperature Check	PAGE C – 6
Engine Fuel Filter	PAGE C – 7
Engine Oil	PAGE C – 7
COLD WEATHER PRESERVATION	PAGE C – 7
TROUBLESHOOTING – SECTION D	PAGE D – 1
PREVENTIVE MAINTENANCE	PAGE D – 3
PUMP MAINTENANCE AND REPAIR - SECTION E	PAGE E – 1
STANDARD PERFORMANCE CURVE	PAGE E – 1
PARTS LISTS:	
Pump Model	PAGE E – 3
Pump Model (Cont'd)	PAGE E – 5
Pump End Assembly	PAGE E – 7
Repair Rotating Assembly	PAGE E – 9
Coupling Kit	PAGE E – 10
PUMP AND SEAL DISASSEMBLY AND REASSEMBLY	PAGE E – 11
Back Cover And Wear Plate Removal	PAGE E – 12
Suction Check Valve Removal	PAGE E – 12
Separating Intermediate and Coupling Kit From Engine	PAGE E – 12
Loosening Impeller	PAGE E – 13
Rotating Assembly Removal	PAGE E – 13
Impeller Removal	PAGE E – 14
Seal Removal	PAGE E – 14
Shaft and Bearing Removal and Disassembly	PAGE E – 14
Shaft and Bearing Reassembly and Installation	PAGE E – 15
Seal Installation	PAGE E – 16
Impeller Installation and Adjustment	PAGE E – 19
Rotating Assembly Installation	PAGE E – 19
Suction Check Valve Installation	PAGE E – 19
Back Cover Installation And Adjustment	PAGE E – 20
Securing Pump and Coupling Kit to Engine	PAGE E – 21
PRESSURE RELIEF VALVE MAINTENANCE	PAGE E – 21
Final Pump Assembly	PAGE E – 22

TABLE OF CONTENTS
(continued)

LUBRICATION	PAGE E – 22
Seal Assembly	PAGE E – 22
Bearings	PAGE E – 22
Engine	PAGE E – 22

INTRODUCTION

Thank You for purchasing a Gorman-Rupp pump. **Read this manual** carefully to learn how to safely install and operate your pump. Failure to do so could result in personal injury or damage to the pump.

Because pump installations are seldom identical, this manual cannot possibly provide detailed instructions and precautions for every aspect of each specific application. Therefore, it is the responsibility of the owner/installer of the pump to ensure that applications not addressed in this manual are performed **only** after establishing that neither operator safety nor pump integrity are compromised by the installation. Pumps and related equipment **must** be installed and operated according to all national, local and industry standards.

If there are any questions regarding the pump or its application which are not covered in this manual or in other literature accompanying this unit, please contact your Gorman-Rupp distributor, or The Gorman-Rupp Company:

The Gorman-Rupp Company
P.O. Box 1217
Mansfield, Ohio 44901-1217
Phone: (419) 755-1011
 or:
Gorman-Rupp of Canada Limited
70 Burwell Road
St. Thomas, Ontario N5P 3R7
Phone: (519) 631-2870

For information or technical assistance on the power source, contact the power source manufacturer's local dealer or representative.

HAZARD AND INSTRUCTION DEFINITIONS

The following are used to alert maintenance personnel to procedures which require special attention, to those which could damage equipment, and to those which could be dangerous to personnel:



Immediate hazards which WILL result in severe personal injury or death. These instructions describe the procedure required and the injury which will result from failure to follow the procedure.



Hazards or unsafe practices which COULD result in severe personal injury or death. These instructions describe the procedure required and the injury which could result from failure to follow the procedure.



Hazards or unsafe practices which COULD result in minor personal injury or product or property damage. These instructions describe the requirements and the possible damage which could result from failure to follow the procedure.

NOTE

Instructions to aid in installation, operation, and maintenance or which clarify a procedure.

SAFETY - SECTION A

This information applies to Super T Series® engine driven pumps. Refer to the manual accompanying the engine before attempting to begin operation.

Because pump installations are seldom identical, this manual cannot possibly provide detailed instructions and precautions for each specific application. Therefore, it is the owner/installer's responsibility to ensure that applications not addressed in this manual are performed only after establishing that neither operator safety nor pump integrity are compromised by the installation.



Before attempting to open or service the pump:

1. Familiarize yourself with this manual.
2. Shut down the engine, remove the key and disconnect the positive battery cable to ensure that the pump will remain inoperative.
3. Allow the pump to completely cool if overheated.
4. Check the temperature before opening any covers, plates, or plugs.
5. Close the suction and discharge valves.
6. Vent the pump slowly and cautiously.
7. Drain the pump.



This pump is equipped with an automatic starting system, and is subject to automatic restart. Keep hands and clothing away from the unit to prevent injury during automatic operation. Disconnect

the positive battery cable before performing any maintenance. Failure to do so may result in serious personal injury.



This pump is designed to handle dirty water containing specified entrained solids. Do not attempt to pump volatile, corrosive, or flammable liquids which may damage the pump or endanger personnel as a result of pump failure.



Death or serious personal injury and damage to the pump or components can occur if proper lifting procedures are not observed. Make certain that hoists, chains, slings or cables are in good working condition and of sufficient capacity and that they are positioned so that loads will be balanced and the pump or components will not be damaged when lifting. Suction and discharge hoses and piping must be removed from the pump before lifting. Lift the pump or component only as high as necessary and keep personnel away from suspended objects.



After the unit has been installed, make certain that the pump and all piping or hose connections are tight, properly supported and secure before operation.



Do not operate the pump against a closed discharge valve for long periods

of time. If operated against a closed discharge valve, pump components will deteriorate, and the liquid could come to a boil, build pressure, and cause the pump casing to rupture or explode.



Do not remove plates, covers, gauges, pipe plugs, or fittings from an overheated pump. Vapor pressure within the pump can cause parts being disengaged to be ejected with great force. Allow the pump to cool before servicing.



Do not operate an internal combustion engine in an explosive atmosphere. When operating internal combustion engines in an enclosed area, make certain that exhaust fumes are piped to the outside. These fumes contain carbon monoxide, a deadly gas that is colorless, tasteless, and odorless.



Natural gas presents an extreme explosion and fire hazard. Follow all safety

precautions outlined by the National Fire Protection Association when designing and installing the system. Make certain that the regulators and fuel lines are of the proper size and capacity for the system, and that all fuel lines are securely connected and free of leaks.



Fuel used by internal combustion engines presents an extreme explosion and fire hazard. Make certain that all fuel lines are securely connected and free of leaks.



Never tamper with the governor to gain more power. The governor establishes safe operating limits that should not be exceeded. Refer to the performance curve in Section E for the maximum continuous operating speed for this pump.

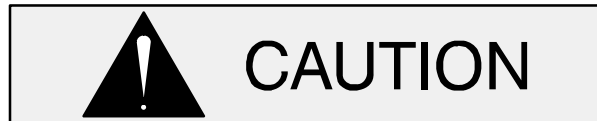

Pumps and related equipment must be installed and operated according to all national, local and industry standards.

INSTALLATION – SECTION B

Review all SAFETY information in Section A.

Since pump installations are seldom identical, this section offers only general recommendations and practices required to inspect, position, and arrange the pump and piping.

Most of the information pertains to a standard **static lift** application where the pump is positioned above the free level of liquid to be pumped.

If installed in a **flooded suction application** where the liquid is supplied to the pump under pressure, some of the information such as mounting, line configuration, and priming must be tailored to the

specific application. Since the pressure supplied to the pump is critical to performance and safety, **be sure** to limit the incoming pressure to 50% of the maximum permissible operating pressure as shown on the pump performance curve.

For further assistance, contact your Gorman-Rupp distributor or the Gorman-Rupp Company.

Pump Dimensions

See Figure 1 for the approximate physical dimensions of this pump.

OUTLINE DRAWING

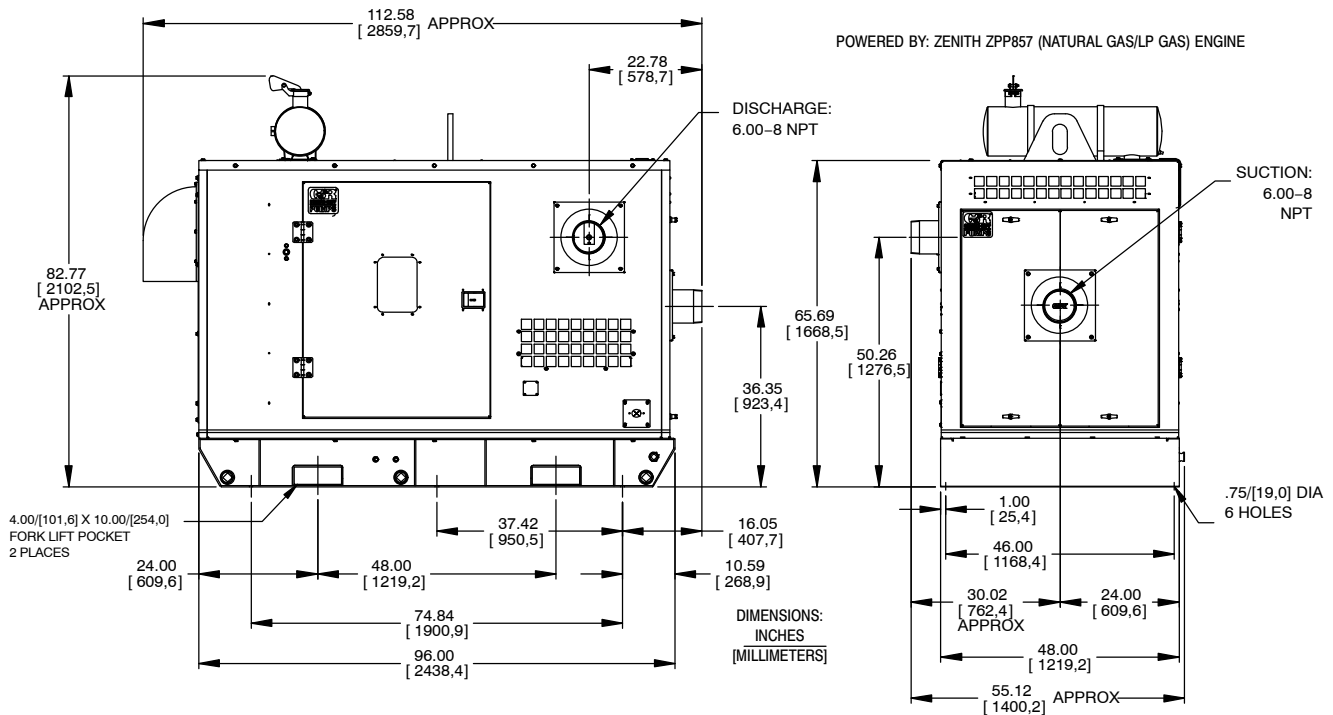

Figure 1. Pump Model T6A60S-ZPP857-ESP

PREINSTALLATION INSPECTION

The pump assembly was inspected and tested before shipment from the factory. Before installation, inspect the pump for damage which may have occurred during shipment. Check as follows:

- Inspect the pump assembly for cracks, dents, damaged threads, and other obvious damage.
- Check for and tighten loose attaching hardware. Since gaskets tend to shrink after dry-

ing, check for loose hardware at mating surfaces.

- c. Carefully read all tags, decals, and markings on the pump assembly, and perform all duties indicated.
- d. Check levels and lubricate as necessary. Refer to **LUBRICATION** in the **MAINTENANCE AND REPAIR** section of this manual and perform duties as instructed.
- e. If the pump and engine have been stored for more than 12 months, some of the components or lubricants may have exceeded their maximum shelf life. These **must be inspected or replaced** to ensure maximum pump service.

If the maximum shelf life has been exceeded, or if anything appears to be abnormal, contact your Gorman-Rupp distributor or the factory to determine the repair or updating policy. **Do not** put the pump into service until appropriate action has been taken.

Battery Specifications And Installation

Unless otherwise specified on the pump order, the engine battery was **not** included with the unit. Refer to the following specifications when selecting a battery.

Table 1. Battery Specifications

Voltage	Cold Crank Amps @ 0° F	Reserve Capacity @ 80° F (Minutes)	Amp/ Hr. Rating	Approx. Overall Dims. (Inches)
12 Volts	950	175	95	13L x 7W x 9.5H

Before installing the battery, clean the positive and negative cable connectors, and the battery terminals. Secure the battery by tightening the holddown brackets. The terminals and clamps may be coated with petroleum jelly to retard corro-

sion. Connect and tighten the positive cable first, then the negative cable.

SAFETY AND CONFORMANCE

All aspects of the design and installation of the fuel supply system must be evaluated in terms of safety to personnel and equipment, and conformance to all applicable codes.

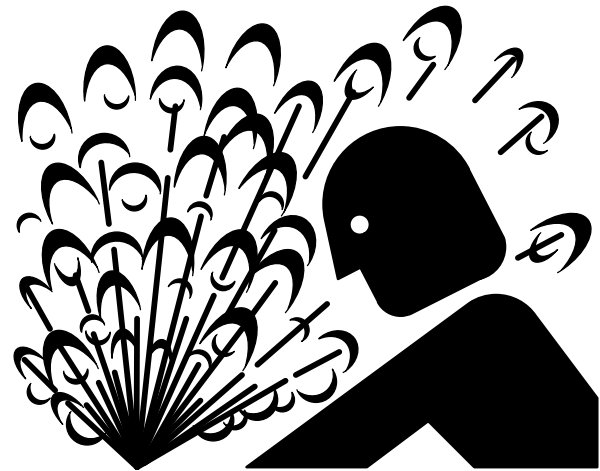

Natural Gas and Liquefied Petroleum Gas (LPG) presents an extreme explosion and fire hazard. Follow all safety precautions outlined by the National Fire Protection Association when designing and installing the system. Make certain that the regulators and fuel lines are of the proper size and capacity for the system, and that all fuel lines are securely connected and free of leaks.

Before installing the system:

1. Check all state and local codes pertaining to installations of stationary combustion engines and fuel systems.
2. Consult the following National Fire Protection Association pamphlet:

NFPA No. 37 – Stationary Combustion Engines/Gas Turbines

NFPA No. 54 – National Fuel Gas Code Handbook.

NFPA No. 37 – Liquefied Petroleum Gas Storage and Handling.

Copies may be ordered from:

National Fire Protection Association
1 Batterymarch Park
Quincy, Massachusetts 02269

POSITIONING PUMP

Lifting



Death or serious personal injury and damage to the pump or components can occur if proper lifting procedures are not observed. Make certain that hoists, chains, slings or cables are in good working condition and of sufficient capacity and that they are positioned so that loads will be balanced and the pump or components will not be damaged when lifting. Suction and discharge hoses and piping must be removed from the pump before lifting. Lift the pump or component only as high as necessary and keep personnel away from suspended objects.

Pump unit weights will vary depending on the mounting and drive provided. Check the shipping tag on the unit packaging for the actual weight, and use lifting equipment with appropriate capacity. Drain the pump and remove all customer-installed equipment such as suction and discharge hoses or piping before attempting to lift existing, installed units.

Mounting

Locate the pump in an accessible place as close as practical to the liquid being pumped. Level mounting is essential for proper operation.

The pump may have to be supported or shimmed to provide for level operation or to eliminate vibration.

To ensure sufficient lubrication to the engine, **do not** position the pump and engine more than 15° off horizontal for continuous operation. The pump and engine may be positioned up to 30° off horizontal for **intermittent operation only**; however, the engine manufacturer should be consulted for continuous operation at angles greater than 15°.

Clearance

When positioning the pump, allow a minimum clearance of **18 inches (457,2 mm)** in front of the enclosure suction cover to permit removal of the cover and easy access to the pump.

NATURAL GAS FUEL

The amount of natural gas fuel required for the engine is measured in cubic feet per hour. This is calculated from the BTU (British Thermal Unit) content of the natural gas supplied, and the horsepower required to drive the pump. **This unit requires 1,141 CF/hr of natural gas with 1000 BTU content at 10 inches of water column.** The BTU content of gas varies in the United States, therefore, it will be necessary to contact your local gas supplier to determine the BTU content of the natural gas in your area.

When burning natural gas having a BTU content of 1000 or over, the engine will deliver the rated horsepower as shown on the pump Specification Data Sheet. On lower grade natural gas, there will be a power loss of approximately 3% for each 100 BTU under 1000.

Natural gas pressures provided by suppliers vary, so in order to provide the optimal gas supply to the engine, Gorman-Rupp has provided a regulator with the unit that can be adjusted to provide 10 inches of water column of gas pressure to the engine. Install the pressure regulator supplied with the unit in the line supplying the engine, then check and adjust the fuel pressure as described in **CONNECTING FUEL SUPPLY LINE TO THE UNIT.**

LPG FUEL

The term Liquefied Petroleum Gas (LPG) refers to any one of many butane/propane compounds, some of which have additives for specific applications. Commercial grade propane is recommended.

FUEL TANK (LPG ONLY)

The amount of LPG fuel required for the engine is measured in BTU (British Thermal Unit) per hour. **This unit requires 1,142,038 BTU/hr of LPG fuel at 10 inches of water column.**

The amount of fuel which must be stored at the installation will be determined by the length of time the engine must operate before refueling is necessary. Engine operating time is predicted on system characteristics such as flow rates, pump capacity, anticipated number and duration of power failures in a given time period, programmed engine exercise periods, etc.

On LPG fuel systems, fuel consumption is measured in British Thermal Units per Hour (BTU/HR). This rate of consumption will vary according to engine speed and load. For purposes of determining BTU consumption, assume that all engine operating time will be at full load and at the speed required for rated pumping capacity. (Engine speed is shown on the performance curve on the Gorman-Rupp Specification Data Sheet for the pump). Short periods of idle speed time need not be considered, as fuel consumption at idle is negligible. If extended periods of idle speed time are anticipated, calculated fuel consumption should be increased accordingly.

Consult the local LPG supplier to determine the size of fuel tank required. This determination will be based on the BTU/HR consumption rate, total BTU storage required, local climate conditions, BTU content of the fuel to be supplied, and installation parameters such as local code restrictions and proposed tank location.

On all units, be sure to specify that the tank will be used for vapor withdrawal. In this type of system, fuel is taken from the top of the storage tank in the vapor state, eliminating the need for a LP gas converter, which converts liquid fuel to the vapor required by the engine fuel mixer. The vapor withdrawal system provides an adequate amount of fuel for an engine the size of which is on the pump unit. However, if fuel is used at a rate excessive for the tank size and ambient temperature conditions, freezing may occur in the tank. This problem can usually be anticipated by the LPG supplier and may require selection of a larger tank.

REGULATORS (NATURAL GAS)

The engine is equipped with a natural gas regulator designed to supply the engine with natural gas at 6 inches of water column.

Gorman-Rupp has provided a secondary natural gas regulator. This regulator has a maximum inlet pressure of 15 psi (1,0 bar) and an outlet pressure range of 6 to 14 inches (152 to 356 mm) water column. This regulator can be used to supply the 10 inches (254 mm) the engine requires when the gas supplier can only supply a pressure greater than 0.5 psi (0,03 bar). The regulator is shipped loose for field installation and should be located before any fuel lock-off valves in the gas supply line.

REGULATORS (LP GAS)

The engine is equipped with an LP gas regulator designed to supply the engine with LP gas at 6 inches of water column. Gorman-Rupp provides a primary regulator and a secondary regulator with the pump unit.

The pressure in an LPG storage tank with vapor withdrawal will vary depending on temperature. For example, the pressure of propane at 70°F (21°C) is approximately 100 psi (6,9 bar), but this pressure increases to 180 psi (12,4 bar) at 100°F (38°C) and decreases to 18 psi (1,2 bar) at 10°F (-23°C). The primary (first stage) regulator is capable of accepting this wide range of inlet pressures while maintaining approximately 10 psi outlet pressure (see the note below) and should be located on or near the storage tank. The secondary (second stage) regulator then reduces this 10 psi (0,6 bar) pressure at its inlet to an outlet pressure of 10 inches of water column (see the note below). This regulator should be located before any fuel lock-off valve in the supply line. If this regulator is located after a fuel lock-off valve the operation of the regulator will be affected by sudden pressure increase when the lock-off valve opens. The regulators are sized to deliver the fuel flow required by the engine during full load operation while maintaining pressures within specified limits.

NOTE

The primary regulator output pressure of 10 psi (0,7 bar) is used to illustrate a typical system. Actual pressure may be higher or lower depending on code requirements. The primary regulator supplied

with the pumping unit has a range of 8 psi to 12 psi (0,5 to 0,8 bar).

The secondary regulator output pressure of 10 inches of water column is used to illustrate a typical system. Actual pressure may be higher or lower depending on code requirements. The secondary regulator supplied with the pumping unit has a range of 4 inches to 12 inches (102mm to 305mm) of water column.

CONNECTING FUEL SUPPLY LINE TO THE UNIT

There is a 1-inch pipe connection on the outside of the enclosure for connecting the incoming gas supply line. Inside the enclosure, there is a 1-inch pipe tee in the engine fuel line. The tee is equipped with a reducer and a 1/4-inch pipe plug. Remove the pipe plug and install a pressure gauge rated in inches of water column.

Open the fuel supply to the regulator and observe the pressure gauge. If the reading is less or greater than 10 inches of water column, remove the cap on the regulator to expose the adjusting screw plug beneath it. Turn the adjusting plug clockwise to increase the fuel supply or counter-clockwise to decrease the fuel supply.

When the supply is properly adjusted to 10 inches of water column, reinstall the protective cap over the adjusting screw on the regulator. Remove the pressure gauge from the fuel line and reinstall the 1/4-inch pipe plug to avoid vibration damage to the gauge.

CHANGING FUEL TYPE

If it is necessary to change the type of fuel from natural gas to LP gas or vice-versa, the fuel line inside the enclosure to the engine must first be switched to the correct regulator on the engine for the desired fuel. After switching the fuel line, set the toggle switch on the engine control to the desired fuel. This tells the engine control module the fuel has been changed so the engine can compensate for the change in fuel supply. After these changes are complete, check the fuel pressure as described in **CONNECTING FUEL SUPPLY LINE TO THE UNIT.**

SUCTION AND DISCHARGE PIPING

Pump performance is adversely effected by increased suction lift, discharge elevation, and friction losses. See the performance curve and notes on Page E-1 to be sure your overall application allows pump to operate within the safe operation range.

Materials

Either pipe or hose maybe used for suction and discharge lines; however, the materials must be compatible with the liquid being pumped. If hose is used in suction lines, it must be the rigid-wall, reinforced type to prevent collapse under suction. Using piping couplings in suction lines is not recommended.

Line Configuration

Keep suction and discharge lines as straight as possible to minimize friction losses. Make minimum use of elbows and fittings, which substantially increase friction loss. If elbows are necessary, use the long-radius type to minimize friction loss.

Connections to Pump

Before tightening a connecting flange, align it exactly with the pump port. Never pull a pipe line into place by tightening the flange bolts and/or couplings.

Lines near the pump must be independently supported to avoid strain on the pump which could cause excessive vibration, decreased bearing life, and increased shaft and seal wear. If hose-type lines are used, they should have adequate support to secure them when filled with liquid and under pressure.

Gauges

Most pumps are drilled and tapped for installing discharge pressure and vacuum suction gauges. If these gauges are desired for pumps that are not tapped, drill and tap the suction and discharge lines not less than 18 inches (457,2 mm) from the suction and discharge ports and install the lines. Installation closer to the pump may result in erratic readings.

SUCTION LINES

To avoid air pockets which could affect pump priming, the suction line must be as short and direct as possible. When operation involves a suction lift, the line must always slope upward to the pump from the source of the liquid being pumped; if the line slopes down to the pump at any point along the suction run, air pockets will be created.

Fittings

Suction lines should be the same size as the pump inlet. If reducers are used in suction lines, they should be the eccentric type, and should be installed with the flat part of the reducers uppermost to avoid creating air pockets. Valves are not normally used in suction lines, but if a valve is used, install it with the stem horizontal to avoid air pockets.

Strainers

If a strainer is furnished with the pump, be certain to use it; any spherical solids which pass through a strainer furnished with the pump will also pass through the pump itself.

If a strainer is not furnished with the pump, but is installed by the pump user, make certain that the total area of the openings in the strainer is at least three or four times the cross section of the suction line, and that the openings will not permit passage of solids larger than the solids handling capability of the pump.

This pump is designed to handle up to 3-inch (76,2 mm) diameter spherical solids.

Sealing

Since even a slight leak will affect priming, head, and capacity, especially when operating with a high suction lift, all connections in the suction line should be sealed with pipe dope to ensure an airtight seal. Follow the sealant manufacturer's rec-

ommendations when selecting and applying the pipe dope. The pipe dope should be compatible with the liquid being pumped.

Suction Lines In Sumps

If a single suction line is installed in a sump, it should be positioned away from the wall of the sump at a distance equal to 1 1/2 times the diameter of the suction line.

If there is a liquid flow from an open pipe into the sump, the flow should be kept away from the suction inlet because the inflow will carry air down into the sump, and air entering the suction line will reduce pump efficiency.

If it is necessary to position inflow close to the suction inlet, install a baffle between the inflow and the suction inlet at a distance 1-1/2 times the diameter of the suction pipe. The baffle will allow entrained air to escape from the liquid before it is drawn into the suction inlet.

If two suction lines are installed in a single sump, the flow paths may interact, reducing the efficiency of one or both pumps. To avoid this, position the suction inlets so that they are separated by a distance equal to at least 3 times the diameter of the suction pipe.

Suction Line Positioning

The depth of submergence of the suction line is critical to efficient pump operation. Figure 2 shows recommended minimum submergence vs. velocity.

NOTE

The pipe submergence required may be reduced by installing a standard pipe increaser fitting at the end of the suction line. The larger opening size will reduce the inlet velocity. Calculate the required submergence using the following formula based on the increased opening size (area or diameter).

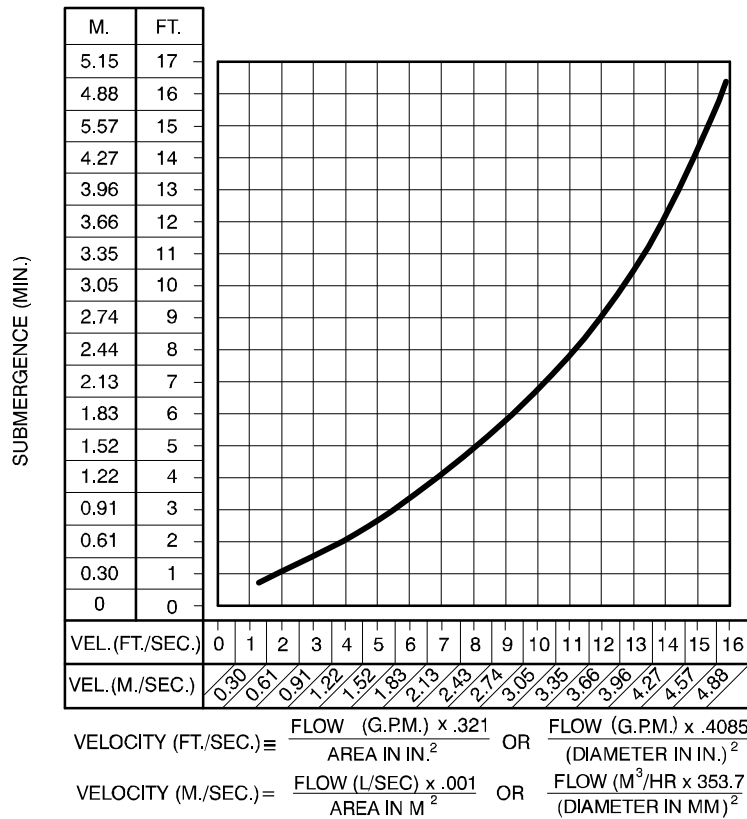

Figure 2. Recommended Minimum Suction Line Submergence vs. Velocity

SUBMERSIBLE TRANSDUCER

This unit is equipped with an optional Electronic Pressure Switch (EPS) that works in conjunction with a submersible transducer. The submersible transducer converts pressure to an electrical signal proportional to liquid level. This electrical signal is distributed to the digital display on the EPS through a scaling circuit which converts the electrical signal to “feet of water”.

When installing the submersible transducer, note the following:

- a. Handle the signal cable and transducer with care during installation. **Carefully** lower the transducer into the wet well or sump; **do not** drop it to the bottom. To avoid clogging, suspend the transducer off the bottom.
- b. **Be sure** to provide sufficient room in the wet well or sump so that the transducer does not get drawn into the suction line. To prevent this, a flexible suction hose may be extended to lay along the bottom of the wet well or sump. The transducer can then be attached to the hose

above the point where it bends along the bottom. See Figure 3 for a typical installation.

- c. The wet well or sump must be vented to atmosphere.
- d. The EPS is scaled in feet of water column. If the measured medium is other than 1.0 specific gravity, the reading on the EPS should be divided by the specific gravity of the measured medium to obtain the actual level.
- e. **Thoroughly** clean the transducer after each use to prevent clogging.



Do not disassemble the transducer or loosen the compression nut at the signal cable entry. **This will void warranty.** There are no user-serviceable parts inside. Do not nick or cut the jacket of the signal cable; this will cause leakage and **void warranty.**

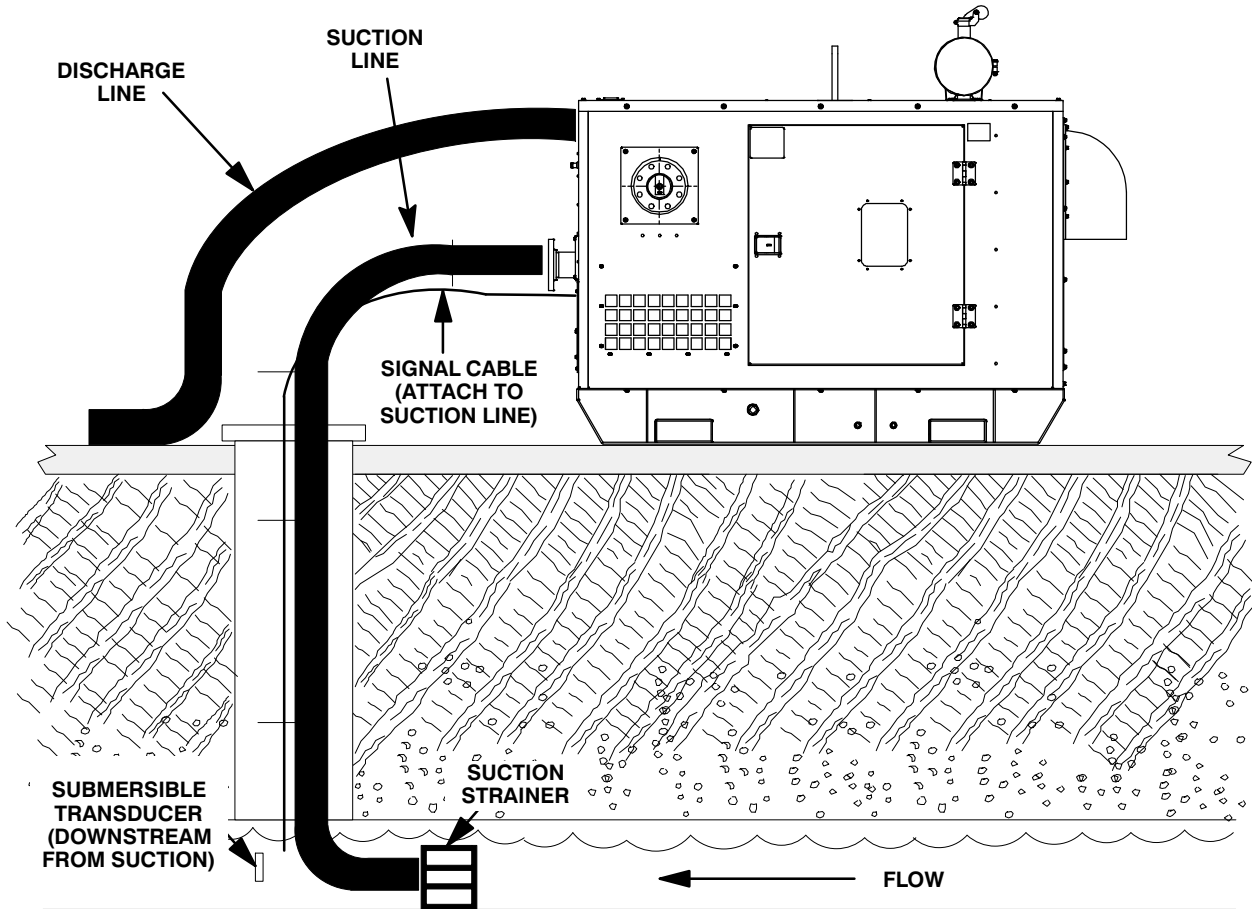

Figure 3. Typical Submersible Transducer Installation

DISCHARGE LINES

Siphoning

Do not terminate the discharge line at a level lower than that of the liquid being pumped unless a siphon breaker is used in the line. Otherwise, a siphoning action causing damage to the pump could result.

Valves

If a throttling valve is desired in the discharge line, use a valve as large as the largest pipe to minimize

friction losses. Never install a throttling valve in a suction line.

With high discharge heads, it is recommended that a throttling valve and a system check valve be installed in the discharge line to protect the pump from excessive shock pressure and reverse rotation when it is stopped.



If the application involves a high discharge head, gradually close the discharge throttling valve before stopping the pump.

OPERATION – SECTION C

OPERATION

Review all SAFETY information in Section A.

Follow the instructions on all tags, labels and decals attached to the pump.



Do not operate an internal combustion engine in an explosive atmosphere. When operating an internal combustion engine in an enclosed area, make sure exhaust fumes are piped to the outside. These fumes contain carbon monoxide, a deadly gas that is colorless, tasteless and odorless.



This pump is designed to handle most non-volatile, non-flammable liquids containing specified entrained solids and corrosives. Do not attempt to pump volatile, corrosive, or flammable liquids which may damage the pump or endanger personnel as a result of pump failure.



Pump speed and operating condition points must be within the continuous performance range shown on the performance curve on page E-1.

STARTING

Check the fuel level and oil levels in the engine, air compressor, pump bearings and seal housing.

Make sure the pump is level. Lower the jack stands and chock the wheels, if so equipped.



Make sure the pump is level. Lower jack stands and chock the wheels, if so equipped. Use caution when positioning the skid-mounted unit to prevent damage to the fuel tank.



This pump is equipped with an automatic starting system, and is subject to automatic restart. Keep hands and clothing away from the unit to prevent injury during automatic operation. Disconnect the positive battery cable before performing any maintenance. Failure to do so may result in serious personal injury.

Consult the engine operations manual before attempting to start the unit.

Consult the manual accompanying the engine control box and start the pump.

PRIMING

Install the pump and piping as described in **INSTALLATION**. Make sure that the piping connections are tight, and that the pump is securely mounted. Check that the pump is properly lubricated (see **LUBRICATION** in **MAINTENANCE AND REPAIR**).

This pump is self-priming, but the pump should never be operated unless there is liquid in the pump casing.



Never operate this pump unless there is liquid in the pump casing. The pump will not prime when dry. Extended operation of a dry pump will destroy the seal assembly.

Add liquid to the pump casing when:

1. The pump is being put into service for the first time.
2. The pump has not been used for a considerable length of time.
3. The liquid in the pump casing has evaporated.

Once the pump casing has been filled, the pump will prime and reprime as necessary.



After filling the pump casing, reinstall and tighten the fill plug. Do not attempt to operate the pump unless all connecting piping is securely installed. Otherwise, liquid in the pump forced out under pressure could cause injury to personnel.

To fill the pump, remove the pump casing fill cover or fill plug in the top of the casing, and add clean liquid until the casing is filled. Replace the fill cover or fill plug before operating the pump.

NOTE

If the suction or discharge piping is open, a hose can be used to fill the casing through the piping.

OPTIONAL EPS CONTROL

Features

The optional EPS Control is equipped with a 12VDC Electronic Pressure Switch which includes the following features:

- 3 Output Relays:
 1. A output, delayed
 2. B output, no delay
 3. Horn output, no delay
- 3 Inputs:
 1. Horn silence
 2. Pressure transducer
 3. Low Temp Thermostat
- LCD screen with backlight for function monitoring
- Bright LEDs to indicate output status and display modes

- Three switches on front panel for **all** adjustments
- Battery level indicator on LCD screen to alert operator of low battery condition
- Microprocessor Control
- Error display to alert user of errors in calibration

Functional Description

Front Panel Controls/Displays

1. The LCD screen displays level information, A and B setpoint off/on levels, Horn delay, and calibration information.

Typical Messages on the display:

- a) EEP bAd... Eeprom memory is not correct, user **must** recalibrate unit.
- b) USr CAL... User calibrate mode, i.e., user **wants** to calibrate unit.
- c) SEt a.oF... A OFF setpoint, units of level.
- d) SEt a.on... A ON setpoint, units of level.
- e) SEt b.oF... B OFF setpoint, units of level.
- f) SEt b.on... B ON setpoint, units of level.
- g) Hrn dLy... Horn on, A output delay time, 5–30 seconds, in 5-second increments.
- h) LO BAT... Indicator, shows battery voltage level is below 12VDC.
- i) Lo tpt... Shows status of Low Temperature Thermostat contacts.

2. LEDs:



- a) When the green LED is lighted, the unit is showing level on the LCD display.
- b) When the A output LED is lighted, the A output relay is closed.
- c) When the B output LED is lighted, the B output relay is closed

NOTE

LED's and all segments of the display are lighted

upon connection of power as a lamp test feature. However, no relay outputs are closed during test.

3. Switches:

- a) The  switch functions as a “round robin” type switch. Pressing this switch will cause the unit to show the next selection in the order listed above.
- b) The  switch functions to decrease the selection showing. This switch can be used to decrease the smallest digit by “bumping” the switch, or to continuously decrease the digit by pressing and holding for at least one second and releasing when desired setting is reached.
- c) The  switch functions to increase the selection showing. This switch can be used to increase the smallest digit by “bumping” the switch, or to continuously increase the digit by pressing and holding for at least one second and releasing when desired setting is reached.

Liquid level adjustment of the Electronic Pressure Switch is accomplished using the three buttons on the control. For EPS functions and level adjustment, refer to the following instructions.

EPS Functions

Actual functions of the control occur as follows:

Power is applied to the unit.

Unit performs display test for approximately 4 seconds.

When the pressure level showing is equal to or greater than the “A.on” setpoint, the Horn output contacts will close in approximately 1 second and a delay, equal to the “Hrn dLy” time, will occur before the A output contacts close.

When the level showing is equal to or greater than the “B.on” setpoint, the B output contacts will close in approximately 1 second.

When the pressure decreases to a level equal to or less than the “B.of” setpoint, B output contacts will open in approximately one second.

When the pressure decreases to a level equal to or less than the “A.of” setpoint, A output contacts will open in approximately one second.

If an optional Low Temperature Thermostat is connected to the unit and the thermostat contacts close, the unit displays “lo tpt” on the display. In approximately 1 second, the Horn output contacts close, then after the “Hrn dLy” time, A output contacts close. A output contacts will remain closed as long as Low Temperature Thermostat contacts are closed.

When the Low Temperature Contacts open, A output contact will open **only** if the level is equal to or less than the “A.off” setpoint.

As long as the Low Temperature Thermostat contacts are closed, the display will show “lo tpt” unless  switch is pressed to display some other information. Level is not viewable until the Low Temperature Thermostat contacts open.

The user may wish to check Setpoints Off/On and Horn output/A output delay times. “Bumping” the  switch will display all of the information desired.

NOTE

One second delays in contact opening/closing is a result of time sampling of the pressure signal to filter false signals that could cause “nuisance” tripping of the contacts.

NOTE

If the “Hrn dLy” is changed during the actual A output delay cycle, the current cycle is not changed; the change becomes effective on the next A output delay cycle.



Use caution to ensure that the “--.on” setpoint (i.e. “A.on”) is not adjusted to a level less than the corresponding “--.of” setpoint (i.e. “A.of”). Improper adjustment of the off/on setpoints will render the unit non-functional, resulting in flooding.

EPS Calibration



NOTE

Zero offset and span adjustments are only necessary to calibrate a new unit, or when replacing the transducer. Once calibrated, "ON" and "OFF" setpoints will be stored in the unit's memory. Liquid level adjustments will be used whenever "ON" and "OFF" liquid levels must be reset.

There are two reasons for the user to calibrate the unit. When power is applied, the unit confirms setpoints and other calibration information for validity. If the setpoints are not valid, the LCD screen shows "EEP bAd" and the unit must be recalibrated. Also, if the unit is moved, or some other external change takes place, the unit must be recalibrated.

Zero Adjustment



Zero adjustment tells the unit when the transducer is exposed to zero water (atmospheric) pressure. When recalibration is desired, hold the transducer in hand and apply power to the unit. The LCD screen will display "Level ABC". Press and hold  for 5 seconds. The LCD screen displays "Input? External XDUCR". Perform the following calibration procedures.

Press  3 times and the LCD screen will display "Calibrate Zro". Press  or  until a character or number on the display changes.

Press  to accept the entry and advance to "Calibrate Span".







Span Adjustment

Span adjustment calibrates the unit to a known water pressure (depth). To set:

Submerge the transducer to an exact known depth. At "Calibrate Span", the span setting in the unit's memory will display. Press  to increase or  to decrease the value until the LCD screen display equals the actual known depth of the transducer.

Level Adjustment

Level adjustment tells the unit when to turn the pump on and off. To set:

From "Level ABC" display, press  once and "Pump Setpt A On" will display. Press  to increase or  to decrease to the desired level at which the pump turns on. Press  to advance to "Pump Setpt A Off". Press  to increase or  to decrease to the desired level at which the pump turns off.

Press  again to advance to "Pump Setpt B On". If "B" is to be used, repeat the procedure described above for adjusting level "A".

Horn Delay

The horn delay is pre-set from the factory through the engine control panel, therefore this function is not utilized through the EPS.

ROUTINE OPERATION

Adjust the engine speed to achieve the desired output. Do not exceed the factory set engine speed and system operating pressure. Do not operate below the recommended operating speed (if applicable).



Never tamper with the governor to gain more power. The governor establishes safe operating limits that should not be exceeded. Refer to the Performance Curve in Section E for the maximum continuous operating speed for this pump.

A Gorman-Rupp automatic air release valve may be installed in a bypass line, or the bypass line may be left open.



A manual shut-off valve should not be installed in any bypass line. A manual shut-off valve may inadvertently be left closed during operation. A pump which has lost prime may continue to operate without reaching prime, causing dangerous overheating and possible explosive rupture of the pump casing. Personnel could be severely injured.

Lines With a Bypass

If a Gorman-Rupp Automatic Air Release Valve has been installed, the valve will automatically open to allow the pump to prime, and automatically close after priming is complete (see **INSTALLATION** for Air Release Valve operation).

If the bypass line is open, air from the suction line will be discharged through the bypass line back to the wet well during the priming cycle. Liquid will then continue to circulate through the bypass line while the pump is in operation.

Lines Without a Bypass

Open all valves in the discharge line and start the engine. Priming is indicated by a positive reading on the discharge pressure gauge or by a quieter operation. The pump may not prime immediately because the suction line must first fill with liquid. If the pump fails to prime within five minutes, stop it and check the suction line for leaks.

After the pump has been primed, partially close the discharge line throttling valve in order to fill the line slowly and guard against excessive shock pressure which could damage pipe ends, gaskets, sprinkler heads, and any other fixtures connected to the line. When the discharge line is completely filled, adjust the throttling valve to the required flow rate.

OPERATION IN EXTREME HEAT

The safety shutdown system will automatically stop the unit if engine operating temperature exceeds design limits. If engine over-temperature shutdown occurs, allow the unit to cool before re-starting.

If engine overheating continues, check the engine lubricant level and viscosity. Consult the engine operation manual for the recommended lubricant for operation in extreme heat.

If the unit is being operated in the **automatic** mode, adjust the liquid level device(s) to allow shorter run and longer cooling periods, if possible.

OPERATIONAL CHECKS

Leakage

Once the pump is fully primed, no leakage should be visible at pump mating surfaces, or at pump connections or fittings. Keep all line connections and fittings tight to maintain maximum pump efficiency.

Pump Vacuum Check

Read the vacuum gauge with the pump primed and at operation speed. Shut off the pump. The vacuum gauge reading will immediately drop proportionate to static suction lift, and should then stabilize. If the vacuum reading falls off rapidly after stabilization, an air leak exists. Before checking for the source of the leak, check the point of installation of the vacuum gauge.

Liquid Temperature And Overheating

The **maximum** liquid temperature for this pump is 160°F (71°C). Do not apply it at a higher operating temperature.

Overheating can occur if operated with the valves in the suction or discharge lines closed. Operating against closed valves could bring the liquid to a boil, build pressure, and cause the pump to rupture or explode. If overheating occurs, stop the pump immediately and allow it to completely cool before servicing it. **Approach any over-heated pump cautiously.**



Allow an over-heated pump to completely cool before servicing. Do not remove plates, covers, gauges, or fittings from an overheated pump. Liquid within the pump can reach boiling temperatures, and vapor pressure within the pump can cause parts being disengaged to be ejected with great force. After the pump cools, drain the liquid from the pump by removing the casing drain plug. Use caution when removing the plug to prevent injury to personnel from hot liquid.

Strainer Check

Check the strainer regularly, and clean it as necessary. The strainer should also be checked if pump flow rate begins to drop. Monitor and record the vacuum suction gauge readings regularly to detect strainer blockage.

Never introduce air or steam pressure into the pump casing or piping to remove a blockage. This could result in personal injury or damage to the equipment. If backflushing is absolutely necessary, **liquid pressure** must be limited to 50% of the maximum permissible operating pressure shown on the pump performance curve.

STOPPING

Manual Stopping

In the manual mode, reduce the throttle speed slowly, and allow the engine to idle briefly before turning the keyswitch to 'OFF'.



If the application involves a high discharge head, gradually close the discharge throttling valve before stopping the pump.

Automatic Stopping

In the automatic mode, the pump will stop when the liquid in the wet well or sump lowers and activates the "Off" liquid level device(s). The pump will restart automatically when the liquid rises and activates the "On" liquid level device(s).

Safety Shutdown System

The unit is equipped with a safety system to automatically shut down the engine under certain conditions.

Displays on the control panel will indicate which of the safety features has caused the engine to shut down.

Should any of the safety features cause the engine to shut down, **the cause must be determined and corrected** before putting the unit back into service.

All safety shutdown features are pre-set at the factory for optimum performance and safety; **do not** attempt to adjust these settings.



Never disconnect any of the safety shutdown features; this will void the warranty and could result in serious damage to the unit and/or injury to personnel. Safety shutdown features are pre-set at the factory; do not attempt to adjust any of the settings. Determine the cause of shutdown before putting the unit back into service. Consult the factory for additional information.

PERIODIC CHECKS

Seal Cavity and Bearing Lubrication

Both the seal and bearing cavities were fully lubricated at the factory. Check the lubrication levels before startup, and regularly thereafter as indicated in Section E, **Maintenance and Repair**. When lubrication is required, use **only** SAE No. 30 non-detergent oil.

Bearing Temperature Check

Bearings normally run at higher than ambient temperatures because of heat generated by friction. Temperatures up to 160°F (71°C) are considered normal for bearings, and they can operate safely to at least 180°F (82°C).

Checking bearing temperatures by hand is inaccurate. Bearing temperatures can be measured accurately by placing a contact-type thermometer against the housing. Record this temperature for future reference.

A sudden increase in bearing temperatures is a warning that the bearings are at the point of failing to operate properly. Make certain that the bearing lubricant is of the proper viscosity and at the correct level (see **LUBRICATION** in Section E, **Maintenance and Repair**). Bearing overheating can also be caused by shaft misalignment and/or excessive vibration.

When pumps are first started, the bearings may seem to run at temperatures above normal. Continued operation should bring the temperatures down to normal levels.

Engine Fuel Filter

Consult the manual accompanying the engine, and change the fuel filter periodically as indicated. If operated under extremely dusty and/or humid

conditions, change the filter more frequently. Irregular performance and loss of power usually indicate a dirty fuel filter.

Engine Oil

The engine was lubricated for test at the factory. However, **always** check the lubrication level before startup.

Consult the manual accompanying the engine, and change the oil filter periodically as indicated. If operated under extremely dusty conditions, change the filter more frequently.

COLD WEATHER PRESERVATION

In below freezing conditions, drain the pump to prevent damage from freezing. Also, clean out any solids by flushing with a hose. Operate the pump for approximately one minute; this will remove any remaining liquid that could freeze the pump rotating parts. If the pump will be idle for more than a few hours, or if it has been pumping liquids containing a large amount of solids, drain the pump, and flush it thoroughly with clean water. To prevent large solids from clogging the drain port and preventing the pump from completely draining, insert a rod or stiff wire in the drain port, and agitate the liquid during the draining process. Clean out any remaining solids by flushing with a hose.

TROUBLESHOOTING – SECTION D

Review all SAFETY information in Section A.



Before attempting to open or service the pump:

1. Familiarize yourself with this manual.
2. Shut down the engine, remove the key and disconnect the positive battery cable to ensure that the pump will remain inoperative.
3. Allow the pump to completely cool if overheated.
4. Check the temperature before opening any covers, plates, or plugs.

5. Close the suction and discharge valves.
6. Vent the pump slowly and cautiously.
7. Drain the pump.



This pump is equipped with an automatic starting system, and is subject to automatic restart. Keep hands and clothing away from the unit to prevent injury during automatic operation. Disconnect the positive battery cable before performing any maintenance. Failure to do so may result in serious personal injury.

TROUBLE	POSSIBLE CAUSE	PROBABLE REMEDY
PUMP FAILS TO PRIME	Not enough liquid in casing. Suction check valve contaminated or damaged. Air leak in suction line. Lining of suction hose collapsed. Leaking or worn seal or pump gasket. Suction lift or discharge head too high. Strainer clogged.	Add liquid to casing. See PRIMING . Clean or replace check valve. Correct leak. Replace suction hose. Check pump vacuum. Replace leaking or worn seal or gasket. Check piping installation and install bypass line if needed. See INSTALLATION . Check strainer and clean if necessary.
PUMP STOPS OR FAILS TO DELIVER RATED FLOW OR PRESSURE	Air leak in suction line. Lining of suction hose collapsed. Leaking or worn seal or pump gasket. Strainer clogged. Suction intake not submerged at proper level or sump too small.	Correct leak. Replace suction hose. Check pump vacuum. Replace leaking or worn seal or gasket. Check strainer and clean if necessary. Check installation and correct submergence as needed.

TROUBLE	POSSIBLE CAUSE	PROBABLE REMEDY
PUMP STOPS OR FAILS TO DELIVER RATED FLOW OR PRESSURE (cont.)	<p>Impeller or other wearing parts worn or damaged.</p> <p>Impeller clogged.</p> <p>Discharge head too high.</p> <p>Suction lift too high.</p> <p>Pump speed too slow.</p> <p>EPS limit switches set improperly or submersible transducer clogged.</p>	<p>Replace worn or damaged parts. Check that impeller is properly centered and rotates freely.</p> <p>Free impeller of debris.</p> <p>Install bypass line.</p> <p>Measure lift w/vacuum gauge. Reduce lift and/or friction losses in suction line.</p> <p>Check engine output; consult engine operation manual.</p> <p>Check EPS limit settings; check and clean submersible transducer.</p>
PUMP REQUIRES TOO MUCH POWER	<p>Pump speed too high.</p> <p>Discharge head too low.</p> <p>Liquid solution too thick.</p> <p>Bearing(s) frozen.</p>	<p>Check engine output.</p> <p>Adjust discharge valve.</p> <p>Dilute if possible.</p> <p>Disassemble pump and check bearing(s).</p>
PUMP CLOGS FREQUENTLY	<p>Discharge flow too slow.</p> <p>Suction check valve or foot valve clogged or binding.</p> <p>Liquid solution too thick.</p>	<p>Open discharge valve fully to increase flow rate, and run engine at maximum governed speed.</p> <p>Clean valve.</p> <p>Dilute if possible.</p>
EXCESSIVE NOISE	<p>Cavitation in pump.</p> <p>Pumping entrained air.</p> <p>Pump or drive not securely mounted.</p> <p>Impeller clogged or damaged.</p>	<p>Reduce suction lift and/or friction losses in suction line. Record vacuum and pressure gauge readings and consult local representative or factory.</p> <p>Locate and eliminate source of air bubble.</p> <p>Secure mounting hardware.</p> <p>Clean out debris; replace damaged parts.</p>
BEARINGS RUN TOO HOT	<p>Bearing temperature is high, but within limits.</p> <p>Low or incorrect lubricant.</p> <p>Suction and discharge lines not properly supported.</p> <p>Drive misaligned.</p>	<p>Check bearing temperature regularly to monitor any increase.</p> <p>Check for proper type and level of lubricant.</p> <p>Check piping installation for proper support.</p> <p>Align drive properly.</p>

PREVENTIVE MAINTENANCE

Since pump applications are seldom identical, and pump wear is directly affected by such things as the abrasive qualities, pressure and temperature of the liquid being pumped, this section is intended only to provide general recommendations and practices for preventive maintenance. Regardless of the application however, following a routine preventive maintenance schedule will help assure trouble-free performance and long life from your Gorman-Rupp pump. For specific questions concerning your application, contact your Gorman-Rupp distributor or the Gorman-Rupp Company.

Record keeping is an essential component of a good preventive maintenance program. Changes in suction and discharge gauge readings (if so

equipped) between regularly scheduled inspections can indicate problems that can be corrected before system damage or catastrophic failure occurs. The appearance of wearing parts should also be documented at each inspection for comparison as well. Also, if records indicate that a certain part (such as the seal) fails at approximately the same duty cycle, the part can be checked and replaced before failure occurs, reducing unscheduled down time.

For new applications, a first inspection of wearing parts at 250 hours will give insight into the wear rate for your particular application. Subsequent inspections should be performed at the intervals shown on the chart below. Critical applications should be inspected more frequently.

Preventive Maintenance Schedule					
Item	Service Interval*				
	Daily	Weekly	Monthly	Semi-Annually	Annually
General Condition (Temperature, Unusual Noises or Vibrations, Cracks, Leaks, Loose Hardware, Etc.)	I				
Pump Performance (Gauges, Speed, Flow)	I				
Bearing Lubrication		I			R
Seal Lubrication (And Packing Adjustment, If So Equipped)		I			R
V-Belts (If So Equipped)			I		
Air Release Valve Plunger Rod (If So Equipped)			I	C	
Front Impeller Clearance (Wear Plate)				I	
Rear Impeller Clearance (Seal Plate)				I	
Check Valve					I
Pressure Relief Valve (If So Equipped)					C
Pump and Driver Alignment					I
Shaft Deflection					I
Bearings					I
Bearing Housing					I
Piping					I
Driver Lubrication – See Mfgr’s Literature					I

Legend:
 I = Inspect, Clean, Adjust, Repair or Replace as Necessary
 C = Clean
 R = Replace

* Service interval based on an intermittent duty cycle equal to approximately 4000 hours annually. Adjust schedule as required for lower or higher duty cycles or extreme operating conditions.

PUMP MAINTENANCE AND REPAIR - SECTION E

MAINTENANCE AND REPAIR OF THE WEARING PARTS OF THE PUMP WILL MAINTAIN PEAK OPERATING PERFORMANCE.

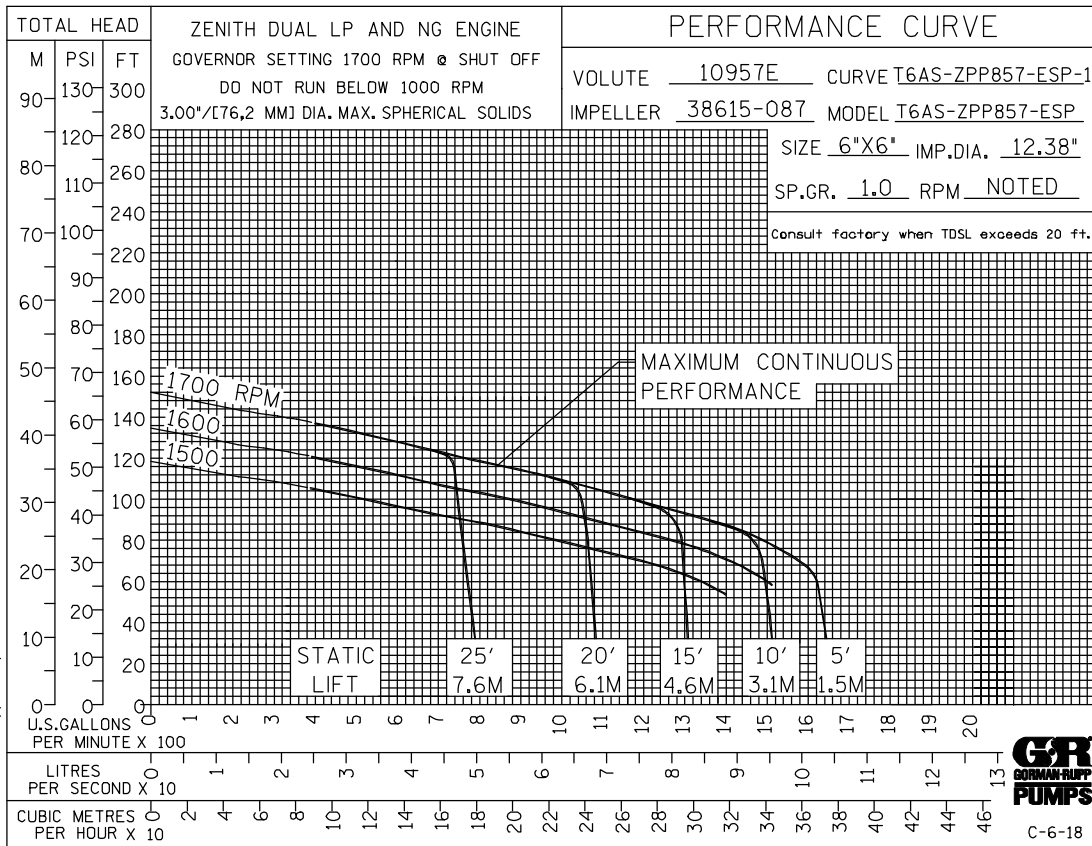

*** STANDARD PERFORMANCE FOR PUMP MODEL T6A60S-ZPP857-ESP**

* Based on 70°F (21°C) clear water at sea level with minimum suction lift. Since pump installations are seldom identical, your performance may be different due to such factors as viscosity, specific gravity, elevation, temperature, and impeller trim.

Contact the Gorman-Rupp Company to verify performance or part numbers.



Pump speed and operating condition points must be within the continuous performance range shown on the curve.

If your pump serial number is followed by an "N", your pump is **NOT** a standard production model.

ILLUSTRATION

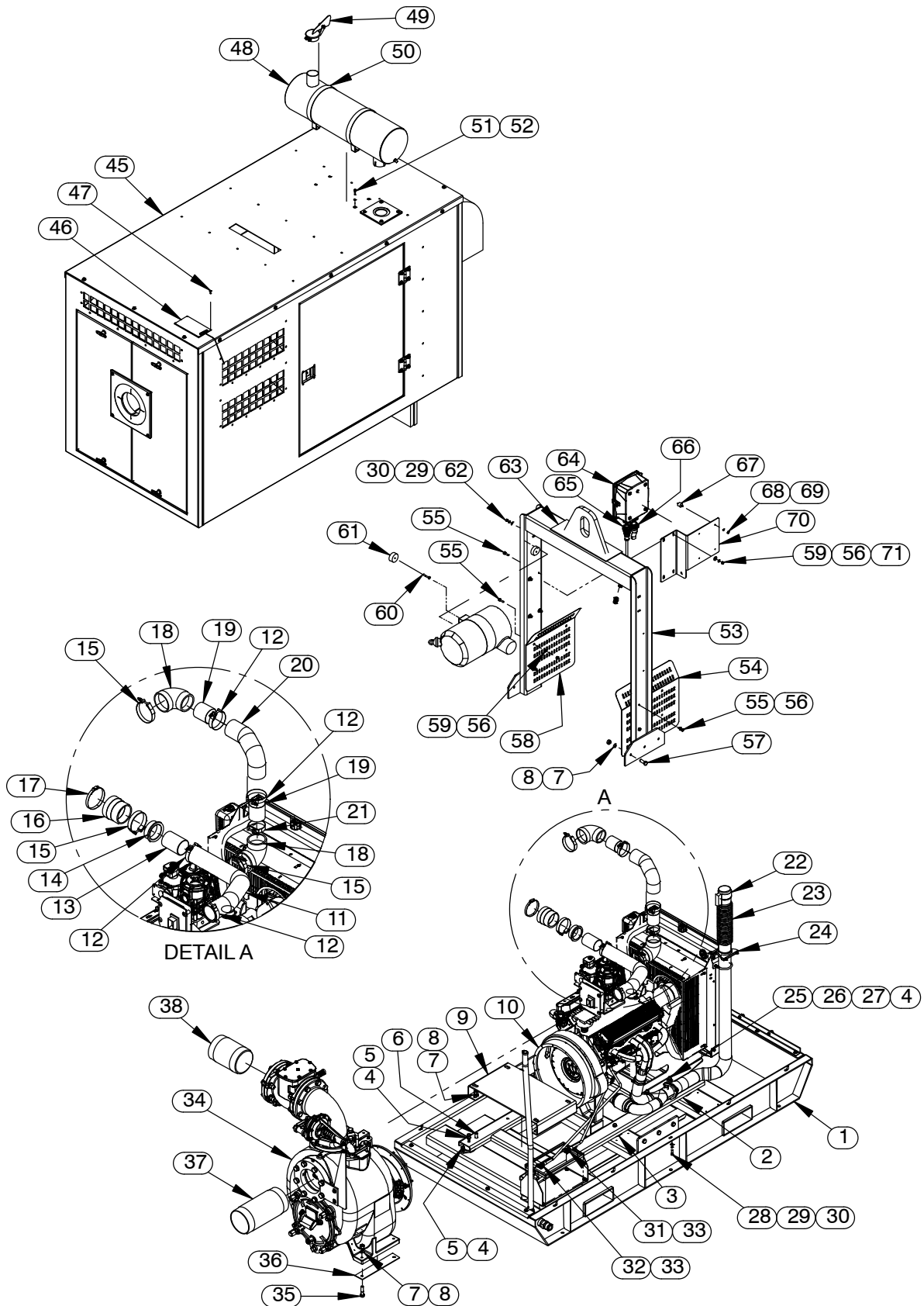

Figure 1. Pump Model T6A60S-ZPP857-ESP

PARTS LIST
Pump Model T6A60S-ZPP857-ESP
 (From S/N 1703506 Up)

If your pump serial number is followed by an "N", your pump is **NOT** a standard production model. Contact the Gorman-Rupp Company to verify part numbers.

ITEM NO.	PART NAME	PART NUMBER	QTY	ITEM NO.	PART NAME	PART NUMBER	QTY
1	BASE WELDMENT	41565-603 24150	1	58	HEAT SHIELD	34167-015 15120	1
2	SUB BASE ASSY	41531-576 24150	1	59	HEX NUT	D06 15991	6
3	COMPRESSION MOUNT	24631-104	6	60	HEX HEAD CAP SCREW	B0508 15991	2
4	LOCK WASHER	J08 15991	24	61	SPACER	31141-037 13000	2
5	HEX HEAD CAP SCREW	B0805 15991	18	62	HEX NUT	D05 15991	2
6	HEX HEAD CAP SCREW	B1006 15991	4	63	GASKET	33311-060 19460	1
7	LOCK WASHER	J10 15991	14	64	CONTROL PANEL	29196-071	1
8	HEX NUT	D10 15991	14	65	TRNSDCR HARNESS	29196-076	1
9	PUMP MNTG BRCKT ASSY	41581-094 24150	1	66	INTERFACE HARNESS	29196-075	1
10	ZENITH ZPP857 ENGINE	29267-008	1	67	STUD MOUNT	24631-014	4
11	THERMO HOSE X 36" LG	18533-173	1	68	HEX NUT	D04 15991	4
12	TBOLT CLAMP 3.5 IN	26518-164	4	69	LOCK WASHER	J04 15991	4
13	EXHAUST TUBING	31417-076 15210	1	70	MOUNTING BRACKET	34512-065 13000	1
14	AIR INTAKE REDCG INSRT	29284-043	1	71	FLAT WASHER	K06 15991	4
15	T-BOLT CLAMP 4 IN	26518-165	3	72	MOUNTING ASS'Y	41881-788	1
16	SLEEVE	26413-002	1	73	THREADED INSERT	21769-160	8
17	HOSE CLAMP	26518-678	1	74	HEX HEAD CAP SCREW	B0504 15991	11
18	ELBOW, REDUCING, 90°	29284-040	2	75	BATTERY BOX ASSY	42432-005	1
19	AIR INTAKE PIPE	31417-066 15210	2	76	OPW ADAPTER 1 1/4	26531-404	1
20	THERMO HOSE X 18" LG	18533-173	1	77	REDUCER PIPE BUSHING	AP2016 11999	2
21	T-BOLT CLAMP 3 IN	26518-163	2	78	STREET ELBOW	RS16 11999	1
22	EXHAUST CLAMP	29334-287	1	79	HOSE FITTING	26523-394	3
23	FLEX CONNECTOR	31782-004	1	80	HOSE CLAMP	26518-666	4
24	MUFFLER CLAMP 3.50	S2227	1	81	HOSE 1" ID X 26" LG	18513-045	1
25	HEX HEAD CAP SCREW	B0806 15991	6	82	SUCTION TRANSDUCER	27780-988	1
26	HEX NUT	D08 15991	6	83	PIPE ELBOW	R16 15079	1
27	FLAT WASHER	K08 15991	6	84	PIPE NIPPLE	T1608 15079	1
28	HEX HEAD CAP SCREW	B0505 15991	10	85	REDUCER PIPE BUSHING	AP2016 17040	1
29	LOCK WASHER	J05 15991	23	86	CLOSE PIPE NIPPLE	T16 15079	1
30	FLAT WASHER	K05 15991	23	87	BALL VALVE	26631-025	1
31	1/0 POS. CABLE ASSY	47311-112	1	88	HOSE 1" ID X 58" LG	18513-045	1
32	1/0 NEG. CABLE ASSY	47311-142	1	89	PIPE PLUG	P20 10009	1
33	SQUARE HEAD BOLT	A0506 15991	2	90	PIPE PLUG	P32 14990	3
34	PUMP END ASSEMBLY	46186-187	1	91	DSCHRG TRANSDUCER	27780-989	1
35	HEX HEAD CAP SCREW	B1010 15991	4	92	HOSE CLAMP	26518-641	2
36	PUMP SPACER	33246-058 15120	2	93	HOSE .38 I.D. X 28" LG	18513-054	1
37	PIPE NIPPLE	T9654 15079	1	94	MALE HOSE END	26525-020	2
38	PIPE NIPPLE	T9636 15079	1	95	PIPE PLUG	P08 15079	2
39	CLOSE PIPE NIPPLE	T16 15070	3	96	HOSE .38 I.D. X 24" LG	18513-054	1
40	PIPE ELBOW	R16 15070	1	NOT SHOWN:			
41	PIPE TEE	U16 11990	1		ENG OPERATION DECAL	38816-347	1
42	REDUCER PIPE BUSHING	AP1604 15070	1		ENGINE START-UP TAG	38816-269	1
43	PIPE PLUG	P04 15070	1		CAUTION DECAL	38816-169	1
44	NAT GAS & LPG HOSE	29332-306	1		WARNING DECAL	2613FE	1
45	ENCLOSURE ASSY	42164-051	1		PUMP DRAIN LABEL	38816-320	1
46	SOLAR CHARGER	27558-013	1		WARNING DECAL	38817-101	2
47	TAP SCREW #10 X 3/4	21281-446	6		AIR RLSE DRAIN LABEL	38816-333	1
48	MUFFLER 3"	29334-105	1		WARNING DECAL	38816-203	4
49	WEATHER CAP	S2021	1		FOAM TAPE 279" LG	18668-003	1
50	10" DIA MOUNTING BRKT	29334-288	2		RADIATOR DRAIN LABEL	38816-322	1
51	HEX HEAD CAP SCREW	B0505 15991	4		OIL DRAIN LABEL	38816-323	1
52	LOCK WASHER	J05 15991	4		WARNING DECAL	38816-345	2
53	HOIST BAIL ASSY	44713-067 24150	1		INSTRUCTION DECAL	38818-144	1
54	HEAT SHIELD ASSY	42381-145	1		EXHAUST BLANKET	46241-018	1
55	HEX HEAD CAP SCREW	B0605 15991	20		EXHST INSULTN WRAP	29330-441	2
56	LOCK WASHER	J06 15991	20		9" SNAP STRAP	29330-443	8
57	HEX HEAD CAP SCREW	B1006-1/2 15991	6		18" SNAP STRAP	29330-444	4

ILLUSTRATION

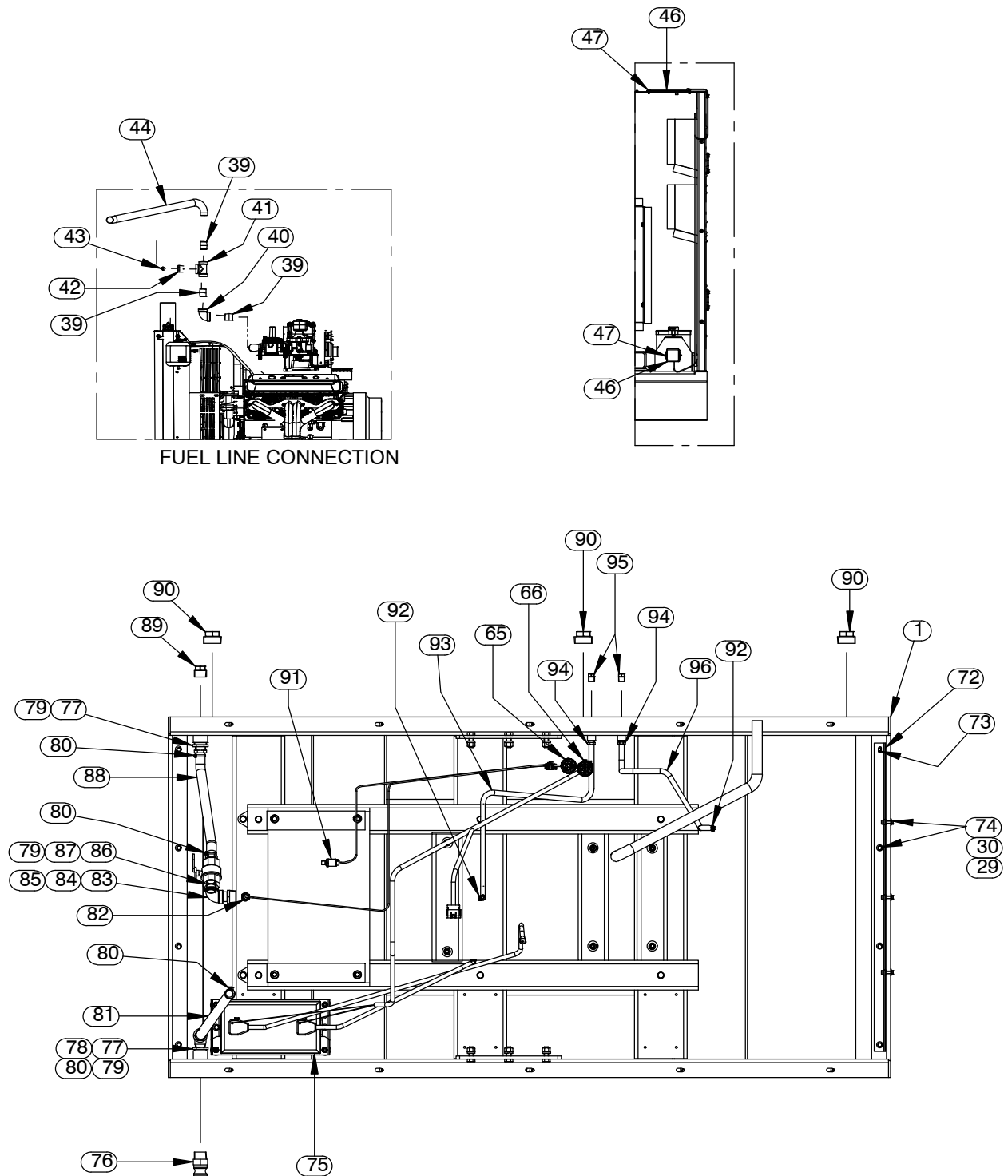

Figure 2. Pump Model T6A60S-ZPP857-ESP (cont'd)

PARTS LIST
Pump Model T6A60S-ZPP857-ESP

ITEM NO.	PART NAME	PART NUMBER	QTY	ITEM NO.	PART NAME	PART NUMBER	QTY
1	BASE WELDMENT	41565-603 24150	1	58	HEAT SHIELD	34167-015 15120	1
2	SUB BASE ASSY	41531-576 24150	1	59	HEX NUT	D06 15991	6
3	COMPRESSION MOUNT	24631-104	6	60	HEX HEAD CAP SCREW	B0508 15991	2
4	LOCK WASHER	J08 15991	24	61	SPACER	31141-037 13000	2
5	HEX HEAD CAP SCREW	B0805 15991	18	62	HEX NUT	D05 15991	2
6	HEX HEAD CAP SCREW	B1006 15991	4	63	GASKET	33311-060 19460	1
7	LOCK WASHER	J10 15991	14	64	CONTROL PANEL	29196-071	1
8	HEX NUT	D10 15991	14	65	TRNSDCR HARNESS	29196-076	1
9	PUMP MNTG BRCKT ASSY	41581-094 24150	1	66	INTERFACE HARNESS	29196-075	1
10	ZENITH ZPP857 ENGINE	29267-008	1	67	STUD MOUNT	24631-014	4
11	THERMO HOSE X 36" LG	18533-173	1	68	HEX NUT	D04 15991	4
12	TBOLT CLAMP 3.5 IN	26518-164	4	69	LOCK WASHER	J04 15991	4
13	EXHAUST TUBING	31417-076 15210	1	70	MOUNTING BRACKET	34512-065 13000	1
14	AIR INTAKE REDCG INSRT	29284-043	1	71	FLAT WASHER	K06 15991	4
15	T-BOLT CLAMP 4 IN	26518-165	3	72	MOUNTING ASS'Y	41881-788	1
16	SLEEVE	26413-002	1	73	THREADED INSERT	21769-160	8
17	HOSE CLAMP	26518-678	1	74	HEX HEAD CAP SCREW	B0504 15991	11
18	ELBOW, REDUCING, 90°	29284-040	2	75	BATTERY BOX ASSY	42432-005	1
19	AIR INTAKE PIPE	31417-066 15210	2	76	OPW ADAPTER 1 1/4	26531-404	1
20	THERMO HOSE X 18" LG	18533-173	1	77	REDUCER PIPE BUSHING	AP2016 11999	2
21	T-BOLT CLAMP 3 IN	26518-163	2	78	STREET ELBOW	RS16 11999	1
22	EXHAUST CLAMP	29334-287	1	79	HOSE FITTING	26523-394	3
23	FLEX CONNECTOR	31782-004	1	80	HOSE CLAMP	26518-666	4
24	MUFFLER CLAMP 3.50	S2227	1	81	HOSE 1" ID X 26" LG	18513-045	1
25	HEX HEAD CAP SCREW	B0806 15991	6	82	SUCTION TRANSDUCER	27780-988	1
26	HEX NUT	D08 15991	6	83	PIPE ELBOW	R16 15079	1
27	FLAT WASHER	K08 15991	6	84	PIPE NIPPLE	T1608 15079	1
28	HEX HEAD CAP SCREW	B0505 15991	10	85	REDUCER PIPE BUSHING	AP2016 17040	1
29	LOCK WASHER	J05 15991	23	86	CLOSE PIPE NIPPLE	T16 15079	1
30	FLAT WASHER	K05 15991	23	87	BALL VALVE	26631-025	1
31	1/0 POS. CABLE ASSY	47311-112	1	88	HOSE 1" ID X 58" LG	18513-045	1
32	1/0 NEG. CABLE ASSY	47311-142	1	89	PIPE PLUG	P20 10009	1
33	SQUARE HEAD BOLT	A0506 15991	2	90	PIPE PLUG	P32 14990	3
34	PUMP END ASSEMBLY	46186-187	1	91	DSCHRG TRANSDUCER	27780-989	1
35	HEX HEAD CAP SCREW	B1010 15991	4	92	HOSE CLAMP	26518-641	2
36	PUMP SPACER	33246-058 15120	2	93	HOSE .38 I.D. X 28" LG	18513-054	1
37	PIPE NIPPLE	T9654 15079	1	94	MALE HOSE END	26525-020	2
38	PIPE NIPPLE	T9636 15079	1	95	PIPE PLUG	P08 15079	2
39	CLOSE PIPE NIPPLE	T16 15070	3	96	HOSE .38 I.D. X 24" LG	18513-054	1
40	PIPE ELBOW	R16 15070	1		NOT SHOWN:		
41	PIPE TEE	U16 11990	1		ENG OPERATION DECAL	38816-347	1
42	REDUCER PIPE BUSHING	AP1604 15070	1		ENGINE START-UP TAG	38816-269	1
43	PIPE PLUG	P04 15070	1		CAUTION DECAL	38816-169	1
44	NAT GAS & LPG HOSE	29332-306	1		WARNING DECAL	2613FE	1
45	ENCLOSURE ASSY	42164-051	1		PUMP DRAIN LABEL	38816-320	1
46	SOLAR CHARGER	27558-013	1		WARNING DECAL	38817-101	2
47	TAP SCREW #10 X 3/4	21281-446	6		AIR RLSE DRAIN LABEL	38816-333	1
48	MUFFLER 3"	29334-105	1		WARNING DECAL	38816-203	4
49	WEATHER CAP	S2021	1		FOAM TAPE 279" LG	18668-003	1
50	10" DIA MOUNTING BRKT	29334-288	2		RADIATOR DRAIN LABEL	38816-322	1
51	HEX HEAD CAP SCREW	B0505 15991	4		OIL DRAIN LABEL	38816-323	1
52	LOCK WASHER	J05 15991	4		WARNING DECAL	38816-345	2
53	HOIST BAIL ASSY	44713-067 24150	1		INSTRUCTION DECAL	38818-144	1
54	HEAT SHIELD ASSY	42381-145	1		EXHAUST BLANKET	46241-018	1
55	HEX HEAD CAP SCREW	B0605 15991	20		EXHST INSULTN WRAP	29330-441	2
56	LOCK WASHER	J06 15991	20		9" SNAP STRAP	29330-443	8
57	HEX HEAD CAP SCREW	B1006-1/2 15991	6		18" SNAP STRAP	29330-444	4

ILLUSTRATION

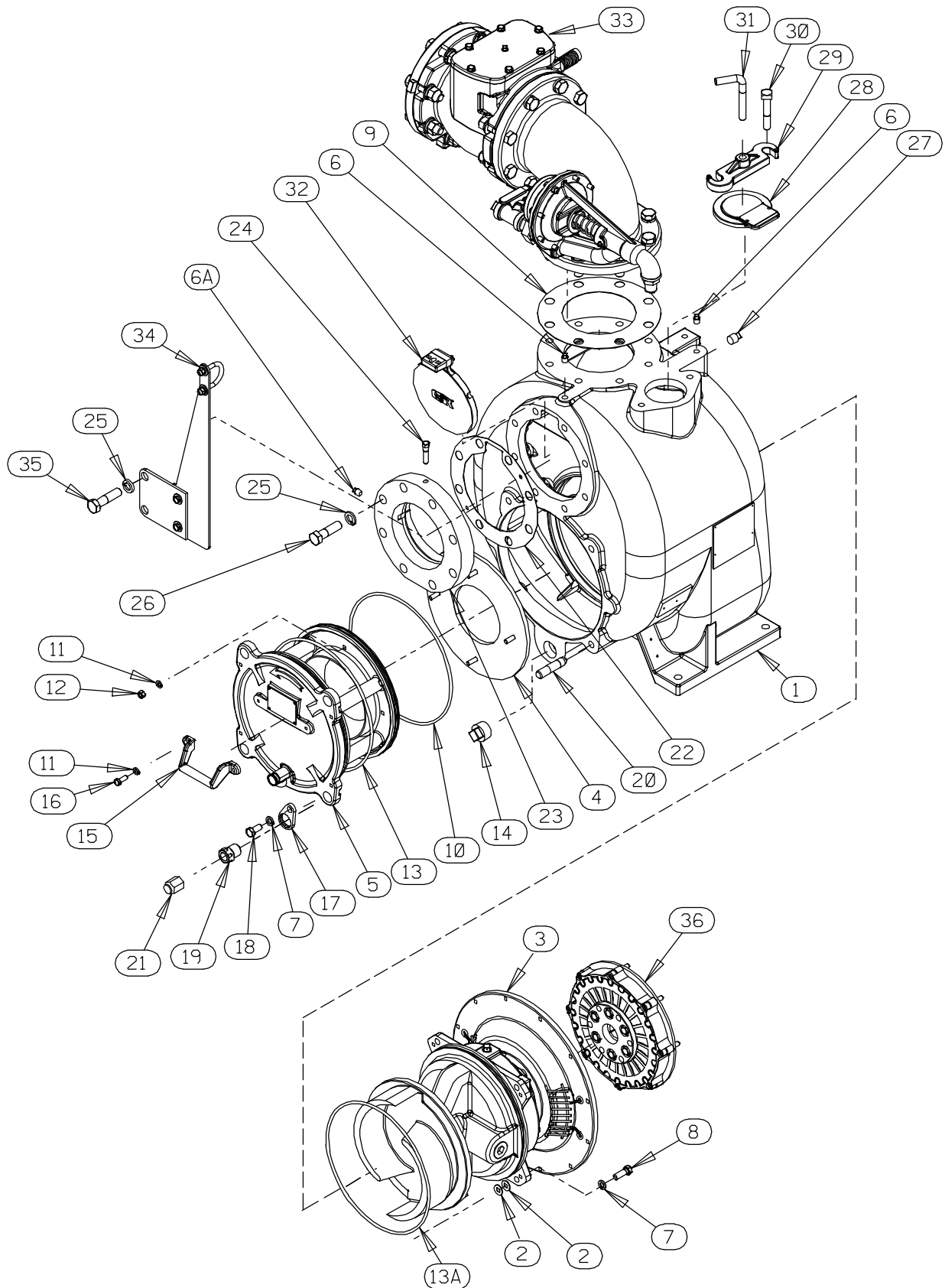

Figure 3. Pump End Assembly

PARTS LIST
Pump End Assembly

ITEM NO.	PART NAME	PART NUMBER	QTY	ITEM NO.	PART NAME	PART NUMBER	QTY
☞ 1	PUMP CASING	SEE NOTE BELOW	1	24	CHECK VALVE PIN	11645 17010	1
2	SHIM	13131-3 17040	8	25	LOCK WASHER	J12 15991	8
3	REPAIR ROTATING ASSY	44163-547	1	26	HEX HEAD CAP SCREW	B1211 15991	6
4 *	WEAR PLATE	46451-723 24150	1	☞27	PIPE PLUG	P08 15079	1
5	BACK CVR PLATE ASSY	42111-803	1	28	FILL COVER ASSY	42111-344	1
	-WARNING PLATE	2613EV 13990	1		-DRIVE SCREW	BM#04-03 17000	2
	-DRIVE SCREW	BM#04-03 17000	4		-WARNING PLATE	38816-097 13990	1
	-PRESS RELIEF VALVE	26662-005	1		-COVER GASKET	50G 19210	1
☞ 6	PIPE PLUG	P04 15079	2	29	CLAMP BAR	38111-004 11010	1
6A	PIPE PLUG	P04 15079	1	☞30	MACHINE BOLT	A1014 15991	2
7	LOCK WASHER	J08 15991	8	31	CLAMP BAR SCREW	31912-009 15000	1
8	HEX HEAD CAP SCREW	B0806 15991	4	32	FLAP VALVE ASSY	46411-064	1
9 *	GASKET	25113-036	1	33	CHK VLV/AIR REL ASSY	46421-100	1
10 *	O-RING	25152-453	1	34	MOUNTING BRKT ASSY	41888-286	1
11	LOCK WASHER	J06 15991	6	35	HEX HEAD CAP SCREW	B1212 15991	2
12	HEX NUT	D06 15991	4	36	COUPLING KIT	48112-001	1
13 *	O-RING	S1676	1	NOT SHOWN:			
13A *	O-RING	S1676	1		G-R DECAL	GR-06	1
☞14	CASING DRAIN PLUG	P20 10009	1		INSTR TAG	38817-085	1
15	HANDLE	12354 13010	1		LUBRICATION DECAL	38817-084	1
16	HEX HEAD CAP SCREW	B0604 15991	2		WARNING DECAL	2613FE	1
17	LOCK COLLAR	38115-551 15001	4		SUCTION STICKER	6588AG	1
18	HEX HEAD CAP SCREW	B0804-1/2 15991	4		PRIMING STICKER	6588AH	1
19	ADJUSTING SCREW	31871-070 1500G	4		DISCHARGE STICKER	6588BJ	1
☞20	STUD	C1213 15991	4		SUPER "T" DECAL	38812-089	1
21	BACK COVER NUT	31871-073 15000	4		NAME PLATE	38819-002 13000	1
22 *	SUCT FLANGE GASKET	11402G 19370	1		DRIVE SCREW	BM#04-03 17000	4
23	SUCTION FLANGE	11402 10010	1		STRAINER ASSY	7823A 24000	1

* INDICATES PARTS RECOMMENDED FOR STOCK

☞ INCLUDED WITH REPAIR 46472-722 1
PUMP CASING ASSY

ILLUSTRATION

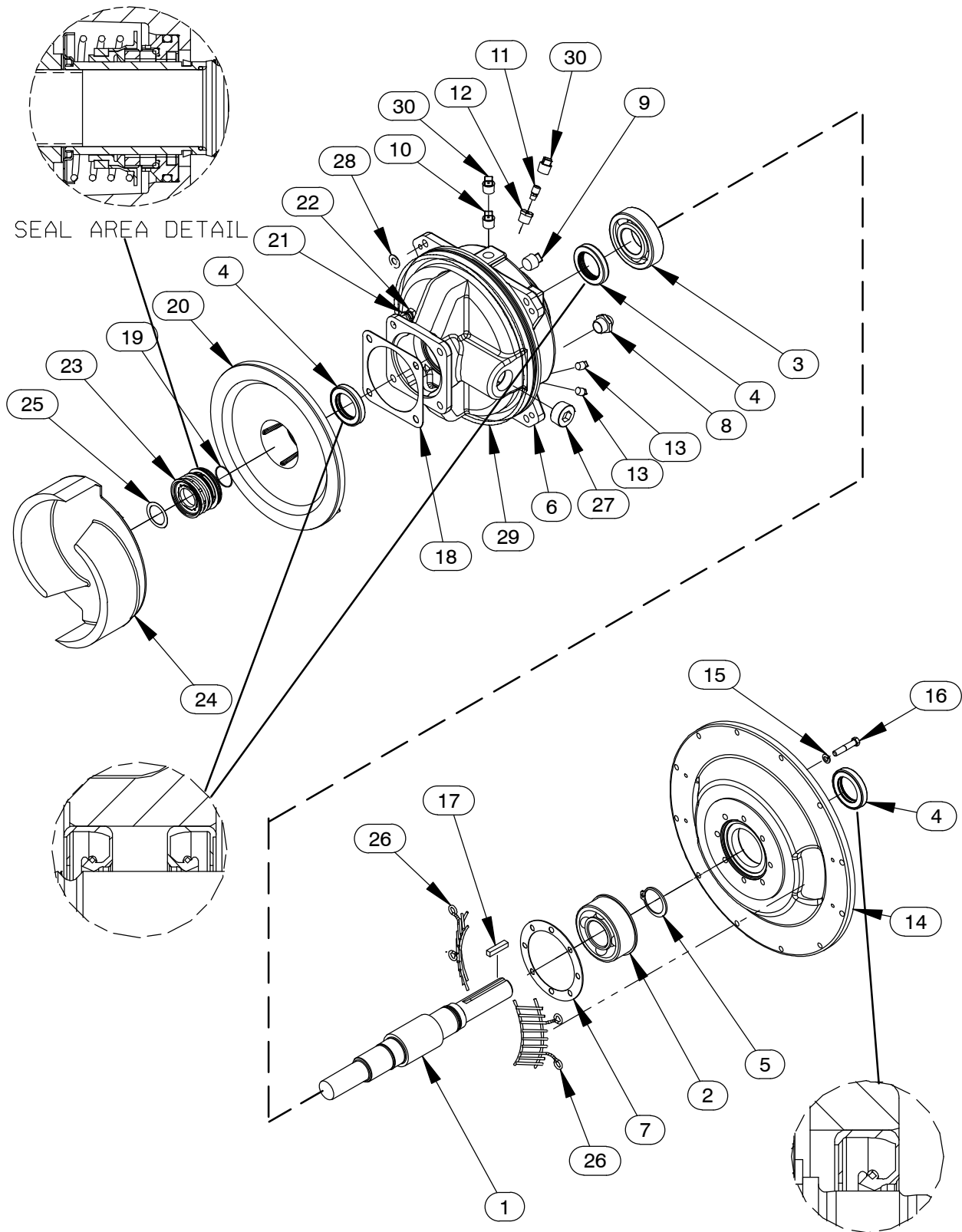

Figure 4. Repair Rotating Assembly

PARTS LIST
Repair Rotating Assembly

ITEM NO.		PART NAME	PART NUMBER	QTY
1	*	IMPELLER SHAFT	38514-823 1706H	1
2	*	BALL BEARING	S1030	1
3	*	BALL BEARING	S616	1
4	*	OIL SEAL	S1917	3
5		SNAP RING	24124-425	1
6		BEARING HOUSING	38251-517 10000	1
7	*	BEARING CAP GASKET	38683-478 18000	1
8		SIGHT GAUGE	S1471	2
9		PIPE PLUG	P12 15079	1
10		VENTED PIPE PLUG	4823A 15079	1
11		AIR VENT	S1530	1
12		REDUCER PIPE BUSHING	AP0802 15079	1
13		PIPE PLUG	P04 15079	2
14		DRIVE FLANGE	38545-023 10000	1
15		LOCK WASHER	J06 15991	8
16		GRADE 8 CAPSCREW 3/8 X 2	21632-938	8
17	*	SHAFT KEY	N0607 15990	1
18	*	GASKET	10959G 20000	1
19	*	SHAFT SLEEVE O-RING	25154-026	REF
20		SEAL PLATE	38272-254 10010	1
21		LOCK WASHER	J08 15991	4
22		HEX HEAD CAP SCREW	B0805-1/2 15991	4
23	*	1 7/8 CTG SEAL ASSY	46513-154	1
24		IMPELLER	38615-087 11010	1
25		ADJ SHIM SET	5091 17090	2
26		INTERMEDIATE GUARD	42381-509 24152	2
27		PIPE PLUG	PC20 10009	1
28	*	ROTATING ASSY ADJ SHIM	13131-3 17040	8
29	*	O-RING	S1676	1
30		SHIPPING PLUG	11495B 15079	2
NOT SHOWN:				
		ASSEMBLY PLATE	2613GG 13990	1
		DRIVE SCREW	BM#04-03 17000	2
		ROTATION DECAL	2613M	1
		INSTRUCTION DECAL	6588U	1
		WARNING DECAL	38817-102	1

* INDICATES PARTS RECOMMENDED FOR STOCK

ILLUSTRATION

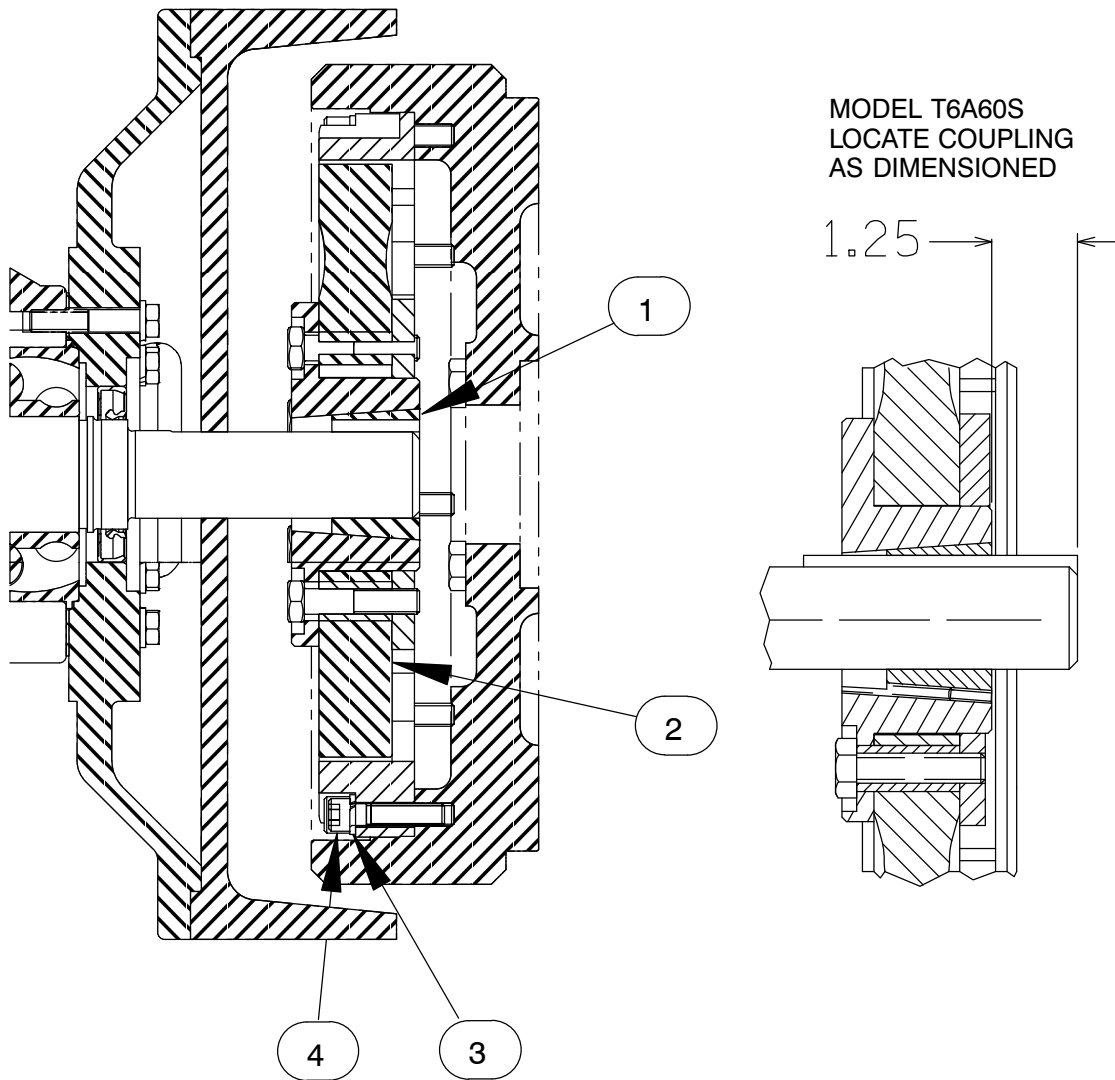







Figure 5. Coupling Kit
PARTS LIST

ITEM NO.	PART NAME	PART NUMBER	QTY
1	BUSHING	24131-345	1
2	COUPLING ASSEMBLY	44165-011	1
3	 LOCKWASHER	J06 15991	8
4	 SOCKET HD CAPSCREW	BD0606-1/2 15991	8
3	 LOCKWASHER	21171-536	8
4	 SOCKET HD CAPSCREW	22644-220	8
	 USE FOR SAE APPLICATIONS		
	 USE FOR METRIC APPLICATIONS		

PUMP AND SEAL DISASSEMBLY AND REASSEMBLY

Review all **SAFETY** information in Section A.

Follow the instructions on all tags, label and decals attached to the pump.

This pump requires little service due to its rugged, minimum-maintenance design. However, if it becomes necessary to inspect or replace the wearing parts, follow these instructions which are keyed to the illustrations (see Figures 1 through 5) and the accompanying parts lists.



This manual will alert personnel to known procedures which require special attention, to those which could damage equipment, and to those which could be dangerous to personnel. However, this manual cannot possibly anticipate and provide detailed instructions and precautions for every situation that might occur during maintenance of the unit. Therefore, it is the responsibility of the owner/maintenance personnel to ensure that only safe, established maintenance procedures are used, and that any procedures not addressed in this manual are performed only after establishing that neither personal safety nor pump integrity are compromised by such practices.

Many service functions may be performed by draining the pump and removing the back cover assembly. If major repair is required, the piping and/or engine must be disconnected. The following instructions assume complete disassembly is required.

Before attempting to service the pump, disconnect or lock out the power source and take precautions to ensure that it will remain inoperative. Close all valves in the suction and discharge lines.

No instructions for removal and/or disassembly of the enclosure or its components are provided in

this manual. If removal of the enclosure is required for pump service, be sure to use safe shop practices so as not to endanger personnel, and use caution to prevent damage to the enclosure.

For engine disassembly and repair, consult the literature supplied with the engine, or contact your local engine representative.



Before attempting to open or service the pump:

1. Familiarize yourself with this manual.
2. Switch off the engine ignition and disconnect the positive battery cable to ensure that the pump will remain inoperative.
3. Allow the pump to completely cool if overheated.
4. Check the temperature before opening any covers, plates, or plugs.
5. Close the suction and discharge valves.
6. Vent the pump slowly and cautiously.
7. Drain the pump.



Death or serious personal injury and damage to the pump or components can occur if proper lifting procedures are not observed. Make certain that hoists, chains, slings or cables are in good working condition and of sufficient capacity and that they are positioned so that loads will be balanced and the pump or components will not be damaged when lifting. Suction and discharge hoses and piping must be removed from the pump before lifting. Lift the pump or component only as high as necessary and keep personnel away from suspended objects.



Use **Only Genuine Gorman-Rupp** replacement parts. Failure to do so may create a hazard and damage the pump or diminish optimal pump performance. Any such hazard, damage or diminished performance is not covered by the warranty.

NOTE

When appropriate recycling facilities are available, the user should recycle components and fluids when doing any routine maintenance / repairs and also at the end of the pump's useful life. All other components and fluids shall be disposed of according to all applicable codes and regulations.

Back Cover and Wear Plate Removal

(Figure 3)

The wear plate (4) is easily accessible and may be serviced by removing the back cover assembly (5). Before attempting to service the pump, open the ball valve (87, Figure 2) and drain the pump. Close the valve after draining is complete.

Remove the back cover nuts (21) and pry the back cover and assembled wear plate from the pump casing (1).

NOTE

An alternate method of removing the back cover from the pump casing is to remove the back cover nuts (21) and two diagonally opposing locking collars (17). Install two 1/2-16 UNC x 2 inch long screws in the tapped holes in the back cover and use them to press the back cover out of the pump casing.

Inspect the wear plate and replace it if badly scored or worn. To remove the wear plate, disengage the hardware (11 and 12).

Inspect the back cover and wear plate O-rings (10 and 13) and replace them if damaged or worn.

Suction Check Valve Removal

(Figure 3)

If the check valve assembly (32) is to be serviced, remove the check valve pin (24), reach through the back cover opening and pull the complete assembly from the suction flange (23).

NOTE

Further disassembly of the check valve is not required since it must be replaced as a complete unit. Individual parts are not sold separately.

Separating Intermediate and Coupling Assembly From Engine

(Figure 5)

Further disassembly requires separating the pump end and drive assembly from the engine. Remove the hardware securing the check valve/air release valve assembly (33, Figure 3) to the pump casing. Disengage and remove any additional components necessary for the removal of the pump end.

Install a standard 5/8-11 UNC lifting eye in the tapped hole in the top of the pump casing. **Be sure** to screw the eye into the casing until fully engaged. Support the pump using a suitable hoist and the lifting eye.



Do not attempt to lift the complete pump unit using the lifting eye. It is designed to facilitate removal or installation of individual components only. Additional weight may result in damage to the pump or failure of the eye bolt.

Remove the hardware securing the pump casing to the base.

Disengage the hardware (7 and 8, Figure 3) securing the drive flange to the engine bellhousing, and remove the guards (26, Figure 4). Separate the pump end and drive assembly from the engine by pulling the pump end straight away from the engine.

As the assemblies separate, the flexible portion of the coupling assembly (2) will remain on the shaft.

To remove the coupling from the shaft, unscrew the two allen head setscrews from the bushing (1). Screw one of the setscrews into the puller hole on the circumference of the bushing. As the coupling and bushing separate, remove the bushing, and slide the coupling off the shaft. Remove the shaft key (17, Figure 4).

It is not necessary to remove the outer ring of the coupling from the engine flywheel unless the coupling must be replaced. To remove the ring, disengage the hardware (3 and 4) securing it to the flywheel.

Remove any leveling shims used under the casing mounting feet. Tie and tag the shims for ease of reassembly.

Move the pump end to a clean, well equipped shop area for further disassembly.

Loosening Impeller

(Figure 4)

Before attempting to loosen the impeller, remove the seal cavity drain plug (13) and drain the lubricant. This will prevent the oil from escaping as the impeller is removed. Clean and reinstall the drain plug.

With the pump end separated from the engine and the back cover (5, Figure 3) removed, wedge a block of wood between the vanes of the impeller and the pump casing to prevent rotation.

If removed, install the shaft key (17) in the shaft keyway. Install a lathe dog on the drive end of the

shaft (1) with the "V" notch positioned over the shaft key.

With the impeller rotation still blocked, see Figure 6 and use a long piece of heavy bar stock to pry against the arm of the lathe dog in a counterclockwise direction (when facing the drive end of the shaft). **Use caution** not to damage the shaft or keyway. When the impeller breaks loose, remove the lathe dog, key and wood block.

NOTE

Do not remove the impeller until the rotating assembly has been removed from the pump casing.

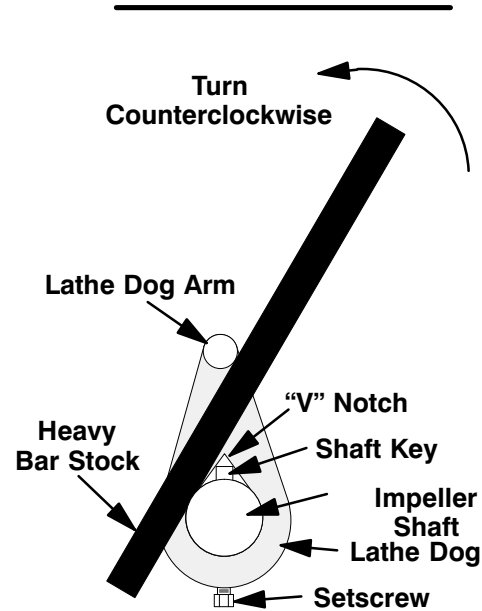

Figure 6. Loosening Impeller

Rotating Assembly Removal (Figure 3)

Remove the hardware (7 and 8) securing the rotating assembly to the pump casing. Separate the rotating assembly by pulling straight away from the pump casing. Tie and tag the rotating assembly shims (2) for ease of reassembly.

NOTE

An optional disassembly tool is available from the factory. If the tool is used, follow the instructions packed with it. A similar tool may be assembled using 1/2-inch pipe (schedule 80 steel or malleable iron) and a standard tee (see Figure 7). All threads are 1/2-inch NPT. **Do not pre-assemble the tool.**

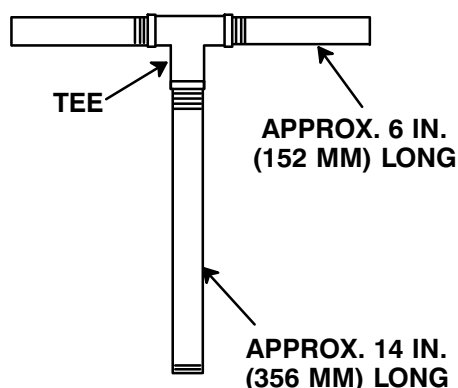

Figure 7. Rotating Assembly Tool

To install the tool, remove the vented plug (10, Figure 4) from the bearing housing, and screw the longest length of pipe into the vent hole until fully engaged. Install the tee, and screw the handles into the tee. Use caution when lifting the rotating assembly to avoid injury to personnel or damage to the assembly.

Remove the bearing housing O-ring (13A).

Impeller Removal

(Figure 4)

With the rotating assembly removed from the pump casing, unscrew the impeller from the shaft. Use caution when unscrewing the impeller; tension on the shaft seal spring will be released as the impeller is removed. Inspect the impeller and replace if cracked or badly worn.

Remove the impeller adjusting shims (25); tie and tag the shims, or measure and record their thickness for ease of reassembly.

Seal Removal

(Figure 4)

Slide the integral shaft sleeve and rotating portion of the seal off the shaft as a unit.

Use a pair of stiff wires with hooked ends to remove the stationary element and seat.

An alternate method of removing the stationary seal components is to remove the hardware (21 and 22) and separate the seal plate (20) and gasket (18) from the bearing housing (6). Position the seal plate on a flat surface with the impeller side down. Use a wooden dowel or other suitable tool to press on the back side of the stationary seat until the seat, O-rings, and stationary element can be removed.

Remove the shaft sleeve O-ring (19).

If no further disassembly is required, refer to **Seal Installation**.

Shaft and Bearing Removal and Disassembly

(Figure 4)

When the pump is properly operated and maintained, the bearing housing should not require disassembly. Disassemble the shaft and bearings **only** when there is evidence of wear or damage.



Shaft and bearing disassembly in the field is not recommended. These operations should be performed only in a properly-equipped shop by qualified personnel.

Remove the bearing housing drain plug (13) and drain the lubricant. Clean and reinstall the drain plug.

Disengage the hardware (15 and 16) and slide the drive flange (14) and oil seal (4) off the shaft. Remove the flange gasket (7) and press the oil seal from the drive flange.

Place a block of wood against the impeller end of the shaft and tap the shaft and assembled bearings (2 and 3) from the bearing housing.

Pry or press the oil seals (4) from the bearing housing.

After removing the shaft and bearings, clean and inspect the bearings **in place** as follows.



To prevent damage during removal from the shaft, it is recommended that bearings be cleaned and inspected **in place**. It is **strongly** recommended that the bearings be replaced **any** time the shaft and bearings are removed.

Clean the bearing housing, shaft and all component parts (except the bearings) with a soft cloth soaked in cleaning solvent. Inspect the parts for wear or damage and replace as necessary.



Most cleaning solvents are toxic and flammable. Use them only in a well ventilated area free from excessive heat, sparks, and flame. Read and follow all precautions printed on solvent containers.

Clean the bearings thoroughly in **fresh** cleaning solvent. Dry the bearings with filtered compressed air and coat with light oil.



Bearings must be kept free of all dirt and foreign material. Failure to do so will greatly shorten bearing life. **Do not** spin dry bearings. This may scratch the balls or races and cause premature bearing failure.

Rotate the bearings by hand to check for roughness or binding and inspect the bearing balls. If rotation is rough or the bearing balls are discolored, replace the bearings.

The bearing tolerances provide a tight press fit onto the shaft and a snug slip fit into the bearing

housing. Replace the bearings, shaft, or bearing housing if the proper bearing fit is not achieved.

If bearing replacement is required, remove the outboard bearing snap ring (5) and use a bearing puller to remove the bearings from the shaft.

Shaft and Bearing Reassembly and Installation (Figure 4)

Clean the bearing housing, shaft and all component parts (except the bearings) with a soft cloth soaked in cleaning solvent. Inspect the parts for wear or damage as necessary.



Most cleaning solvents are toxic and flammable. Use them only in a well ventilated area free from excessive heat, sparks, and flame. Read and follow all precautions printed on solvent containers.

Inspect the shaft for distortion, nicks or scratches, or for thread damage on the impeller end. Dress small nicks and burrs with a fine file or emery cloth. Replace the shaft if defective.

Position the inboard oil seal (4) in the bearing housing bore with the lip positioned as shown in Figure 5. Press the oil seal into the housing until the face is **just flush** with the machined surface on the inside of the housing.

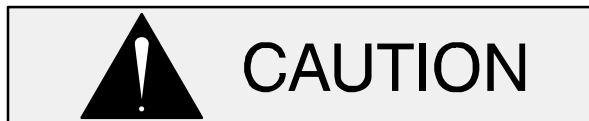

To prevent damage during removal from the shaft, it is recommended that bearings be cleaned and inspected **in place**. It is **strongly** recommended that the bearings be replaced **any** time the shaft and bearings are removed.

NOTE

Position the inboard bearing (3) on the shaft with the shielded side toward the impeller end of the shaft. Position the outboard bearing (2) on the shaft with the integral retaining ring on the bearing O.D. toward the drive end of the shaft.

The bearings may be heated to ease installation. An induction heater, hot oil bath, electric oven, or hot plate may be used to heat the bearings. Bearings should **never** be heated with a direct flame or directly on a hot plate.

NOTE

*If a hot oil bath is used to heat the bearings, both the oil and the container must be **absolutely** clean. If the oil has been previously used, it must be **thoroughly** filtered.*

Heat the bearings to a uniform temperature **no higher than 250°F (120°C)** and slide the bearings onto the shaft, one at a time, until they are fully seated. This should be done quickly, in one continuous motion, to prevent the bearings from cooling and sticking on the shaft.

After the bearings have been installed and allowed to cool, check to ensure that they have not moved away from the shaft shoulders in shrinking. If movement has occurred, use a suitably sized sleeve and a press to reposition the bearings against the shaft shoulders.

If heating the bearings is not practical, use a suitably sized sleeve, and an arbor (or hydraulic) press to install the bearings on the shaft.



When installing the bearings onto the shaft, **never** press or hit against the outer race, balls, or ball cage. Press **only** on the inner race.

Secure the outboard bearing on the shaft with the bearing snap ring (5).

It is recommended that a sleeve be positioned against the inboard oil seal (4) to prevent the lip of the oil seal from rolling as the shaft and bearings are installed in the bearing housing. The O.D. of the sleeve should be just smaller than the bearing housing bore, while the I.D. of the sleeve should be just larger than the O.D. of the lip seal area of the shaft.

With the lip seal sleeve in place, lubricate the lip seal area of the shaft, and slide the shaft and assembled bearings into the bearing housing until the retaining ring on the outboard bearing seats against the bearing housing. Remove the lip seal sleeve.



When installing the shaft and bearings into the bearing bore, push against the outer race. **Never** hit the balls or ball cage.

Position the outboard oil seal (4) on the lubricated shaft with the lip positioned as shown in Figure 4. Press the oil seal into the bearing housing until the face of the seal is **just flush** with the machined surface on the bearing housing.

Press the oil seal (4) into the drive flange (14) with the lip positioned as shown in Figure 4. Replace the flange gasket (7) and secure the flange to the bearing housing with the hardware (15 and 16). **Be careful** not to damage the oil seal lip on the shaft keyway.

Lubricate the bearing housing as indicated in **LUBRICATION**.

Seal Installation

(Figures 4, 8, 9 and 10)



Most cleaning solvents are toxic and flammable. Use them only in a well ventilated area free from excessive heat, sparks, and flame. Read and follow all precautions printed on solvent containers.

Clean the seal cavity and shaft with a cloth soaked in fresh cleaning solvent. Inspect the stationary seat bore in the seal plate for dirt, nicks and burrs, and remove any that exist. The stationary seat bore **must** be completely clean before installing the seal.



A new seal assembly should be installed **any time** the old seal is removed from the pump. Wear patterns on the finished faces

cannot be realigned during reassembly. Reusing an old seal could result in premature failure.

To ease installation of the seal, lubricate the shaft sleeve O-ring (19) and the external stationary seat O-ring with a very **small** amount of light lubricating oil. See Figure 8 for seal part identification.

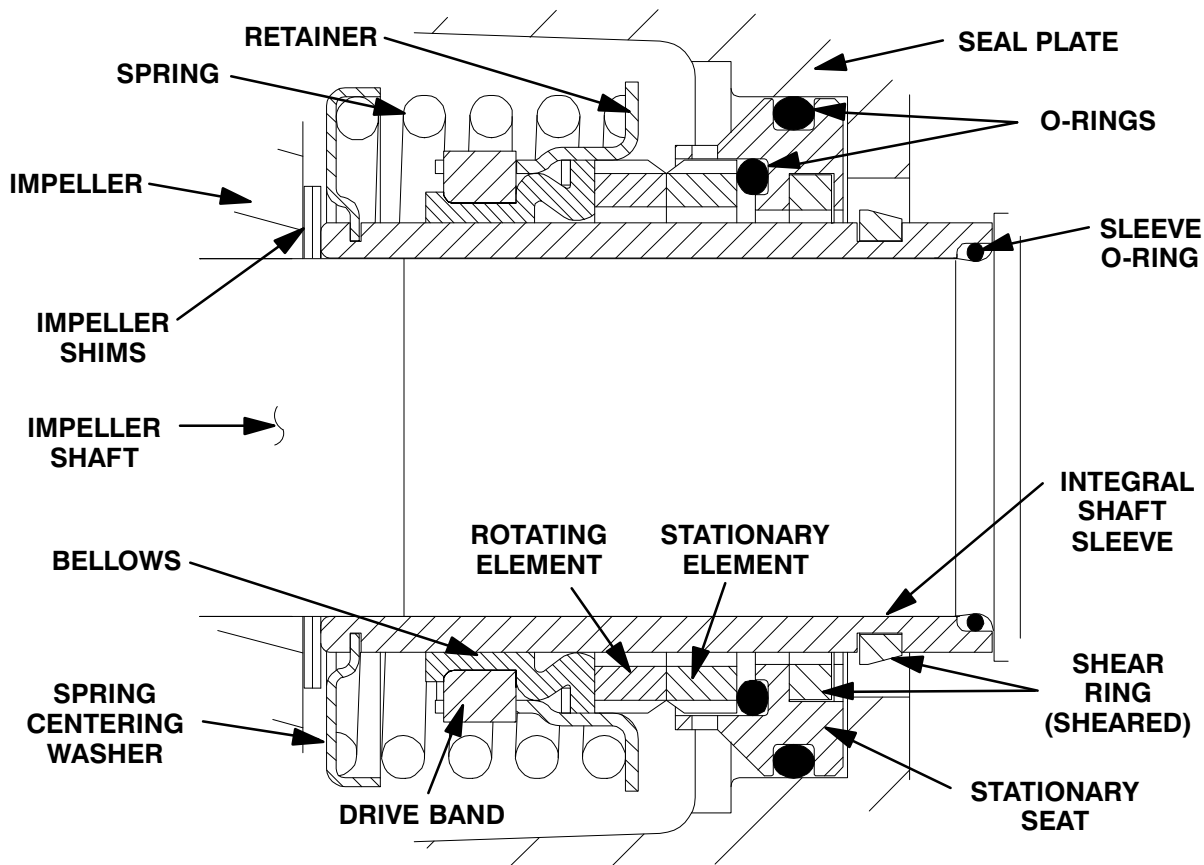
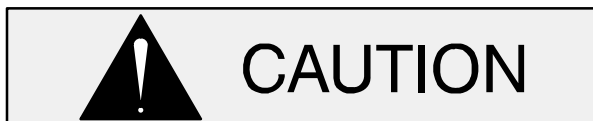

Figure 8. Cartridge Seal Assembly



This seal is not designed for operation at temperatures above 160°F (71°C). Do not use at higher operating temperatures.

If the seal plate (20) was removed, install the seal plate gasket (18), position the seal plate over the shaft and secure it to the bearing housing with the hardware (21 and 22). Install the bearing housing O-ring (29) and lubricate it with light grease.

To prevent damaging the shaft sleeve O-ring (19) on the shaft threads, cover the threads with electrical or duct tape. Slide the O-ring over the shaft until it seats against the shaft shoulder. Remove the

tape covering the threads. Check to ensure that the shaft threads are free of any tape residue and clean as required before proceeding with seal installation.

When installing a new cartridge seal assembly, remove the seal from the container lubricate the external stationary seat O-ring with light oil. Slide the seal assembly onto the shaft until the external stationary seat O-ring engages the bore in the seal plate.

Clean and inspect the impeller as described in **Impeller Installation and Adjustment.** Install the full set of impeller shims (25) provided with the seal, and screw the impeller onto the shaft until it is seated against the seal (see Figure 9).

Continue to screw the impeller onto the shaft. This will press the stationary seat into the seal plate bore.

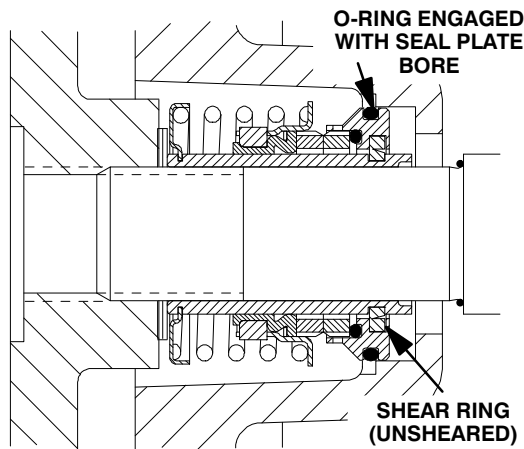

Figure 9. Seal Partially Installed

NOTE

A firm resistance will be felt as the impeller presses the stationary seat into the seal plate bore.

As the stationary seat becomes fully seated, the seal spring compresses, and the shaft sleeve will break the nylon shear ring. This allows the sleeve to slide down the shaft until seated against the shaft shoulder. Continue to screw the impeller onto the shaft until the impeller, shims, and sleeve are fully seated against the shaft shoulder (see Figure 10).

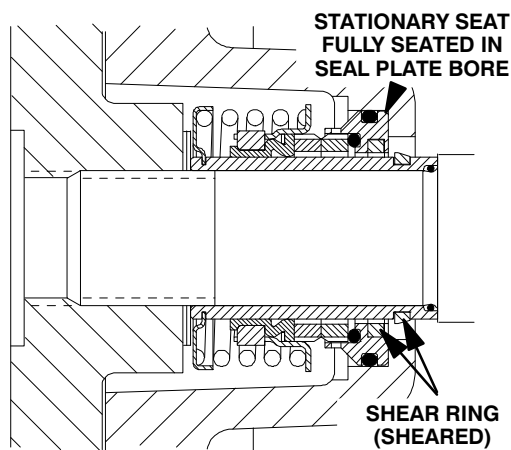
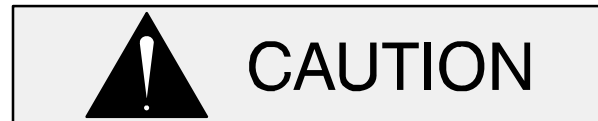

Figure 10. Seal Fully Installed

Measure the impeller-to-seal plate clearance, and remove impeller adjusting shims to obtain the

proper clearance as described in **Impeller Installation and Adjustment**.

If necessary to reuse an old seal in an emergency, carefully separate the rotating and stationary seal faces from the bellows retainer and stationary seat.



A new seal assembly should be installed **any time** the old seal is removed from the pump. Wear patterns on the finished faces cannot be realigned during reassembly. Reusing an old seal could result in premature failure.

Handle the seal parts with extreme care to prevent damage. Be careful not to contaminate precision finished faces; even fingerprints on the faces can shorten seal life. If necessary, clean the faces with a non-oil based solvent and a clean, lint-free tissue. Wipe **lightly** in a concentric pattern to avoid scratching the faces.

Carefully wash all metallic parts in fresh cleaning solvent and allow to dry thoroughly.



Do not attempt to separate the rotating portion of the seal from the shaft sleeve when reusing an old seal. The rubber bellows will adhere to the sleeve during use, and attempting to separate them could damage the bellows.

Inspect the seal components for wear, scoring, grooves, and other damage that might cause leakage. Inspect the integral shaft sleeve for nicks or cuts on either end. If any components are worn, or the sleeve is damaged, replace the complete seal; **never mix old and new seal parts**.

Install the stationary seal element in the stationary seat. Press this stationary subassembly into the seal plate bore until it seats squarely against the bore shoulder. A push tube made from a piece of plastic pipe would aid this installation. The I.D. of the pipe should be slightly larger than the O.D. of the shaft sleeve.

Slide the rotating portion of the seal (consisting of the integral shaft sleeve, spring centering washer, spring, bellows and retainer, and rotating element) onto the shaft until the seal faces contact.

Proceed with **Impeller Installation and Adjustment**.

Impeller Installation and Adjustment

(Figure 4)

Inspect the impeller, and replace it if cracked or badly worn. Inspect the impeller and shaft threads for dirt or damage, and clean or dress the threads as required.



The shaft and impeller threads **must** be completely clean before reinstalling the impeller. Even the slightest amount of dirt on the threads can cause the impeller to seize to the shaft, making future removal difficult or impossible without damage to the impeller or shaft.

Install the same thickness of impeller adjusting shims (25) as previously removed. Apply 'Never-Seez' or equivalent to the shaft threads and screw the impeller onto the shaft until tight. Be sure the seal spring seats squarely on the back side of the impeller.

NOTE

At the slightest sign of binding, immediately back the impeller off, and check the threads for dirt. Do not try to force the impeller onto the shaft.

A clearance of .025 to .040 inch (0,64 to 1,02 mm) between the impeller and the seal plate is recommended for maximum pump efficiency. Measure this clearance, and add or remove impeller adjusting shims as required.

NOTE

If the rotating assembly has been installed in the pump casing, this clearance may be measured by reaching through the priming port with a feeler gauge.

Rotating Assembly Installation

(Figure 3)

NOTE

If the pump has been completely disassembled, it is recommended that the suction check valve and back cover assembly be reinstalled at this point. The back cover assembly must be in place to adjust the impeller face clearance.

NOTE

There is a 1-1/2 inch diameter socket head pipe plug located in the side of the bearing housing. This hole is required for manufacturing purposes only; therefore the pipe plug should never require removal.

Install the bearing housing O-ring (13A) and lubricate it with light grease. Ease the rotating assembly into the pump casing using the installation tool. **Be careful** not to damage the O-ring.

Install the rotating assembly adjusting shims (2) using the same thickness as previously removed. Secure the rotating assembly to the pump casing with the hardware (7 and 8).

To set the impeller and wear plate clearance refer to the **Back Cover Installation And Adjustment**.

Suction Check Valve Installation

(Figure 3)

Inspect the check valve assembly (32) and replace it if badly worn.

NOTE

The check valve assembly must be replaced as a complete unit. Individual parts are not sold separately.

Reach through the back cover opening with the check valve and position the check valve adaptor in the mounting slot in the suction flange (23). Align the adaptor with the flange hole and secure the assembly with the check valve pin (24).

NOTE

If the suction or discharge flanges were removed, replace the respective gaskets, apply 'Permatex

Aviation No. 3 Form-A-Gasket' or equivalent compound to the mating surfaces, and secure them to the pump casing with the attaching hardware.

Back Cover Installation and Adjustment

(Figures 3 and 11)

If the wear plate (4) was removed for replacement, carefully center it on the back cover and secure it with the hardware (11 and 12). The wear plate **must** be concentric to prevent binding when the back cover is installed.

The clearance between the impeller and wear plate is adjusted using four adjusting screws (19) and locking collars (17). There are 18 detents on the I.D. of each locking collar. Indexing the collars one detent on the adjusting screws represents approximately .005 inch (0,13 mm) of wear plate clearance. The recommended clearance between the wear plate and the impeller is .010 to .020 inch (0,25 to 0,50 mm).

Replace the back cover and wear plate O-rings (10 and 13) and lubricate them with a generous amount of No. 2 grease. Clean any scale or debris from the contacting surfaces in the pump casing that might interfere or prevent a good seal with the back cover.

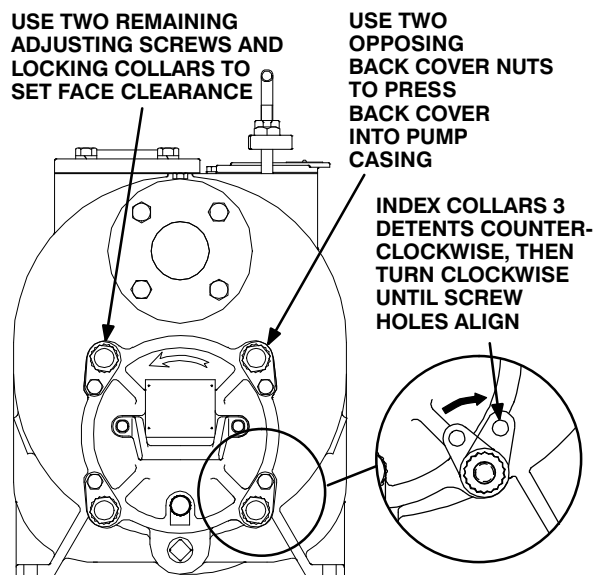

Figure 11. Installing and Adjusting Back Cover

Screw the four adjusting screws (19) into the tapped holes in the back cover plate until they are

just flush with the machined surface on the back side of the cover plate.

Align the back cover plate over the studs (20) and slide it into the pump casing. Use two back cover nuts (21) on diagonally opposing studs to press the back cover into the pump casing until the wear plate **just touches** the impeller when the shaft is turned by hand. **Tighten the back cover nuts evenly to avoid binding.**

With the wear plate just touching the impeller, turn the two free adjusting screws until they engage the pump casing. Position the locking collars over the adjusting screws so the holes in the collars for the locking screws align approximately with the holes in the cover plate.

Loosen the back cover nuts used to press the back cover into the pump casing one full turn.

Pull the collars off the adjusting screws, index them three detents counterclockwise, and reinstall the collars on the adjusting screws. Use the collars to turn the adjusting screws clockwise until the holes in the locking collars realign with the tapped screw holes in the back cover plate. Secure the locking collars to the back cover plate with the hardware (7 and 18). Install the two remaining back cover nuts snugly against the adjusting screws.

Remove the first two back cover nuts from their studs. Turn the adjusting screws clockwise until they engage the pump casing. Install the locking collars and hardware (7 and 18). Reinstall the back cover nuts.

Be sure the wear plate does not scrape against the impeller.

Over time it may be necessary to repeat the adjustment process to compensate for normal wear between the impeller and wear plate. When all of the adjustment has been used on the back cover side of the pump, an additional 0.125 inch (3,2 mm) of adjustment may be obtained by removing the rotating assembly adjusting shims (2).

Allow an installed pump to completely cool before draining liquid from the pump casing. Remove the back cover. Remove the rotating assembly adjusting shims, then reinstall the hardware securing the rotating assembly to the pump casing. Perform the back cover adjustment procedure described above to obtain the proper face clearance.

Securing Pump and Coupling Assembly to Engine

(Figure 5)

Install the shaft key (17, Figure 4) in the shaft keyway. Position the flexible portion of the coupling assembly (2) on the shaft as shown in Figure 5.

Align the keyway in the bushing (1) with the shaft key, and slide it onto the shaft to the dimension shown in Figure 8. Rotate the flexible portion of the coupling until the tapped holes for the two setscrews align with those in the bushing, and install the setscrews.



Make certain that the flexible portion of the coupling is mounted as shown in Figure 5. **This is critical.** If the coupling is not properly positioned on the shaft, the coupling parts may not fully engage, or a pre-load condition can cause premature bearing failure.

The end of the shaft must protrude 1.25 inch (32 mm) from the face of the bushing. This will allow the two portions of the coupling to fully engage when the drive flange is secured to the engine bellhousing, without pre-loading the bearings.

With the flexible portion of the coupling and the bushing properly positioned on the shaft, tighten the two setscrews in an alternating sequence until the bushing and coupling are fully secured. Torque the setscrews to 14.6 ft. lbs. (175 in. lbs. or 2 m. kg.).

If the complete coupling assembly is being replaced, apply 'Loctite Retaining Compound No. 242' or equivalent to the threads of the hardware (3 and 4) and secure the outer ring of the coupling to the engine flywheel by torquing the hardware to 45 ft. lbs. (540 in. lbs. or 6,2 m. kg.).

Using a suitable lifting device, position the pump end so the flexible portion of the coupling seats inside the outer ring attached to the engine flywheel.

NOTE

To ease installation, **lightly** lubricate the rubber portion of the coupling with a **non-petroleum based lubricant** such as vegetable oil or glycerin, or a **silicon-based lubricant** such as "WD40" or equivalent. **Do not** use petroleum-based lubricants, or any other substance which may soften or otherwise damage the rubber.

Install the intermediate guards (26, Figure 4), and secure the drive flange to the engine bellhousing with the hardware (7 and 8, Figure 3).

Secure the check valve/air release valve assembly (33, Figure 3) to the pump casing using the previously removed hardware. Reinstall any additional components removed at disassembly.

Install any leveling shims used under the casing mounting feet, and secure the casing to the base with the previously removed hardware.

If a lifting eye was used to move the pump casing, **be sure** to remove the lifting eye from the pump casing.



Do not attempt to lift the complete pump unit using the lifting eye. It is designed to facilitate removal or installation of individual components only. Additional weight may result in damage to the pump or failure of the eye bolt.

PRESSURE RELIEF VALVE MAINTENANCE

(Figure 3)

The back cover is equipped with a pressure relief valve (not shown) to provide additional safety for the pump and operator (refer to **Liquid Temperature And Overheating** in **OPERATION**).

It is recommended that the pressure relief valve assembly be replaced at each overhaul, or any time the pump overheats and activates the valve. **Never** replace this valve with a substitute which has not

been specified or provided by the Gorman-Rupp Company.

Periodically, the valve should be removed for inspection and cleaning. When reinstalling the relief valve, apply 'Loctite Pipe Sealant With Teflon No. 592', or equivalent compound, on the relief valve threads. Position the valve as shown in Figure 3 with the discharge port pointing down.

Final Pump Assembly

Be sure the pump is secured to the base and engine. Be sure to install any guards used over the rotating members.



Do not operate the pump without the guards in place over the rotating parts. Exposed rotating parts can catch clothing, fingers, or tools, causing severe injury to personnel.

Install the suction and discharge lines and open all valves. Make certain that all piping connections are tight, properly supported and secure.

Be sure the pump and engine have been properly lubricated, see **LUBRICATION**.

Remove the fill cover assembly (28, Figure 3) and fill the pump casing with clean liquid. Reinstall the fill cover and tighten it. Refer to **OPERATION**, Section C, before putting the pump back into service.

LUBRICATION

Seal Assembly

(Figure 4)

Before starting the pump, remove the vented plug (10) and fill the seal cavity with approximately 64

ounces (1,9 liter) of SAE No. 30 non-detergent oil to the middle of the sight gauge (8) and maintain it at the middle of the gauge. Clean and reinstall the vented plug. Maintain the oil at this level.

Bearings

(Figure 4)

The bearing housing was fully lubricated when shipped from the factory. Check the oil level regularly through the sight gauge (8) and maintain it at the middle of the gauge. When lubrication is required, add SAE No. 30 non-detergent-oil through the hole for the air vent (11). **Do not** over-lubricate. Over-lubrication can cause the bearings to over-heat, resulting in premature bearing failure.

Under normal conditions, drain the bearing housing once each year and refill with approximately 21 ounces (0,6 liter) clean oil. Change the oil more frequently if the pump is operated continuously or installed in an environment with rapid temperature change.



Monitor the condition of the bearing lubricant regularly for evidence of rust or moisture condensation. This is especially important in areas where variable hot and cold temperatures are common.

For cold weather operation, consult the factory or a lubricant supplier for the recommended grade of oil.

Engine

Consult the literature supplied with the engine, or contact your local engine representative.

**For Warranty Information, Please Visit
www.grpumps.com/warranty
or call:
U.S.: 419-755-1280
Canada: 519-631-2870
International: +1-419-755-1352**

GORMAN-RUPP PUMPS