

**INSTALLATION, OPERATION,  
AND MAINTENANCE MANUAL**  
WITH PARTS LIST



VPA SERIES<sup>®</sup> PUMP

MODEL
<b>VPA4A60C-3CH1 FT4</b>

**GORMAN-RUPP PUMPS**

[www.grpumps.com](http://www.grpumps.com)

Register your new  
Gorman-Rupp pump online at  
**www.grpumps.com**

Valid serial number and e-mail address required.



**The engine exhaust from this product contains chemicals known to the State of California to cause cancer, birth defects or other reproductive harm.**

### **RECORD YOUR PUMP MODEL AND SERIAL NUMBER**

Please record your pump model and serial number in the spaces provided below. Your Gorman-Rupp distributor needs this information when you require parts or service.

Pump Model: \_\_\_\_\_

Serial Number: \_\_\_\_\_

# TABLE OF CONTENTS

<b>INTRODUCTION</b> .....	<b>PAGE I – 1</b>
<b>SAFETY - SECTION A</b> .....	<b>PAGE A – 1</b>
<b>INSTALLATION – SECTION B</b> .....	<b>PAGE B – 1</b>
Pump Dimensions .....	PAGE B – 1
PREINSTALLATION INSPECTION .....	PAGE B – 2
Battery Specifications And Installation .....	PAGE B – 2
POSITIONING PUMP .....	PAGE B – 2
Lifting .....	PAGE B – 2
Mounting .....	PAGE B – 2
SUCTION AND DISCHARGE PIPING .....	PAGE B – 3
Materials .....	PAGE B – 3
Line Configuration .....	PAGE B – 3
Connections to Pump .....	PAGE B – 3
Gauges .....	PAGE B – 3
SUCTION LINES .....	PAGE B – 3
Fittings .....	PAGE B – 3
Strainers .....	PAGE B – 3
Sealing .....	PAGE B – 4
Suction Lines In Sumps .....	PAGE B – 4
Suction Line Positioning .....	PAGE B – 4
DISCHARGE LINES .....	PAGE B – 5
Siphoning .....	PAGE B – 5
Valves .....	PAGE B – 5
ALIGNMENT .....	PAGE B – 5
AUTO–START .....	PAGE B – 5
Float Switch Installation .....	PAGE B – 5
COLD WEATHER INSTALLATION .....	PAGE B – 6
<b>OPERATION – SECTION C</b> .....	<b>PAGE C – 1</b>
OPERATION .....	PAGE C – 1
PRIMING .....	PAGE C – 1
STARTING .....	PAGE C – 1
ROUTINE OPERATION .....	PAGE C – 2
OPERATION IN EXTREME HEAT .....	PAGE C – 2
OPERATIONAL CHECKS .....	PAGE C – 3
Leakage .....	PAGE C – 3
Pump Vacuum Check .....	PAGE C – 3
Liquid Temperature And Overheating .....	PAGE C – 3
Strainer Check .....	PAGE C – 3
STOPPING .....	PAGE C – 3
Manual Stopping .....	PAGE C – 3
Automatic Stopping .....	PAGE C – 4
Safety Shutdown System .....	PAGE C – 4
PERIODIC CHECKS .....	PAGE C – 4
Seal Cavity and Bearing Lubrication .....	PAGE C – 4
Bearing Temperature Check .....	PAGE C – 4

**TABLE OF CONTENTS**  
**(continued)**

Air Compressor .....	PAGE C – 5
Additional Checks .....	PAGE C – 5
COLD WEATHER PRESERVATION .....	PAGE C – 5
<b>TROUBLESHOOTING – SECTION D .....</b>	<b>PAGE D – 1</b>
PREVENTIVE MAINTENANCE .....	PAGE D – 3
<b>PUMP MAINTENANCE AND REPAIR - SECTION E .....</b>	<b>PAGE E – 1</b>
STANDARD PERFORMANCE CURVE .....	PAGE E – 1
PARTS LISTS:	
Pump Model .....	PAGE E – 3
Pump End Assembly .....	PAGE E – 7
Repair Rotating Assembly .....	PAGE E – 9
Air Compressor Assembly .....	PAGE E – 11
Coupling Kit .....	PAGE E – 12
PUMP AND SEAL DISASSEMBLY AND REASSEMBLY .....	PAGE E – 14
Priming Valve Removal And Disassembly .....	PAGE E – 14
Discharge Check Valve Removal and Disassembly .....	PAGE E – 15
Separating Pump And Coupling Kit From Engine .....	PAGE E – 15
Draining Oil From Seal Cavity .....	PAGE E – 15
Loosening Impeller .....	PAGE E – 15
Pump Casing And Wear Plate Removal .....	PAGE E – 16
Impeller Removal .....	PAGE E – 16
Seal Removal .....	PAGE E – 16
Shaft and Bearing Removal and Disassembly .....	PAGE E – 16
Shaft and Bearing Reassembly and Installation .....	PAGE E – 17
Securing Intermediate And Coupling Kit To Engine .....	PAGE E – 18
Seal Reassembly and Installation .....	PAGE E – 19
Impeller Installation And Adjustment .....	PAGE E – 20
Pump Casing And Wear Plate Installation .....	PAGE E – 21
Discharge Check Valve Reassembly And Installation .....	PAGE E – 21
Priming Valve Assembly And Installation .....	PAGE E – 21
LUBRICATION .....	PAGE E – 22
Seal Assembly .....	PAGE E – 22
Bearings .....	PAGE E – 22
Engine .....	PAGE E – 22

## INTRODUCTION

**Thank You** for purchasing a Gorman-Rupp pump. **Read this manual** carefully to learn how to safely install and operate your pump. Failure to do so could result in personal injury or damage to the pump.

Because pump installations are seldom identical, this manual cannot possibly provide detailed instructions and precautions for every aspect of each specific application. Therefore, it is the responsibility of the owner/installer of the pump to ensure that applications not addressed in this manual are performed **only** after establishing that neither operator safety nor pump integrity are compromised by the installation. Pumps and related equipment **must** be installed and operated according to all national, local and industry standards.

If there are any questions regarding the pump or its application which are not covered in this manual or in other literature accompanying this unit, please contact your Gorman-Rupp distributor, or The Gorman-Rupp Company:

**The Gorman-Rupp Company**  
**P.O. Box 1217**  
**Mansfield, Ohio 44901-1217**  
**Phone: (419) 755-1011**  
 or:  
**Gorman-Rupp of Canada Limited**  
**70 Burwell Road**  
**St. Thomas, Ontario N5P 3R7**  
**Phone: (519) 631-2870**

For information or technical assistance on the power source, contact the power source manufacturer's local dealer or representative.

## HAZARD AND INSTRUCTION DEFINITIONS

The following are used to alert maintenance personnel to procedures which require special attention, to those which could damage equipment, and to those which could be dangerous to personnel:



**Immediate hazards which WILL result in severe personal injury or death. These instructions describe the procedure required and the injury which will result from failure to follow the procedure.**



**Hazards or unsafe practices which COULD result in severe personal injury or death. These instructions describe the procedure required and the injury which could result from failure to follow the procedure.**



Hazards or unsafe practices which COULD result in minor personal injury or product or property damage. These instructions describe the requirements and the possible damage which could result from failure to follow the procedure.

### NOTE

*Instructions to aid in installation, operation, and maintenance or which clarify a procedure.*

## SAFETY - SECTION A

This information applies to Prime Aire® Series pumps. Refer to the manual accompanying the engine before attempting to begin operation.

Because pump installations are seldom identical, this manual cannot possibly provide detailed instructions and precautions for each specific application. Therefore, it is the owner/installer's responsibility to ensure that applications not addressed in this manual are performed only after establishing that neither operator safety nor pump integrity are compromised by the installation.



Before attempting to open or service the pump:

1. Familiarize yourself with this manual.
2. Shut down the engine and disconnect the positive battery cable to ensure that the pump will remain inoperative.
3. Allow the pump to completely cool if overheated.
4. Check the temperature and make sure the pump is cool before opening any covers, plates, or plugs.
5. Close the suction and discharge valves.
6. Vent the pump slowly and cautiously.
7. Drain the pump.



This pump is equipped with an automatic starting system, and is subject to automatic restart. Keep hands and clothing away from the unit to prevent injury during automatic operation. Disconnect the positive battery cable before per-

forming any maintenance. Failure to do so may result in serious personal injury.



Do not attempt to disengage any part of an overheated pump unit. Vapor pressure within the pump casing can eject these parts with great force when they are disengaged. Allow the pump to completely cool before servicing it.



This pump is designed to handle most non-volatile, non-flammable liquids containing specified entrained solids. Do not attempt to pump volatile, corrosive, or flammable liquids which may damage the pump or endanger personnel as a result of pump failure.



Death or serious personal injury and damage to the pump or components can occur if proper lifting procedures are not observed. Make certain that hoists, chains, slings or cables are in good working condition and of sufficient capacity and that they are positioned so that loads will be balanced and the pump or components will not be damaged when lifting. Suction and discharge hoses and piping must be removed from the pump before lifting. Lift the pump or component only as high as necessary and keep personnel away from suspended objects.

**WARNING!**

After the pump has been installed, make certain that the pump and all piping or hose connections are tight, properly supported and secure before operation.

**WARNING!**

Do not operate the pump against a closed discharge valve. If operated against a closed discharge valve, pump components will deteriorate, and the liquid could come to a boil, build pressure, and cause the pump casing to rupture or explode. Momentary closure of a discharge valve is acceptable only when required for startup or shutdown procedures.

**WARNING!**

Do not remove plates, covers, gauges, pipe plugs, or fittings from an overheated pump. Vapor pressure within the pump can cause parts being disengaged to be ejected with great force. Allow the pump to cool completely before servicing.

**WARNING!**

This pump may be used to handle materials which could cause illness through direct exposure or emitted fumes. Wear adequate protective clothing when working on the pump or piping.

**WARNING!**

Do not operate the pump without guards in place over the rotating parts. Exposed rotating parts can catch clothing, fingers or tools, causing severe injury to personnel.

**CAUTION**

Make sure the pump is level. Lower jack stands and chock the wheels, if so equipped. Use caution when positioning the skid-mounted unit to prevent damage to the fuel tank.

**DANGER!**

Do not operate an internal combustion engine in an explosive atmosphere. When operating an internal combustion engine in an enclosed area, make sure exhaust fumes are piped to the outside. These fumes contain carbon monoxide, a deadly gas that is colorless, tasteless and odorless.

**WARNING!**

Fuel used by internal combustion engines presents an extreme explosion and fire hazard. Make certain that all fuel lines are securely connected and free of leaks. Never refuel a hot or running engine. Avoid overfilling the fuel tank. Always use the correct type of fuel.

## INSTALLATION – SECTION B

**Review all SAFETY information in Section A.**

Since pump installations are seldom identical, this section offers only general recommendations and practices required to inspect, position, and arrange the pump and piping.

Most of the information pertains to a standard **static lift** application where the pump is positioned above the free level of liquid to be pumped.

If installed in a **flooded suction application** where the liquid is supplied to the pump under pressure, some of the information such as mounting, line configuration, and priming must be tailored to the

specific application. Since the pressure supplied to the pump is critical to performance and safety, **be sure** to limit the incoming pressure to 50% of the maximum permissible operating pressure as shown on the pump performance curve.

For further assistance, contact your Gorman-Rupp distributor or the Gorman-Rupp Company.

**Pump Dimensions**

See Figure 1 for the approximate physical dimensions of this pump.

### OUTLINE DRAWING

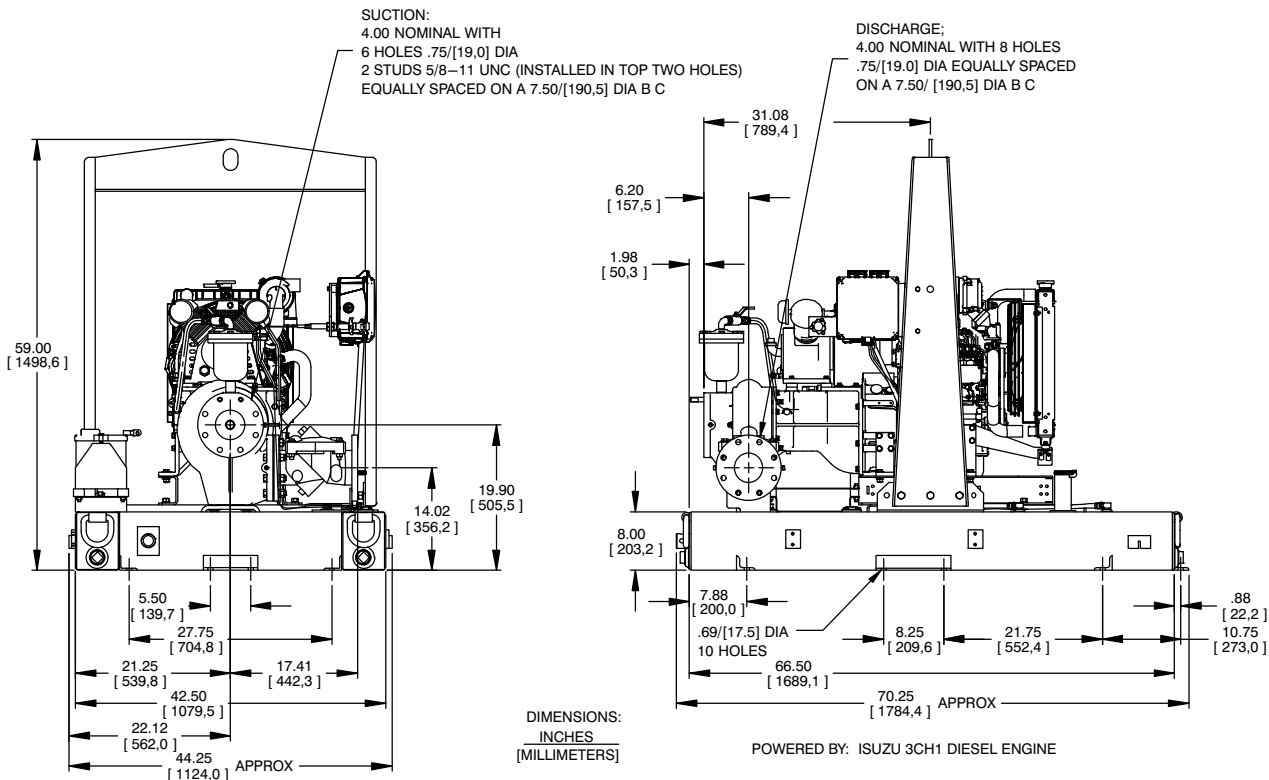

**Figure 1. Pump Model VPA4A60C-3CH1 FT4**



## PREINSTALLATION INSPECTION

The pump assembly was inspected and tested before shipment from the factory. Before installation, inspect the pump for damage which may have occurred during shipment. Check as follows:

- a. Inspect the pump assembly for cracks, dents, damaged threads, and other obvious damage.
- b. Check for and tighten loose attaching hardware. Since gaskets tend to shrink after drying, check for loose hardware at mating surfaces.
- c. Carefully read all tags, decals, and markings on the pump assembly, and perform all duties indicated.
- d. Check levels and lubricate as necessary. Refer to **LUBRICATION** in the **MAINTENANCE AND REPAIR** section of this manual and perform duties as instructed.
- e. If the pump and engine have been stored for more than 12 months, some of the components or lubricants may have exceeded their maximum shelf life. These **must be inspected or replaced** to ensure maximum pump service.

If the maximum shelf life has been exceeded, or if anything appears to be abnormal, contact your Gorman-Rupp distributor or the factory to determine the repair or updating policy. **Do not** put the pump into service until appropriate action has been taken.

### Battery Specifications And Installation

Unless otherwise specified on the pump order, the engine battery was **not** included with the unit. When selecting a battery, refer to the specifications on the paper tag attached to the battery box in order to ensure the proper size and electrical characteristics of the battery.

Refer to the information accompanying the battery and/or electrolyte solution for activation and charging instructions.

Before installing the battery, clean the positive and negative cable connectors, and the battery terminals. Secure the battery by tightening the holddown brackets. The terminals and clamps may be coated with petroleum jelly to retard corrosion. Connect and tighten the positive cable first, then the negative cable.

## POSITIONING PUMP

### Lifting



**Death or serious personal injury and damage to the pump or components can occur if proper lifting procedures are not observed. Make certain that hoists, chains, slings or cables are in good working condition and of sufficient capacity and that they are positioned so that loads will be balanced and the pump or components will not be damaged when lifting. Suction and discharge hoses and piping must be removed from the pump before lifting. Lift the pump or component only as high as necessary and keep personnel away from suspended objects.**

Pump unit weights will vary depending on the mounting and drive provided. Check the shipping tag on the unit packaging for the actual weight, and use lifting equipment with appropriate capacity. Drain the pump and remove all customer-installed equipment such as suction and discharge hoses or piping before attempting to lift existing, installed units.

### Mounting

Locate the pump in an accessible place as close as practical to the liquid being pumped. Level mounting is essential for proper operation.

The pump may have to be supported or shimmed to provide for level operation or to eliminate vibration.

If the pump has been mounted on a moveable base, make certain the base is stationary by setting

the brake and blocking the wheels before attempting to operate the pump.

To ensure sufficient lubrication and fuel supply to the engine, **do not** position the pump and engine more than 15° off horizontal for continuous operation. The pump and engine may be positioned up to 30° off horizontal for **intermittent operation only**; however, the engine manufacturer should be consulted for continuous operation at angles greater than 15°.

## SUCTION AND DISCHARGE PIPING

Pump performance is adversely effected by increased suction lift, discharge elevation, and friction losses. See the performance curve and notes on Page E-1 to be sure your overall application allows pump to operate within the safe operation range.

### Materials

Either pipe or hose may be used for suction and discharge lines; however, the materials must be compatible with the liquid being pumped. If hose is used in suction lines, it must be the rigid-wall, reinforced type to prevent collapse under suction. Using piping couplings in suction lines is not recommended.

### Line Configuration

Keep suction and discharge lines as straight as possible to minimize friction losses. Make minimum use of elbows and fittings, which substantially increase friction loss. If elbows are necessary, use the long-radius type to minimize friction loss.

### Connections to Pump

Before tightening a connecting flange, align it exactly with the pump port. Never pull a pipe line into place by tightening the flange bolts and/or couplings.

Lines near the pump must be independently supported to avoid strain on the pump which could cause excessive vibration, decreased bearing life, and increased shaft and seal wear. If hose-type lines are used, they should have adequate support

to secure them when filled with liquid and under pressure.

### Gauges

Most pumps are drilled and tapped for installing discharge pressure and vacuum suction gauges. If these gauges are desired for pumps that are not tapped, drill and tap the suction and discharge lines not less than 18 inches (457,2 mm) from the suction and discharge ports and install the lines. Installation closer to the pump may result in erratic readings.

## SUCTION LINES

To avoid air pockets which could affect pump priming, the suction line must be as short and direct as possible. When operation involves a suction lift, the line must always slope upward to the pump from the source of the liquid being pumped; if the line slopes down to the pump at any point along the suction run, air pockets will be created.

### Fittings

Suction lines should be the same size as the pump inlet. If reducers are used in suction lines, they should be the eccentric type, and should be installed with the flat part of the reducers uppermost to avoid creating air pockets. Valves are not normally used in suction lines, but if a valve is used, install it with the stem horizontal to avoid air pockets.

### Strainers

If a strainer is furnished with the pump, be certain to use it; any spherical solids which pass through a strainer furnished with the pump will also pass through the pump itself.

If a strainer is not furnished with the pump, but is installed by the pump user, make certain that the total area of the openings in the strainer is at least three or four times the cross section of the suction line, and that the openings will not permit passage of solids larger than the solids handling capability of the pump.

This pump is designed to handle up to 3-inch (76,2 mm) diameter spherical solids.

**Sealing**

Since even a slight leak will affect priming, head, and capacity, especially when operating with a high suction lift, all connections in the suction line should be sealed with pipe dope to ensure an airtight seal. Follow the sealant manufacturer's recommendations when selecting and applying the pipe dope. The pipe dope should be compatible with the liquid being pumped.

**Suction Lines In Sumps**

If a single suction line is installed in a sump, it should be positioned away from the wall of the sump at a distance equal to 1 1/2 times the diameter of the suction line.

If there is a liquid flow from an open pipe into the sump, the flow should be kept away from the suction inlet because the inflow will carry air down into the sump, and air entering the suction line will reduce pump efficiency.

If it is necessary to position inflow close to the suction inlet, install a baffle between the inflow and the suction inlet at a distance 1-1/2 times the diameter

of the suction pipe. The baffle will allow entrained air to escape from the liquid before it is drawn into the suction inlet.

If two suction lines are installed in a single sump, the flow paths may interact, reducing the efficiency of one or both pumps. To avoid this, position the suction inlets so that they are separated by a distance equal to at least 3 times the diameter of the suction pipe.

**Suction Line Positioning**

The depth of submergence of the suction line is critical to efficient pump operation. Figure 2 shows recommended minimum submergence vs. velocity.

**NOTE**

*The pipe submergence required may be reduced by installing a standard pipe increaser fitting at the end of the suction line. The larger opening size will reduce the inlet velocity. Calculate the required submergence using the following formula based on the increased opening size (area or diameter).*

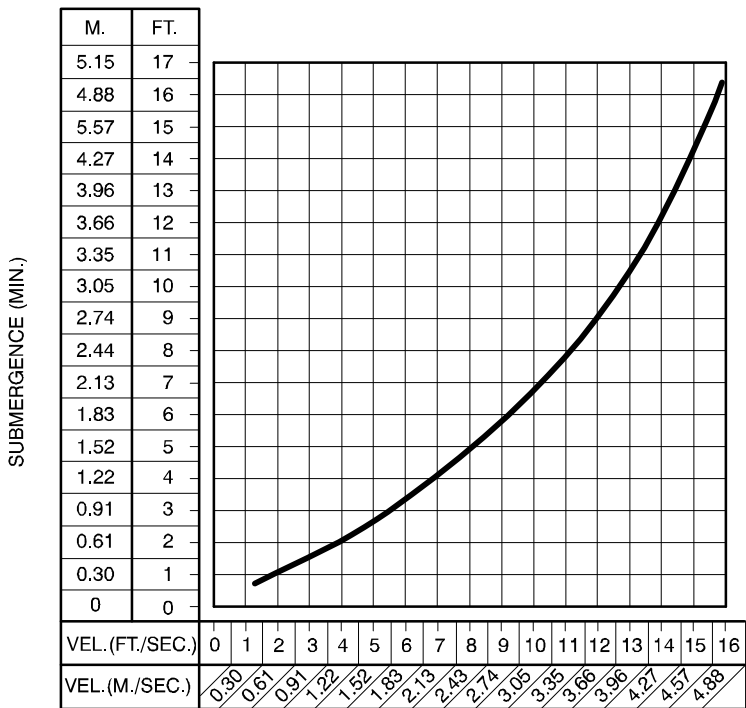

VELOCITY (FT./SEC.) =  $\frac{\text{FLOW (G.P.M.)} \times .321}{\text{AREA IN IN.}^2}$  OR  $\frac{\text{FLOW (G.P.M.)} \times .4085}{(\text{DIAMETER IN IN.})^2}$

VELOCITY (M./SEC.) =  $\frac{\text{FLOW (L/SEC.)} \times .001}{\text{AREA IN M}^2}$  OR  $\frac{\text{FLOW (M}^3/\text{HR} \times 353.7}{(\text{DIAMETER IN MM})^2}$

**Figure 2. Recommended Minimum Suction Line Submergence vs. Velocity**

## DISCHARGE LINES

### Siphoning

Do not terminate the discharge line at a level lower than that of the liquid being pumped unless a siphon breaker is used in the line. Otherwise, a siphoning action causing damage to the pump could result.

### Valves

This pump is designed with a check valve in the discharge line.

If a throttling valve is desired in the discharge line, use a valve as large as the largest pipe to minimize friction losses. Never install a throttling valve in a suction line.

With high discharge heads, it is recommended that a throttling valve be installed in the discharge line to protect the pump from excessive shock pressure and reverse rotation when it is stopped.

## ALIGNMENT

The alignment of the pump and the engine is critical for trouble-free mechanical operation. See Section E, **Securing Intermediate And Drive Assembly To Engine** for detailed information.

## AUTO-START

The standard pump is equipped with an auto-start control system which allows the pump to start and stop as the liquid level in the wet well or sump rises and falls.

Refer to the information which follows for installation details for the liquid level sensing system provided with your pump.

## Float Switch Installation

The Float Switch autostart system employs either a single or double float switch, where a bulb raises or lowers (floats) with the liquid level, thus activating an enclosed miniature switch. The floats are equipped with a socket type connector that plugs into a matching receptacle on the auto-start control box.

Standard floats are equipped with 50 feet (15,2 m) of cable.

When installing the floats, note the following:

- a. **Be sure** to provide sufficient room in the wet well or sump so that floats do not get obstructed or drawn into the suction line. If a flexible suction hose is used, it may be extended to lay along the bottom of the wet well or sump and the float can be attached to the hose above the point where it bends along the bottom. Direct the suction line toward the flow, and the float(s) away from the flow. If a standpipe is available, attach the float switch cable to the standpipe in the sump at the approximate desired liquid level.
- b. In a single float system, the cable can be tethered to the suction line or standpipe approximately 6 inches (152 mm) above the float. This setting allows approximately 9 inches (229 mm) of liquid rise between pump start/stop. The start/stop interval may be increased by extending the float end of the cable. The liquid level in the sump will increase approximately 8 inches (203 mm) between start/stop intervals for every 6 inches (152 mm) of cable increase.
- c. If a double float switch system is used, position the "Start" float at the desired high water level in the sump, and the "Stop" float at the desired low water level in the pump.
- d. Refer to Figure 3 for additional float switch data.

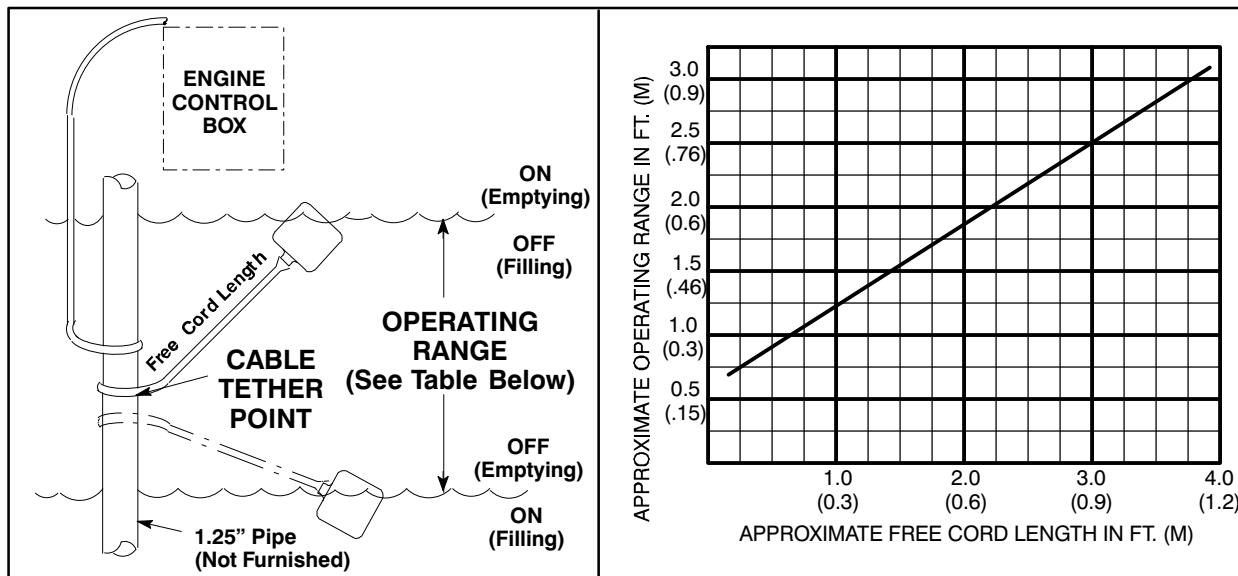

Figure 3. Float Switch Data

**COLD WEATHER INSTALLATION**

If the pump is to be installed in an environment where sub-freezing temperatures will occur during operation, consideration must be given to prevent the pump and components from freezing when the pump is idle between pumping cycles. With Gorman-Rupp priming assisted pumps, there are two methods of accomplishing this.

One method is through the use of an optional heated priming chamber, which is available as a factory-installed option or as a retrofit kit for most models (consult the factory). This method pumps heated liquid from the engine cooling system through the priming chamber to heat the chamber and its contents. This method is particularly effective where pumping cycles are short enough to ensure that the liquid in the priming chamber never fully freezes.

The second method involves configuring the pumping system to drain both the priming chamber and pump casing after each pumping cycle. With no liquid remaining in the system, freezing cannot occur.

To configure the pump to drain between pumping cycles, the first step is to remove the check valve

from the line that runs between the top of the priming hopper and the priming venturi. This check valve is located close to the venturi end of the line. Remove the check valve, then reconnect the line directly to the venturi. This will allow air to enter the pump through the top of the priming hopper when the pump shuts off, providing for complete drainage of the pump and priming hopper.

Next, install a drain line between the pump drain and the wet well or sump. This line must remain submerged in the liquid below the pump down level of the liquid level control device; otherwise, the pump may not prime. If the application involves liquids that could clog the drain line, make sure to check the line periodically to ensure it remains open; otherwise, liquid could remain in the casing, resulting in freezing and potential damage to the pumping system.

Configuring the system to drain between cycles will help ensure that the pump will not freeze during cold weather applications. **However, it should be noted that the time required for the pump to begin to discharge liquid will increase, as the pump will have to fully re-prime at the beginning of each pumping cycle.**

## OPERATION – SECTION C

Review all **SAFETY** information in Section A.

Follow the instructions on all tags, labels and decals attached to the pump.



**Do not operate an internal combustion engine in an explosive atmosphere. When operating an internal combustion engine in an enclosed area, make sure exhaust fumes are piped to the outside. These fumes contain carbon monoxide, a deadly gas that is colorless, tasteless and odorless.**

### OPERATION



**This pump is designed to handle most non-volatile, non-flammable liquids containing specified entrained solids and corrosives. Do not attempt to pump volatile, corrosive, or flammable liquids which may damage the pump or endanger personnel as a result of pump failure.**



Pump speed and operating condition points must be within the continuous performance range shown on the performance curve in Section E on page E-1.

### PRIMING

Install the pump and piping as described in **INSTALLATION**. Make sure that the piping connections are tight, and that the pump is securely mounted. Check that the pump is properly lubri-

cated (see **LUBRICATION** in **MAINTENANCE AND REPAIR**).

The pump will begin to prime upon startup. The air in the suction line will be discharged from the educator discharge line. Complete priming is indicated by a positive discharge pressure reading.

If full priming is not achieved, the discharge check valve may be malfunctioning. If this occurs, shut down the pump and consult **Maintenance and Repair**, Section E for further details.

### STARTING

Check the fuel level and oil levels in the engine, air compressor, pump bearings and seal housing.

Make sure the pump is level. Lower the jack stands and chock the wheels, if so equipped.

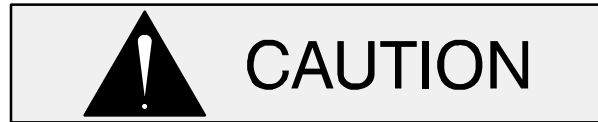

Make sure the pump is level. Lower jack stands and chock the wheels, if so equipped. Use caution when positioning the skid-mounted unit to prevent damage to the fuel tank.



**This pump is equipped with an automatic starting system, and is subject to automatic restart. Keep hands and clothing away from the unit to prevent injury during automatic operation. Disconnect the positive battery cable before performing any maintenance. Failure to do so may result in serious personal injury.**

Consult the engine operations manual before attempting to start the unit.

### Manual Starting

On initial start-up, set the engine speed at in the half-throttle position. Turn the keyswitch to 'MANU-

AL'. After the engine starts and the unit is fully primed, adjust the engine RPM until the desired flow rate is achieved.



Pump speed and operating condition points must be within the continuous performance range shown on the curve on Page E-1.

### Automatic Starting

With the float system installed, follow the procedures outlined for manual starting and throttle adjustment. Switch the keyswitch to 'OFF' until the water level rises above the on point for the float system, then turn the keyswitch to the 'AUTO' setting. The unit will run until the float signals the control that the water in the wet well is at the float off point, at which time the unit will shut down automatically. When the float signals the control that the water in the wet well is at the float on point, the unit will restart automatically, repeating the cycle.

### Priming

The pump will begin to prime upon startup. The air in the suction line will be discharged from the educator discharge line. Complete priming is indicated by a positive discharge pressure reading.

If full priming is not achieved, the discharge check valve may be malfunctioning. If this occurs, shut down the pump and consult the separate **Maintenance and Repair** manual for further details.

### Routine Operation



**Do not operate an internal combustion engine in an explosive atmosphere. When operating an internal combustion engine in an enclosed area, make sure exhaust fumes are piped to the outside.**

**These fumes contain carbon monoxide, a deadly gas that is colorless, tasteless and odorless.**

Adjust the engine speed to achieve the desired output. Do not exceed the factory set engine speed and system operating pressure. Do not operate below the recommended operating speed (if applicable).



**Never tamper with the governor to gain more power. The governor establishes safe operating limits that should not be exceeded. Refer to the Performance Curve in the separate Parts List Manual for the maximum continuous operating speed for this pump.**

### Operation In Extreme Heat

The safety shutdown system will automatically stop the unit if engine operating temperature exceeds design limits. If engine over-temperature shutdown occurs, allow the unit to cool before restarting.

If engine overheating continues, check the engine lubricant level and viscosity. Consult the engine operation manual for the recommended lubricant for operation in extreme heat.

If the unit is being operated in the **automatic** mode, adjust the float(s) to allow shorter run and longer cooling periods, if possible.



**This pump is equipped with automatic liquid level controls, and is subject to automatic restart. Keep hands and clothing away from the unit to prevent injury during automatic operation. Disconnect the battery before performing any maintenance. Failure to do so may result in serious personal injury.**

## OPERATIONAL CHECKS

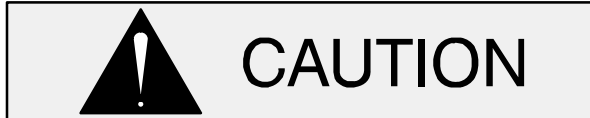

The engine powering this unit may be equipped with an EPA-compliant Exhaust After-Treatment (EAT) system, which is designed to reduce the amount of pollutants expelled into the atmosphere during operation. Refer to the manual accompanying the engine for a detailed explanation of the engine EAT and follow all instructions in the engine manual to ensure uninterrupted operation of the unit.

### Leakage

Once the pump is fully primed, no leakage should be visible at pump mating surfaces, or at pump connections or fittings. Keep all line connections and fittings tight to maintain maximum pump efficiency.

### Pump Vacuum Check

Read the vacuum gauge with the pump primed and at operation speed. Shut off the pump. The vacuum gauge reading will immediately drop proportionate to static suction lift, and should then stabilize. If the vacuum reading falls off rapidly after stabilization, an air leak exists. Before checking for the source of the leak, check the point of installation of the vacuum gauge.

### Liquid Temperature And Overheating

The **maximum** liquid temperature for this pump is 160° F (71°C). Do not apply it at a higher operating temperature.

Overheating can occur if operated with the valves in the suction or discharge lines closed. Operating against closed valves could bring the liquid to a boil, build pressure, and cause the pump to rupture or explode. If overheating occurs, stop the pump immediately and allow it to completely cool before servicing it. **Approach any over-heated pump cautiously.**



**Allow an over-heated pump to completely cool before servicing. Do not remove plates, covers, gauges, or fittings from an overheated pump. Liquid within the pump can reach boiling temperatures, and vapor pressure within the pump can cause parts being disengaged to be ejected with great force. After the pump cools, drain the liquid from the pump by removing the casing drain plug. Use caution when removing the plug to prevent injury to personnel from hot liquid.**

### Strainer Check

Check the strainer regularly, and clean it as necessary. The strainer should also be checked if pump flow rate begins to drop. Monitor and record the vacuum suction gauge readings regularly to detect strainer blockage.

**Never** introduce air or steam pressure into the pump casing or piping to remove a blockage. This could result in personal injury or damage to the equipment. If backflushing is absolutely necessary, **liquid pressure** must be limited to 50% of the maximum permissible operating pressure shown on the pump performance curve.

## STOPPING

### Manual Stopping

Never halt the flow of liquid suddenly. If the liquid being pumped is stopped abruptly, damaging shock waves can be transmitted to the pump and piping system. Close all connecting valves slowly.

Reduce the throttle speed slowly and allow the engine to idle briefly before stopping.

In the manual mode, reduce the throttle speed slowly, and allow the engine to idle briefly before switching the HAND-OFF-AUTO switch to 'OFF'.





If the application involves a high discharge head, gradually close the discharge throttling valve before stopping the pump.

After stopping the pump, switch off the engine ignition and remove the key to ensure that the pump will remain inoperative.

### Automatic Stopping

In the automatic mode, the pump will stop when the liquid in the wet well or sump lowers and activates the "Off" float switch(s). The pump will restart automatically when the liquid rises and activates the "On" float switch(s).

### Safety Shutdown System

The unit is equipped with a safety system to automatically shut down the engine under certain conditions. The engine will automatically shut down:

1. If the engine exceeds its safe operating temperature.
2. If the engine oil pressure drops below design limits.
3. If the engine fails to start within a pre-set period of time.
4. If the engine speed exceeds the safe operating range.
5. If the engine fan belt breaks.

Lights on the control panel will indicate which of the safety features has caused the engine to shut down.

Should any of the safety features cause the engine to shut down, **the cause must be determined and corrected** before putting the unit back into service. The engine **will not restart** until the key switch has been returned to the 'OFF' position for at least 10 seconds.

All safety shutdown features are pre-set at the factory for optimum performance and safety; **do not** attempt to adjust these settings.



**Never disconnect any of the safety shutdown features; this will void the warranty and could result in serious damage to the unit and/or injury to personnel. Safety shutdown features are pre-set at the factory; do not attempt to adjust any of the settings. Determine the cause of shutdown before putting the unit back into service. Consult the factory for additional information.**

### PERIODIC CHECKS

#### Seal Cavity And Bearing Lubrication

Both the seal and bearing cavities were fully lubricated at the factory. Check the lubrication levels before startup, and regularly thereafter as indicated in Section E, **Maintenance and Repair**. When lubrication is required, use **only** SAE No. 30 non-detergent oil.

#### Bearing Temperature Check

Bearings normally run at higher than ambient temperatures because of heat generated by friction. Temperatures up to 160°F (71°C) are considered normal for bearings, and they can operate safely to at least 180°F (82°C).

Checking bearing temperatures by hand is inaccurate. Bearing temperatures can be measured accurately by placing a contact-type thermometer against the housing. Record this temperature for future reference.

A sudden increase in bearing temperatures is a warning that the bearings are at the point of failing to operate properly. Make certain that the bearing lubricant is of the proper viscosity and at the correct level (see **LUBRICATION** in Section E, **Maintenance and Repair**). Bearing overheating can also be caused by shaft misalignment and/or excessive vibration.

When pumps are first started, the bearings may seem to run at temperatures above normal. Continued operation should bring the temperatures down to normal levels.

### Air Compressor

The air compressor was lubricated for test at the factory. However, **always** check the lubrication level before startup.

Consult the manual accompanying the air compressor and perform all duties and checks as indicated.

### Additional Checks

See Page D—4 and perform all recommended preventive maintenance checks applicable to your particular unit.

Consult the manual accompanying the engine and perform any and all routine checks recommended by the engine manufacturer.

### COLD WEATHER PRESERVATION

If the pump will be idle for an extended period of time in below freezing conditions, drain the pump

and priming hopper to prevent damage from freezing. Also, clean out any solids by flushing with a hose. Operate the pump for approximately one minute; this will remove any remaining liquid that could freeze the pump rotating parts. If the pump will be idle for more than a few hours, or if it has been pumping liquids containing a large amount of solids, drain the pump, and flush it thoroughly with clean water. To prevent large solids from clogging the drain port and preventing the pump from completely draining, insert a rod or stiff wire in the drain port, and agitate the liquid during the draining process. Clean out any remaining solids by flushing with a hose.

If the pump is to be installed in an environment where sub-freezing temperatures will occur during operation, consideration must be given to prevent the pump and components from freezing when the pump is idle between pumping cycles. Refer to **COLD WEATHER INSTALLATION** in the **Installation** section of this manual for details.

## TROUBLESHOOTING – SECTION D

Review all SAFETY information in Section A.



Before attempting to open or service the pump:

1. Familiarize yourself with this manual.
2. Turn the keyswitch to 'OFF', and disconnect the positive battery cable to ensure that the pump will remain inoperative.
3. Allow the pump to completely cool if overheated.
4. Check the temperature before opening any covers, plates, or plugs.

5. Close the suction and discharge valves.
6. Vent the pump slowly and cautiously.
7. Drain the pump.



This pump is equipped with an automatic starting system, and is subject to automatic restart. Keep hands and clothing away from the unit to prevent injury during automatic operation. Disconnect the positive battery cable before performing any maintenance. Failure to do so may result in serious personal injury.

TROUBLE	POSSIBLE CAUSE	PROBABLE REMEDY
PUMP FAILS TO PRIME	Discharge check valve contaminated, damaged, or unable to seat. Air leak in suction line. Lining of suction hose collapsed. Leaking or worn seal or pump gasket.  Suction lift or discharge head too high.  Air compressor damaged or belts broken. Strainer clogged.	Clean or replace check valve.  Correct leak. Replace suction hose. Check pump vacuum. Replace leaking or worn seal or gasket. Check piping installation and install bypass line if needed. See <b>INSTALLATION</b> . Check and repair/replace.  Check strainer and clean if necessary.
PUMP STOPS OR FAILS TO DELIVER RATED FLOW OR PRESSURE	Eductor clogged. Air leak in suction line. Lining of suction hose collapsed. Leaking or worn seal or pump gasket.	Check and clean eductor. Correct leak. Replace suction hose. Check pump vacuum. Replace leaking or worn seal or gasket.

TROUBLE	POSSIBLE CAUSE	PROBABLE REMEDY
PUMP STOPS OR FAILS TO DELIVER RATED FLOW OR PRESSURE (cont.)	<p>Strainer clogged.</p> <p>Discharge check valve clogged.</p> <p>Suction intake not submerged at proper level or sump too small.</p> <p>Impeller or other wearing parts worn or damaged.</p> <p>Impeller clogged.</p> <p>Discharge head too high.</p> <p>Suction lift too high.</p> <p>Pump speed too slow.</p> <p>Belt or flexible coupling broken.</p>	<p>Check strainer and clean if necessary.</p> <p>Check and clean check valve.</p> <p>Check installation and correct submergence as needed.</p> <p>Replace worn or damaged parts. Check that impeller is properly centered and rotates freely.</p> <p>Free impeller of debris.</p> <p>Install bypass line.</p> <p>Measure lift w/vacuum gauge. Reduce lift and/or friction losses in suction line.</p> <p>Check engine output; consult engine operation manual.</p> <p>Check and replace as necessary.</p>
PUMP REQUIRES TOO MUCH POWER	<p>Pump speed too high.</p> <p>Extreme ambient temperature.</p> <p>Discharge head too low.</p> <p>Fuel filter clogged.</p> <p>Liquid solution too thick.</p> <p>Fuel contaminated.</p> <p>Pump or jack shaft bearing(s) frozen.</p>	<p>Check engine output.</p> <p>Reduce pump output.</p> <p>Adjust discharge valve.</p> <p>Check &amp; replace often in extreme operating conditions.</p> <p>Dilute if possible.</p> <p>Check and replace as required.</p> <p>Disassemble, check and replace bearing(s) as required..</p>
PUMP CLOGS FREQUENTLY	<p>Discharge flow too slow.</p> <p>Suction check valve or foot valve clogged or binding.</p> <p>Liquid solution too thick.</p>	<p>Open discharge valve fully to increase flow rate, and run engine at maximum governed speed.</p> <p>Clean valve.</p> <p>Dilute if possible.</p>
EXCESSIVE NOISE	<p>Cavitation in pump.</p> <p>Pumping entrained air.</p> <p>Pump or drive not securely mounted.</p> <p>Impeller clogged or damaged.</p>	<p>Reduce suction lift and/or friction losses in suction line. Record vacuum and pressure gauge readings and consult local representative or factory.</p> <p>Locate and eliminate source of air bubble.</p> <p>Secure mounting hardware.</p> <p>Clean out debris; replace damaged parts.</p>

TROUBLE	POSSIBLE CAUSE	PROBABLE REMEDY
BEARINGS RUN TOO HOT	Bearing temperature is high, but within limits.  Low or incorrect lubricant.  Suction and discharge lines not properly supported.  Drive misaligned.  Excessive tension on drive belt.	Check bearing temperature regularly to monitor any increase.  Check for proper type and level of lubricant.  Check piping installation for proper support.  Align drive properly.  Check belt tension. Adjust as required.

## PREVENTIVE MAINTENANCE

Since pump applications are seldom identical, and pump wear is directly affected by such things as the abrasive qualities, pressure and temperature of the liquid being pumped, this section is intended only to provide general recommendations and practices for preventive maintenance. Regardless of the application however, following a routine preventive maintenance schedule will help assure trouble-free performance and long life from your Gorman-Rupp pump. For specific questions concerning your application, contact your Gorman-Rupp distributor or the Gorman-Rupp Company.

Record keeping is an essential component of a good preventive maintenance program. Changes in suction and discharge gauge readings (if so

equipped) between regularly scheduled inspections can indicate problems that can be corrected before system damage or catastrophic failure occurs. The appearance of wearing parts should also be documented at each inspection for comparison as well. Also, if records indicate that a certain part (such as the seal) fails at approximately the same duty cycle, the part can be checked and replaced before failure occurs, reducing unscheduled down time.

For new applications, a first inspection of wearing parts at 250 hours will give insight into the wear rate for your particular application. Subsequent inspections should be performed at the intervals shown on the chart below. Critical applications should be inspected more frequently.

<b>Preventive Maintenance Schedule</b>					
<b>Item</b>	<b>Service Interval*</b>				
	<b>Daily</b>	<b>Weekly</b>	<b>Monthly</b>	<b>Semi-Annually</b>	<b>Annually</b>
General Condition (Temperature, Unusual Noises or Vibrations, Cracks, Leaks, Loose Hardware, Etc.)	I				
Pump Performance (Gauges, Speed, Flow)	I				
Bearing Lubrication		I			R
Seal Lubrication (And Packing Adjustment, If So Equipped)		I			R
V-Belts (If So Equipped)			I		
Air Release Valve Plunger Rod (If So Equipped)			I	C	
Front Impeller Clearance (Wear Plate)				I	
Rear Impeller Clearance (Seal Plate)				I	
Check Valve					I
Pressure Relief Valve (If So Equipped)					C
Pump and Driver Alignment					I
Shaft Deflection					I
Bearings					I
Bearing Housing					I
Piping					I
Driver Lubrication – See Mfgr’s Literature					I

Legend:  
 I = Inspect, Clean, Adjust, Repair or Replace as Necessary  
 C = Clean  
 R = Replace

\* Service interval based on an intermittent duty cycle equal to approximately 4000 hours annually. Adjust schedule as required for lower or higher duty cycles or extreme operating conditions.

## PUMP MAINTENANCE AND REPAIR - SECTION E

**MAINTENANCE AND REPAIR OF THE WEARING PARTS OF THE PUMP WILL MAINTAIN PEAK OPERATING PERFORMANCE.**

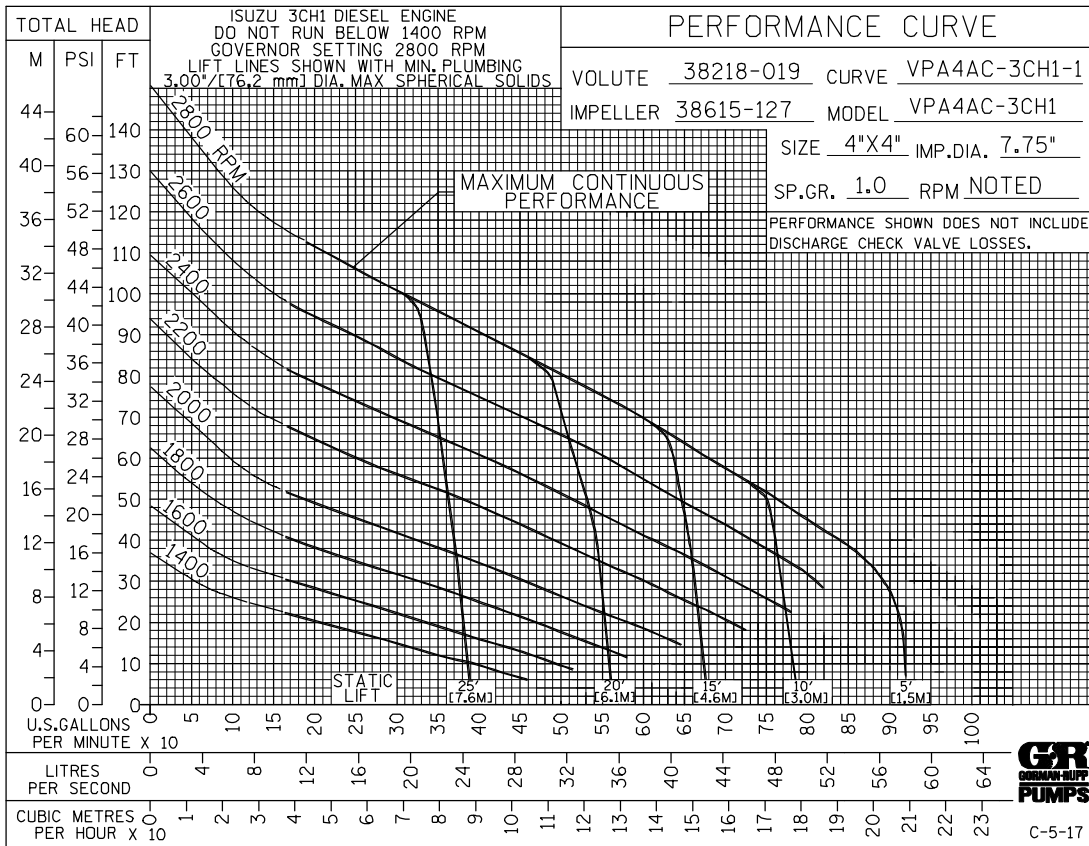

**\* STANDARD PERFORMANCE FOR PUMP MODEL VPA4A60C-3CH1 FT4**

\* Based on 70°F (21°C) clear water at sea level with minimum suction lift. Since pump installations are seldom identical, your performance may be different due to such factors as viscosity, specific gravity, elevation, temperature, and impeller trim.

Contact the Gorman-Rupp Company to verify performance or part numbers.



Pump speed and operating condition points must be within the continuous performance range shown on the curve.

If your pump serial number is followed by an "N", your pump is **NOT** a standard production model.

ILLUSTRATION

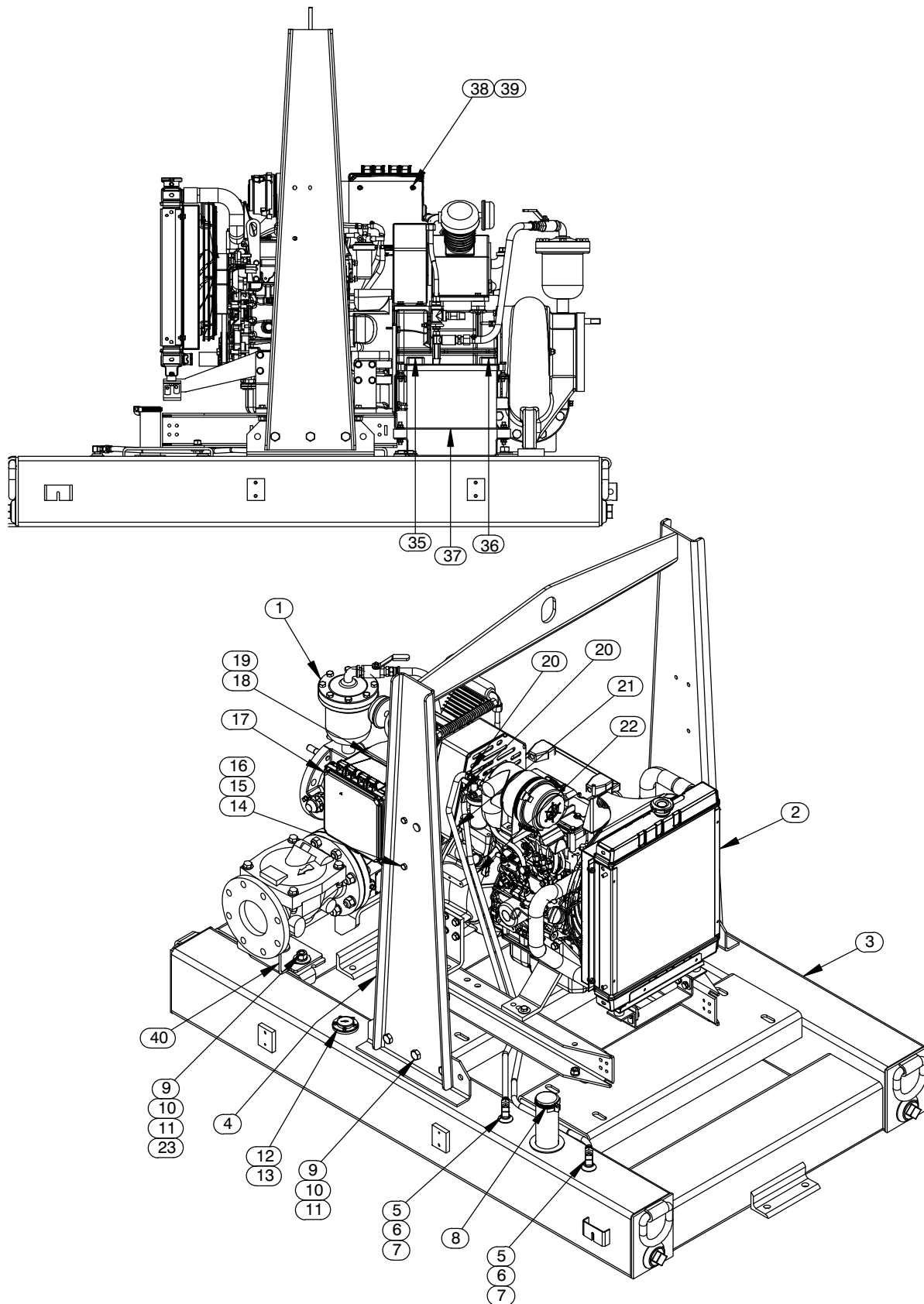

Figure 1. Pump Model VPA4A60C-3CH1 FT4



**PARTS LIST**  
**Pump Model VPA4A60C-3CH1 FT4**  
 (From S/N 1645513 Up)

If your pump serial number is followed by an "N", your pump is **NOT** a standard production model. Contact the Gorman-Rupp Company to verify part numbers.

ITEM NO.	PART NAME	PART NUMBER	QTY	ITEM NO.	PART NAME	PART NUMBER	QTY
1	PUMP END ASSEMBLY	46183-600	1	29	LOCK WASHER	21171-511	6
2	ISUZU ENGINE 3CH1 FT4	29223-431	1	30	HOSE BARB FITTING	26523-389	1
3	BASE/FUEL TANK ASSY	41553-060 24150	1	31	.37 ID X 30" LG HOSE	18513-302	1
4	LIFT BAIL ASSEMBLY	44715-062 24150	1	32	CABLE TIE	27111-218	1
5	FUEL PICKUP	29332-147	2	33	HOSE BARB FITTING	26523-447	1
6	CONNECTOR	S1447	2	34	AIR VENT	S1703	1
7	HOSE BARB FTG	26523-016	2	35	1/0 POS. CABLE ASSY	47311-108	1
8	LOCKING FUEL CAP	29332-111	1	36	1/0 NEG. CABLE ASSY	47311-159	1
9	HEX HEAD CAP SCREW	B1006 15991	10	37	BATTERY BOX, 34 FRAME	42432-015	1
10	LOCK WASHER	J10 15991	10	38	HEX NUT	D04 15991	4
11	HEX NUT	D10 15991	8	39	LOCKWASHER	J04 15991	4
12	MECH FUEL GAUGE	29332-172	1	40	SUPPORT BRACKET	34144-059 15080	1
13	SCKT HEAD CAP SCREW	BD#10-03S 15991	5	41	HOSE CLAMP	26518-642	1
14	HEX HEAD CAP SCREW	B0604 15991	2	NOT SHOWN:			
15	LOCK WASHER	J06 15991	2		ENGINE START-UP TAG	38816-269	1
16	HEX NUT	D06 15991	2		WARNING DECAL	2613FE	1
17	CNTRL PNL INSTALL KIT	48122-544	1		CAUTION DECAL	2613FJ	1
18	CNTRL PANEL BRACKET	34518-025 15080	1		G-R DECAL 6 IN	GR-06	2
19	STUD MOUNT	24631-014	4		FUEL DECAL	38816-196	1
20	HOSE CLAMP	26518-641	2		ENG OPERATION DECAL	38816-347	1
21	.31 ID X 48" LG HOSE	18513-053	1		INSTRUCTION DECAL	38818-144	1
22	.31 ID X 48" LG HOSE	18513-053	1		WARNING DECAL	38816-345	2
23	FLAT WASHER	K10 15991	6		WARNING DECAL	38817-101	2
24	HEX HEAD CAP SCREW	B0805 15991	4		WARNING DECAL	38816-203	4
25	FLAT WASHER	K08 15991	4		FLOAT SWITCH KIT	48312-980	1
26	LOCK WASHER	J08 15991	4		VALUPRIME DECAL	38812-112	2
27	HEX NUT	D08 15991	4	OPTIONAL:			
28	HEX HEAD CAP SCREW	22645-164	6		BATTERY	29331-524	1

ILLUSTRATION

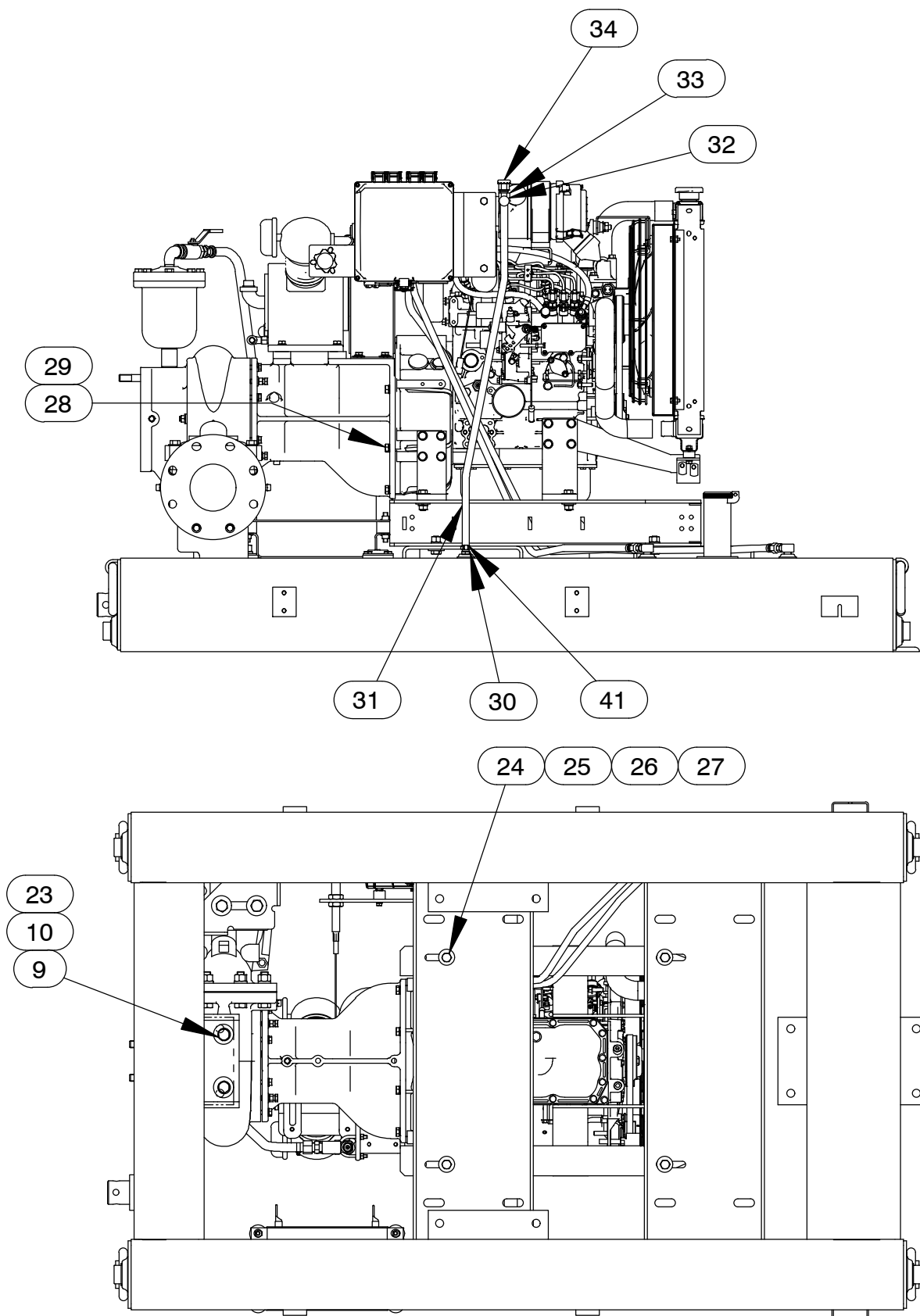

Figure 2. Pump Model VPA4A60C-3CH1 FT4 (cont'd)

**PARTS LIST**  
**Pump Model VPA4A60C-3CH1 FT4 (cont'd)**

ITEM NO.	PART NAME	PART NUMBER	QTY	ITEM NO.	PART NAME	PART NUMBER	QTY
1	PUMP END ASSEMBLY	46183-600	1	29	LOCK WASHER	21171-511	6
2	ISUZU ENGINE 3CH1 FT4	29223-431	1	30	HOSE BARB FITTING	26523-389	1
3	BASE/FUEL TANK ASSY	41553-060 24150	1	31	.37 ID X 30" LG HOSE	18513-302	1
4	LIFT BAIL ASSEMBLY	44715-062 24150	1	32	CABLE TIE	27111-218	1
5	FUEL PICKUP	29332-147	2	33	HOSE BARB FITTING	26523-447	1
6	CONNECTOR	S1447	2	34	AIR VENT	S1703	1
7	HOSE BARB FTG	26523-016	2	35	1/0 POS. CABLE ASSY	47311-108	1
8	LOCKING FUEL CAP	29332-111	1	36	1/0 NEG. CABLE ASSY	47311-159	1
9	HEX HEAD CAP SCREW	B1006 15991	10	37	BATTERY BOX, 34 FRAME	42432-015	1
10	LOCK WASHER	J10 15991	10	38	HEX NUT	D04 15991	4
11	HEX NUT	D10 15991	8	39	LOCKWASHER	J04 15991	4
12	MECH FUEL GAUGE	29332-172	1	40	SUPPORT BRACKET	34144-059 15080	1
13	SCKT HEAD CAP SCREW	BD#10-03S 15991	5	41	HOSE CLAMP	26518-642	1
14	HEX HEAD CAP SCREW	B0604 15991	2	NOT SHOWN:			
15	LOCK WASHER	J06 15991	2		ENGINE START-UP TAG	38816-269	1
16	HEX NUT	D06 15991	2		WARNING DECAL	2613FE	1
17	CNTRL PNL INSTALL KIT	48122-544	1		CAUTION DECAL	2613FJ	1
18	CNTRL PANEL BRACKET	34518-025 15080	1		G-R DECAL 6 IN	GR-06	2
19	STUD MOUNT	24631-014	4		FUEL DECAL	38816-196	1
20	HOSE CLAMP	26518-641	2		ENG OPERATION DECAL	38816-347	1
21	.31 ID X 48" LG HOSE	18513-053	1		INSTRUCTION DECAL	38818-144	1
22	.31 ID X 48" LG HOSE	18513-053	1		WARNING DECAL	38816-345	2
23	FLAT WASHER	K10 15991	6		WARNING DECAL	38817-101	2
24	HEX HEAD CAP SCREW	B0805 15991	4		WARNING DECAL	38816-203	4
25	FLAT WASHER	K08 15991	4		FLOAT SWITCH KIT	48312-980	1
26	LOCK WASHER	J08 15991	4		VALUPRIME DECAL	38812-112	2
27	HEX NUT	D08 15991	4	OPTIONAL:			
28	HEX HEAD CAP SCREW	22645-164	6		BATTERY	29331-524	1

ILLUSTRATION

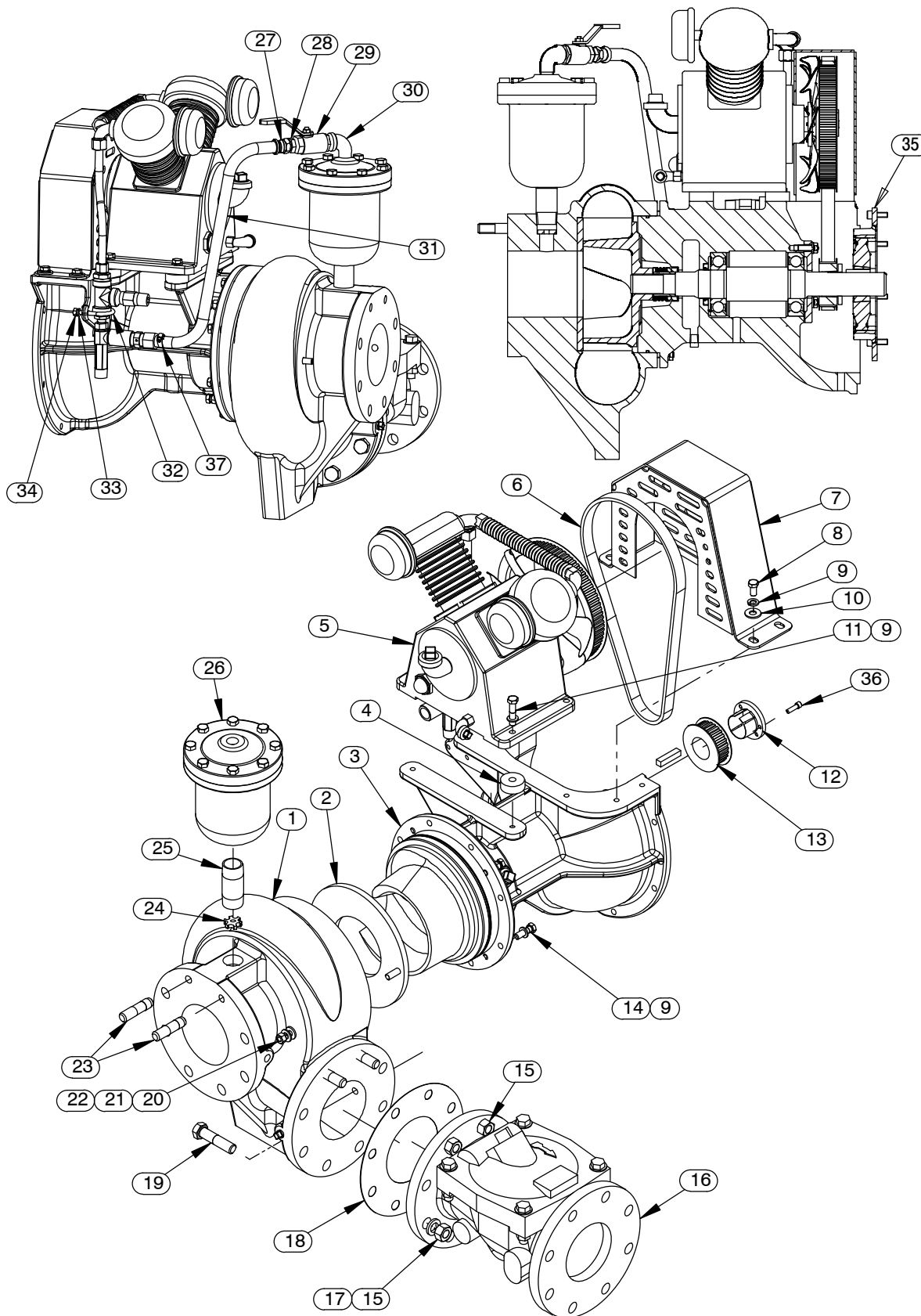

Figure 3. Pump End Assembly

## PARTS LIST

### Pump End Assembly

ITEM NO.	PART NAME	PART NUMBER	QTY	ITEM NO.	PART NAME	PART NUMBER	QTY
1	PUMP CASING ASSY	46474-916	1	23	STUD	C1010 15991	2
2 *	WEAR PLATE ASSY	12068 15990	1	24	STRAINER SCREEN	38352-028 17000	1
3	REPAIR ROTATING ASSY	44163-725	1	25	HVY PIPE NIPPLE	THA1612 15079	1
4	SPACER	31141-032 13000	4	26	PRIMING VALVE	26664-009	1
5	AIR COMP ASSY	46181-910	1		-ORIFICE BUTTON	26688-031	1
6 *	SYNCHRONOUS BELT	24186-006	1		-GASKET	26688-032	1
7	BELT GUARD ASSY	42353-027 24150	1	27	HOSE BARB FTG	26523-047	1
8	HEX HEAD CAP SCREW	B0604 15991	4	28	CONNECTOR	S1598	1
9	LOCK WASHER	J06 15991	16	29	BALL VALVE 1/2"	26631-052	1
10	FLAT WASHER	K06 15991	4	30	STREET ELBOW	RS08 11999	1
11	HEX HEAD CAP SCREW	B0607 15991	4	31	HOSE .50 ID X 18" LG	18513-113	1
12	BUSHING H 1-1/2	24131-620	1	32	U BOLT	21751-019	1
13	SPROCKET	24271-120	1	33	LOCK WASHER	J04 15991	2
14	HEX HEAD CAP SCREW	B0605 15991	8	34	HEX NUT	D04 15991	2
15	HEX NUT	D10 15991	8	35	COUPLING KIT	48112-025	1
16	CHECK VALVE 4"	26642-145	1	36	SCKT HEAD CAP SCREW	BD0403-1/2 15991	2
	-FLAPPER	26688-005	1	37	HOSE CLAMP	26518-642	1
	-O-RING	25152-366	1	NOT SHOWN:			
17	LOCK WASHER	J10 15991	6		NAMEPLATE BLANK	38819-004 13000	1
18 *	GASKET	25113-034	1		DRIVE SCREW	BM#04-03 17000	4
19	HEX HEAD CAP SCREW	B1011 15991	6		WARNING DECAL	38817-102	2
20	HEX NUT	D06 15991	2		SUCTION STICKER	6588AG	1
21 *	SEALING WASHER 3/8	25123-026	2		DISCHARGE STICKER	6588BJ	1
22	FLAT WASHER	KE06 15991	2		G-R DECAL	GR-02	1
					4" STRAINER ASSEMBLY	2690C 24000	1

\* INDICATES PARTS RECOMMENDED FOR STOCK

ILLUSTRATION

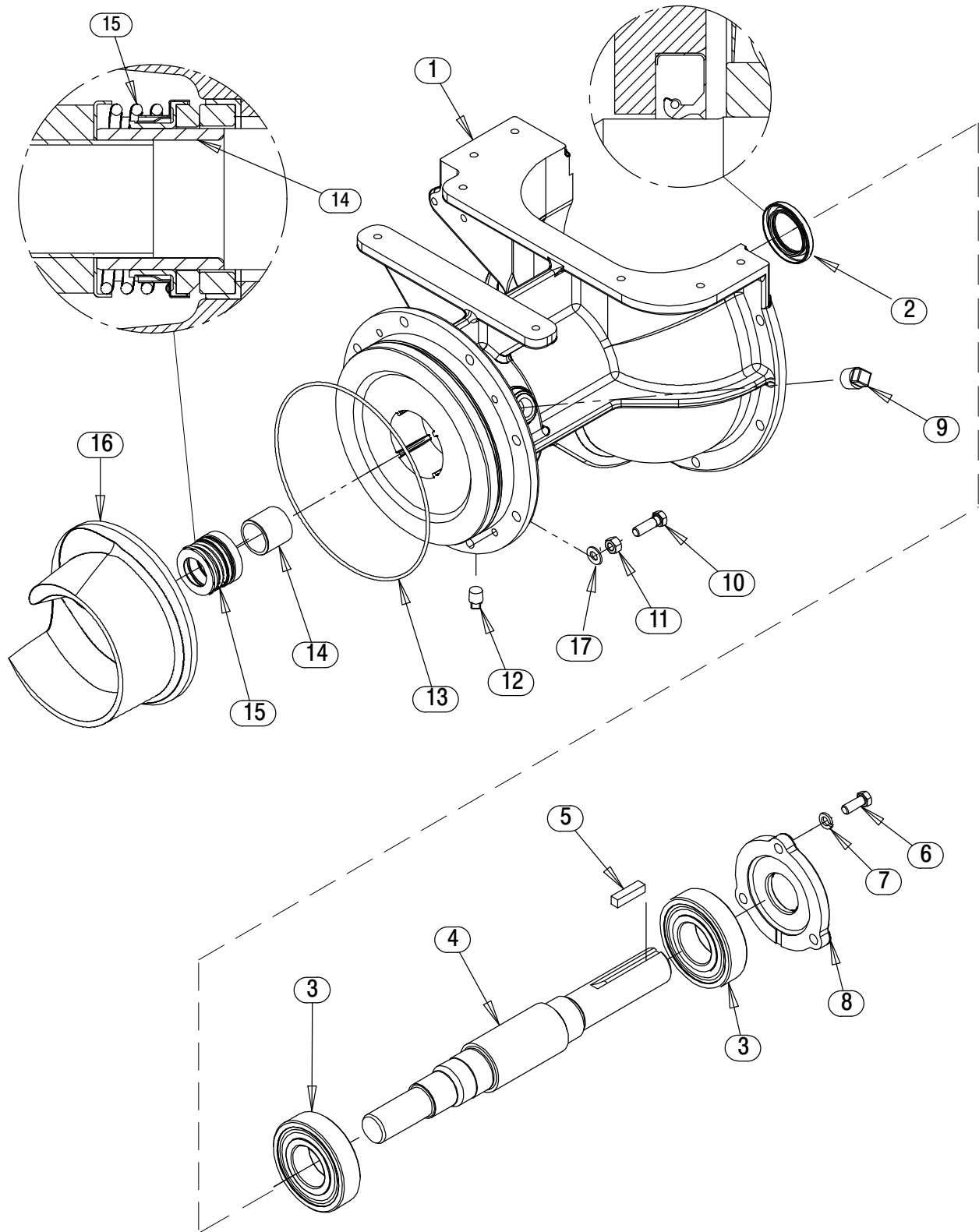

Figure 4. Repair Rotating Assembly

**PARTS LIST**  
**Repair Rotating Assembly**

ITEM NO.	PART NAME	PART NUMBER	QTY
1	INTERMEDIATE	38263-508 10000	1
2	* OIL SEAL	25258-575	1
3	* BEARING	23282-010	2
4	* IMPELLER SHAFT	38514-848 16040	1
5	* SHAFT KEY	N0606 15990	1
6	HEX HEAD CAP SCREW	B0604 15991	3
7	LOCK WASHER	J06 15991	3
8	BEARING CAP	38326-430 10000	1
9	PIPE PLUG	P08 15079	1
10	HEX HEAD CAP SCREW	B0605 15991	4
11	HEX NUT	D06 15991	4
12	PIPE PLUG	P04 15079	1
13	* O-RING	25152-267	1
14	* SHAFT SLEEVE	31414-085 16000	1
15	* MECH SEAL	25285-861	1
16	IMPELLER	38615-127 11010	1
17	FLAT WASHER	KE06 15991	4

\* INDICATES PARTS RECOMMENDED FOR STOCK

ILLUSTRATION

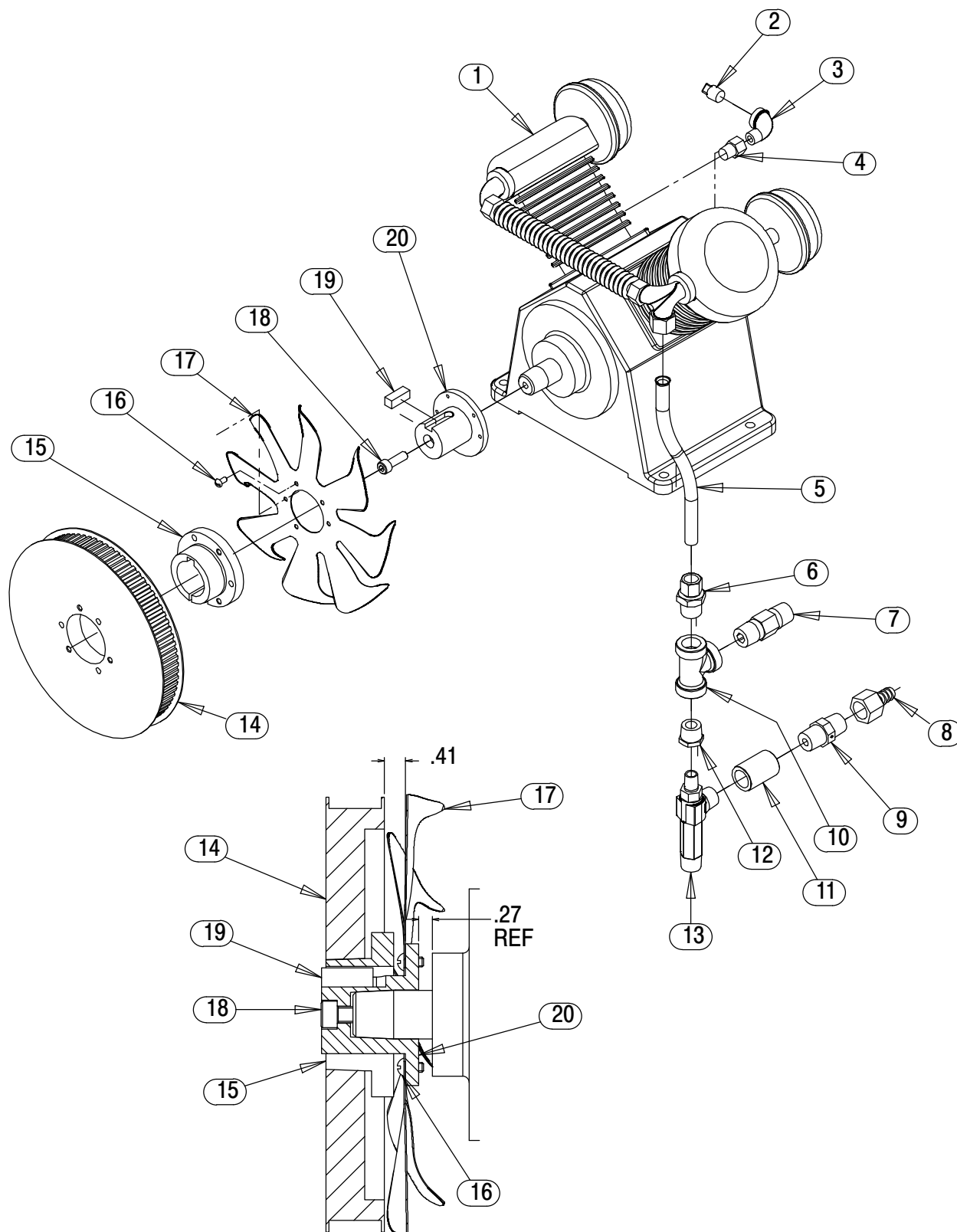

COMPRESSOR DETAIL

Figure 5. Air Compressor Assembly



**PARTS LIST**  
**Air Compressor Assembly**

ITEM NO.	PART NAME	PART NUMBER	QTY
1	COMPRESSOR	26813-113	1
2	PIPE PLUG	P04 15079	1
3	STREET ELBOW	RS04 11999	1
4	HYD HOSE ADAPTER	26813-952	1
5	TUBE	31962-001 14090	1
6	COMPRESSION FITTING	26311-067	1
7	PRESSURE RELIEF VALVE	26662-028	1
8	HOSE BARB FITTING	26523-446	1
9	1/2" CHECK VALVE	26641-092	1
10	PIPE TEE	U08 11999	1
11	PIPE CPLG 1/2	AE08 15079	1
12	REDUCER PIPE BUSHING	AP0804 15079	1
13	VENTURI	26817-003	1
14	SPROCKET	24271-005	1
15	BUSHING SDS 1.50	24131-555	1
16	MACHINE SCREW	CF#10-01-1/2 17000	5
17	FAN	26813-951	1
18	SOCKET HEAD CAP SCREW	22644-211	1
19	KEY	N0604 15990	1
20	ADAPTER HUB	31531-023 16000	1
NOT SHOWN:			
	WARNING DECAL	38817-101	1

\* INDICATES PARTS RECOMMENDED FOR STOCK

ILLUSTRATION

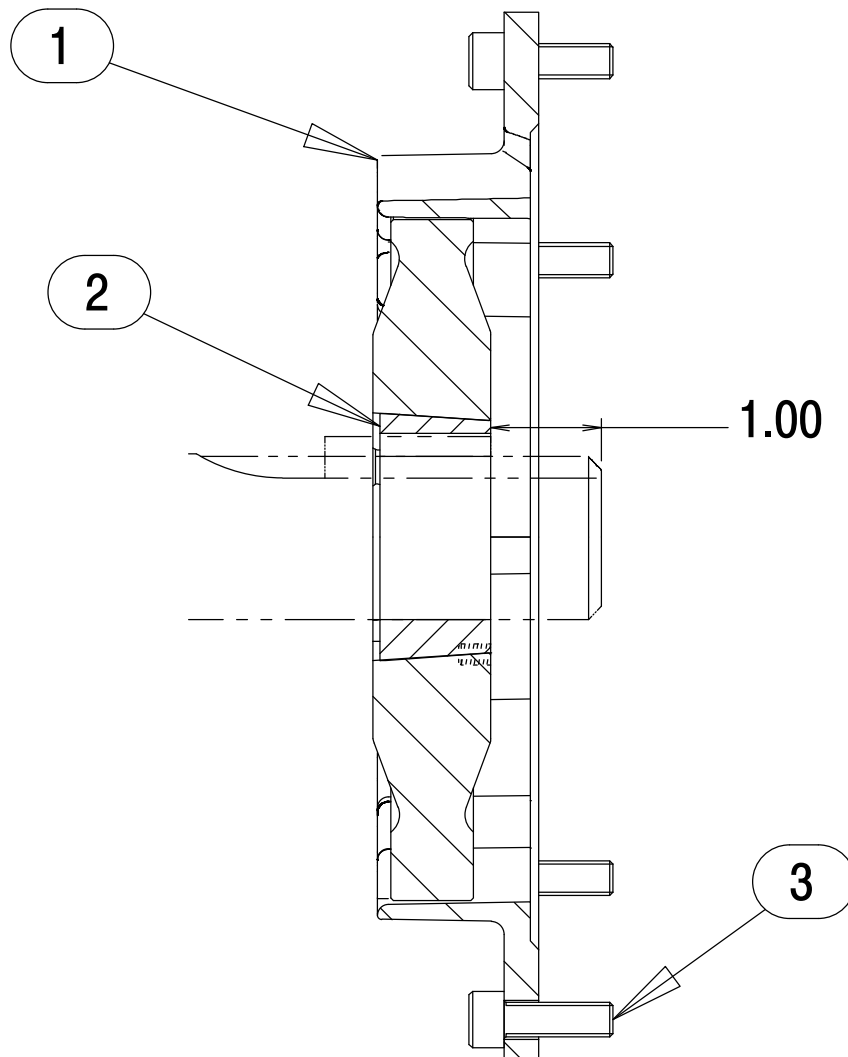

Figure 6. Coupling Kit  
PARTS LIST

ITEM NO.	PART NAME	PART NUMBER	QTY
1	COUPLING	24391-118	1
2	BUSHING 1610 X 1-1/2	24131-862	1
3	SOC HD CAP SCREW	22644-211	8

## PUMP AND SEAL DISASSEMBLY AND REASSEMBLY

Review all SAFETY information in Section A.

Follow the instructions on all tags, label and decals attached to the pump.

This pump requires little service due to its rugged, minimum-maintenance design. However, if it becomes necessary to inspect or replace the wearing parts, follow these instructions which are keyed to the Sectional Views (see Figures 1 through 6) and the corresponding Parts Lists. Maintenance and repair instructions for the engine and air compressor are covered separately in the specific literature supplied by the manufacturers.

Some pump service functions may be performed without separating the pump end assembly from the engine. However, the priming valve (26, Figure 3) and discharge check valve assembly (16, Figure 3) must be removed to service most pump components. The following instructions assume complete disassembly of the pump is required.

Before attempting to service the pump, shut down the engine and take precautions to ensure that it will remain inoperative. Close all valves in the suction and discharge lines and drain the pump casing by removing the casing drain plug. Clean and reinstall the drain plug.



This manual will alert personnel to known procedures which require special attention, to those which could damage equipment, and to those which could be dangerous to personnel. However, this manual cannot possibly anticipate and provide detailed instructions and precautions for every situation that might occur during maintenance of the unit. Therefore, it is the responsibility of the owner/maintenance personnel to ensure that only safe, established maintenance procedures are used, and that any procedures not addressed in this manual are performed only after estab-

lishing that neither personal safety nor pump integrity are compromised by such practices.



Before attempting to open or service the pump:

1. Familiarize yourself with this manual.
2. Shut down the engine and disconnect the positive battery cable to ensure that the pump will remain inoperative.
3. Allow the pump to completely cool if overheated.
4. Check the temperature and make sure it is cool before opening any covers, plates, gauges, or plugs.
5. Close the suction and discharge valves.
6. Vent the pump slowly and cautiously.
7. Drain the pump.



Death or serious personal injury and damage to the pump or components can occur if proper lifting procedures are not observed. Make certain that hoists, chains, slings or cables are in good working condition and of sufficient capacity and that they are positioned so that loads will be balanced and the pump or components will not be damaged when lifting. Suction and discharge hoses and piping must be removed from the pump before lifting. Lift the pump or component only as high as necessary and keep personnel away from suspended objects.

**WARNING!**

This pump is designed to handle material which could cause illness through direct exposure or emitted fumes. Wear adequate protective clothing when working on the pump or piping.

**WARNING!**

This pump is equipped with an automatic starting system, and is subject to automatic restart. Keep hands and clothing away from the unit to prevent injury during automatic operation. Disconnect the positive battery cable before performing any maintenance. Failure to do so may result in serious personal injury.

**CAUTION**

Use **Only Genuine Gorman-Rupp** replacement parts. Failure to do so may create a hazard and damage the pump or diminish optimal pump performance. Any such hazard, damage or diminished performance is not covered by the warranty.

**NOTE**

When appropriate recycling facilities are available, the user should recycle components and fluids when doing any routine maintenance / repairs and also at the end of the pump's useful life. All other components and fluids shall be disposed of according to all applicable codes and regulations.

**Priming Valve Removal And Disassembly**

(Figure 3)

**CAUTION**

Liquid within the priming hopper may be

pressurized. When draining liquid from the priming hopper, use caution to avoid contact with the liquid. Otherwise, injury to service personnel may occur.

Disconnect the air discharge hose (31) from the priming valve (26). Liquid will remain in the priming valve. To drain the liquid, slowly remove the pipe plug (not shown) in the valve body.

If draining is slow or difficult, the orifice in the valve may be clogged (valve requires service).

Remove and separate the priming valve (26) and nipple (25) from the pump casing assembly (1). Remove the strainer screen (24) from the pump casing and clean the strainer as necessary.

If complete replacement of the priming valve is required, unscrew the priming valve from the nipple (25).

(Figure 7)

Remove the hardware securing the priming valve cover to the priming valve body. Carefully lift the valve cover and components from the priming valve. Remove the priming valve gasket and clean the mating surfaces.

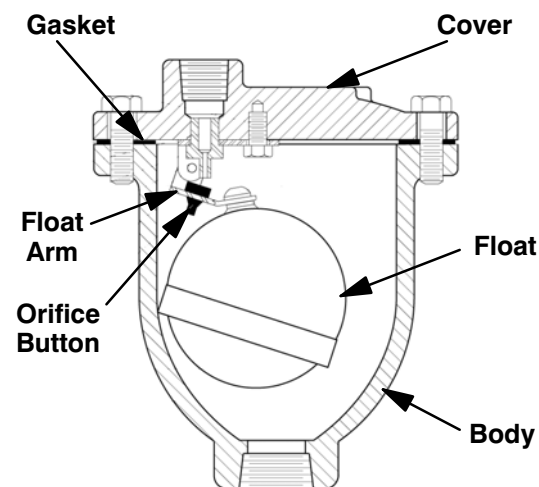
**Figure 7. Priming Valve**

If excessive liquid continues to bypass through the priming valve after the pump is fully primed, the orifice button may require replacement. Remove the old orifice button from the hole in float arm and install a new one.

## Discharge Check Valve Removal and Disassembly

### (Figure 3)

Remove the hardware (not shown) securing the discharge check valve bracket to the base.

Support the discharge check valve assembly (16) using a sling and a suitable lifting device. Remove the hardware (not shown) and separate the discharge check valve assembly and gasket (not shown) from the pump assembly (1).

The flapper and cover O-ring are the only serviceable parts of the check valve. If the flapper requires replacement, remove the hardware securing the cover. Separate the cover and O-ring and remove the flapper.

## Separating Pump and Coupling Kit From Engine

### (Figure 3)

The pump and drive assembly must be separated from the engine before further disassembly.

Disengage the hardware (8, 9 and 10) and remove the belt guard assembly (7). Remove the hardware (9 and 11) securing the air compressor assembly (5) to the intermediate (1, Figure 4). Use a pry bar to raise the air compressor high enough to remove the spacers (4). Remove the belt (6) from the air compressor drive pulley (not shown).

Disconnect all hoses and fittings from the air compressor and use a suitable hoist and sling to remove the air compressor assembly.

### (Figure 6)

Support the pump end using a hoist and sling, and remove the hardware (not shown) securing the pump casing and/or discharge check valve to the base or support bracket.

Remove the hardware (not shown) securing the intermediate (1, Figure 4) to the engine bellhousing. Separate the assemblies by pulling the intermediate straight away from the engine.

As the assemblies separate, the flexible portion of the coupling (1) will remain on the shaft. To remove

the coupling from the shaft, unscrew the two allen head setscrews from the bushing (2). Screw one of the setscrews into the puller hole on the circumference of the bushing. As the coupling and bushing separate, remove the bushing, and slide the coupling off the shaft. Remove the shaft key (5, Figure 4).

It is not necessary to remove the outer ring of the coupling from the engine flywheel unless the coupling must be replaced. To remove the ring, disengage the hardware (3) securing it to the flywheel.

Remove any leveling shims used under the casing mounting feet. Tie and tag the shims for ease of reassembly.

Move the pump end to a clean, well equipped shop area for further disassembly.

### (Figure 3)

Remove the belt (6). Remove the capscrews from the center of the bushing (12). Reinstall the capscrews in the tapped holes in the bushing and tighten them in an alternating pattern until the bushing is "jacked" out of the sprocket (13). Slide the bushing and sprocket off the shaft.

## Draining Oil From Seal Cavity

### (Figure 4)

If any further disassembly is to be performed on the pump, the seal oil cavity must be drained to prevent the oil in the seal cavity from escaping as the pump casing is removed.

Position a **clean** container under the seal cavity drain plug (12). Remove the plug and drain the oil from the seal cavity into the container. Clean and reinstall the drain plug. Inspect the oil for water, dirt or a cloudy condition which could indicate seal failure.

## Loosening Impeller

### (Figure 4)

With the pump end separated from the engine, wedge a block of wood between the vanes of the impeller (16) and the pump casing (1, Figure 3) to prevent rotation.

Install the shaft key (5) in the shaft keyway. Install a lathe dog on the drive end of the shaft (4) with the "V" notch positioned over the shaft key.

With the impeller rotation still blocked, see Figure 8 and use a long piece of heavy bar stock to pry against the arm of the lathe dog in a counterclockwise direction (when facing the drive end of the shaft). **Use caution** not to damage the shaft or keyway. When the impeller breaks loose, remove the lathe dog, key and wood block.

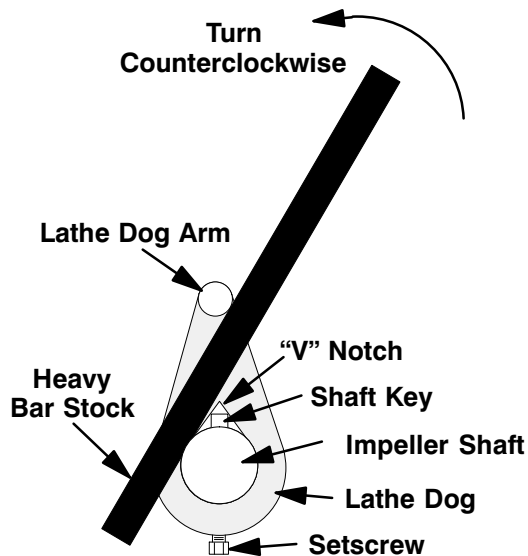

Figure 8. Loosening Impeller

### Pump Casing And Wear Plate Removal

(Figure 3)

Support the pump casing using a suitable hoist and sling.

#### NOTE

*Drain the oil from the seal cavity before removing the pump casing. See **Draining Oil From Seal Cavity**.*

Remove the hardware (9 and 14) securing the pump casing (1) to the rotating assembly (3). Pull the pump casing straight away from the rotating assembly to prevent binding on the impeller. Remove any shims supporting the pump casing. Tie and tag the shims or measure and record their thickness for ease of reassembly.

Inspect the wear plate assembly (2) for excessive wear or scoring. If replacement is required, remove the hardware (20, 21 and 22) and pull the wear plate out of the pump casing.

### Impeller Removal

(Figure 4)

With the rotating assembly removed from the pump casing, unscrew the impeller (16) from the shaft (4). Use caution when unscrewing the impeller; tension on the shaft seal spring will be released as the impeller is removed. Inspect the impeller and replace if cracked or badly worn.

### Seal Removal

(Figures 4 and 10)

Remove the spring centering washer and seal spring. Slide the shaft sleeve (14) and rotating portion of the seal (15) off the shaft as a unit. Apply oil to the sleeve and work it up under the rubber bellows. Slide the rotating portion of the seal off the sleeve.

Lay the intermediate on a flat surface with the impeller side down. Use a suitably sized dowel to press the stationary portion of the seal out of the intermediate bore.

If no further disassembly is required, see **Seal Reassembly and Installation**.

### Shaft and Bearing Removal and Disassembly

(Figure 4)

When the pump is properly operated and maintained, the intermediate should not require disassembly. Disassemble the shaft and bearings **only** when there is evidence of wear or damage.



Shaft and bearing disassembly in the field is not recommended. These operations should be performed only in a properly equipped shop by qualified personnel.

Remove the intermediate drain plug (12) and drain the lubricant. Clean and reinstall the drain plug.

Disengage the hardware (6 and 7) and remove the bearing cap (8).

Place a block of wood against the impeller end of the shaft (4) and tap the shaft and assembled bear-

ings (3) from the intermediate. Press the oil seal (2) from the intermediate.

After removing the shaft and bearings, clean and inspect the bearings **in place** as follows.

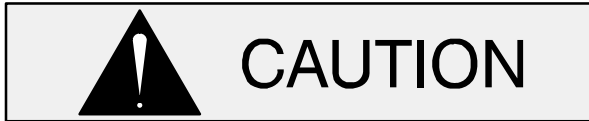

To prevent damage during removal from the shaft, it is recommended that bearings be cleaned and inspected **in place**. It is **strongly** recommended that the bearings be replaced **any** time the shaft and bearings are removed.

Clean the intermediate, shaft and all component parts with a soft cloth soaked in cleaning solvent. Inspect the parts for wear or damage and replace as necessary.



**Most cleaning solvents are toxic and flammable. Use them only in a well ventilated area free from excessive heat, sparks, and flame. Read and follow all precautions printed on solvent containers.**

Rotate the bearings by hand to check for roughness or binding. If rotation is rough, replace the bearings.

The bearing tolerances provide a tight press fit onto the shaft and a snug slip fit into the intermediate. Replace the intermediate, shaft, or bearing housing if the proper bearing fit is not achieved.

If bearing replacement is required, use a bearing puller to remove the inboard and outboard bearings from the shaft.

#### Shaft and Bearing Reassembly and Installation (Figure 4)

Inspect the shaft (4) for distortion, nicks or scratches, or for thread damage on the impeller end. Dress small nicks and burrs with a fine file or emery cloth. Replace the shaft if defective.

Clean and inspect the bearings as indicated in **Shaft And Bearing Removal And Disassembly**.

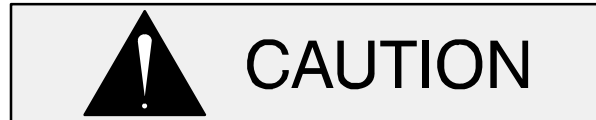

This bearing is permanently sealed and requires no additional lubrication except a coating of light oil on the external surface to ease reassembly. This surface must be kept free of all dirt and foreign material. Failure to do so could damage the bearings or the mating surface.

The bearings may be heated to ease installation. An induction heater, hot oil bath, electric oven, or hot plate may be used to heat the bearings. Bearings should **never** be heated with a direct flame or directly on a hot plate.

#### NOTE

*If a hot oil bath is used to heat the bearings, both the oil and the container must be **absolutely** clean. If the oil has been previously used, it must be **thoroughly** filtered.*

Heat the bearings to a uniform temperature **no higher than** 250° F (120° C) and slide the bearings onto the shaft, one at a time, until they are fully seated against the shaft shoulders. This should be done quickly, in one continuous motion, to prevent the bearings from cooling and sticking on the shaft.

After the bearings have been installed and allowed to cool, check to ensure that they have not moved away from the shaft shoulders in shrinking. If movement has occurred, use a suitably sized sleeve and a press to reposition the bearings against the shaft shoulders.

If heating the bearings is not practical, use a suitably sized sleeve and an arbor (or hydraulic) press to install the bearings on the shaft.



When installing the bearings onto the shaft, **never** press or hit against the outer race, balls, or ball cage. Press **only** on the inner race.

Apply a light coating of oil to the lip of the oil seal (2) and press it into the intermediate bore with the lip positioned as shown in Figure 4. Press the oil seal into the intermediate until fully seated

Lubricate the lip seal area of the shaft and slide the shaft and assembled bearings into the intermediate until the inboard bearing is fully seated in the intermediate bore.

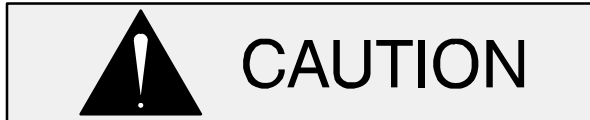

When installing the shaft and bearings into the bearing bore, push against the outer race. **Never** hit the balls or ball cage.

Install the bearing cap (8) and secure it to the intermediate with the hardware (6 and 7).

### Securing Intermediate And Coupling Kit To Engine

(Figure 3)

Install the inboard key supplied with bushing (13) making sure to leave room in the keyway for the drive key (5, Figure 4). Install the sprocket (14) and bushing (13) on the shaft to the dimension shown in Figure 9.

#### NOTE

When properly installed to the dimension shown in Figure 9, the key (5, Figure 4) **will not** extend fully through the bushing. This is an acceptable fit for this application.

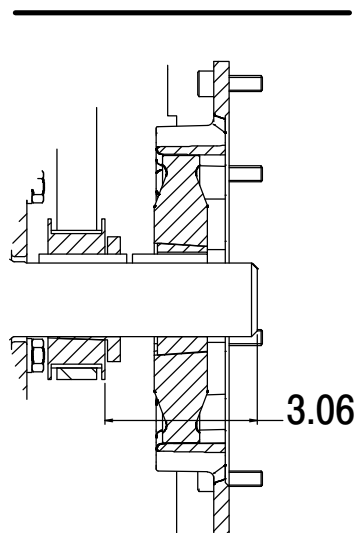

Figure 9. Drive Sprocket Positioning

Secure the bushing and sprocket to the shaft by torquing the bushing screws to 9 ft. lbs. (1,2 m. kg.). Install the belt (6) over the sprocket and install the coupling kit (35) as follows.

(Figure 6)

#### NOTE

The flexible portion of the coupling must be properly positioned on the shaft. The bushing (2) and coupling (1) **must be installed with the bushing set screw positioned toward the drive end of the shaft.**

Install the shaft key (5, Figure 4) in the shaft keyway. Align the keyway in the bushing (2) with the shaft key, and slide the bushing onto the shaft to the dimension shown in Figure 9. Rotate the flexible portion of the coupling until the tapped holes for the two setscrews align with those in the bushing, and install the setscrews.



Make certain that the flexible portion of the coupling is mounted as shown in Figure 6. **This positioning is critical.** If the coupling is not properly positioned on the shaft, the coupling parts may not fully engage, or a pre-load condition can cause premature bearing failure.

The end of the shaft must be extended 1 inch (25,4 mm) from the face of the bushing. This will allow the two portions of the coupling to fully engage when the intermediate is secured to the engine bellhousing, without pre-loading the bearings.

With the flexible portion of the coupling and the bushing properly positioned on the shaft, tighten the two setscrews in an alternating sequence until the bushing and coupling are fully secured. Torque the setscrews to 0.9 ft. lbs. (175 in. lbs. or 0,13 m. kg.).

If the complete coupling assembly is being replaced, apply 'Loctite Retaining Compound No. 242' or equivalent to the threads of the hardware (3), and secure the outer ring of the coupling to the



engine flywheel by torquing the hardware to 16 ft. lbs. (192 in. lbs. or 2,2 m. kg.).

Using a suitable lifting device, position the assembled intermediate and coupling kit so the flexible portion of the coupling seats inside the outer ring attached to the engine flywheel.

### NOTE

To ease installation, **lightly** lubricate the rubber portion of the coupling with a **non-petroleum based lubricant** such as vegetable oil or glycerin, or a silicon-based lubricant such as "WD40" or equivalent. **Do not** use petroleum-based lubricants, or any other substance which may soften or otherwise damage the rubber.

Secure the intermediate to the engine bellhousing with the previously removed hardware (not shown).

### (Figure 3)

Use a suitable hoist and sling to position the air compressor assembly (5) on the intermediate (1, Figure 4). Slide the belt (6) over the air compressor sprocket. Use a pry bar to raise the compressor high enough to install the spacers (4) between the compressor and the mounting flange. Secure the compressor to the intermediate with the hardware (9 and 11). Reinstall the guard (7) and secure it with the hardware (8, 9 and 10).

### Seal Reassembly and Installation

#### (Figures 4 and 10)

Inspect the shaft sleeve for damage. Small scratches or nicks may be removed with a emery cloth or a fine file. If excessive wear exists, replace the shaft sleeve.

Clean the seal cavity and shaft with a cloth soaked in fresh cleaning solvent.



**Most cleaning solvents are toxic and flammable. Use them only in a well-ventilated area free from excessive heat, sparks, and flame. Read and follow all precautions printed on solvent containers.**

The seal is not normally reused because wear patterns on the finished faces cannot be realigned during reassembly. This could result in premature failure. If necessary to reuse an old seal in an emergency, **carefully** wash all metallic parts in fresh cleaning solvent and allow to dry thoroughly.

Handle the seal parts with extreme care to prevent damage. Be careful not to contaminate precision finished faces; even fingerprints on the faces can shorten seal life. If necessary, clean the faces with a non-oil based solvent and a clean, lint-free tissue. Wipe **lightly** in a concentric pattern to avoid scratching the faces.

Inspect the seal components for wear, scoring, grooves, and other damage that might cause leakage. Clean and polish the shaft sleeve, or replace it if there are nicks or cuts on either end. If any components are worn, replace the complete seal; **never mix old and new seal parts.**

If a replacement seal is being used, remove it from the container and inspect the precision finished faces to ensure that they are free of any foreign matter.

To ease installation of the seal, lubricate the shaft sleeve and bellows with a very small amount of "P-80" Emulsion or water and apply a drop of light lubricating oil on the finished seal faces. Assemble the seal as follows (see Figure 10).

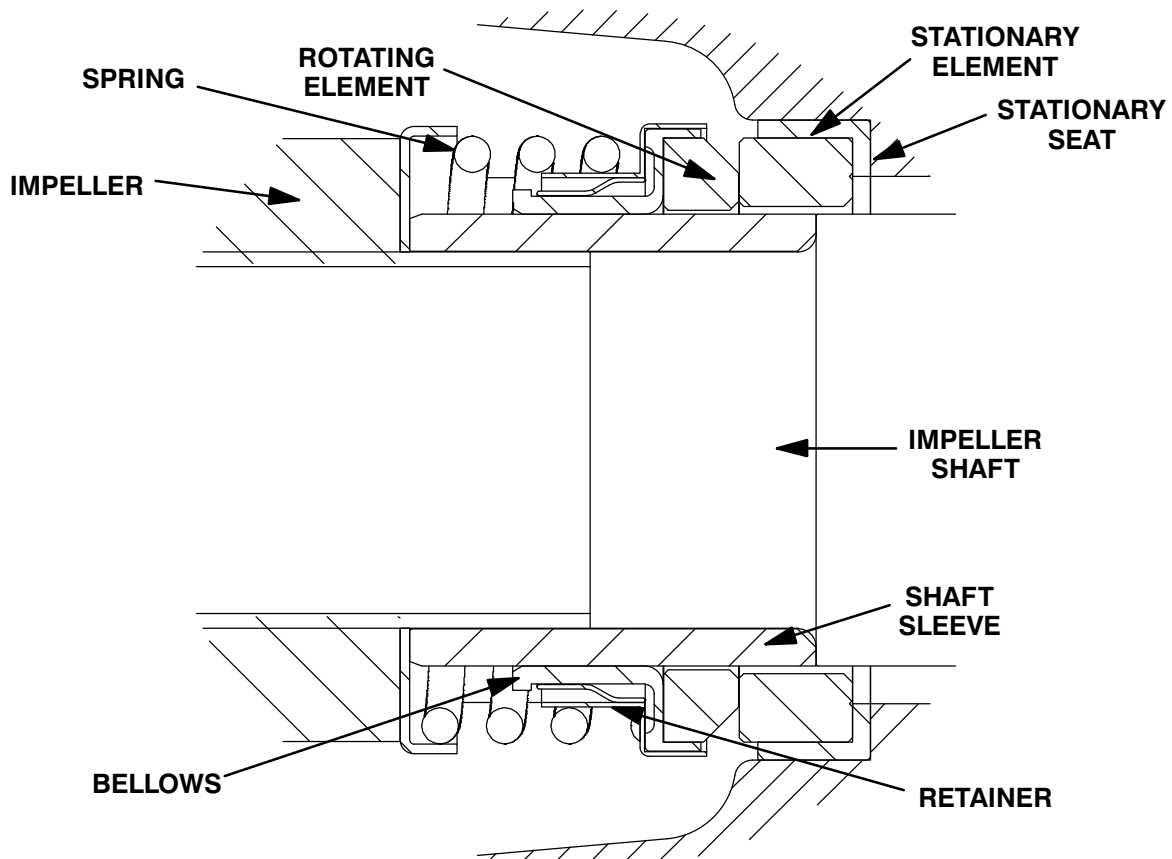
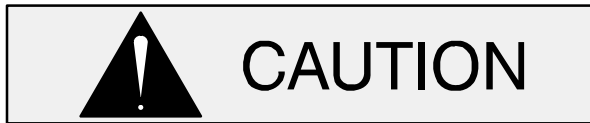

Figure 10. Seal Assembly



This seal is not designed for operation at temperatures above 160°F (71°C). Do not use at higher operating temperatures.

Lightly lubricate the O.D. of the stationary seat and use your thumbs to press the stationary seat and element into the intermediate bore until fully seated.

Slide the rotating portion of the seal (consisting of the rotating element, retainer and bellows) onto the shaft sleeve (14) until the face of the rotating element is **just flush** with the end of the sleeve that is chamfered on the I.D.

Slide the assembled seal and shaft sleeve onto the shaft until the seal faces contact. Continue to push the sleeve through the seal until the chamfered end seats firmly against the shaft shoulder.

Install the seal spring spring centering washer.

### Impeller Installation And Adjustment

(Figure 4)

Inspect the impeller (16) and replace it if cracked or badly worn.



The shaft and impeller threads **must** be completely clean before reinstalling the impeller. Even the slightest amount of dirt on the threads can cause the impeller to seize to the shaft, making future removal difficult or impossible without damage to the impeller or shaft.

Apply a small amount of 'Never-Seez' or equivalent anti-lock compound on the shaft threads. Screw the impeller onto the shaft until tight.

### NOTE

*At the slightest sign of binding, **immediately** back the impeller off, and check the threads for dirt. **Do not** try to force the impeller onto the shaft.*

A clearance of .025 to .040 inch (0,64 to 1,02 mm) between the impeller and the seal plate is necessary for maximum pump efficiency. Measure this clearance, and add or remove impeller adjusting shims as required.

### Pump Casing And Wear Plate Installation

#### (Figure 3)

If the wear plate (2) was removed, position the replacement wear plate in the pump casing (1). Install the sealing washers (21) on the wear plate studs. Install the lock washers and hex nuts (20 and 22). Tighten the nuts in an alternating pattern until the wear plate is fully seated in the casing bore.

#### NOTE

*When installing the wear plate, do not over-tighten the hex nuts (20). This could crush the sealing washers, which would allow liquid to leak from around the wear plate studs.*

Loosen the jam nuts (11, Figure 4) and unscrew the adjusting screws (10, Figure 4), then secure the pump casing to the rotating assembly (3) with the hardware (9 and 14). Do not fully tighten the capscrews until the impeller face clearance has been set.

A clearance of .010 to .020 inch (0,25 to 0,5 mm) between the impeller and the wear plate is recommended for maximum pump efficiency. Reach through the pump suction opening with a feeler gauge to measure this clearance. Use the adjusting screws to obtain the desired clearance, then lock the adjusting screws in place with the jam nuts.

After the face clearance has been set, tighten the hardware securing the rotating assembly to the pump casing.

Reinstall any leveling shims used under the pump casing and secure the casing (1) to the base with the previously removed hardware.

### Discharge Check Valve Reassembly And Installation

#### (Figure 3)

If the discharge check valve (16) was disassembled to replace the flapper or cover O-ring, position the flapper in the valve body and check to ensure free movement.

Install the valve cover O-ring and secure the cover to the body with the previously removed hardware.

Apply a small amount of light grease to the discharge flange gasket to hold it in place and position it against the pump casing flange. Support the discharge check valve assembly using a sling and a suitable lifting device. Using the previously removed hardware, secure the discharge check valve assembly and flange gasket to the pump assembly (1).

### Priming Valve Reassembly And Installation

#### (Figures 3 and 7)

Clean and inspect the components of the priming valve. Inspect the linkage and ensure the orifice button squarely engages the valve seat. Replace the orifice button if required (see **Priming Valve Removal and Disassembly** for orifice button removal).

Gorman-Rupp provides replacement parts for the cover gasket and the orifice button. If any of the other priming valve components are worn or damaged, they must be replaced before reinstalling the priming valve. For additional parts and service instructions for the valve, Contact the **Val-Matic Valve and Manufacturing Corporation**, or go to **www.valmatic.com** on the World Wide Web. Reference Val-Matic Model Number 25.5.

After servicing the priming valve components, reinstall the priming valve cover gasket and secure the cover to the valve body with the previously removed hardware.

If the complete priming valve is being replaced, clean the strainer screen (24) and install the screen and nipple (25) in the pump casing. Screw the replacement valve onto the nipple (25).

Reconnect the air discharge tubing to the priming chamber assembly.

## LUBRICATION

(Figure 4)

### Seal Assembly

Before starting the pump, remove the pipe plug (9) and fill the seal cavity with approximately 10 ounces (0,3 liter) of SAE No. 30 non-detergent oil or to the bottom of the pipe plug hole in the inter-

mediate. Clean and reinstall the pipe plug. Maintain the oil level at the bottom of the pipe plug hole.

### Bearings

(Figure 4)

The bearings used in this pump are permanently lubricated and sealed from the manufacturer. No additional bearing lubrication is required.

### Engine

Consult the literature supplied with the engine, or contact your local engine representative.

**For Warranty Information, Please Visit  
[www.grpumps.com/warranty](http://www.grpumps.com/warranty)  
or call:  
U.S.: 419-755-1280  
Canada: 519-631-2870  
International: +1-419-755-1352**

**GORMAN-RUPP PUMPS**