**INSTALLATION, OPERATION,
AND MAINTENANCE MANUAL**
WITH PARTS LIST



SUPER T SERIES PUMP

MODEL
T10A65S-6068T

THE GORMAN-RUPP COMPANY • MANSFIELD, OHIO

GORMAN-RUPP OF CANADA LIMITED • ST. THOMAS, ONTARIO, CANADA Printed in U.S.A.

www.grpumps.com

©2003 The Gorman-Rupp Company

Register your new
Gorman-Rupp pump online at
www.grpumps.com

Valid serial number and e-mail address required.



The engine exhaust from this product contains chemicals known to the State of California to cause cancer, birth defects or other reproductive harm.

RECORD YOUR PUMP MODEL AND SERIAL NUMBER

Please record your pump model and serial number in the spaces provided below. Your Gorman-Rupp distributor needs this information when you require parts or service.

Pump Model: _____

Serial Number: _____

TABLE OF CONTENTS

INTRODUCTION	PAGE I – 1
SAFETY - SECTION A	PAGE A – 1
INSTALLATION – SECTION B	PAGE B – 1
Pump Dimensions	PAGE B – 1
PREINSTALLATION INSPECTION	PAGE B – 2
Battery Specifications And Installation	PAGE B – 2
POSITIONING PUMP	PAGE B – 2
Lifting	PAGE B – 2
Mounting	PAGE B – 3
Clearance	PAGE B – 3
SUCTION AND DISCHARGE PIPING	PAGE B – 3
Materials	PAGE B – 3
Line Configuration	PAGE B – 3
Connections to Pump	PAGE B – 3
Gauges	PAGE B – 3
SUCTION LINES	PAGE B – 3
Fittings	PAGE B – 3
Strainers	PAGE B – 4
Sealing	PAGE B – 4
Suction Lines In Sumps	PAGE B – 4
Suction Line Positioning	PAGE B – 4
FLOAT SWITCHES	PAGE B – 5
Installation	PAGE B – 5
OPTIONAL SUBMERSIBLE TRANSDUCER	PAGE B – 6
DISCHARGE LINES	PAGE B – 7
Siphoning	PAGE B – 7
Valves	PAGE B – 7
Bypass Lines	PAGE B – 7
AUTOMATIC AIR RELEASE VALVE	PAGE B – 8
Theory of Operation	PAGE B – 8
Air Release Valve Installation	PAGE B – 9
ALIGNMENT	PAGE B – 10
OPERATION – SECTION C	PAGE C – 1
PRIMING	PAGE C – 1
STARTING	PAGE C – 2
Manual Starting	PAGE C – 2
Automatic Starting	PAGE C – 2
OPTIONAL EPS CONTROL	PAGE C – 2
Features	PAGE C – 2
Functional Description	PAGE C – 2
EPS Functions	PAGE C – 3
EPS Calibration	PAGE C – 4
Zero Adjustment	PAGE C – 4
Span Adjustment	PAGE C – 4
Level Adjustment	PAGE C – 4

TABLE OF CONTENTS
(continued)

Horn Delay	PAGE C – 5
OPERATION	PAGE C – 5
Lines With a Bypass	PAGE C – 5
Lines Without a Bypass	PAGE C – 5
Leakage	PAGE C – 5
Liquid Temperature And Overheating	PAGE C – 5
Strainer Check	PAGE C – 6
Pump Vacuum Check	PAGE C – 6
STOPPING	PAGE C – 6
Manual Stopping	PAGE C – 6
Automatic Stopping	PAGE C – 6
Safety Shutdown System	PAGE C – 6
OPERATION IN EXTREME HEAT	PAGE C – 7
Cold Weather Preservation	PAGE C – 7
BEARING TEMPERATURE CHECK	PAGE C – 7
TROUBLESHOOTING – SECTION D	PAGE D – 1
PREVENTIVE MAINTENANCE	PAGE D – 4
PUMP MAINTENANCE AND REPAIR - SECTION E	PAGE E – 1
STANDARD PERFORMANCE CURVE	PAGE E – 1
PARTS LISTS:	
Pump Model	PAGE E – 3
Power Unit Kit	PAGE E – 5
Pump End Assembly	PAGE E – 7
Repair Rotating Assembly	PAGE E – 9
Drive Assembly	PAGE E – 10
PUMP AND SEAL DISASSEMBLY AND REASSEMBLY	PAGE E – 11
Cleanout Access And Suction Check Valve Removal	PAGE E – 11
Suction Head And Wear Plate Removal	PAGE E – 12
Separating Pump And Drive Assembly From Engine	PAGE E – 12
Loosening Impeller	PAGE E – 12
Rotating Assembly Removal	PAGE E – 13
Impeller And Wear Plate Removal	PAGE E – 13
Seal Removal And Disassembly	PAGE E – 13
Shaft and Bearing Removal and Disassembly	PAGE E – 14
Shaft and Bearing Reassembly and Installation	PAGE E – 14
Seal Reassembly And Installation	PAGE E – 16
Impeller Installation	PAGE E – 19
Rotating Assembly Installation	PAGE E – 19
Suction Head And Wear Plate Installation	PAGE E – 19
Suction Check Valve Installation	PAGE E – 20
Securing Pump End To Engine	PAGE E – 20
PRESSURE RELIEF VALVE MAINTENANCE	PAGE E – 21
LUBRICATION	PAGE E – 21
Seal Assembly	PAGE E – 21
Bearings	PAGE E – 21
Engine	PAGE E – 21

INTRODUCTION

Thank You for purchasing a Gorman-Rupp pump. **Read this manual** carefully to learn how to safely install and operate your pump. Failure to do so could result in personal injury or damage to the pump.

This Installation, Operation, and Maintenance manual is designed to help you achieve the best performance and longest life from your Gorman-Rupp pump.

This pump is a Super T Series, semi-open impeller, self-priming centrifugal model with a suction check valve. The pump also is designed with external shimless adjusters for setting the wear plate to impeller clearance. The pump is close coupled to a John Deere 6068T diesel engine, and is designed for handling mild industrial corrosives, residues or slurries containing specified entrained solids. The basic material of construction for wetted parts is grade CD4MCU stainless steel.

If there are any questions regarding the pump or its application which are not covered in this manual or in other literature accompanying this unit, please contact your Gorman-Rupp distributor, or write:

The Gorman-Rupp Company
P.O. Box 1217
Mansfield, Ohio 44901—1217
Phone: (419) 755—1011

or:

Gorman-Rupp of Canada Limited
70 Burwell Road
St. Thomas, Ontario N5P 3R7
Phone: (519) 631—2870

For information or technical assistance on the engine, contact the engine manufacturer's local dealer or representative.

Because pump installations are seldom identical, this manual cannot possibly provide detailed instructions and precautions for every aspect of each specific application. Therefore, it is the responsibility of the owner/installer of the pump to ensure that applications not addressed in this manual are performed **only** after establishing that

neither operator safety nor pump integrity are compromised by the installation. Pumps and related equipment **must** be installed and operated according to all national, local and industry standards.

The following are used to alert maintenance personnel to procedures which require special attention, to those which could damage equipment, and to those which could be dangerous to personnel:



Immediate hazards which WILL result in severe personal injury or death. These instructions describe the procedure required and the injury which will result from failure to follow the procedure.



Hazards or unsafe practices which COULD result in severe personal injury or death. These instructions describe the procedure required and the injury which could result from failure to follow the procedure.



Hazards or unsafe practices which COULD result in minor personal injury or product or property damage. These instructions describe the requirements and the possible damage which could result from failure to follow the procedure.

NOTE

Instructions to aid in installation, operation, and maintenance or which clarify a procedure.

SAFETY - SECTION A

This information applies to Super T Series engine driven pumps. Refer to the manual accompanying the engine before attempting to begin operation.

Because pump installations are seldom identical, this manual cannot possibly provide detailed instructions and precautions for each specific application. Therefore, it is the owner/installer's responsibility to ensure that applications not addressed in this manual are performed only after establishing that neither operator safety nor pump integrity are compromised by the installation.



Before attempting to open or service the pump:

1. Familiarize yourself with this manual.
2. Switch off the engine ignition, and disconnect the positive battery cable to ensure that the pump will remain inoperative.
3. Allow the pump to completely cool if overheated.
4. Check the temperature before opening any covers, plates, or plugs.
5. Close the suction and discharge valves.
6. Vent the pump slowly and cautiously.
7. Drain the pump.



This pump is equipped with an automatic starting system, and is subject to automatic restart. Keep hands and clothing away from the unit to prevent injury

during automatic operation. Disconnect the positive battery cable before performing any maintenance. Failure to do so may result in serious personal injury.



This pump is designed to handle mild industrial corrosives, residues or slurries containing specified entrained solids. Do not attempt to pump volatile, corrosive, or flammable materials which may damage the pump or endanger personnel as a result of pump failure.



Use lifting and moving equipment in good repair and with adequate capacity to prevent injuries to personnel or damage to equipment. The bail is intended for use in lifting the pump assembly only. Suction and discharge hoses and piping must be removed from the pump before lifting.



After the unit has been installed, make certain that the pump and all piping or hose connections are tight, properly supported and secure before operation.



Do not operate the pump against a closed discharge valve for long periods of time. If operated against a closed discharge valve, pump components will deteriorate, and the liquid could come

to a boil, build pressure, and cause the pump casing to rupture or explode.



This pump is designed to handle materials which could cause illness or injury through direct exposure or emitted fumes. Wear adequate protective clothing when working on the pump or piping.



Do not remove plates, covers, gauges, pipe plugs, or fittings from an overheated pump. Vapor pressure within the pump can cause parts being disengaged to be ejected with great force. Allow the pump to cool before servicing.



Do not operate an internal combustion engine in an explosive atmosphere. When operating internal combustion engines in an enclosed area, make certain that exhaust fumes are piped to the outside. These fumes contain carbon monoxide, a deadly gas that is colorless, tasteless, and odorless.



Fuel used by internal combustion engines presents an extreme explosion and fire hazard. Make certain that all fuel lines are securely connected and free of leaks. Never refuel a hot or running engine. Avoid overfilling the fuel tank. Always use the correct type of fuel.



Never tamper with the governor to gain more power. The governor establishes safe operating limits that should not be exceeded. The maximum continuous operating speed for this pump is 1750 RPM.



Pumps and related equipment must be installed and operated according to all national, local and industry standards.

INSTALLATION – SECTION B

Review all SAFETY information in Section A.

Since pump installations are seldom identical, this section offers only general recommendations and practices required to inspect, position, and arrange the pump and piping.

Most of the information pertains to a standard **static lift** application where the pump is positioned above the free level of liquid to be pumped.

If installed in a **flooded suction application** where the liquid is supplied to the pump under pressure, some of the information such as mounting, line configuration, and priming must be tailored to the

specific application. Since the pressure supplied to the pump is critical to performance and safety, **be sure** to limit the incoming pressure to 50% of the maximum permissible operating pressure as shown on the pump performance curve.

For further assistance, contact your Gorman-Rupp distributor or the Gorman-Rupp Company.

Pump Dimensions

See Figure 1 for the approximate physical dimensions of this pump.

OUTLINE DRAWING

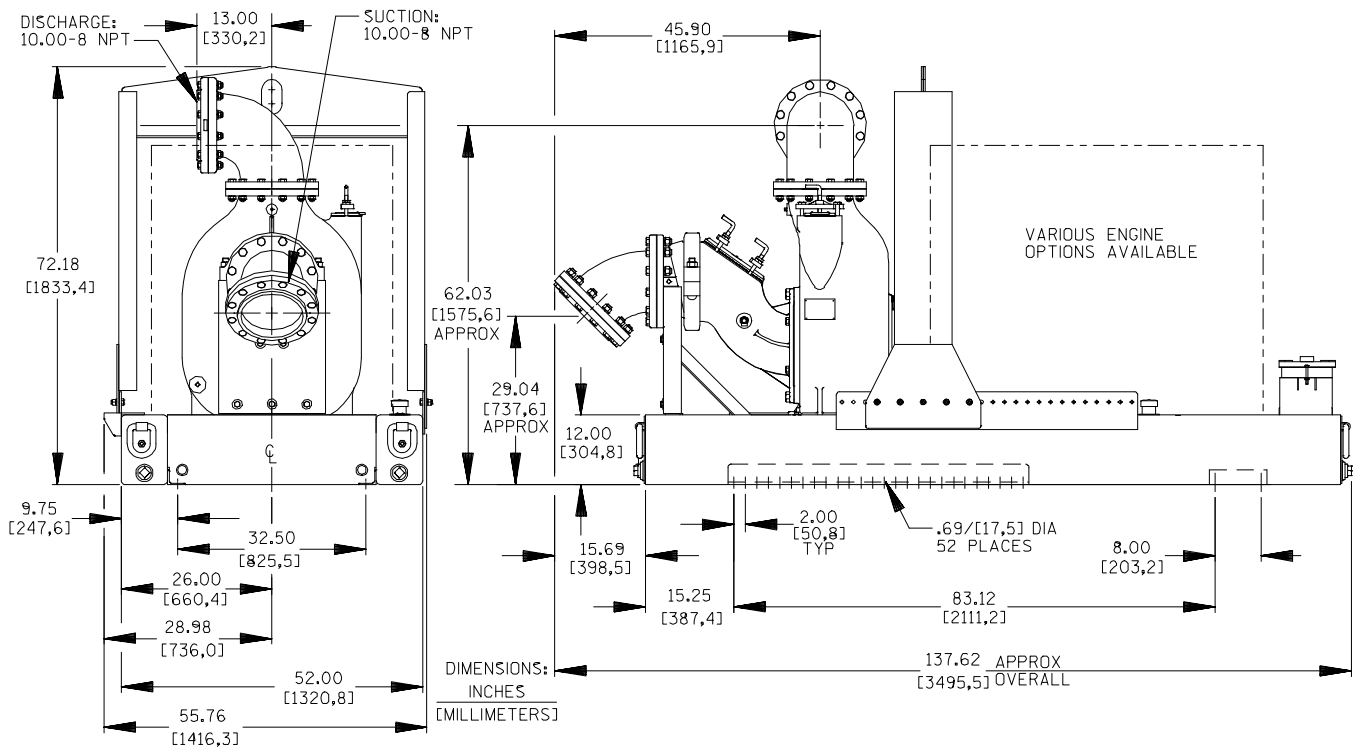

Figure 1. Pump Model T10A65S-6068T

PREINSTALLATION INSPECTION

The pump assembly was inspected and tested before shipment from the factory. Before installation, inspect the pump for damage which may have occurred during shipment. Check as follows:

- a. Inspect the pump assembly for cracks, dents, damaged threads, and other obvious damage.
- b. Check for and tighten loose attaching hardware. Since gaskets tend to shrink after drying, check for loose hardware at mating surfaces.
- c. Carefully read all tags, decals, and markings on the pump assembly, and perform all duties indicated.
- d. Check levels and lubricate as necessary. Refer to **LUBRICATION** in the **MAINTENANCE AND REPAIR** section of this manual and perform duties as instructed.
- e. If the pump and engine have been stored for more than 12 months, some of the components or lubricants may have exceeded their maximum shelf life. These **must be inspected or replaced** to ensure maximum pump service.

If the maximum shelf life has been exceeded, or if anything appears to be abnormal, contact your Gorman-Rupp distributor or the factory to determine the repair or updating policy. **Do not** put the pump into service until appropriate action has been taken.

Battery Specifications And Installation

Unless otherwise specified on the pump order, the engine battery was **not** included with the unit. Refer to the following specifications when selecting a battery.

Table 1. Battery Specifications

Voltage	Cold Crank Amps @ 0° F	Reserve Capacity @ 80° F (Minutes)	Amp/ Hr. Rating	Approx. Overall Dims. (Inches)
12 Volts	850	120	75	10.25L x 6.75W x 8.88H

Refer to the information accompanying the battery and/or electrolyte solution for activation and charging instructions.

Before installing the battery, clean the positive and negative cable connectors, and the battery terminals. Secure the battery by tightening the holddown brackets. The terminals and clamps may be coated with petroleum jelly to retard corrosion. Connect and tighten the positive cable first, then the negative cable.

POSITIONING PUMP



WARNING!

Use lifting and moving equipment in good repair and with adequate capacity to prevent injuries to personnel or damage to equipment. The bail is intended for use in lifting the pump assembly only. Suction and discharge hoses and piping must be removed from the pump before lifting.

Lifting

Pump unit weights will vary depending on the mounting and drive provided. Check the shipping tag on the unit packaging for the actual weight, and use lifting equipment with appropriate capacity. Drain the pump and remove all customer-installed equipment such as suction and discharge hoses or piping before attempting to lift existing, installed units.



CAUTION

The pump assembly can be seriously

damaged if the cables or chains used to lift and move the unit are improperly wrapped around the pump.

Mounting

Locate the pump in an accessible place as close as practical to the liquid being pumped. Level mounting is essential for proper operation.

The pump may have to be supported or shimmed to provide for level operation or to eliminate vibration.

If the pump has been mounted on a moveable base, make certain the base is stationary by setting the brake and blocking the wheels before attempting to operate the pump.

To ensure sufficient lubrication and fuel supply to the engine, **do not** position the pump and engine more than 15° off horizontal for continuous operation. The pump and engine may be positioned up to 30° off horizontal for **intermittent operation only**; however, the engine manufacturer should be consulted for continuous operation at angles greater than 15°.

Clearance

When positioning the pump, allow a minimum clearance of **18 inches (457,2 mm)** in front of the back cover to permit removal of the cover and easy access to the pump interior.

SUCTION AND DISCHARGE PIPING

Pump performance is adversely effected by increased suction lift, discharge elevation, and friction losses. See the performance curve and notes on Page E-1 to be sure your overall application allows pump to operate within the safe operation range.

Materials

Either pipe or hose maybe used for suction and discharge lines; however, the materials must be compatible with the liquid being pumped. If hose is used in suction lines, it must be the rigid-wall, reinforced type to prevent collapse under suction. Us-

ing piping couplings in suction lines is not recommended.

Line Configuration

Keep suction and discharge lines as straight as possible to minimize friction losses. Make minimum use of elbows and fittings, which substantially increase friction loss. If elbows are necessary, use the long-radius type to minimize friction loss.

Connections to Pump

Before tightening a connecting flange, align it exactly with the pump port. Never pull a pipe line into place by tightening the flange bolts and/or couplings.

Lines near the pump must be independently supported to avoid strain on the pump which could cause excessive vibration, decreased bearing life, and increased shaft and seal wear. If hose-type lines are used, they should have adequate support to secure them when filled with liquid and under pressure.

Gauges

Most pumps are drilled and tapped for installing discharge pressure and vacuum suction gauges. If these gauges are desired for pumps that are not tapped, drill and tap the suction and discharge lines not less than 18 inches (457,2 mm) from the suction and discharge ports and install the lines. Installation closer to the pump may result in erratic readings.

SUCTION LINES

To avoid air pockets which could affect pump priming, the suction line must be as short and direct as possible. When operation involves a suction lift, the line must always slope upward to the pump from the source of the liquid being pumped; if the line slopes down to the pump at any point along the suction run, air pockets will be created.

Fittings

Suction lines should be the same size as the pump inlet. If reducers are used in suction lines, they should be the eccentric type, and should be in-

stalled with the flat part of the reducers uppermost to avoid creating air pockets. Valves are not normally used in suction lines, but if a valve is used, install it with the stem horizontal to avoid air pockets.

Strainers

If a strainer is furnished with the pump, be certain to use it; any spherical solids which pass through a strainer furnished with the pump will also pass through the pump itself.

If a strainer is not furnished with the pump, but is installed by the pump user, make certain that the total area of the openings in the strainer is at least three or four times the cross section of the suction line, and that the openings will not permit passage of solids larger than the solids handling capability of the pump.

This pump is designed to handle up to 3-inch (76,2 mm) diameter spherical solids.

Sealing

Since even a slight leak will affect priming, head, and capacity, especially when operating with a high suction lift, all connections in the suction line should be sealed with pipe dope to ensure an airtight seal. Follow the sealant manufacturer's recommendations when selecting and applying the pipe dope. The pipe dope should be compatible with the liquid being pumped.

Suction Lines In Sumps

If a single suction line is installed in a sump, it should be positioned away from the wall of the

sump at a distance equal to 1 1/2 times the diameter of the suction line.

If there is a liquid flow from an open pipe into the sump, the flow should be kept away from the suction inlet because the inflow will carry air down into the sump, and air entering the suction line will reduce pump efficiency.

If it is necessary to position inflow close to the suction inlet, install a baffle between the inflow and the suction inlet at a distance 1-1/2 times the diameter of the suction pipe. The baffle will allow entrained air to escape from the liquid before it is drawn into the suction inlet.

If two suction lines are installed in a single sump, the flow paths may interact, reducing the efficiency of one or both pumps. To avoid this, position the suction inlets so that they are separated by a distance equal to at least 3 times the diameter of the suction pipe.

Suction Line Positioning

The depth of submergence of the suction line is critical to efficient pump operation. Figure 2 shows recommended minimum submergence vs. velocity.

NOTE

The pipe submergence required may be reduced by installing a standard pipe increaser fitting at the end of the suction line. The larger opening size will reduce the inlet velocity. Calculate the required submergence using the following formula based on the increased opening size (area or diameter).

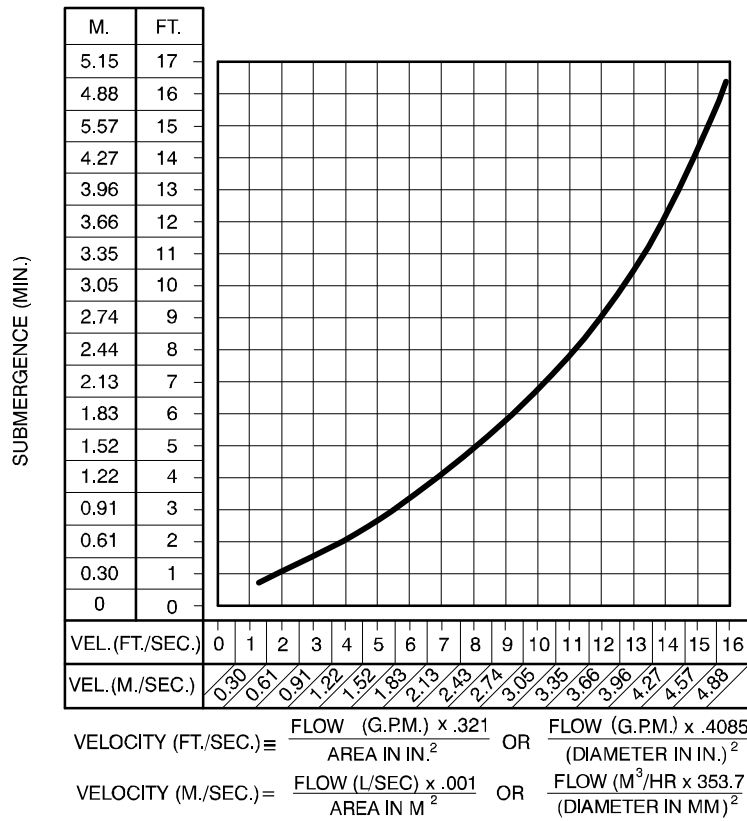

Figure 2. Recommended Minimum Suction Line Submergence vs. Velocity

FLOAT SWITCHES

Installation

The standard pump is equipped with an auto-start control system, and can be conformed to start and stop as the liquid level in the wet well or sump rises and falls. The autostart unit employs either a single or double float switch system, where a bulb raises or lowers (floats) with the liquid level, thus activating an enclosed miniature switch. The floats are equipped with a socket type connector that plugs into a matching receptacle on the auto-start control box.

Standard floats are equipped with 50 feet (15,2 m) of cable.

When installing the floats, note the following:

- a. **Be sure** to provide sufficient room in the wet well or sump so that floats do not get obstructed or drawn into the suction line. If a flexible suction hose is used, it may be extended to lay along the bottom of the wet well or sump and the float can be attached to the hose

above the point where it bends along the bottom. Direct the suction line toward the flow, and the float(s) away from the flow. If a standpipe is available, attach the float switch cable to the standpipe in the sump at the approximate desired liquid level.

- b. In a single float system, the cable can be tethered to the suction line or standpipe approximately 6 inches (152 mm) above the float. This setting allows approximately 9 inches (229 mm) of liquid rise between pump start/stop. The start/stop interval may be increased by extending the float end of the cable. The liquid level in the sump will increase approximately 8 inches (203 mm) between start/stop intervals for every 6 inches (152 mm) of cable increase.
- c. If a double float switch system is used, position the “Start” float at the desired high water level in the sump, and the “Stop” float at the desired low water level in the pump.
- d. Refer to Figure 3 for additional float switch data.

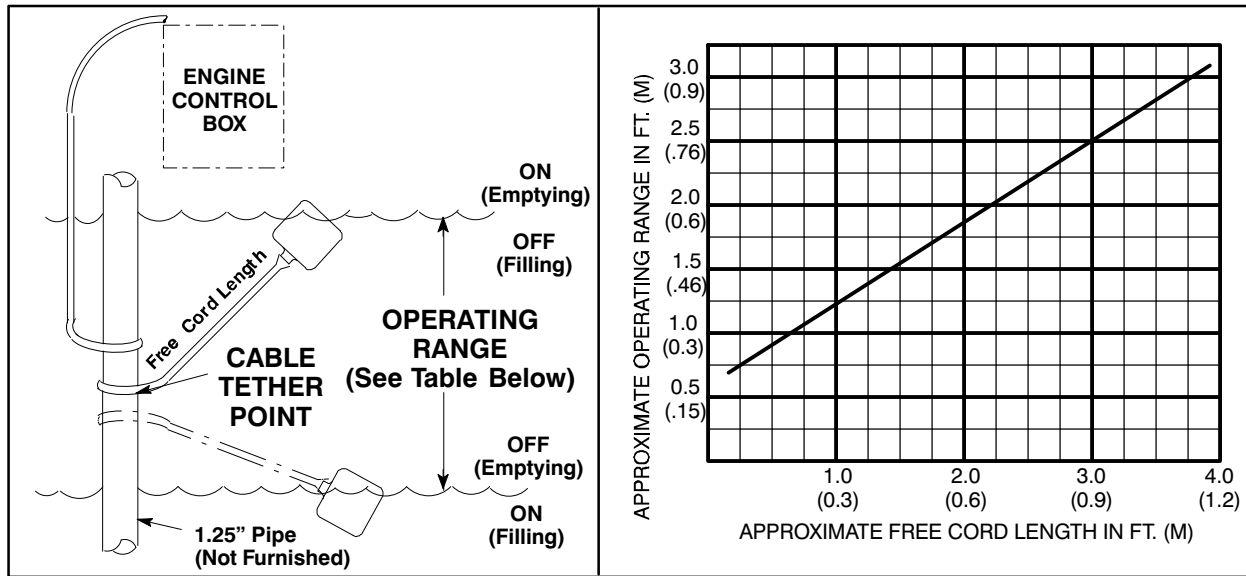

Figure 3. Float Switch Data

OPTIONAL SUBMERSIBLE TRANSDUCER

This unit may be equipped with an optional Electronic Pressure Switch (EPS) that works in conjunction with a submersible transducer. The submersible transducer converts pressure to an electrical signal proportional to liquid level. This electrical signal is distributed to the digital display on the EPS through a scaling circuit which converts the electrical signal to “feet of water”.

When installing the submersible transducer, note the following:

- a. Handle the signal cable and transducer with care during installation. **Carefully** lower the transducer into the wet well or sump; **do not** drop it to the bottom. To avoid clogging, suspend the transducer off the bottom.
- b. **Be sure** to provide sufficient room in the wet well or sump so that the transducer does not get drawn into the suction line. To prevent this, a flexible suction hose may be extended to lay along the bottom of the wet well or sump. The transducer can then be attached to the hose

above the point where it bends along the bottom. See Figure B-4 for a typical installation.

- c. The wet well or sump must be vented to atmosphere.
- d. The EPS is scaled in feet of water column. If the measured medium is other than 1.0 specific gravity, the reading on the EPS should be divided by the specific gravity of the measured medium to obtain the actual level.
- e. **Thoroughly** clean the transducer after each use to prevent clogging.



Do not disassemble the transducer or loosen the compression nut at the signal cable entry. **This will void warranty.** There are no user-serviceable parts inside. Do not nick or cut the jacket of the signal cable; this will cause leakage and **void warranty.**

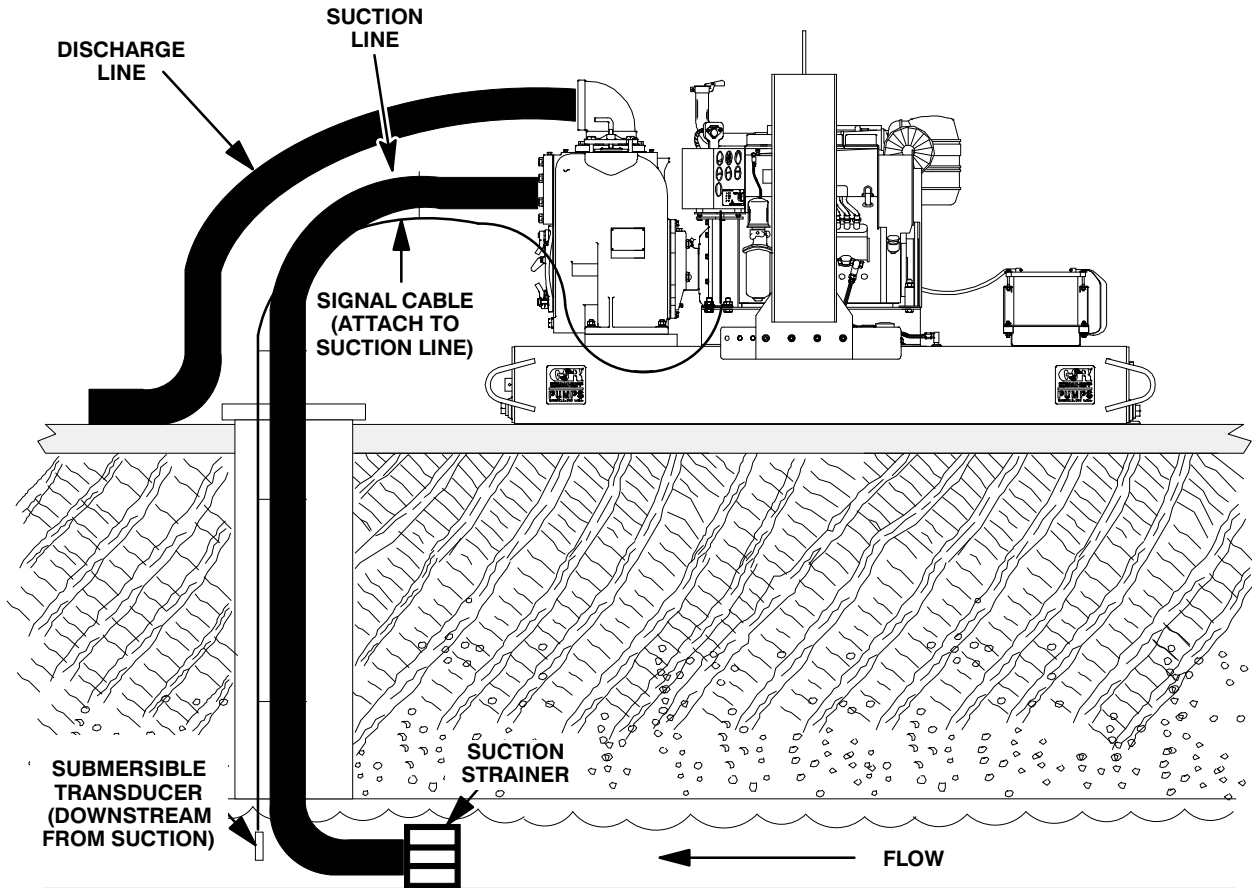

Figure 4. Typical Submersible Transducer Installation

DISCHARGE LINES

Siphoning

Do not terminate the discharge line at a level lower than that of the liquid being pumped unless a siphon breaker is used in the line. Otherwise, a siphoning action causing damage to the pump could result.

Valves

If a throttling valve is desired in the discharge line, use a valve as large as the largest pipe to minimize friction losses. Never install a throttling valve in a suction line.

With high discharge heads, it is recommended that a throttling valve and a system check valve be installed in the discharge line to protect the pump from excessive shock pressure and reverse rotation when it is stopped.

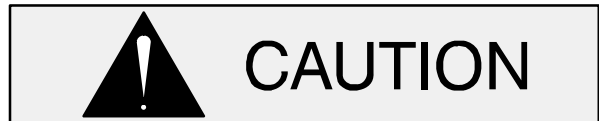

If the application involves a high discharge head, gradually close the discharge throttling valve before stopping the pump.

Bypass Lines

Self-priming pumps are not air compressors. During the priming cycle, air from the suction line must be vented to atmosphere on the discharge side. If the discharge line is open, this air will be vented through the discharge. However, if a check valve has been installed in the discharge line, the discharge side of the pump must be opened to atmospheric pressure through a bypass line installed between the pump discharge and the check valve. A self-priming centrifugal pump **will not prime** if there is sufficient static liquid head to hold the discharge check valve closed.

NOTE

The bypass line should be sized so that it does not

affect pump discharge capacity; however, the bypass line should be at least 1 inch (25,4 mm) in diameter to minimize the chance of plugging.

In **low discharge head applications** (less than 30 feet (9,1 m)), it is recommended that the bypass line be run back to the wet well, and located 6 inches below the water level or cut-off point of the low level pump. In some installations, this bypass outline may be terminated with a six-to-eight foot (1,8 to 2,4 m) length of 1-1/4 inch (31,8 mm) I.D. **smooth-bore** hose; air and liquid vented during the priming process will then agitate the hose and break up any solids, grease, or other substances likely to cause clogging.

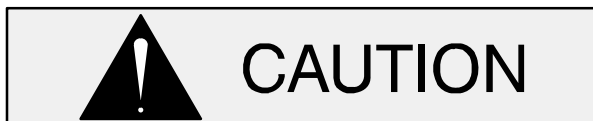

A bypass line that is returned to a wet well must be secured against being drawn into the pump suction inlet.

It is also recommended that pipe unions be installed at each 90° elbow in a bypass line to ease disassembly and maintenance.

In **high discharge head applications** (more than 30 feet (9,1 m)), an excessive amount of liquid may be bypassed and forced back to the wet well under the full working pressure of the pump; this will reduce overall pumping efficiency. **Therefore, it is recommended that a Gorman-Rupp Automatic Air Release Valve be installed in the bypass line.**

Gorman-Rupp Automatic Air Release Valves are reliable, and require minimum maintenance. See **Automatic Air Release Valves** in this section for installation and theory of operation of the Automatic Air Release Valve. Consult your Gorman-Rupp distributor, or contact the Gorman-Rupp Company for selection of an Automatic Air Release Valve to fit your application.



Except in certain specific applications (to prevent flooding during service of an automatic air release valve in a below-ground lift station), if a manual shut-off valve is in-

stalled **anywhere** in a bypass line, it **must** be a full-opening, **ball-type** valve to prevent plugging by solids.



A manual shut-off valve should not be installed in any bypass line. A manual shut-off valve may inadvertently be left closed during operation. A pump which has lost prime may continue to operate without reaching prime, causing dangerous overheating and possible explosive rupture of the pump casing. Personnel could be severely injured.

Allow an over-heated pump to cool before servicing. Do not remove plates, covers, gauges, or fittings from an over-heated pump. Liquid within the pump can reach boiling temperatures, and vapor pressure within the pump can cause parts being disengaged to be ejected with great force. After the pump cools, drain the liquid from the pump by removing the casing drain plug. Use caution when removing the plug to prevent injury to personnel from hot liquid.

AUTOMATIC AIR RELEASE VALVE

When properly installed, a Gorman-Rupp Automatic Air Release Valve will permit air to escape through the bypass line and then close automatically when the pump is fully primed and pumping at full capacity.



Some leakage (1 to 5 gallons [3.8 to 19 liters] per minute) will occur when the valve is fully closed. Be sure the bypass line is directed back to the wet well or tank to prevent hazardous spills.

Consult the manual accompanying the Air Release Valve for additional information on valve installation and performance.

Air Release Valve Installation

The Automatic Air Release Valve must be independently mounted in a horizontal position be-

tween the pump discharge port and the inlet side of the discharge check valve (see Figure 5). The inlet opening in the Air Release Valve is equipped with standard 1-inch NPT pipe threads.

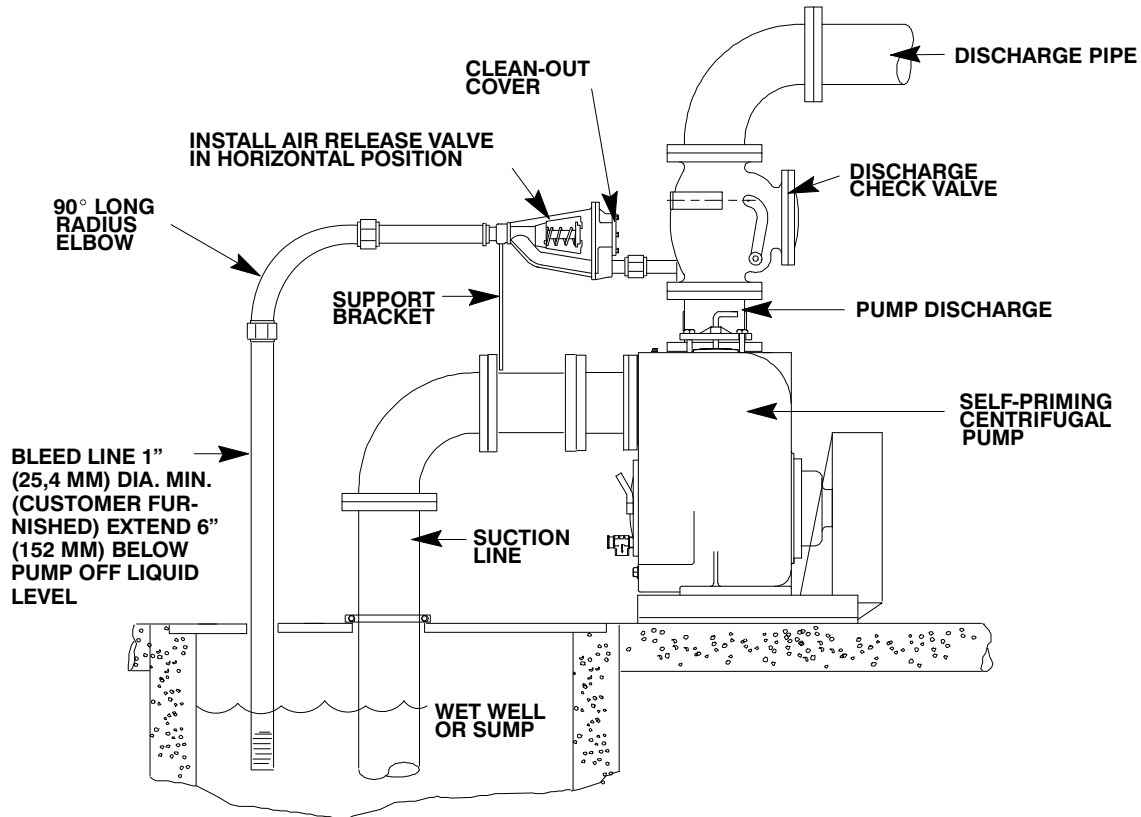

Figure 4. Typical Automatic Air Release Valve Installation

Connect the valve outlet to a bleed line which slopes back to the wet well or sump. The bleed line must be the same size as the outlet opening or larger, depending on which Air Release Valve is being used. If **pipng** is used for the bleed line, avoid the use of elbows whenever possible.

fold pipe. Contact your Gorman-Rupp distributor or the Gorman-Rupp Company for information about installation of an Automatic Air Release Valve for your specific application.

NOTE

*For multiple pump installations, it is recommended that each Air Release Valve be fitted with an independent bleeder line directed back to the wet well. If multiple Air Release Valves are installed in a system, **do not** direct bleeder lines to a common mani-*

ALIGNMENT

The alignment of the pump and the engine is critical for trouble-free mechanical operation. See Section E, **Securing Intermediate And Drive Assembly To Engine** for detailed information.

OPERATION – SECTION C

Review all **SAFETY** information in Section A.

Follow the instructions on all tags, labels and decals attached to the pump.



Do not operate an internal combustion engine in an explosive atmosphere. When operating internal combustion engines in an enclosed area, make certain that exhaust fumes are piped to the outside. These fumes contain carbon monoxide, a deadly gas that is colorless, tasteless, and odorless.



This pump is designed to handle dirty water containing specified entrained solids and slurries. Do not attempt to pump volatile, corrosive, or flammable liquids which may damage the pump or endanger personnel as a result of pump failure.



Never tamper with the governor to gain more power. The governor establishes safe operating limits that should not be exceeded. The maximum continuous operating speed for this pump is 1450 RPM.

PRIMING

Install the pump and piping as described in **INSTALLATION**. Make sure that the piping connections are tight, and that the pump is securely mounted. Check that the pump is properly lubri-

cated (see **LUBRICATION** in **MAINTENANCE AND REPAIR**).

This pump is self-priming, but the pump should never be operated unless there is liquid in the pump casing.



Never operate this pump unless there is liquid in the pump casing. The pump will not prime when dry. Extended operation of a dry pump will destroy the seal assembly.

Add liquid to the pump casing when:

1. The pump is being put into service for the first time.
2. The pump has not been used for a considerable length of time.
3. The liquid in the pump casing has evaporated.

Once the pump casing has been filled, the pump will prime and reprime as necessary.



After filling the pump casing, reinstall and tighten the fill plug. Do not attempt to operate the pump unless all connecting piping is securely installed. Otherwise, liquid in the pump forced out under pressure could cause injury to personnel.

To fill the pump, remove the pump casing fill cover or fill plug in the top of the casing, and add clean liquid until the casing is filled. Replace the fill cover or fill plug before operating the pump.

NOTE

If the suction or discharge piping is open, a hose can be used to fill the casing through the piping.

STARTING



This pump is equipped with an automatic starting system, and is subject to automatic restart. Keep hands and clothing away from the unit to prevent injury during automatic operation. Disconnect the positive battery cable before performing any maintenance. Failure to do so may result in serious personal injury.

Consult the operations manual furnished with the engine.

Manual Starting

On initial start-up, set the engine speed at the half-throttle position. Turn the keyswitch on the control panel to the "RUN" and press "ENTER" button on the engine control panel.

After the engine starts and the unit is fully primed, adjust the engine RPM until the desired flow rate is achieved.



Pump speed and operating condition points must be within the continuous performance range shown on the curve on page E-1.

Automatic Starting

Install the float(s) or submersible transducer as described in **INSTALLATION, Section B**.

Follow the procedures outlined for manual starting and throttle adjustment, then turn the key to the "AUTO" position.

In the auto-start mode, when the liquid level in the sump or wet well rises and activates the float(s), an audible alarm will sound for approximately 8 seconds before the unit starts.

When the liquid level in the sump or wet well is sufficiently pumped down, the unit will automatically shut down.

NOTE

If the keyswitch is moved to the "OFF" position while in the auto-start mode, the engine will stop. However, the auto-start process will continue as soon as the keyswitch is moved back to the "AUTO" position. To cancel the auto-start process, turn the keyswitch to the "OFF" position for 8 seconds..

The control panel is equipped with high oil temperature, low oil pressure, and start failure (3 attempts) safety shutdowns. If any of these problems occur, the control panel will indicate the fault. When the problem is corrected, turn the keyswitch to the "OFF" position to reset the control.

OPTIONAL EPS CONTROL

Features

The optional EPS Control is equipped with a 12VDC Electronic Pressure Switch which includes the following features:

- 3 Output Relays:
 1. A output, delayed
 2. B output, no delay
 3. Horn output, no delay
- 3 Inputs:
 1. Horn silence
 2. Pressure transducer
 3. Low Temp Thermostat
- LCD screen with backlight for function monitoring
- Bright LEDs to indicate output status and display modes
- Three switches on front panel for **all** adjustments
- Battery level indicator on LCD screen to alert operator of low battery condition
- Microprocessor Control
- Error display to alert user of errors in calibration

Functional Description

Front Panel Controls/Displays

1. The LCD screen displays level information, A and B setpoint off/on levels, Horn delay,

and calibration information.

Typical Messages on the display:

- a) EEP bAd... Eeprom memory is not correct, user **must** recalibrate unit.
- b) USr CAL... User calibrate mode, i.e., user **wants** to calibrate unit.
- c) SEt a.oF... A OFF setpoint, units of level.
- d) SEt a.on... A ON setpoint, units of level.
- e) SEt b.oF... B OFF setpoint, units of level.
- f) SEt b.on... B ON setpoint, units of level.
- g) Hrn dLy... Horn on, A output delay time, 5–30 seconds, in 5-second increments.
- h) LO BAT... Indicator, shows battery voltage level is below 12VDC.
- i) Lo tpt... Shows status of Low Temperature Thermostat contacts.



2. LEDs:

- a) When the green LED is lighted, the unit is showing level on the LCD display.
- b) When the A output LED is lighted, the A output relay is closed.
- c) When the B output LED is lighted, the B output relay is closed

NOTE

LED's and all segments of the display are lighted upon connection of power as a lamp test feature. However, no relay outputs are closed during test.

3. Switches:

- a) The  switch functions as a “round robin” type switch. Pressing this switch will cause the unit to show the next selection in the order listed above.
- b) The  switch functions to decrease the selection showing. This switch can be

used to decrease the smallest digit by “bumping” the switch, or to continuously decrease the digit by pressing and holding for at least one second and releasing when desired setting is reached.

- c. The  switch functions to increase the selection showing. This switch can be used to increase the smallest digit by “bumping” the switch, or to continuously increase the digit by pressing and holding for at least one second and releasing when desired setting is reached.

Liquid level adjustment of the Electronic Pressure Switch is accomplished using the three buttons on the control. For EPS functions and level adjustment, refer to the following instructions.

EPS Functions

Actual functions of the control occur as follows:

Power is applied to the unit.

Unit performs display test for approximately 4 seconds.

When the pressure level showing is equal to or greater than the “A.on” setpoint, the Horn output contacts will close in approximately 1 second and a delay, equal to the “Hrn dLy” time, will occur before the A output contacts close.

When the level showing is equal to or greater than the “B.on” setpoint, the B output contacts will close in approximately 1 second.

When the pressure decreases to a level equal to or less than the “B.of” setpoint, B output contacts will open in approximately one second.

When the pressure decreases to a level equal to or less than the “A.of” setpoint, A output contacts will open in approximately one second.

If an optional Low Temperature Thermostat is connected to the unit and the thermostat contacts close, the unit displays “lo tpt” on the display. In approximately 1 second, the Horn output contacts close, then after the “Hrn dLy” time, A output contacts close. A output contacts will remain closed as long as Low Temperature Thermostat contacts are closed.

When the Low Temperature Contacts open, A output contact will open **only** if the level is equal to or less than the “A.off” setpoint.

As long as the Low Temperature Thermostat contacts are closed, the display will show “lo tpt” unless  switch is pressed to display some other information. Level is not viewable until the Low Temperature Thermostat contacts open.

The user may wish to check Setpoints Off/On delay times. “Bumping” the  switch will display all of the information desired.

NOTE

One second delays in contact opening/closing is a result of time sampling of the pressure signal to filter false signals that could cause “nuisance” tripping of the contacts.

NOTE

If the “Hrn dLy” is pre-set from the factory through the engine control panel, therefore this function is not utilized through the EPS.



Use caution to ensure that the “--.on” setpoint (i.e. “A.on”) is not adjusted to a level less than the corresponding “--.of” setpoint (i.e. “A.of”). Improper adjustment of the off/on setpoints will render the unit non-functional, resulting in flooding.

EPS Calibration

NOTE



Zero offset and span adjustments are only necessary to calibrate a new unit, or when replacing the transducer. Once calibrated, “ON” and “OFF” setpoints will be stored in the unit’s memory. Liquid level adjustments will be used whenever “ON” and “OFF” liquid levels must be reset.

There are two reasons for the user to calibrate the unit. When power is applied, the unit confirms setpoints and other calibration information for validity. If the setpoints are not valid, the LCD screen shows “EEP bAd” and the unit must be recalibrated. Also,

if the unit is moved, or some other external change takes place, the unit must be recalibrated.

Zero Adjustment



Zero adjustment tells the unit when the transducer is exposed to zero water (atmospheric) pressure. When recalibration is desired, hold the transducer in hand and apply power to the unit. The LCD screen will display “Level ABC”. Press and hold  for 5 seconds. The LCD screen displays “Input? External XDU CR”. Perform the following calibration procedures.

Press  3 times and the LCD screen will display “Calibrate Zro”. Press  or  until a character or number on the display changes.

Press  to accept the entry and advance to “Calibrate Span”.







Span Adjustment

Span adjustment calibrates the unit to a known water pressure (depth). To set:

Submerge the transducer to an exact known depth. At “Calibrate Span”, the span setting in the unit’s memory will display. Press  to increase or  to decrease the value until the LCD screen display equals the actual known depth of the transducer.

Level Adjustment

Level adjustment tells the unit when to turn the pump on and off. To set:

From “Level ABC” display, press  once and “Pump Setpt A On” will display. Press  to increase or  to decrease to the desired level at which the pump turns on. Press  to advance to “Pump Setpt A Off”. Press  to increase or  to decrease to the desired level at which the pump turns off.

Press  again to advance to “Pump Setpt B On”. If “B” is to be used, repeat the procedure described above for adjusting level “A”.

Horn Delay

The horn delay is pre-set from the factory through the engine control panel, therefore this function is not utilized through the EPS.

OPERATION

A Gorman-Rupp automatic air release valve may be installed in a bypass line, or the bypass line may be left open.



A manual shut-off valve should not be installed in any bypass line. A manual shut-off valve may inadvertently be left closed during operation. A pump which has lost prime may continue to operate without reaching prime, causing dangerous overheating and possible explosive rupture of the pump casing. Personnel could be severely injured.

Lines With a Bypass

If a Gorman-Rupp Automatic Air Release Valve has been installed, the valve will automatically open to allow the pump to prime, and automatically close after priming is complete (see **INSTALLATION** for Air Release Valve operation).

If the bypass line is open, air from the suction line will be discharged through the bypass line back to the wet well during the priming cycle. Liquid will then continue to circulate through the bypass line while the pump is in operation.

Lines Without a Bypass

Open all valves in the discharge line and start the engine. Priming is indicated by a positive reading on the discharge pressure gauge or by a quieter operation. The pump may not prime immediately because the suction line must first fill with liquid. If the pump fails to prime within five minutes, stop it and check the suction line for leaks.

After the pump has been primed, partially close the discharge line throttling valve in order to fill the line

slowly and guard against excessive shock pressure which could damage pipe ends, gaskets, sprinkler heads, and any other fixtures connected to the line. When the discharge line is completely filled, adjust the throttling valve to the required flow rate.

Leakage

No leakage should be visible at pump mating surfaces, or at pump connections or fittings. Keep all line connections and fittings tight to maintain maximum pump efficiency.

Liquid Temperature And Overheating

The **maximum** liquid temperature for this pump is 160° F (71° C). Do not apply it at a higher operating temperature.

Overheating can occur if operated with the valves in the suction or discharge lines closed. Operating against closed valves could bring the liquid to a boil, build pressure, and cause the pump to rupture or explode. If overheating occurs, stop the pump and allow it to cool before servicing it. Refill the pump casing with cool liquid.



Allow an over-heated pump to cool before servicing. Do not remove plates, covers, gauges, or fittings from an over-heated pump. Liquid within the pump can reach boiling temperatures, and vapor pressure within the pump can cause parts being disengaged to be ejected with great force. After the pump cools, drain the liquid from the pump by removing the casing drain plug. Use caution when removing the plug to prevent injury to personnel from hot liquid.

As a safeguard against rupture or explosion due to heat, this pump is equipped with a pressure relief valve which will open if vapor pressure within the pump casing reaches a critical point. If overheating does occur, stop the pump immediately and allow it to cool before servicing it. **Approach any over-heated pump cautiously.** It is recommended that the pressure relief valve assembly be

replaced at each overhaul, or any time the pump casing over-heats and activates the valve. **Never** replace this valve with a substitute which has not been specified or provided by the Gorman-Rupp Company.

Strainer Check

If a suction strainer has been shipped with the pump or installed by the user, check the strainer regularly, and clean it as necessary. The strainer should also be checked if pump flow rate begins to drop. If a vacuum suction gauge has been installed, monitor and record the readings regularly to detect strainer blockage.

Never introduce air or steam pressure into the pump casing or piping to remove a blockage. This could result in personal injury or damage to the equipment. If backflushing is absolutely necessary, **liquid pressure** must be limited to 50% of the maximum permissible operating pressure shown on the pump performance curve.

Pump Vacuum Check

With the pump inoperative, install a vacuum gauge in the system, using pipe dope on the threads. Block the suction line and start the pump. At operating speed the pump should pull a vacuum of 20 inches (508 mm) or more of mercury. If it does not, check for air leaks in the seal, gasket, or discharge valve.

Open the suction line, and read the vacuum gauge with the pump primed and at operation speed. Shut off the pump. The vacuum gauge reading will immediately drop proportionate to static suction lift, and should then stabilize. If the vacuum reading falls off rapidly after stabilization, an air leak exists. Before checking for the source of the leak, check the point of installation of the vacuum gauge.

STOPPING

Manual Stopping

In the manual mode, reduce the throttle speed slowly, and allow the engine to idle briefly before turning the keyswitch to 'OFF'.



If the application involves a high discharge head, gradually close the discharge throttling valve before stopping the pump.

After stopping the pump, close and lock the control panel cover, or disconnect the positive battery cable to ensure that the pump will remain inoperative.

Automatic Stopping

In the automatic mode, the pump will stop when the liquid in the wet well or sump lowers and activates the "Off" float switch(s) or "Off" setpoint stored in the optional EPS. The pump will restart automatically when the liquid rises and activates the "On" float switch(s) or "On" setpoint stored in the optional EPS.

Safety Shutdown System

The unit is equipped with a safety system to automatically shut down the engine under certain conditions. The engine will automatically shut down:

1. If the engine exceeds its safe operating temperature.
2. If the engine oil pressure drops below design limits.
3. If the engine fails to start within a pre-set period of time.
4. If the engine speed exceeds the safe operating range.

Lights on the control panel will indicate which of the safety features has caused the engine to shut down.

Should any of the safety features cause the engine to shut down, **the cause must be determined and corrected** before putting the unit back into service. The engine **will not restart** until the keyswitch has been returned to the 'OFF' position for at least 10 seconds.

All safety shutdown features are pre-set at the factory for optimum performance and safety; **do not** attempt to adjust these settings.



Never disconnect any of the safety shutdown features; this will void the warranty and could result in serious damage to the unit and/or injury to personnel. Safety shutdown features are pre-set at the factory; do not attempt to adjust any of the settings. Determine the cause of shutdown before putting the unit back into service. Consult the factory for additional information.

OPERATION IN EXTREME HEAT

The safety shutdown system will automatically stop the unit if engine operating temperature exceeds design limits. If engine over-temperature shutdown occurs, allow the unit to cool before re-starting.

If engine overheating continues, check the engine lubricant level and viscosity. Consult the engine operation manual for the recommended lubricant for operation in extreme heat.

If the unit is equipped with the optional auto-start control, the float(s) may need to be adjusted to allow shorter run and longer cooling periods, if possible.



This pump is equipped with an automatic starting system, and is subject to automatic restart. Keep hands and clothing away from the unit to prevent injury during automatic operation. Disconnect the positive battery cable before performing any maintenance. Failure to do so may result in serious personal injury.

Cold Weather Preservation

In below freezing conditions, drain the pump to prevent damage from freezing. Also, clean out any solids by flushing with a hose. Operate the pump for approximately one minute; this will remove any remaining liquid that could freeze the pump rotating parts. If the pump will be idle for more than a few hours, or if it has been pumping liquids containing a large amount of solids, drain the pump, and flush it thoroughly with clean water. To prevent large solids from clogging the drain port and preventing the pump from completely draining, insert a rod or stiff wire in the drain port, and agitate the liquid during the draining process. Clean out any remaining solids by flushing with a hose.

BEARING TEMPERATURE CHECK

Bearings normally run at higher than ambient temperatures because of heat generated by friction. Temperatures up to 160°F (71°C) are considered normal for bearings, and they can operate safely to at least 180°F (82°C).

Checking bearing temperatures by hand is inaccurate. Bearing temperatures can be measured accurately by placing a contact-type thermometer against the housing. Record this temperature for future reference.

A sudden increase in bearing temperatures is a warning that the bearings are at the point of failing to operate properly. Make certain that the bearing lubricant is of the proper viscosity and at the correct level (see **LUBRICATION** in Section E). Bearing overheating can also be caused by shaft misalignment and/or excessive vibration.

When pumps are first started, the bearings may seem to run at temperatures above normal. Continued operation should bring the temperatures down to normal levels.

TROUBLESHOOTING – SECTION D

Review all SAFETY information in Section A.



Before attempting to open or service the pump:

1. Familiarize yourself with this manual.
2. Shut down the engine and disconnect the positive battery cable to ensure that the pump will remain inoperative.
3. Allow the pump to completely cool if overheated.
4. Check the temperature before opening any covers, plates, or plugs.

5. Close the suction and discharge valves.
6. Vent the pump slowly and cautiously.
7. Drain the pump.



This pump is equipped with an automatic starting system, and is subject to automatic restart. Keep hands and clothing away from the unit to prevent injury during automatic operation. Disconnect the positive battery cable before performing any maintenance. Failure to do so may result in serious personal injury.

Table 1. Trouble Shooting Chart

TROUBLE	POSSIBLE CAUSE	PROBABLE REMEDY
PUMP FAILS TO PRIME	Not enough liquid in casing.	Add liquid to casing. See PRIMING .
	Suction check valve contaminated or damaged.	Clean or replace check valve.
	Air leak in suction line.	Correct leak.
	Lining of suction hose collapsed.	Replace suction hose.
	Leaking or worn seal or pump gasket.	Check pump vacuum. Replace leaking or worn seal or gasket.
	Suction lift or discharge head too high.	Check piping installation and install bypass line if needed. See INSTALLATION .
PUMP STOPS OR FAILS TO DELIVER RATED FLOW OR PRESSURE	Strainer clogged.	Check strainer and clean if necessary.
	Air leak in suction line.	Correct leak.
	Lining of suction hose collapsed.	Replace suction hose.

Table 1. Trouble Shooting Chart (cont.)

TROUBLE	POSSIBLE CAUSE	PROBABLE REMEDY
PUMP STOPS OR FAILS TO DELIVER RATED FLOW OR PRESSURE (cont.)	Leaking or worn seal or pump gasket.	Check pump vacuum. Replace leaking or worn seal or gasket.
	Strainer clogged.	Check strainer and clean if necessary.
	Suction intake not submerged at proper level or sump too small.	Check installation and correct submergence as needed.
	Impeller or other wearing parts worn or damaged.	Replace worn or damaged parts. Check that impeller is properly centered and rotates freely.
	Impeller clogged.	Free impeller of debris.
	Discharge head too high.	Install bypass line.
	Suction lift too high.	Measure lift w/vacuum gauge. Reduce lift and/or friction losses in suction line.
PUMP REQUIRES TOO MUCH POWER	Pump speed too slow.	Check engine output; consult engine operation manual.
	EPS limit switches set improperly or submersible transducer clogged.	Check EPS limit settings; check and clean submersible transducer.
	Pump speed too high.	Check engine output.
	Discharge head too low.	Adjust discharge valve.
PUMP CLOGS FREQUENTLY	Liquid solution too thick.	Dilute if possible.
	Bearing(s) frozen.	Disassemble pump and check bearing(s).
	Discharge flow too slow.	Open discharge valve fully to increase flow rate, and run engine at maximum governed speed.
EXCESSIVE NOISE	Suction check valve or foot valve clogged or binding.	Clean valve.
	Liquid solution too thick.	Dilute if possible.
	Cavitation in pump.	Reduce suction lift and/or friction losses in suction line. Record vacuum and pressure gauge readings and consult local representative or factory.
	Pumping entrained air.	Locate and eliminate source of air bubble.
	Pump or drive not securely mounted.	Secure mounting hardware.
	Impeller clogged or damaged.	Clean out debris; replace damaged parts.

Table 1. Trouble Shooting Chart (cont.)

TROUBLE	POSSIBLE CAUSE	PROBABLE REMEDY
BEARINGS RUN TOO HOT	Bearing temperature is high, but within limits.	Check bearing temperature regularly to monitor any increase.
	Low or incorrect lubricant.	Check for proper type and level of lubricant.
	Suction and discharge lines not properly supported.	Check piping installation for proper support.
	Drive misaligned.	Align drive properly.

PREVENTIVE MAINTENANCE

Since pump applications are seldom identical, and pump wear is directly affected by such things as the abrasive qualities, pressure and temperature of the liquid being pumped, this section is intended only to provide general recommendations and practices for preventive maintenance. Regardless of the application however, following a routine preventive maintenance schedule will help assure trouble-free performance and long life from your Gorman-Rupp pump. For specific questions concerning your application, contact your Gorman-Rupp distributor or the Gorman-Rupp Company.

Record keeping is an essential component of a good preventive maintenance program. Changes in suction and discharge gauge readings (if so

equipped) between regularly scheduled inspections can indicate problems that can be corrected before system damage or catastrophic failure occurs. The appearance of wearing parts should also be documented at each inspection for comparison as well. Also, if records indicate that a certain part (such as the seal) fails at approximately the same duty cycle, the part can be checked and replaced before failure occurs, reducing unscheduled down time.

For new applications, a first inspection of wearing parts at 250 hours will give insight into the wear rate for your particular application. Subsequent inspections should be performed at the intervals shown on the chart below. Critical applications should be inspected more frequently.

Preventive Maintenance Schedule					
Item	Service Interval*				
	Daily	Weekly	Monthly	Semi-Annually	Annually
General Condition (Temperature, Unusual Noises or Vibrations, Cracks, Leaks, Loose Hardware, Etc.)	I				
Pump Performance (Gauges, Speed, Flow)	I				
Bearing Lubrication		I			R
Seal Lubrication (And Packing Adjustment, If So Equipped)		I			R
V-Belts (If So Equipped)			I		
Air Release Valve Plunger Rod (If So Equipped)			I	C	
Front Impeller Clearance (Wear Plate)				I	
Rear Impeller Clearance (Seal Plate)				I	
Check Valve					I
Pressure Relief Valve (If So Equipped)					C
Pump and Driver Alignment					I
Shaft Deflection					I
Bearings					I
Bearing Housing					I
Piping					I
Driver Lubrication – See Mfgr’s Literature					I

Legend:
 I = Inspect, Clean, Adjust, Repair or Replace as Necessary
 C = Clean
 R = Replace

* Service interval based on an intermittent duty cycle equal to approximately 4000 hours annually. Adjust schedule as required for lower or higher duty cycles or extreme operating conditions.

PUMP MAINTENANCE AND REPAIR - SECTION E

MAINTENANCE AND REPAIR OF THE WEARING PARTS OF THE PUMP WILL MAINTAIN PEAK OPERATING PERFORMANCE.

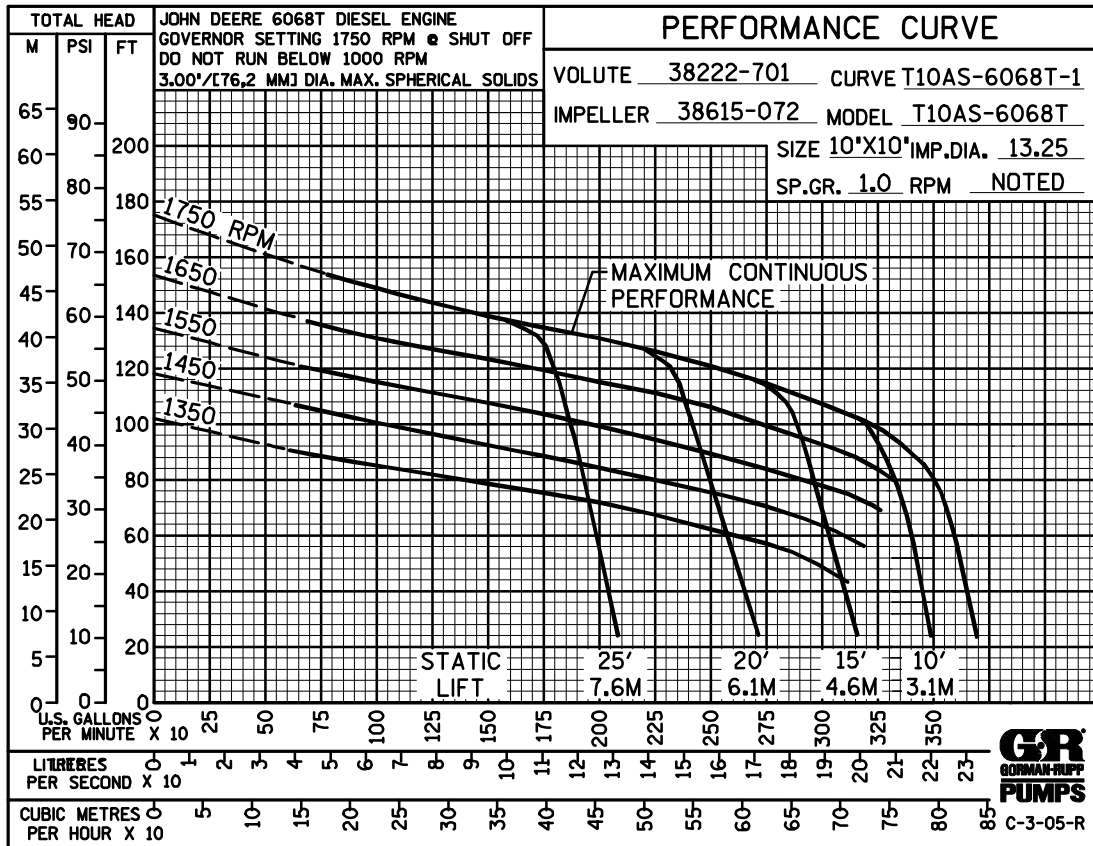

*** STANDARD PERFORMANCE FOR PUMP MODEL T10A65S-6068T**

* Based on 70° F (21° C) clear water at sea level with minimum suction lift. Since pump installations are seldom identical, your performance may be different due to such factors as viscosity, specific gravity, elevation, temperature, and impeller trim.

Contact the Gorman-Rupp Company to verify performance or part numbers.



Pump speed and operating condition points must be within the continuous performance range shown on the curve.

If your pump serial number is followed by an "N", your pump is **NOT** a standard production model.

SECTION DRAWING

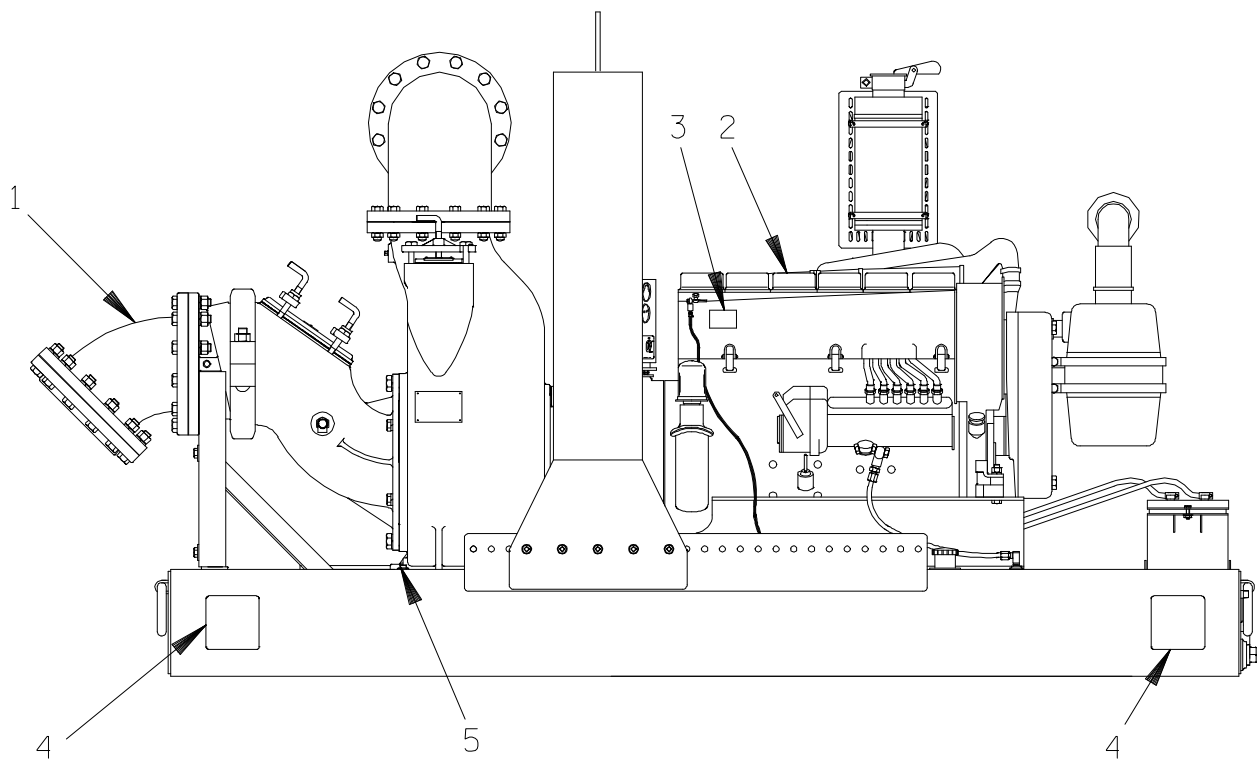

Figure 1. Pump Model T10A65S-6068T

PARTS LIST
Pump Model T10A65S-6068T
 (From S/N 1413937 Up)

If your pump serial number is followed by an "N", your pump is **NOT** a standard production model. Contact the Gorman-Rupp Company to verify part numbers.

ITEM NO.	PART NAME	PART NUMBER	MAT'L CODE	QTY
1	PUMP END ASSY	T10A65S-(SAE 3/11.5)	----	1
2	POWER UNIT KIT	46143-018	----	1
3	1000 RPM MIN DECAL	38816-169	----	1
4	G-R DECAL	GR-06	----	4
5	PUMP MOUNTING KIT	48157-005	----	1
	-SUCTION STAND BRACKET	34455-007	15080	1
	-SUCTION BRACE ASSY	41818-653	24150	1
OPTIONAL:				
	12V BATTERY	29331-515	----	1
	WHEEL KIT	GRP30-257	----	1

* INDICATES PARTS RECOMMENDED FOR STOCK

SECTION DRAWING

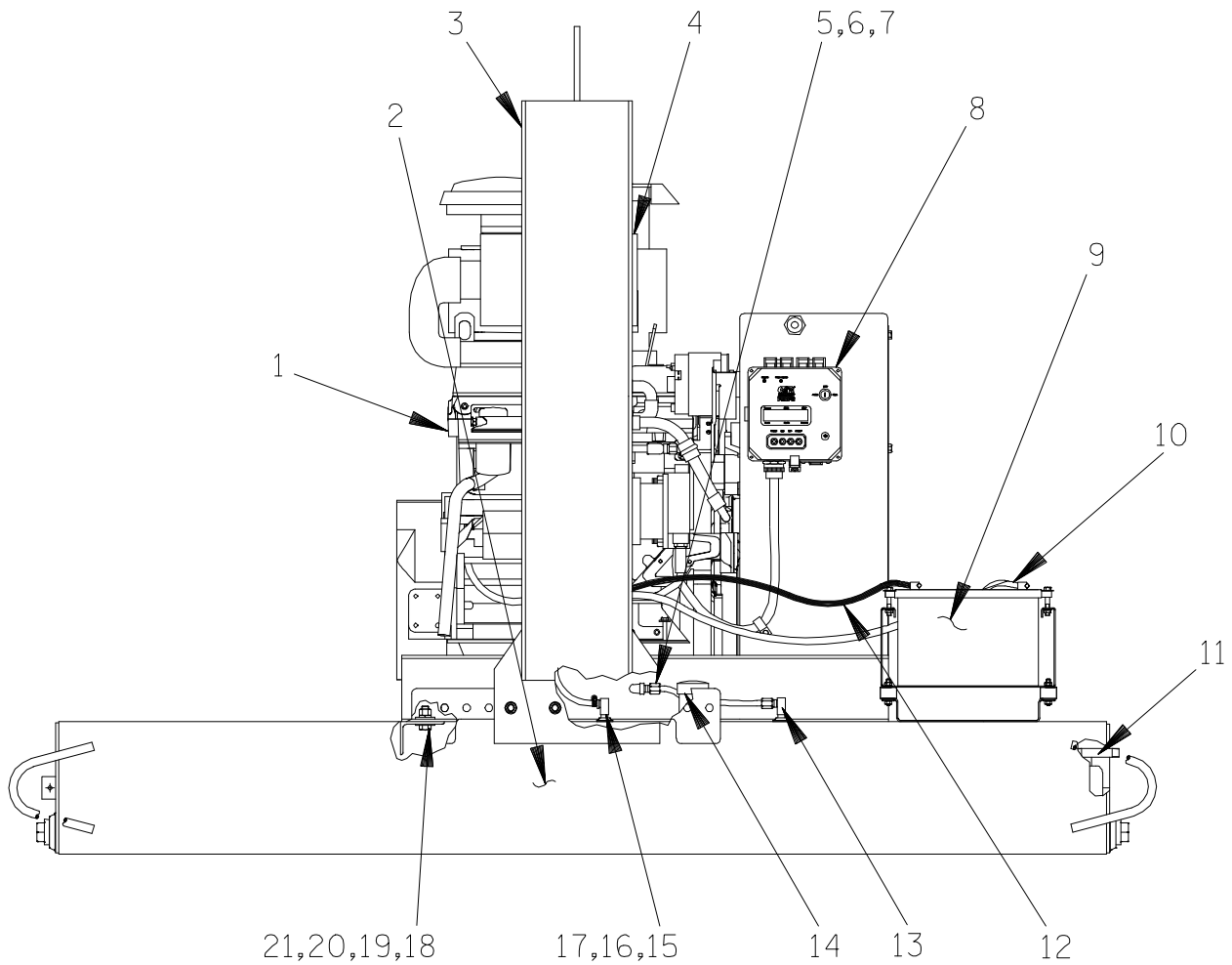

Figure 2. 46143-018 John Deere Power Unit Kit

PARTS LIST
46143-018 John Deere Power Unit Kit

ITEM NO.	PART NAME	PART NUMBER	MAT'L CODE	QTY
1	JOHN DEERE 6068T ENGINE	29224-231	---	1
2	BASE/FUEL TANK	41553-008	24150	1
3	LIFTING BAIL KIT	48274-802	---	1
4	MUFFLER GUARD ASSY	42331-066	---	1
5	MALE CONNECTOR	26351-131	---	1
6	CONNECTOR	S1447	---	2
7	HOSE ASSEMBLY	46341-789	---	1
8	CONTROL PANEL	SUPPLIED W/ENGINE		1
9	BATTERY BOX KIT	42432-003	---	1
10	NEG. BATTERY CABLE	47311-215	---	1
11	OIL DRAIN ASSY	46342-031	---	1
12	POS. BATTERY CABLE	47311-214	---	1
13	FUEL PICKUP	29332-145	---	2
14	FUEL GAUGE	29332-135	---	1
15	HOSE BARB FITTING	26523-386	---	2
16	HOSE	11308G	---	1
17	HOSE CLAMP	26518-641	---	2
18	HEX HD CAPSCREW	B1007	15991	6
19	HEX NUT	D10	15991	6
20	LOCKWASHER	J10	15991	6
21	FLAT WASHER	K10	15991	1
NOT SHOWN:				
	FLOAT SWITCH KIT	48312-980	---	1
	ENGINE STARTUP TAG	38816-269	---	1
	INSTRUCTION DECAL	38818-144	---	1
	WARNING DECAL	38816-203	---	1

* INDICATES PARTS RECOMMENDED FOR STOCK

SECTION DRAWING

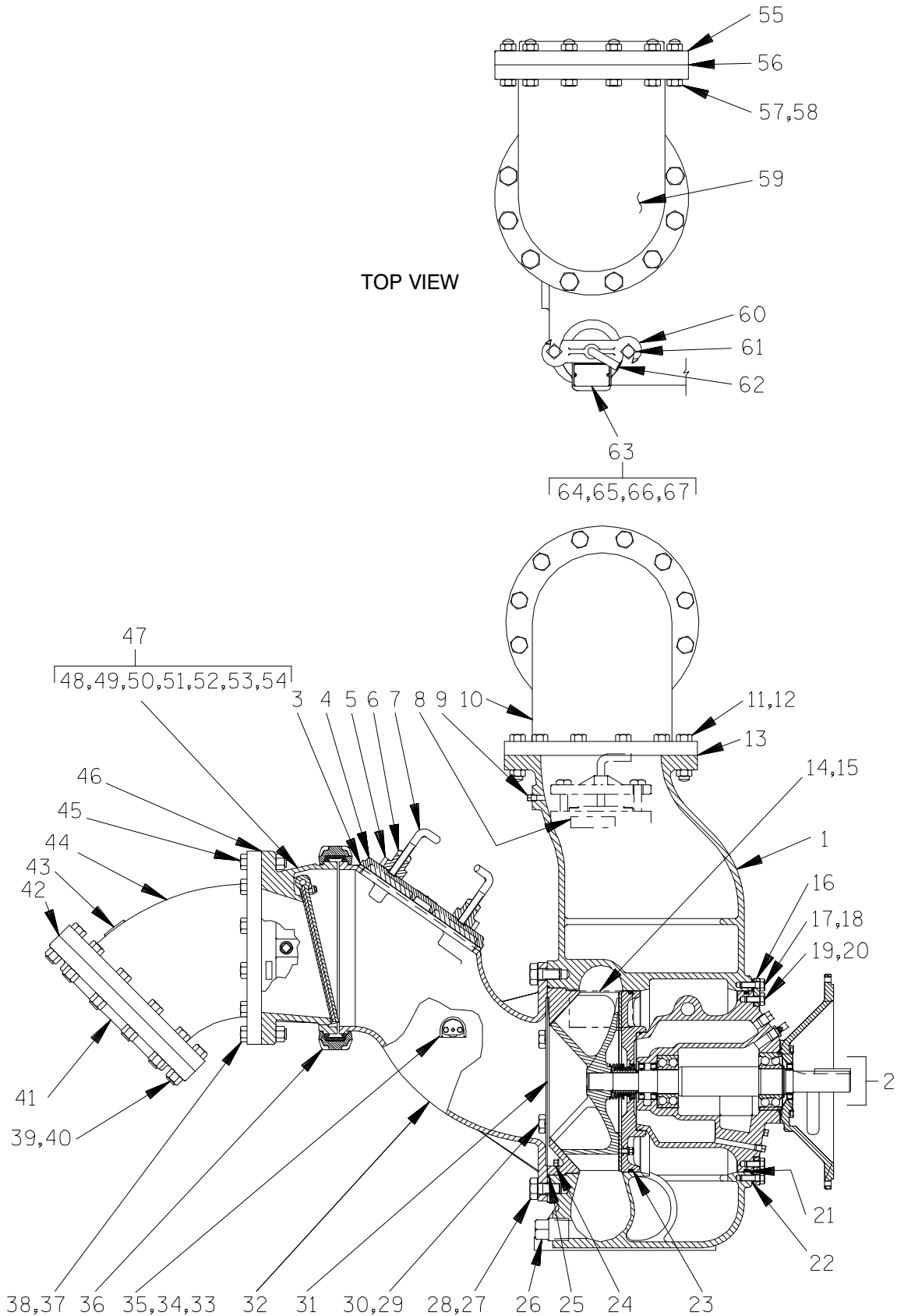

Figure 3. T10A65S—(SAE 3/11.5) Pump End Assembly

PARTS LIST
T10A65S-(SAE 3/11.5) Pump End Assembly

ITEM NO.	PART NAME	PART NUMBER	MAT'L CODE	QTY	ITEM NO.	PART NAME	PART NUMBER	MAT'L CODE	QTY
1	PUMP CASING	38222-701	17180	1	40	HEX NUT	D14	17090	12
2 *	REPAIR ROTATING ASSY	44163-487	----	1	41	SUCTION FLANGE	2751	17040	1
3 *	COVER PLATE GASKET	38688-008	19410	1	42 *	SUCTION GASKET	2751GA	19410	1
4	COVER PLATE ASSY	48271-019	----	1	43	SUCTION STICKER	6588AG	----	1
5	CLAMP BAR	38111-004	17040	2	44	45° SUCTION ELBOW	25530-508	----	1
6	MACHINE BOLT	A1014	17090	4	45	HEX HD CAPSCREW	B1410	17090	2
7	CLAMP BAR SCREW	31912-009	1704G	2	46 *	SUCT ELBOW GASKET	2751GA	19410	1
8	PRIMING STICKER	6588AH	----	1	47	CHECK VALVE ASSY	46421-044	----	1
9	PIPE PLUG	P04	17090	1	48	-HEX HD CAPSCREW	B0606	17090	2
10	DISCHARGE STICKER	6588BJ	----	1	49	-PIPE PLUG	P08	17090	1
11	HEX HD CAPSCREW	B1414	17090	12	50	-T TYPE LOCKWASHER	AK06	17040	2
12	HEX NUT	D14	17090	12	51	-FLAT WASHER	KB08	17090	2
13 *	DISCH ELBOW GASKET	2751GA	19410	1	52	-PIVOT CAP	38141-003	17180	2
14	NAME PLATE	38818-040	17040	1	53	-CHK VALVE BODY	38341-805	17180	1
15	DRIVE SCREW	BM#04-03	17090	4	54 *	-FLAP VALVE	46411-081	24010	1
16	PUMP CASING RING	31281-016	17040	1	55	DISCHARGE FLANGE	2751	17040	1
17	HEX HD CAPSCREW	B0806	17090	6	56 *	DISCH FLG GASKET	2751GA	19410	1
18	LOCKWASHER	J08	17090	6	57	HEX HD CAPSCREW	B1414	17000	12
19	HEX HD CAPSCREW	B0805	17090	6	58	HEX NUT	D14	17090	12
20	LOCKWASHER	J08	17090	6	59	FLANGED ELBOW	25530-337	----	1
21 *	BEARING HSG O-RING	25154-458	----	1	60	CLAMP BAR	38111-004	17040	1
22	ROT ASSY ADJ SHIM SET	48261-056	----	6	61	MACHINE BOLT	A1014	17090	2
23 *	SEAL PLATE O-RING	25154-458	----	1	62	CLAMP BAR SCREW	31912-009	1704G	1
24	PIPE PLUG	P08	17090	1	63	FILL COVER PLATE ASSY	42111-385	----	1
25 *	SUCTION HEAD GASKET	38682-811	19410	1	64	-COVER PLATE	NOT AVAILABLE		1
26	CASING DRAIN PLUG	P24	17090	1	65	-WARNING PLATE	38816-097	17090	1
27	HEX HD CAPSCREW	B1408	17090	2	66	-DRIVE SCREW	BM#04-03	17090	2
28	LOCKWASHER	J14	17090	2	67	-FILL COVER GASKET	50G	19210	1
29	HEX HD CAPSCREW	B1207	17090	4	NOT SHOWN:				
30	LOCKWASHER	J12	17090	4		STRAINER	46641-011	17040	1
31 *	WEAR PLATE	38691-826	1718H	1		WARNING DECAL	2613FE	----	1
32	SUCTION HEAD	38246-609	17180	1		WARNING DECAL	38816-302	----	1
33	PIPE PLUG	P20	17090	1		DRIVE ASSEMBLY	44162-172	----	1
34	REDUCING PIPE BUSHINGAP2008		17090	1		WARNING DECAL	2613DK	----	2
35 *	PRESSURE RELIEF VALVE	46431-803	----	1		SUPER "T" DECAL	38812-089	----	1
36 *	VICTAULIC CLAMP	25552-212	----	1		INSTRUCTION TAG	38817-025	----	1
37	HEX HD CAPSCREW	B1414	17090	10		G-R DECAL	GR-06	----	1
38	HEX NUT	D14	17090	10		LUBE DECAL	38817-084	----	1
39	HEX HD CAPSCREW	B1414	17090	12		ROTATION DECAL	2613M	----	1

* INDICATES PARTS RECOMMENDED FOR STOCK

✓ VITON® IS A REGISTERED TRADEMARK OF THE DUPONT CORP.

SECTION DRAWING

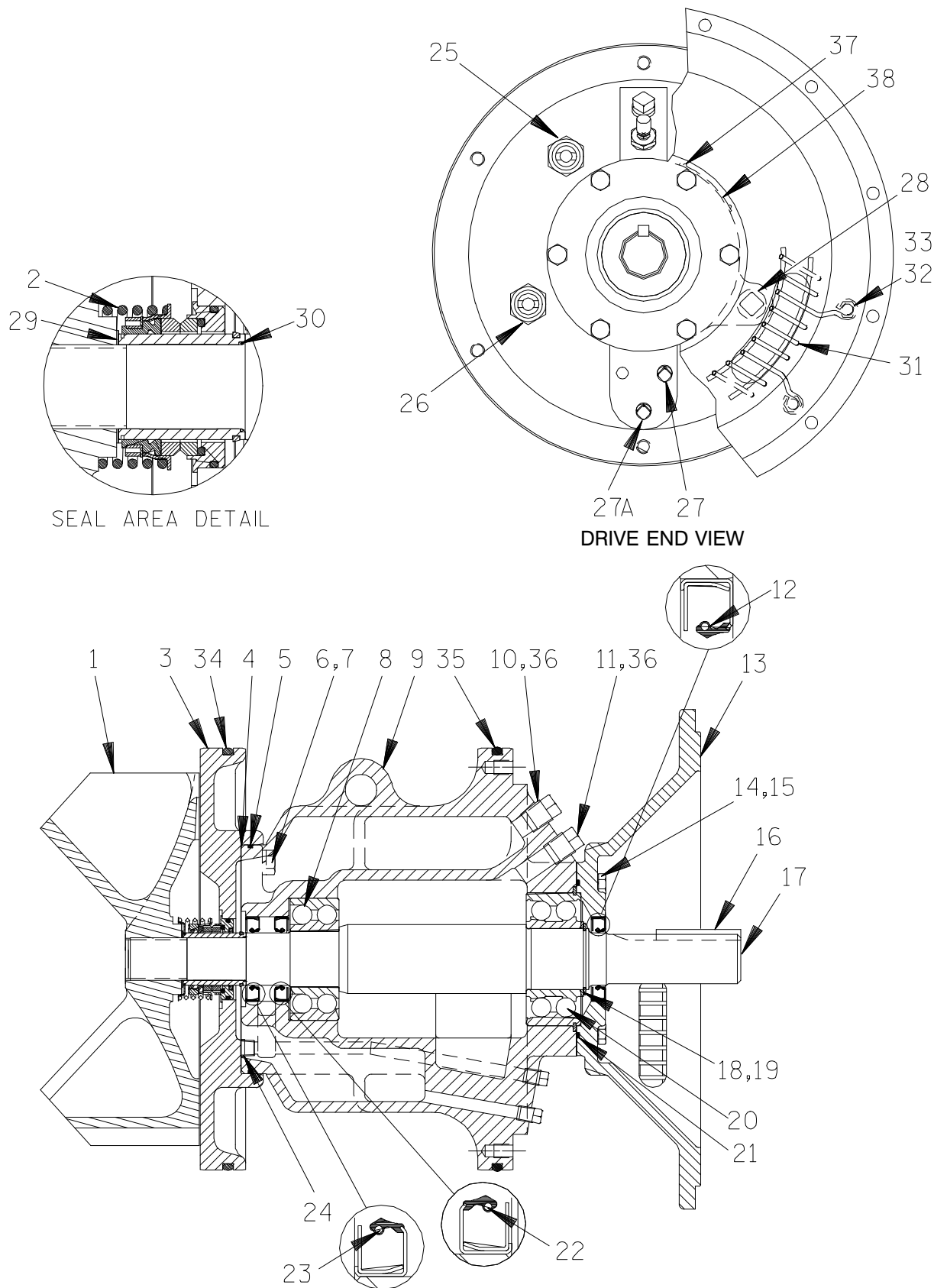
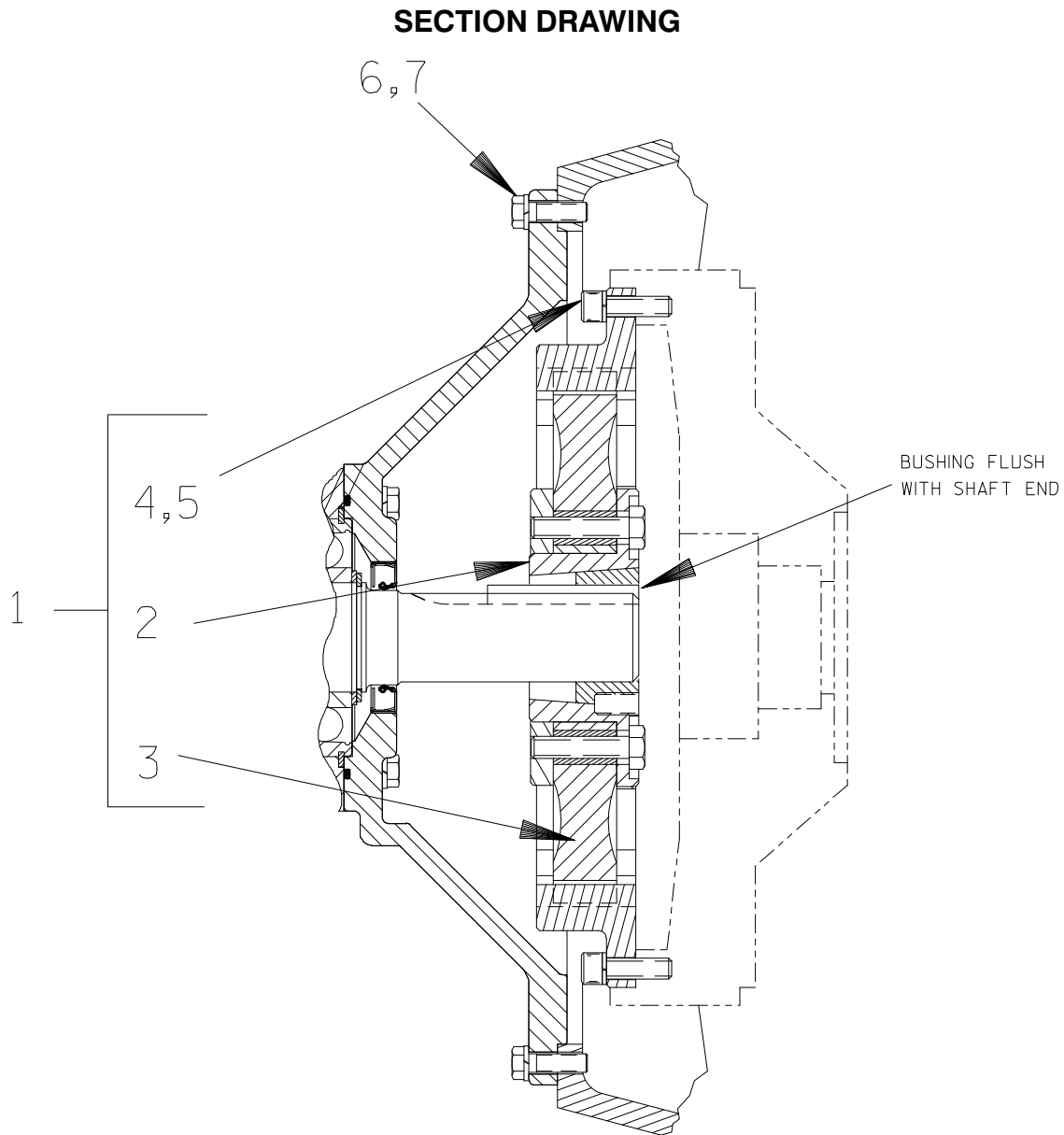

Figure 4. 44163-487 Repair Rotating Assembly

PARTS LIST
44163-487 Repair Rotating Assembly

ITEM NO.		PART NAME	PART NUMBER	MAT'L CODE	QTY
1	*	IMPELLER	38615-072	1718H	1
2	*	CARTRIDGE SEAL ASSEMBLY	46513-159	----	1
3		SEAL PLATE	38272-228	1718H	1
4	*	SEAL PLATE GASKET	38684-302	19410	1
5	*	BEARING HOUSING O-RING	25154-265	----	1
6		HEX HD CAPSCREW	B0808	17090	4
7		LOCKWASHER	J08	17090	4
8	*	BALL BEARING	23421-461	----	1
9		BEARING HOUSING	38251-519	17180	1
10		VENTED PLUG	4823A	17040	1
11		VENTED PLUG	4823A	17040	1
12	*	DRIVE FLANGE OIL SEAL	S1917	----	1
13		DRIVE FLANGE	38545-007	11010	1
14		HEX HD CAPSCREW	B0605-1/2	17090	6
15		LOCKWASHER	J06	17090	6
16	*	SHAFT KEY	N0612	17040	1
17	*	IMPELLER SHAFT	38515-590	1706H	1
18		RETAINING RING	S215	----	1
19		THRUST WASHER	31134-113	15210	1
20	*	BALL BEARING	23422-412	----	1
21	*	DRIVE FLANGE O-RING	25154-252	----	1
22	*	INBOARD BEARING HOUSING OIL SEAL	S1917	----	1
23	*	OUTBOARD BEARING HOUSING OIL SEAL	S1917	----	1
24		SOCKET HD PIPE PLUG	PC04	17090	1
25		SEAL CAVITY SIGHT GUAGE	S1471	----	1
26		BEARING HOUSING SIGHT GUAGE	S1471	----	1
27		BEARING CAVITY DRAIN PLUG	P04	17090	1
27A		SEAL CAVITY DRAIN PLUG	P04	17090	1
28		PIPE PLUG	P12	17090	1
29	*	IMPELLER ADJUSTING SHIM SET	5091	17090	REF
30	*	SHAFT SLEEVE O-RING	25154-026	----	1
31		INTERMEDIATE GUARD	42381-509	24152	2
32		HEX HD CAPSCREW	B0603	15991	4
33		LOCKWASHER	J06	15991	4
34	*	SEAL PLATE O-RING	25154-458	----	1
35		BEARING HOUSING O-RING	25154-458	----	1
36		SHIPPING PLUG	11495B	15079	2
37		SERIAL NUMBER PLATE	2613GG	17020	1
38		DRIVE SCREW	BM#04-03	17000	2
NOT SHOWN:					
		ROTATING ASSY ADJUSTMENT SHIM SET	48261-056	----	1
		INSTRUCTION TAG	6588U	----	1
		ROTATION DECAL	2613M	----	1

* INDICATES PARTS RECOMMENDED FOR STOCK



**Figure 5. 44162-172 Drive Assembly
PARTS LIST**

ITEM NO.	PART NAME	PART NUMBER	MAT'L CODE	QTY
1	COUPLING KIT	48112-016	---	1
2	-BUSHING	24131-497	---	1
3	-COUPLING ASSEMBLY	24391-102	---	1
4	-LOCKWASHER	21171-536	---	8
SAE APPLICATION				
5	SOCKET HD CAPSCREW	BD0606	15991	8
6	HEX HD CAPSCREW	B0605	15991	12
7	LOCKWASHER	J06	15991	12
METRIC APPLICATION				
5	SOCKET HD CAPSCREW	22644-218	---	8
6	HEX HD CAPSCREW	22645-164	---	12
7	LOCKWASHER	21171-511	---	12

PUMP AND SEAL DISASSEMBLY AND REASSEMBLY

Review all SAFETY information in Section A.

Follow the instructions on all tags, label and decals attached to the pump.

This pump requires little service due to its rugged, minimum-maintenance design. However, if it becomes necessary to inspect or replace the wearing parts, follow these instructions which are keyed to the sectional views (see Figures 1, 2, 3, 4 and 5) and the accompanying parts lists.

This manual will alert personnel to known procedures which require special attention, to those which could damage equipment, and to those which could be dangerous to personnel. However, this manual cannot possibly anticipate and provide detailed precautions for every situation that might occur during maintenance of the unit. Therefore, it is the responsibility of the owner/maintenance personnel to ensure that **only** safe, established maintenance procedures are used, and that any procedures not addressed in this manual are performed **only** after establishing that neither personal safety nor pump integrity are compromised by such practices.

Many service functions may be performed by draining the pump and removing the back cover assembly. If major repair is required, the piping and/or power source must be disconnected. The following instructions assume complete disassembly is required.

Before attempting to service the pump, disconnect or lock out the power source and take precautions to ensure that it will remain inoperative. Close all valves in the suction and discharge lines.

For engine disassembly and repair, consult the literature supplied with the engine, or contact your local John Deere engine representative.



Before attempting to open or service the pump:

1. Familiarize yourself with this manual.
2. Switch off the engine ignition and disconnect the positive battery cable to ensure that the pump will remain inoperative.
3. Allow the pump to completely cool if overheated.
4. Check the temperature before opening any covers, plates, or plugs.
5. Close the suction and discharge valves.
6. Vent the pump slowly and cautiously.
7. Drain the pump.



Use lifting and moving equipment in good repair and with adequate capacity to prevent injuries to personnel or damage to equipment.



This pump is designed to handle materials which could cause illness or injury through direct exposure or emitted fumes. Wear adequate protective clothing when working on the pump or piping.

Cleanout Access And Suction Check Valve Removal

(Figure 3)

Before attempting to service the pump, remove the casing drain plug (26) and drain the pump. Clean and reinstall the drain plug.

For cleanout access, loosen the clamp screws (7) and clamp bars (5) securing the cleanout cover (4) to the suction head (32).

To remove the check valve assembly, reach through the cleanout opening and remove the hardware (48, 50 and 51) securing the check valve (54) to the valve body (53) and suction head.

NOTE

An alternate method of removing the check valve assembly is to remove the hardware securing the valve body to the suction piping. Disconnect the shoulder-type coupling (36) and separate the valve body and check valve from the suction head. Separate the check valve from the valve body as described above.

Replace the cleanout cover gasket (3) before reinstalling the cover.

Suction Head And Wear Plate Removal

(Figure 3)

To remove the suction head, support it with a suitable hoist and sling and remove the hardware (27, 29, 29 and 30) securing it to the pump casing. Remove the suction head gasket (25).

If the wear plate (31) does not slide easily from the casing bore, install capscrews (1/2-13 UNC X 1 inch long, not supplied) in the tapped holes in the wear plate and use a suitable puller to remove the wear plate from the pump casing.

NOTE

An alternate method of removing the wear plate is to position a wood or soft metal wedge between the impeller vanes and the wear plate, and tap the wedge with a hammer. Turn the impeller every 45°, repeating the process until the wear plate is "walked" out of the pump casing.

If the pump is to be completely disassembled, the wear plate can also be easily removed after removing the rotating assembly (2). Use a suitably sized piece of wood to tap the wear plate out of the casing through the rotating assembly opening.

Separating Pump And Drive Assembly From Engine

(Figure 3)

Further disassembly requires separating the pump end and drive assembly from the engine. Remove the discharge elbow and gasket (10 and 13) and fill cover and gasket (64 and 67) from the pump casing. Loop a suitable chain or cable through the discharge port and back out the priming port and attach it to a hoist.



Make certain the chain or cable is positioned so that the pump will not be damaged, and so that the load will be balanced.

(Figure 5)

Disengage the hardware (6 and 7) securing the drive flange (14, Figure 2) to the engine bellhousing, and remove the guards (35, Figure 4). Separate the pump end and drive assembly from the engine by pulling the pump end straight away from the engine.

As the assemblies separate, the flexible portion of the coupling assembly (3) will remain on the shaft. To remove the coupling from the shaft, unscrew the two allen head setscrews from the bushing (2). Screw one of the setscrews into the puller hole on the circumference of the bushing. As the coupling and bushing separate, remove the bushing, and slide the coupling off the shaft.

It is not necessary to remove the outer ring of the coupling from the engine flywheel unless the coupling must be replaced. To remove the ring, disengage the hardware (4 and 5) securing it to the flywheel.

Remove any leveling shims used under the casing mounting feet. Tie and tag the shims for ease of reassembly.

Move the pump end to a clean, well equipped shop area for further disassembly.

Loosening Impeller

(Figure 4)

Before attempting to loosen the impeller, remove the seal cavity drain plug (27A) and drain the lubri-

cant. This will prevent the oil from escaping as the impeller is removed. Clean and reinstall the drain plug.

With the pump end separated from the engine and the suction head (32, Figure 3) removed, wedge a block of wood between the vanes of the impeller and the pump casing to prevent rotation.

If removed, install the shaft key (16) in the shaft keyway. Install a lathe dog on the drive end of the shaft (18) with the "V" notch positioned over the shaft key.

With the impeller rotation still blocked, see Figure 6 and use a long piece of heavy bar stock to pry against the arm of the lathe dog in a counterclockwise direction (when facing the drive end of the shaft). **Use caution** not to damage the shaft or keyway. When the impeller breaks loose, remove the lathe dog, key and wood block.

NOTE

Do not remove the impeller until the rotating assembly has been removed from the pump casing.

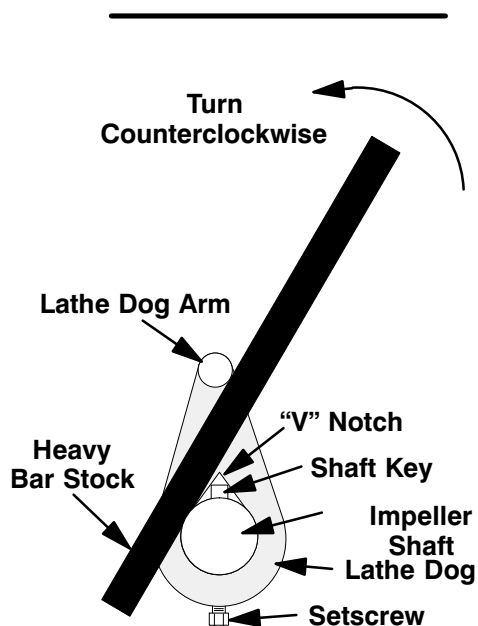

Figure 6. Loosening Impeller

Rotating Assembly Removal

(Figure 3)

To ease removal of the rotating assembly, it is recommended that the pump be positioned on sup-

porting blocks with the suction head opening down and the drive flange (13, Figure 4) up.

Remove the outer hardware (17 and 18) from the casing ring (16). Install three of the outer cap-screws in the jacking holes in the casing ring, and use them to jack the rotating assembly loose from the pump casing.

After the rotating assembly is loosened, remove the jacking screws from the casing ring. Remove the inner hardware (19 and 20) and shim sets (22). Separate the casing ring from the pump casing. Tie and tag the shim sets for ease of reassembly.

Install hooks in the mounting holes in the drive flange (13, Figure 4) and attach the hooks to a three-legged sling and suitable lifting device. Carefully lift the rotating assembly out of the pump casing far enough to reach inside the casing and remove the seal plate O-ring (23). With the O-ring removed, the rotating assembly can be easily removed from the casing using the lifting device.

Move the rotating assembly to a suitable work area for further disassembly.

Impeller And Wear Plate Removal

(Figure 4)

Unscrew the impeller from the shaft in a counterclockwise direction (when facing the impeller). Use caution when unscrewing the impeller; tension on the shaft seal spring will be released as the impeller is removed.

Remove the impeller adjusting shims (29). Tie and tag the shims or measure and record their thickness for ease of reassembly.

Seal Removal And Disassembly

(Figure 4)

Slide the integral shaft sleeve and rotating portion of the seal off the shaft as a unit.

Use a pair of stiff wires with hooked ends to remove the stationary element and seat.

An alternate method of removing the stationary portion of the seal is to remove the hardware (6 and 7) and separate the seal plate (3) and gasket (4)

from the bearing housing (9). Remove the bearing housing O-ring (5).

Position the seal plate on a flat surface with the impeller side down. Use a wooden dowel or other suitable tool to press on the back side of the stationary seat until the seat, O-rings, and stationary element can be removed.

If no further disassembly is required, refer to **Seal Installation**.

Shaft and Bearing Removal and Disassembly

(Figure 4)

When the pump is properly operated and maintained, the bearing housing should not require disassembly. Disassemble the shaft and bearings **only** when there is evidence of wear or damage.



Shaft and bearing disassembly in the field is not recommended. These operations should be performed only in a properly equipped shop by qualified personnel.

Remove the bearing housing drain plug (27) and drain the lubricant. Clean and reinstall the drain plug.

Disengage the hardware (14 and 15) and remove the drive flange (13), O-ring (21) and oil seal (12) from the shaft. Press the oil seal from the drive flange.

Place a block of wood against the impeller end of the shaft (17) and tap the shaft and assembled bearings (8 and 20) from the bearing housing.

After removing the shaft and bearings, clean and inspect the bearings **in place** as follows.



To prevent damage during removal from the shaft, it is recommended that bearings be cleaned and inspected **in place**. It is

strongly recommended that the bearings be replaced **any** time the shaft and bearings are removed.

Clean the bearing housing, shaft and all component parts (except the bearings) with a soft cloth soaked in cleaning solvent. Inspect the parts for wear or damage and replace as necessary.



Most cleaning solvents are toxic and flammable. Use them only in a well ventilated area free from excessive heat, sparks, and flame. Read and follow all precautions printed on solvent containers.

Clean the bearings thoroughly in **fresh** cleaning solvent. Dry the bearings with filtered compressed air and coat with light oil.



Bearings must be kept free of all dirt and foreign material. Failure to do so will greatly shorten bearing life. **Do not** spin dry bearings. This may scratch the balls or races and cause premature bearing failure.

Rotate the bearings by hand to check for roughness or binding and inspect the bearing balls. If rotation is rough or the bearing balls are discolored, replace the bearings.

The bearing tolerances provide a tight press fit onto the shaft and a snug slip fit into the bearing housing. Replace the bearings, shaft, or bearing housing if the proper bearing fit is not achieved.

If bearing replacement is required, remove the outboard bearing retaining ring (18) and thrust washer (19) and use a bearing puller or an arbor (or hydraulic) press to remove the bearings from the shaft.

Press the oil seals (22 and 23) from the bearing housing bore.

Shaft and Bearing Reassembly and Installation

(Figures 4 and 7)

Clean the bearing housing, shaft and all component parts (except the bearings) with a soft cloth soaked in cleaning solvent. Inspect the parts for wear or damage as necessary.



Most cleaning solvents are toxic and flammable. Use them only in a well ventilated area free from excessive heat, sparks, and flame. Read and follow all precautions printed on solvent containers.

Inspect the shaft for distortion, nicks or scratches, or for thread damage on the impeller end. Dress small nicks and burrs with a fine file or emery cloth. Replace the shaft if defective.

Position the inboard oil seal (22) in the bearing housing bore with the lip positioned as shown in Figure 4. Press the oil seal into the housing until the face is **just flush** with the machined surface inside the housing.



To prevent damage during removal from the shaft, it is recommended that bearings

be cleaned and inspected **in place**. It is **strongly** recommended that the bearings be replaced **any** time the shaft and bearings are removed.

The bearings may be heated to ease installation. An induction heater, hot oil bath, electric oven, or hot plate may be used to heat the bearings. Bearings should **never** be heated with a direct flame or directly on a hot plate.

NOTE

*If a hot oil bath is used to heat the bearings, both the oil and the container must be **absolutely** clean. If the oil has been previously used, it must be **thoroughly** filtered.*

Heat the bearings to a uniform temperature **no higher than 250°F (120°C)**, and slide the bearings onto the shaft, one at a time, until they are fully seated. This should be done quickly, in one continuous motion, to prevent the bearings from cooling and sticking on the shaft.



Use caution when handling hot bearings to prevent burns.

NOTE

Position the inboard bearing (8) on the shaft as indicated by the following illustration.

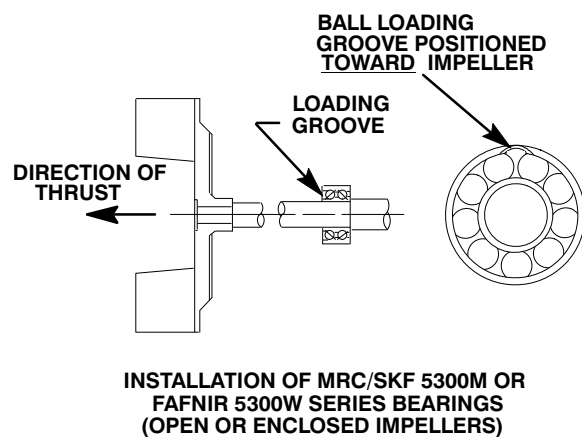
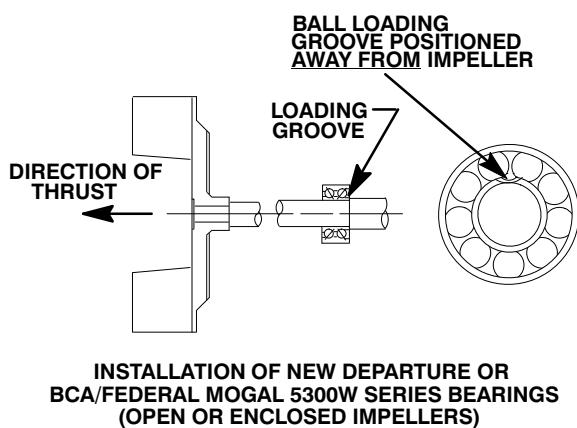

Figure 7. Inboard Bearing Positioning

NOTE

Position the outboard bearing (20) on the shaft with the retaining ring in the outer race toward the drive end of the shaft.

After the bearings have been installed and allowed to cool, check to ensure that they have not moved away from the shaft shoulders in shrinking. If movement has occurred, use a suitable sized sleeve and a press to reposition the bearings against the shaft shoulders.

If heating the bearings is not practical, use a suitable sized sleeve, and an arbor (or hydraulic) press to install the bearings on the shaft.



When installing the bearings onto the shaft, **never** press or hit against the outer race, balls, or ball cage. Press **only** on the inner race.

Install the thrust washer (18) and secure the outboard bearing (20) to the shaft with the bearing retaining ring (19).

It is recommended that a sleeve be positioned against the inboard oil seal (22) to prevent the lip of the oil seal from rolling as the shaft and bearings are installed in the bearing housing. The O.D. of the sleeve should be just smaller than the bearing housing bore, while the I.D. of the sleeve should be just larger than the O.D. of the lip seal area of the shaft.

With the lip seal sleeve in place, lubricate the lip seal area of the shaft, and slide the shaft and assembled bearings into the bearing housing until the retaining ring on the outboard bearing seats against the bearing housing. Remove the lip seal sleeve.



When installing the shaft and bearings into the bearing bore, push against the outer race. **Never** hit the balls or ball cage.

Position the outboard oil seal (23) in the bearing housing with the lip positioned as shown in Figure 4. Press the oil seal into the bearing housing until it is **just flush** with the machined surface on the bearing housing.

Press the oil seal (12) into the drive flange (13) with the lip positioned as shown in Figure 4. Replace the drive flange O-ring (21) and secure the drive flange with the hardware (14 and 15). Be careful not to damage the lip of the oil seal (12) on the shaft keyway.

Lubricate the bearing housing as indicated in **LUBRICATION** at the end of this section.

Seal Reassembly And Installation

(Figures 4 and 8)

Clean the seal cavity and shaft with a cloth soaked in fresh cleaning solvent.



Most cleaning solvents are toxic and flammable. Use them only in a well ventilated area free from excessive heat, sparks, and flame. Read and follow all precautions printed on solvent containers.

The seal is not normally reused because wear patterns on the finished faces cannot be realigned during reassembly. This could result in premature failure. If necessary to reuse an old seal in an emergency, **carefully** wash all metallic parts in fresh cleaning solvent and allow to dry thoroughly.

Handle the seal parts with extreme care to prevent damage. Be careful not to contaminate precision finished faces; even fingerprints on the faces can shorten seal life. If necessary, clean the faces with a non-oil based solvent and a clean, lint-free tissue. Wipe **lightly** in a concentric pattern to avoid scratching the faces.

Inspect the seal components for wear, scoring, grooves, and other damage that might cause leakage. Inspect the seal area of the impeller shaft, and replace it if badly damaged. Dress any small scratches with a fine file or emery cloth. If any components are worn, replace the complete seal; **never mix old and new seal parts.**

If a replacement seal is being used, remove it from the container and inspect the precision finished faces to ensure that they are free of any foreign matter.

lows and stationary seat O-rings with water or a very **small** amount of oil, and apply a drop of light lubricating oil on the finished faces. Assemble the seal as follows, (see Figure 8).

To ease installation of the seal, lubricate the bel-

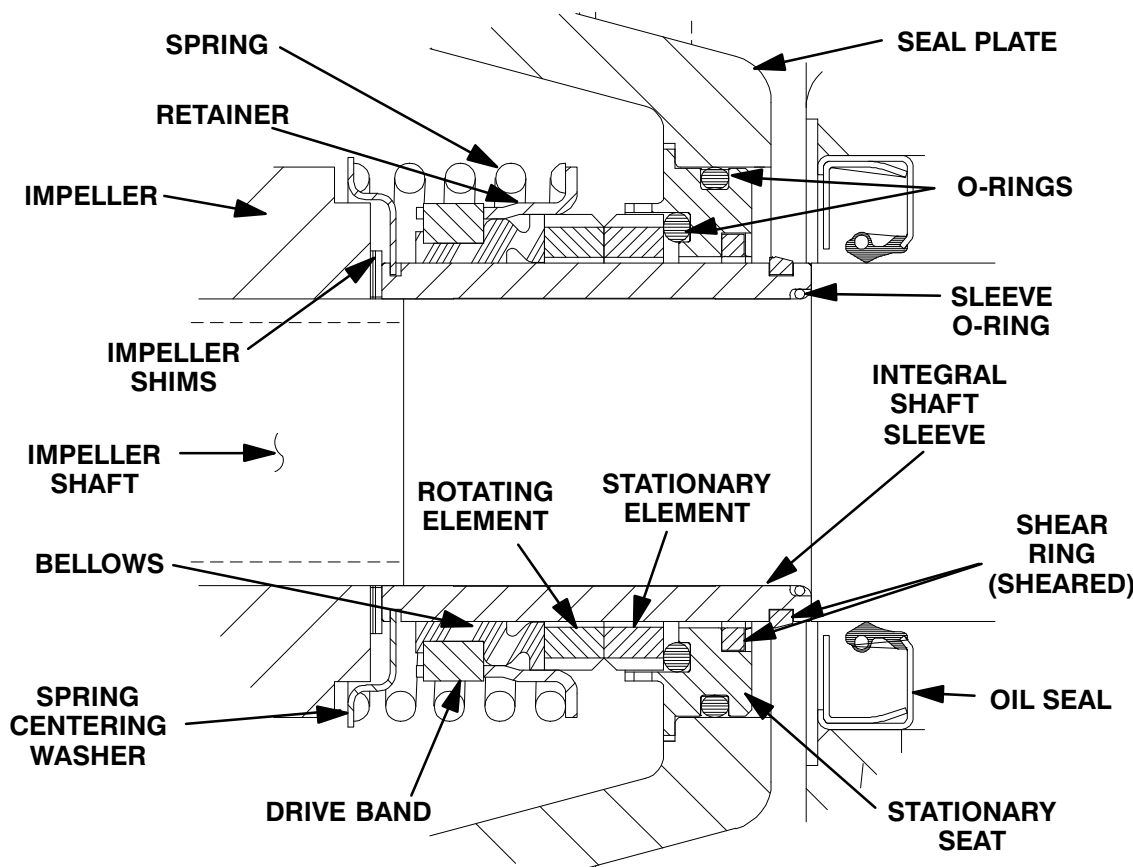
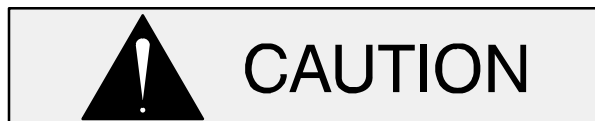

Figure 8. 46513-159 Seal Assembly



This seal is not designed for operation at temperatures above 160°F (71°C). Do not use at higher operating temperatures.

If the seal plate was removed, install the seal plate gasket (4) and bearing housing O-ring (5). Lubricate the O-ring with light grease. Position the seal plate over the shaft and secure it to the bearing housing with the hardware (6 and 7).

To prevent damaging the shaft sleeve O-ring (30) on the shaft threads, stretch the O-ring over a piece of tubing 1-1/2" I.D. x 1-3/4" O.D. x 2-inches long (38 mm x 45 mm x 51 mm). Slide the tube over the

shaft threads, then slide the O-ring off the tube and onto the shaft. Remove the tube, and continue to slide the O-ring down the shaft until it seats against the shaft shoulder.

When installing a new cartridge seal assembly, remove the seal from the container, and lubricate the external stationary seat O-ring with light oil. Slide the seal assembly onto the shaft until the external stationary seat O-ring engages the bore in the seal plate.

Clean and inspect the impeller as described in **Impeller Installation and Adjustment**. Install the full set of impeller shims (29) provided with the seal, and screw the impeller onto the shaft until it is seated against the seal (see Figure 9).

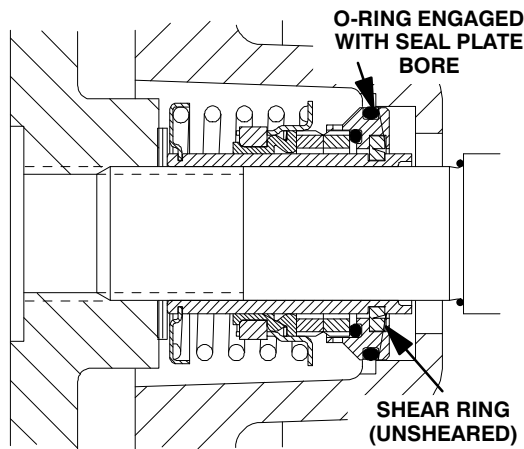

Figure 9. Seal Partially Installed

Continue to screw the impeller onto the shaft. This will press the stationary seat into the seal plate bore.

NOTE

A firm resistance will be felt as the impeller presses the stationary seat into the seal plate bore.

As the stationary seat becomes fully seated, the seal spring compresses, and the shaft sleeve will break the nylon shear ring. This allows the sleeve to slide down the shaft until seated against the shaft shoulder. Continue to screw the impeller onto the shaft until the impeller, shims, and sleeve are fully seated against the shaft shoulder (see Figure 10).

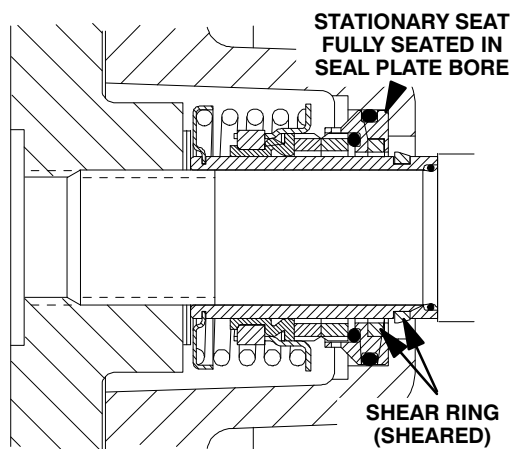
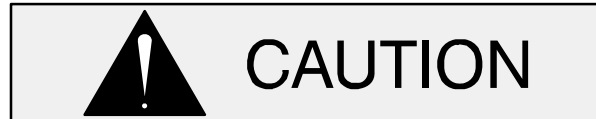

Figure 10. Seal Fully Installed

Measure the impeller-to-seal plate clearance, and remove impeller adjusting shims to obtain the

proper clearance as described in **Impeller Installation and Adjustment**.

If necessary to reuse an old seal in an emergency, carefully separate the rotating and stationary seal faces from the bellows retainer and stationary seat.



A new seal assembly should be installed **any time** the old seal is removed from the pump. Wear patterns on the finished faces cannot be realigned during reassembly. Reusing an old seal could result in premature failure.

Handle the seal parts with extreme care to prevent damage. Be careful not to contaminate precision finished faces; even fingerprints on the faces can shorten seal life. If necessary, clean the faces with a non-oil based solvent and a clean, lint-free tissue. Wipe **lightly** in a concentric pattern to avoid scratching the faces.

Carefully wash all metallic parts in fresh cleaning solvent and allow to dry thoroughly.



Do not attempt to separate the rotating portion of the seal from the shaft sleeve when reusing an old seal. The rubber bellows will adhere to the sleeve during use, and attempting to separate them could damage the bellows.

Inspect the seal components for wear, scoring, grooves, and other damage that might cause leakage. Inspect the integral shaft sleeve for nicks or cuts on either end. If any components are worn, or the sleeve is damaged, replace the complete seal; **never mix old and new seal parts**.

Install the stationary seal element in the stationary seat. Press this stationary subassembly into the seal plate bore until it seats squarely against the bore shoulder. A push tube made from a piece of plastic pipe would aid this installation. The I.D. of the pipe should be slightly larger than the O.D. of the shaft sleeve.

Slide the rotating portion of the seal (consisting of the integral shaft sleeve, spring centering washer, spring, bellows and retainer, and rotating element) onto the shaft until the seal faces contact.

Proceed with **Impeller Installation and Adjustment**.

Impeller Installation

(Figure 4)

Inspect the impeller, and replace it if cracked or badly worn. Inspect the impeller and shaft threads for dirt or damage, and clean or dress the threads as required.



The shaft and impeller threads **must** be completely clean before reinstalling the impeller. Even the slightest amount of dirt on the threads can cause the impeller to seize to the shaft, making future removal difficult or impossible without damage to the impeller or shaft.

Install the same thickness of impeller adjusting shims (29) as previously removed. Apply 'Never-Seez' or equivalent compound to the shaft threads and screw the impeller onto the shaft until tight. **Be sure** the seal spring seats squarely over the shoulder on the back side of the impeller.

NOTE

At the slightest sign of scraping, immediately back the impeller off, and check the threads for dirt. Do not try to force the impeller onto the shaft.

A clearance of .020 to .025 inch (0,51 to 0,64 mm) between the impeller and the wear plate is recommended for maximum pump efficiency. Measure this clearance, and add or remove impeller adjusting shims as required.

NOTE

If the rotating assembly has been installed in the pump casing, this clearance may be measured by reaching through the priming port with a feeler gauge.

Rotating Assembly Installation

(Figure 3)

Install the bearing housing and seal plate O-rings (21 and 23), and lubricate them with light grease. Ease the rotating assembly into the pump casing. **Be careful** not to damage the O-rings.

Install the pump casing ring (16), and secure it to the rotating assembly with the inner hardware (19 and 20).

NOTE

The inner capscrews are 1/4 inch (3,2 mm) shorter than the outer capscrews.

Install an equal thickness of rotating assembly shims (22) under the pump casing ring, and secure the ring to the pump casing with the outer hardware (17 and 18).

NOTE

If the pump has been completely disassembled, it is recommended that the wear plate (31) and suction head (32) be reinstalled at this point. The suction head and wear plate must be in place to adjust the impeller face clearance.

A clearance of .020 to .025 inch (0,51 to 0,64 mm) between the impeller and the wear plate is also recommended for maximum pump efficiency. This clearance can be obtained by removing an equal amount of shims from each rotating assembly shim set (22) until the impeller scrapes against the wear plate when the shaft is turned by hand. After the impeller scrapes, add approximately .020 (0,51 mm) of shims to each shim set.

NOTE

An alternate method of adjusting this clearance is to reach through the suction port with a feeler gauge and measure the gap. Add or subtract rotating assembly shims accordingly.

Suction Head And Wear Plate Installation

(Figure 3)

Clean any scale or debris from the contacting surfaces in the pump casing that might prevent a

good seal with the suction head or interfere with the wear plate (31). Inspect the wear plate for excessive wear or damage and replace as required. Slide the wear plate into the pump casing until fully seated.

Replace the suction head gasket (25) and lubricate it with a generous amount of No. 2 grease. Use a suitable hoist and sling to position the suction head against the pump casing, and secure it with the hardware (27, 28, 29 and 30).

NOTE

To ease future disassembly, apply a film of grease or 'Never-Seez' on the suction head, or any surface which contacts the pump casing. This action will reduce rust and scale build-up.

Suction Check Valve Installation

(Figure 3)

Inspect the check valve components and replace if badly worn.

Reach through the cleanout cover opening with the check valve and secure it with the pivot caps (52) and hardware (48, 50 and 51).

NOTE

If the check valve body (53) was removed, install the check valve and secure the body to the suction head with the shoulder type clamp (36).

Securing Pump End To Engine

(Figure 5)

Install the shaft key (17, Figure 4) in the shaft keyway. Position the flexible portion of the coupling assembly (3) on the shaft as shown in Figure 5.

Align the keyway in the bushing (2) with the shaft key, and slide it onto the shaft until it is **just flush** with the end of the shaft. Rotate the flexible portion of the coupling until the tapped holes for the two setscrews align with those in the bushing, and install the setscrews.



Make certain that the flexible portion of the coupling is mounted as shown in Figure 5. **This is critical.** If the coupling is not properly positioned on the shaft, the coupling parts may not fully engage, or a pre-load condition can cause premature bearing failure.

The end of the shaft must be **just flush** with the face of the bushing. This will allow the two portions of the coupling to fully engage when the drive flange is secured to the engine bellhousing, without pre-loading the bearings.

With the flexible portion of the coupling and the bushing properly positioned on the shaft, tighten the two setscrews in an alternating sequence until the bushing and coupling are fully secured. Torque the setscrews to 23.3 ft. lbs. (280 in. lbs. or 3,2 m. kg.).

If the complete coupling assembly is being replaced, apply 'Loctite Retaining Compound No. 242' or equivalent to the threads of the hardware (4 and 5), and secure the outer ring of the coupling to the engine flywheel by torquing the hardware to 45 ft. lbs. (540 in. lbs. or 6,2 m. kg.).

Using a suitable lifting device, position the pump end so the flexible portion of the coupling seats inside the outer ring attached to the engine flywheel.

NOTE

*To ease installation, **lightly** lubricate the rubber portion of the coupling with a **non-petroleum based lubricant** such as vegetable oil or glycerin, or a silicon-based lubricant such as "WD40" or equivalent. **Do not** use petroleum-based lubricants, or any other substance which may soften or otherwise damage the rubber.*

Install the intermediate guards (31, Figure 4), and secure the drive flange to the engine bellhousing with the hardware (6 and 7).

Install any leveling shims used under the casing mounting feet, and secure the casing to the base with the previously removed hardware.

PRESSURE RELIEF VALVE MAINTENANCE

(Figure 3)

The suction head is equipped with a pressure relief valve (35) to provide additional safety for the pump and operator (refer to **Liquid Temperature And Overheating** in **OPERATION**).

It is recommended that the pressure relief valve assembly be replaced at each overhaul, or any time the pump overheats and activates the valve. **Never** replace this valve with a substitute which has not been specified or provided by the Gorman-Rupp Company.

Periodically, the valve should be removed for inspection and cleaning. When reinstalling the relief valve, apply 'Loctite Pipe Sealant With Teflon No. 592', or equivalent compound, on the relief valve threads. Position the valve as shown in Figure 3, with the discharge port pointing down.

LUBRICATION

Seal Assembly

(Figure 4)

Before starting the pump, remove the vented plug (10) and fill the seal cavity with approximately 85 ounces (2,5 liters) of SAE No. 30 non-detergent oil, or to a level at the middle of the sight gauge (25). Clean and reinstall the vented plug. Maintain the oil at this level.

Bearings

(Figure 4)

The bearing housing was fully lubricated when shipped from the factory. Check the oil level regu-

larly through the sight gauge (26) and maintain it at the middle of the gauge. When lubrication is required, remove the vented plug (11) and add SAE No. 30 non-detergent oil through the hole until the level is at the middle of the sight gauge. **Do not** over-lubricate. Over-lubrication can cause the bearings to over-heat, resulting in premature bearing failure.

NOTE

The white reflector in the sight gauge must be positioned horizontally to provide proper drainage.

Under normal conditions, drain the bearing housing once each year and refill with approximately 32 ounces (1 liter) clean oil. Change the oil more frequently if the pump is operated continuously or installed in an environment with rapid temperature change.



Monitor the condition of the bearing lubricant regularly for evidence of rust or moisture condensation. This is especially important in areas where variable hot and cold temperatures are common.

For cold weather operation, consult the factory or a lubricant supplier for the recommended grade of oil.

Engine

Consult the literature supplied with the engine, or contact your local engine representative.

THE GORMAN-RUPP COMPANY AND GORMAN-RUPP OF CANADA LIMITED

60 MONTH LIMITED WARRANTY

EXTENT AND DURATION OF WARRANTY

Coverage: The Gorman-Rupp Company or Gorman-Rupp of Canada Limited (herein individually referred to as "GR") each individually warrant that its products and parts shall be free from defects in material and workmanship for sixty (60) months from the date of purchase by the original end user.

Exceptions: This Limited Warranty shall not apply to the following products and parts: engines, motors, trade accessories and other products, components or materials not manufactured by GR. Wear and tear resulting from normal use is not covered by this Limited Warranty.

LIMITATIONS

GR'S SOLE AND EXCLUSIVE WARRANTY WITH RESPECT TO ITS PRODUCTS AND PARTS IS THIS LIMITED WARRANTY. THIS LIMITED WARRANTY IS IN LIEU OF ALL OTHER EXPRESS AND/OR IMPLIED WARRANTIES, INCLUDING IMPLIED WARRANTIES OF MERCHANTABILITY AND FITNESS FOR PARTICULAR PURPOSE.

EXCLUSIVE REMEDY AND DAMAGES

The sole and exclusive remedy for breach of this Limited Warranty by GR, and the entire extent of its liability for such breach or for damages arising and/or resulting from the use of the products and parts covered by this Limited Warranty shall be as follows:

1. **Repair or replacement:** If inspection shows that any GR product or part covered under this Limited Warranty is defective in materials or workmanship, GR shall repair or replace the defective product or part at its option, without charge. You must have properly installed, maintained and used the product or part claimed to be defective in accordance with the maintenance schedule and/or manual which comes with the product. *No allowance will be made for labor, transportation or other charges incurred by you in connection with such repair or replacement.*
2. **To obtain the above remedy:**
 - a) Immediately notify GR at the address below of the claimed defect in materials or workmanship and provide the serial number or date code of the product and/or part and provide a copy of the invoice or bill of sale referencing the product and/or part by no later than the expiration date of the Limited Warranty period.
 - b) GR will advise whether inspection of the product and/or part will be necessary and whether and how repair or replacement will be effected. If inspection by GR is necessary, the product or part must be sent freight prepaid to GR at the address stated below. Return shipment of the repaired product or part will be F.O.B. the address stated below.
3. **Damages:** GR's liability for damages for breach of this Limited Warranty shall not exceed the amount of the purchase price of the product or part in respect to which damages are claimed. **IN NO EVENT SHALL GR BE LIABLE FOR INCIDENTAL, CONSEQUENTIAL OR SPECIAL DAMAGES FOR BREACH OF THIS LIMITED WARRANTY OTHER THAN STATED HEREIN.**

Some states do not allow the exclusion or limitation of incidental or consequential damages. Accordingly, the above may not apply to you. This Limited Warranty gives you specific legal rights, and you may also have other rights which vary from state to state and province to province.

THE GORMAN-RUPP COMPANY
P.O. BOX 1217
MANSFIELD, OH 44901-1217
Phone: (419) 755-1011

GORMAN-RUPP OF CANADA LIMITED
70 Burwell Road
St. Thomas, Ontario N5P 3R7
Phone: (519) 631-2870