

**INSTALLATION, OPERATION,
AND MAINTENANCE MANUAL**
WITH PARTS LIST



PA SERIES PUMP

MODEL
PA4C22-4045H

THE GORMAN-RUPP COMPANY • MANSFIELD, OHIO

GORMAN-RUPP OF CANADA LIMITED • ST. THOMAS, ONTARIO, CANADA Printed in U.S.A

www.grpumps.com

©2011 The Gorman-Rupp Company

Register your new
Gorman-Rupp pump online at
www.grpumps.com

Valid serial number and e-mail address required.



The engine exhaust from this product contains chemicals known to the State of California to cause cancer, birth defects or other reproductive harm.

RECORD YOUR PUMP MODEL AND SERIAL NUMBER

Please record your pump model and serial number in the spaces provided below. Your Gorman-Rupp distributor needs this information when you require parts or service.

Pump Model: _____

Serial Number: _____

TABLE OF CONTENTS

INTRODUCTION	PAGE I – 1
SAFETY - SECTION A	PAGE A – 1
INSTALLATION – SECTION B	PAGE B – 1
Pump Dimensions	PAGE B – 1
PREINSTALLATION INSPECTION	PAGE B – 1
Battery Installation	PAGE B – 2
POSITIONING PUMP	PAGE B – 2
Lifting	PAGE B – 2
Mounting	PAGE B – 2
SUCTION AND DISCHARGE PIPING	PAGE B – 3
Materials	PAGE B – 3
Line Configuration	PAGE B – 3
Connections to Pump	PAGE B – 3
Gauges	PAGE B – 3
SUCTION LINES	PAGE B – 3
Fittings	PAGE B – 3
Strainers	PAGE B – 3
Sealing	PAGE B – 3
Suction Lines In Sumps	PAGE B – 4
Suction Line Positioning	PAGE B – 4
DISCHARGE LINES	PAGE B – 5
Siphoning	PAGE B – 5
Valves	PAGE B – 5
ALIGNMENT	PAGE B – 5
AUTO-START	PAGE B – 5
Float Switch Installation	PAGE B – 5
OPERATION – SECTION C	PAGE C – 1
OPERATION	PAGE C – 1
PRIMING	PAGE C – 1
STARTING	PAGE C – 1
Manual Starting	PAGE C – 1
Automatic Starting	PAGE C – 2
OPERATION	PAGE C – 2
Leakage	PAGE C – 2
Pump Vacuum Check	PAGE C – 2
Liquid Temperature And Overheating	PAGE C – 2
Strainer Check	PAGE C – 2
STOPPING	PAGE C – 3
BEARING TEMPERATURE CHECK	PAGE C – 3
Cold Weather Preservation	PAGE C – 3
TROUBLESHOOTING – SECTION D	PAGE D – 1
PREVENTIVE MAINTENANCE	PAGE D – 3
PUMP MAINTENANCE AND REPAIR - SECTION E	PAGE E – 1
STANDARD PERFORMANCE CURVE	PAGE E – 1

TABLE OF CONTENTS
(continued)

PARTS LISTS:

Pump Model	PAGE E – 3
Power Unit Kit	PAGE E – 5
Pump End Assembly	PAGE E – 7
Pump Assembly	PAGE E – 9
Drive Assembly	PAGE E – 10
Priming Chamber Kit	PAGE E – 11
Priming Chamber Assembly	PAGE E – 12
PUMP AND SEAL DISASSEMBLY AND REASSEMBLY	PAGE E – 13
Priming Chamber Removal And Disassembly	PAGE E – 13
Discharge Check Valve Removal and Disassembly	PAGE E – 14
Pump Casing And Wear Ring Removal	PAGE E – 14
Impeller Removal	PAGE E – 15
Seal Removal	PAGE E – 15
Separating Pump Frame And Drive Assembly From Engine	PAGE E – 15
Pump Shaft and Bearing Removal and Disassembly	PAGE E – 15
Bearing Cleaning And Inspection	PAGE E – 16
Pump Shaft and Bearing Reassembly and Installation	PAGE E – 16
Drive Assembly Installation	PAGE E – 17
Seal Reassembly and Installation	PAGE E – 18
Impeller Installation	PAGE E – 19
Wear Ring And Pump Casing Installation	PAGE E – 20
Discharge Check Valve Assembly and Installation	PAGE E – 20
Priming Chamber Assembly And Installation	PAGE E – 21
LUBRICATION	PAGE E – 21
Seal Assembly	PAGE E – 21
Bearings	PAGE E – 21
Engine	PAGE E – 21

INTRODUCTION

Thank You for purchasing a Gorman-Rupp pump. **Read this manual** carefully to learn how to safely install and operate your pump. Failure to do so could result in personal injury or damage to the pump.

This pump is a PA Series, priming-assisted centrifugal model. The unit is designed for handling non-volatile, non-flammable liquids containing specified entrained solids. The basic material of construction is grade 316 stainless steel.

Because pump installations are seldom identical, this manual cannot possibly provide detailed instructions and precautions for every aspect of each specific application. Therefore, it is the responsibility of the owner/installer of the pump to ensure that applications not addressed in this manual are performed **only** after establishing that neither operator safety nor pump integrity are compromised by the installation. Pumps and related equipment **must** be installed and operated according to all national, local and industry standards.

If there are any questions regarding the pump which are not covered in this manual or in other literature accompanying the unit, please contact your Gorman-Rupp distributor or the Gorman-Rupp Company:

The Gorman-Rupp Company
P.O. Box 1217
Mansfield, Ohio 44901—1217
Phone: (419) 755—1011
 or:
Gorman-Rupp of Canada Limited
70 Burwell Road
St. Thomas, Ontario N5P 3R7
Phone: (519) 631—2870

For information or technical assistance on the engine, contact the engine manufacturer's local dealer or representative.

The following are used to alert personnel to procedures which require special attention, to those which could damage equipment, and to those which could be dangerous to personnel:



Immediate hazards which WILL result in severe personal injury or death. These instructions describe the procedure required and the injury which will result from failure to follow the procedure.



Hazards or unsafe practices which COULD result in severe personal injury or death. These instructions describe the procedure required and the injury which could result from failure to follow the procedure.



Hazards or unsafe practices which COULD result in minor personal injury or product or property damage. These instructions describe the requirements and the possible damage which could result from failure to follow the procedure.

NOTE

Instructions to aid in installation, operation, and maintenance or which clarify a procedure.

SAFETY - SECTION A

This information applies to Prime Aire[®] Series pumps. Refer to the manual accompanying the engine or power source before attempting to begin operation.

Because pump installations are seldom identical, this manual cannot possibly provide detailed instructions and precautions for each specific application. Therefore, it is the owner/installer's responsibility to ensure that applications not addressed in this manual are performed only after establishing that neither operator safety nor pump integrity are compromised by the installation.



Before attempting to open or service the pump:

1. Familiarize yourself with this manual.
2. Shut down the engine and disconnect the positive battery cable, or lock out incoming power to the motor and take precautions to ensure that the pump will remain inoperative.
3. Allow the pump to completely cool if overheated.
4. Check the temperature and make sure the pump is cool before opening any covers, plates, or plugs.
5. Close the suction and discharge valves.
6. Vent the pump slowly and cautiously.
7. Drain the pump.



This pump is designed to handle most

non-volatile, non-flammable liquids containing specified entrained solids. Do not attempt to pump volatile, corrosive, or flammable liquids which may damage the pump or endanger personnel as a result of pump failure.



Use lifting and moving equipment in good repair and with adequate capacity to prevent injuries to personnel or damage to equipment. Attach lifting equipment to the lifting device fitted to the pump. If chains or cable are wrapped around the pump to lift it, make certain that they are positioned so as not to damage the pump, and so that the load will be balanced. The bail is intended for use in lifting the pump assembly only. Suction and discharge hoses and piping must be removed from the pump before lifting.



After the pump has been installed, make certain that the pump and all piping or hose connections are tight, properly supported and secure before operation.



Do not operate the pump against a closed discharge valve. If operated against a closed discharge valve, pump components will deteriorate, and the liquid could come to a boil, build pressure, and cause the pump casing to rupture or explode. Momentary closure of a discharge valve is acceptable only

when required for startup or shutdown procedures.



Do not remove plates, covers, gauges, pipe plugs, or fittings from an overheated pump. Vapor pressure within the pump can cause parts being disengaged to be ejected with great force. Allow the pump to cool completely before servicing.



This pump may be used to handle materials which could cause illness through direct exposure or emitted fumes. Wear adequate protective clothing when working on the pump or piping.



This pump is equipped with automatic liquid level controls, and is subject to automatic restart. Keep hands and clothing away from the unit to prevent injury during automatic operation. Disconnect the positive battery cable before performing any maintenance. Failure to do so may result in serious personal injury.

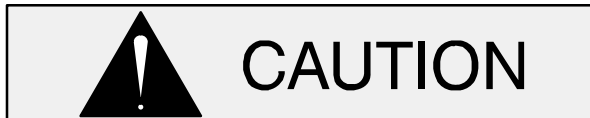

Make sure the pump is level. Lower jack

stands and chock the wheels, if so equipped. Use caution when positioning the skid-mounted unit to prevent damage to the fuel tank.



Do not operate an internal combustion engine in an explosive atmosphere. When operating an internal combustion engine in an enclosed area, make sure exhaust fumes are piped to the outside. These fumes contain carbon monoxide, a deadly gas that is colorless, tasteless and odorless.



Fuel used by internal combustion engines presents an extreme explosion and fire hazard. Make certain that all fuel lines are securely connected and free of leaks. Never refuel a hot or running engine. Avoid overfilling the fuel tank. Always use the correct type of fuel.



Never tamper with the governor to gain more power. The governor establishes safe operating limits that should not be exceeded. Refer to the Performance Curve in Section, Page E-1 for the maximum continuous operating speed for this pump.

INSTALLATION – SECTION B

Review all SAFETY information in Section A.

Since pump installations are seldom identical, this section offers only general recommendations and practices required to inspect, position, and arrange the pump and piping.

Most of the information pertains to a standard **static lift** application where the pump is positioned above the free level of liquid to be pumped.

If installed in a **flooded suction application** where the liquid is supplied to the pump under pressure, some of the information such as mounting, line

configuration, and priming must be tailored to the specific application. Since the pressure supplied to the pump is critical to performance and safety, **be sure** to limit the incoming pressure to 50% of the maximum permissible operating pressure as shown on the pump performance curve.

For further assistance, contact your Gorman-Rupp distributor or the Gorman-Rupp Company.

Pump Dimensions

See Figure 1 for the approximate physical dimensions of this pump.

OUTLINE DRAWING

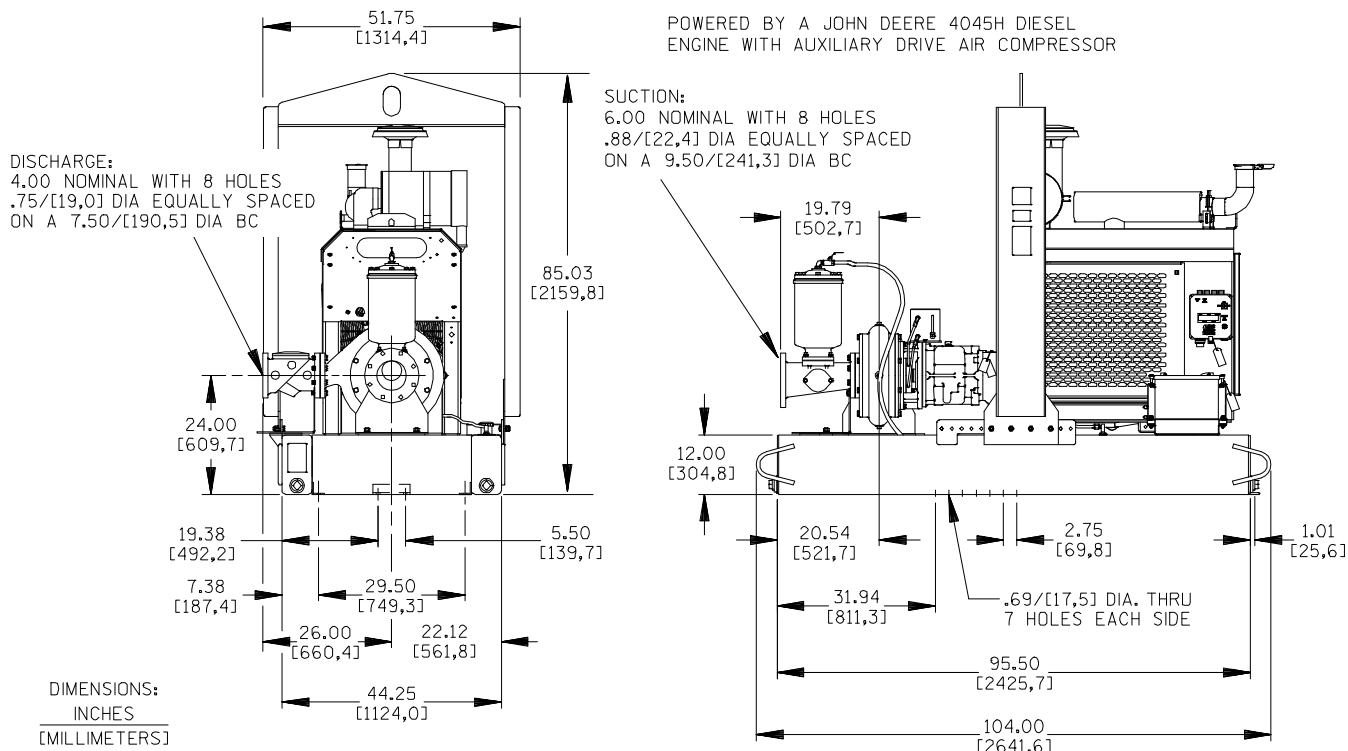

Figure 1. Pump Model PA4C22-4045H

PREINSTALLATION INSPECTION

The pump assembly was inspected and tested before shipment from the factory. Before installation, inspect the pump for damage which may have occurred during shipment. Check as follows:

- a. Inspect the pump for cracks, dents, damaged threads, and other obvious damage.
- b. Check for and tighten loose attaching hardware. Since gaskets tend to shrink after drying, check for loose hardware at mating surfaces.

- c. Carefully read all tags, decals, and markings on the pump assembly, and perform all duties indicated. Note that the pump shaft rotates in the required direction.
- d. Check levels and lubricate as necessary. Refer to **LUBRICATION** in the **Maintenance and Repair Manual** and perform duties as instructed.
- e. If the pump has been stored for more than 12 months, some of the components or lubricants may have exceeded their maximum shelf life. These **must be inspected or replaced** to ensure maximum pump service.

If the maximum shelf life has been exceeded, or if anything appears to be abnormal, contact your Gorman-Rupp distributor or the factory to determine the repair or updating policy. **Do not** put the pump into service until appropriate action has been taken.

Battery Installation

Unless otherwise specified on the pump order, the engine battery is **not** included with engine driven units.

Refer to the information accompanying the battery and/or electrolyte solution for activation and charging instructions.

Before installing the battery, clean the positive and negative cable connectors, and the battery terminals. Secure the battery by tightening the holddown brackets. The terminals and clamps may be coated with petroleum jelly to retard corrosion. Connect and tighten the positive cable first, then the negative cable.

POSITIONING PUMP



Use lifting and moving equipment in good repair and with adequate capacity to prevent injuries to personnel or damage to equipment. Attach lifting equipment to the lifting device fitted to the

pump. If chains or cable are wrapped around the pump to lift it, make certain that they are positioned so as not to damage the pump, and so that the load will be balanced. The bail is intended for use in lifting the pump assembly only. Suction and discharge hoses and piping must be removed from the pump before lifting.

Lifting

Pump unit weights will vary depending on the mounting and drive provided. Check the shipping tag on the unit packaging for the actual weight, and use lifting equipment with appropriate capacity. Drain the pump and remove all customer-installed equipment such as suction and discharge hoses or piping before attempting to lift existing, installed units.



The pump assembly can be seriously damaged if the chains or cables used to lift and move the unit are improperly wrapped around the pump.

Mounting

Locate the pump in an accessible place as close as practical to the liquid being pumped. Level mounting is essential for proper operation. The pump may have to be supported or shimmed to provide for level operation and eliminate vibration.

For engine driven units, the pump **must** be positioned as level as possible to ensure sufficient lubrication and fuel supply to the engine.

If the pump has been mounted on a moveable base, make certain the base is stationary by setting the brake and blocking the wheels before attempting to operate the pump.



If the pump has been mounted on a moveable base, do not attempt to operate the pump unless the unit is level. Be sure

the leveling stands are positioned on a solid surface, and the wheels are chocked.

SUCTION AND DISCHARGE PIPING

Pump performance is adversely effected by increased suction lift, discharge elevation, and friction losses. See the performance curve and operating range shown on Page E-1 to be sure your overall application allows pump to operate within the safe operation range.

Materials

Either pipe or hose may be used for suction and discharge lines; however, the materials must be compatible with the liquid being pumped. If hose is used in suction lines, it must be the rigid-wall, reinforced type to prevent collapse under suction. Using piping couplings in suction lines is not recommended.

Line Configuration

Keep suction and discharge lines as straight as possible to minimize friction losses. Make minimum use of elbows and fittings, which substantially increase friction loss. If elbows are necessary, use the long-radius type to minimize friction loss.

Connections to Pump

Before tightening a connecting flange, align it exactly with the pump port. Never pull a pipe line into place by tightening the flange bolts and/or couplings.

Lines near the pump must be independently supported to avoid strain on the pump which could cause excessive vibration, decreased bearing life, and increased shaft and seal wear. If hose-type lines are used, they should have adequate support to secure them when filled with liquid and under pressure.

SUCTION LINES

To avoid air pockets which could affect pump priming, the suction line must be as short and direct as

possible. When operation involves a suction lift, the line must always slope upward to the pump from the source of the liquid being pumped; if the line slopes down to the pump at any point along the suction run, air pockets will be created.

Fittings

Suction lines should be the same size as the pump inlet. If reducers are used in suction lines, they should be the eccentric type, and should be installed with the flat part of the reducers uppermost to avoid creating air pockets. Valves are not normally used in suction lines, but if a valve is used, install it with the stem horizontal to avoid air pockets.

Strainers

Be certain to use the strainer furnished with the pump; any spherical solids which pass through the strainer will also pass through the pump itself.

If a strainer not furnished with the pump is installed by the pump user, make certain that the total area of the openings in the strainer is at least three or four times the cross section of the suction line, and that the openings will not permit passage of solids larger than the solids handling capability of the pump.

This pump is designed to handle up to 3 inch (76,2 mm) diameter spherical solids.

Sealing

Since even a slight leak will affect priming, head, and capacity, especially when operating with a high suction lift, all connections in the suction line should be sealed with pipe dope to ensure an airtight seal. Follow the sealant manufacturer's recommendations when selecting and applying the pipe dope. The pipe dope should be compatible with the liquid being pumped.

Suction Lines In Sumps

If a single suction line is installed in a sump, it should be positioned away from the wall of the sump at a distance equal to 1 1/2 times the diameter of the suction line.

If there is a liquid flow from an open pipe into the sump, the flow should be kept away from the suction inlet because the inflow will carry air down into the sump, and air entering the suction line will reduce pump efficiency.

If it is necessary to position inflow close to the suction inlet, install a baffle between the inflow and the suction inlet at a distance 1-1/2 times the diameter of the suction pipe. The baffle will allow entrained air to escape from the liquid before it is drawn into the suction inlet.

If two suction lines are installed in a single sump, the flow paths may interact, reducing the efficiency of one or both pumps. To avoid this, position the suction inlets so that they are separated by a distance equal to at least 3 times the diameter of the suction pipe.

Suction Line Positioning

The depth of submergence of the suction line is critical to **efficient** pump operation. Figure 2 shows recommended minimum submergence vs. velocity.

Although not recommended, the vacuum assisted priming feature allows the pump to be operated temporarily in a “slurping” application with varying water levels.

NOTE

The pipe submergence required may be reduced by installing a standard pipe increaser fitting at the end of the suction line. The larger opening size will reduce the inlet velocity. Calculate the required submergence using the following formula based on the increased opening size (area or diameter).

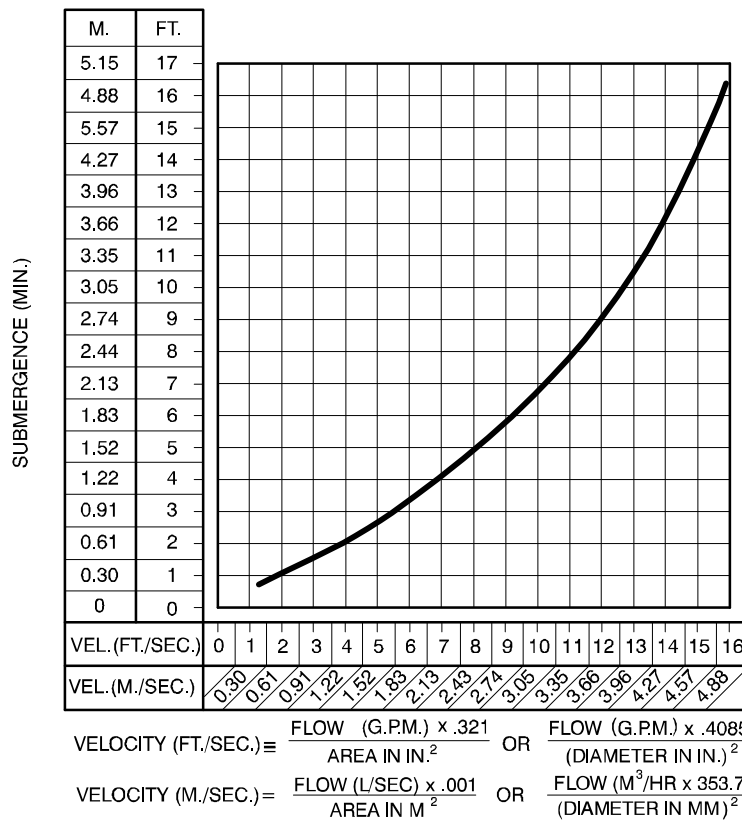

Figure 2. Recommended Minimum Suction Line Submergence vs. Velocity

DISCHARGE LINES

Siphoning

Do not terminate the discharge line at a level lower than that of the liquid being pumped unless a siphon breaker is used in the line. Otherwise, a siphoning action causing damage to the pump could result.

Valves

This pump is designed with a check valve in the discharge line.

If a throttling valve is desired in the discharge line, use a valve as large as the largest pipe to minimize friction losses. Never install a throttling valve in a suction line.

With high discharge heads, it is recommended that a throttling valve be installed in the discharge line to protect the pump from excessive shock pressure and reverse rotation when it is stopped.



If the application involves a high discharge head, gradually close the discharge throttling valve before stopping the pump.

ALIGNMENT

The alignment of the pump and engine is critical for trouble-free mechanical operation. See Section E, **Securing Intermediate And Drive Assembly To Engine** in **MAINTENANCE AND REPAIR**, for details.

AUTO-START

The standard pump is equipped with an auto-start control system which allows the pump to start and stop as the liquid level in the wet well or sump rises and falls.

Refer to the information which follows for installation details for the liquid level sensing system provided with your pump.

Float Switch Installation

The Float Switch autostart system employs either a single or double float switch, where a bulb raises or lowers (floats) with the liquid level, thus activating an enclosed miniature switch. The floats are equipped with a socket type connector that plugs into a matching receptacle on the auto-start control box.

Standard floats are equipped with 50 feet (15,2 m) of cable.

When installing the floats, note the following:

- a. **Be sure** to provide sufficient room in the wet well or sump so that floats do not get obstructed or drawn into the suction line. If a flexible suction hose is used, it may be extended to lay along the bottom of the wet well or sump and the float can be attached to the hose above the point where it bends along the bottom. Direct the suction line toward the flow, and the float(s) away from the flow. If a standpipe is available, attach the float switch cable to the standpipe in the sump at the approximate desired liquid level.
- b. In a single float system, the cable can be tethered to the suction line or standpipe approximately 6 inches (152 mm) above the float. This setting allows approximately 9 inches (229 mm) of liquid rise between pump start/stop. The start/stop interval may be increased by extending the float end of the cable. The liquid level in the sump will increase approximately 8 inches (203 mm) between start/stop intervals for every 6 inches (152 mm) of cable increase.
- c. If a double float switch system is used, position the “Start” float at the desired high water level in the sump, and the “Stop” float at the desired low water level in the pump.
- d. Refer to Figure 3 for additional float switch data.

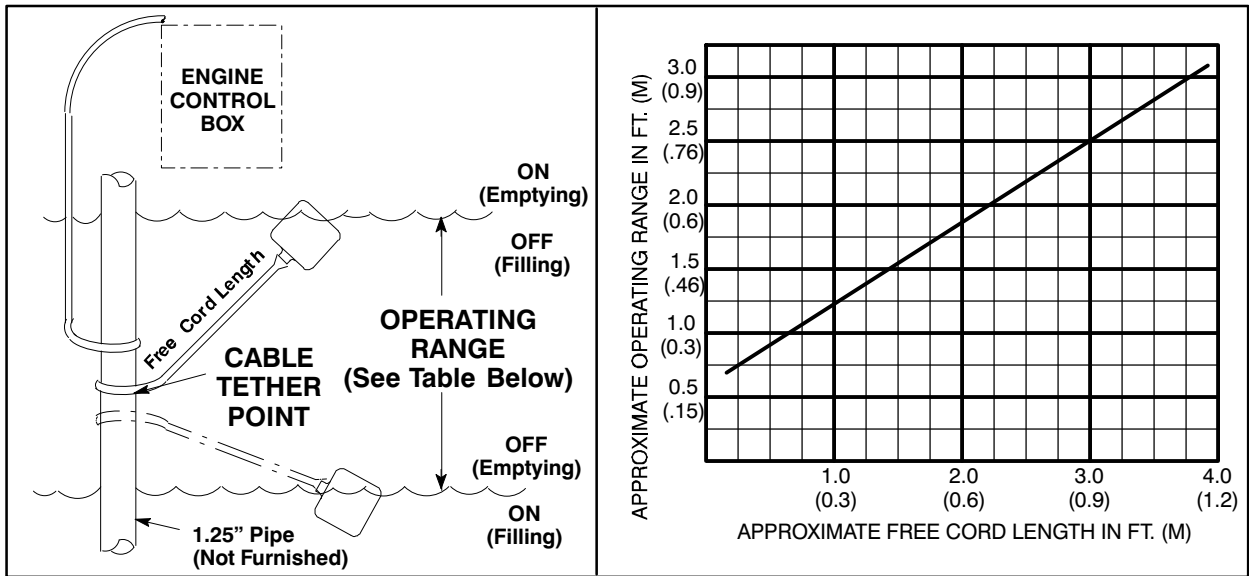

Figure 3. Float Switch Data

OPERATION – SECTION C

Review all **SAFETY** information in Section A.

Follow the instructions on all tags, labels and decals attached to the pump.



Do not operate an internal combustion engine in an explosive atmosphere. When operating an internal combustion engine in an enclosed area, make sure exhaust fumes are piped to the outside. These fumes contain carbon monoxide, a deadly gas that is colorless, tasteless and odorless.

OPERATION



This pump is designed to handle most non-volatile, non-flammable liquids containing specified entrained solids and corrosives. Do not attempt to pump volatile, corrosive, or flammable liquids which may damage the pump or endanger personnel as a result of pump failure.



Pump speed and operating condition points must be within the continuous performance range shown on the performance curve in Section E on page E-1.

PRIMING

Install the pump and piping as described in **INSTALLATION**. Make sure that the piping connections are tight, and that the pump is securely mounted. Check that the pump is properly lubri-

cated (see **LUBRICATION** in **MAINTENANCE AND REPAIR**).

The pump will begin to prime upon startup. The air in the suction line will be discharged from the educator discharge line. Complete priming is indicated by a positive discharge pressure reading.

If full priming is not achieved, the discharge check valve may be malfunctioning. If this occurs, shut down the pump and consult **Maintenance and Repair**, Section E for further details.

STARTING

Check the fuel level and oil levels in the engine, air compressor, pump bearings and seal housing.

Make sure the pump is level. Lower the jack stands and chock the wheels, if so equipped.

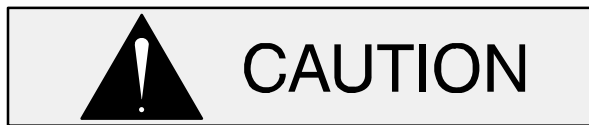

Make sure the pump is level. Lower jack stands and chock the wheels, if so equipped. Use caution when positioning the skid-mounted unit to prevent damage to the fuel tank.



This pump is equipped with automatic liquid level controls, and is subject to automatic restart. Keep hands and clothing away from the unit to prevent injury during automatic operation. Disconnect the positive battery cable before performing any maintenance. Failure to do so may result in serious personal injury.

Consult the engine operations manual before attempting to start the unit.

Manual Starting

On initial start-up, set the engine speed at in the half-throttle position. Turn the keyswitch to 'MANU-

AL'. After the engine starts and the unit is fully primed, adjust the engine RPM until the desired flow rate is achieved.

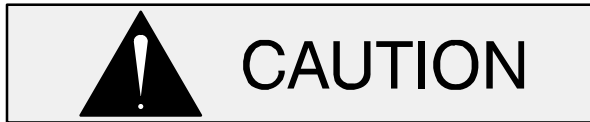

Pump speed and operating condition points must be within the continuous performance range shown on the curve on Page E-1.

Automatic Starting

With the float system installed, follow the procedures outlined for manual starting and throttle adjustment. Switch the keyswitch to 'OFF' until the water level rises above the on point for the float system, then turn the keyswitch to the 'AUTO' setting. The unit will run until the float signals the control that the water in the wet well is at the float off point, at which time the unit will shut down automatically. When the float signals the control that the water in the wet well is at the float on point, the unit will restart automatically, repeating the cycle.

OPERATION

Leakage

Once the pump is fully primed, no leakage should be visible at pump mating surfaces, or at pump connections or fittings. Keep all line connections and fittings tight to maintain maximum pump efficiency.

Pump Vacuum Check

Read the vacuum gauge with the pump primed and at operation speed. Shut off the pump. The vacuum gauge reading will immediately drop proportionate to static suction lift, and should then stabilize. If the vacuum reading falls off rapidly after stabilization, an air leak exists. Before checking for the source of the leak, check the point of installation of the vacuum gauge.

Liquid Temperature And Overheating

The **maximum** liquid temperature for this pump is 160° F (71° C). Do not apply it at a higher operating temperature.

Overheating can occur if operated with the valves in the suction or discharge lines closed. Operating against closed valves could bring the liquid to a boil, build pressure, and cause the pump to rupture or explode. If overheating occurs, stop the pump immediately and allow it to completely cool before servicing it. **Approach any over-heated pump cautiously.**



Allow an over-heated pump to completely cool before servicing. Do not remove plates, covers, gauges, or fittings from an overheated pump. Liquid within the pump can reach boiling temperatures, and vapor pressure within the pump can cause parts being disengaged to be ejected with great force. After the pump cools, drain the liquid from the pump by removing the casing drain plug. Use caution when removing the plug to prevent injury to personnel from hot liquid.

As a safeguard against rupture or explosion due to heat, this pump is equipped with a pressure relief valve which will open if vapor pressure within the pump casing reaches a critical point. If overheating does occur, stop the pump immediately and allow it to cool before servicing it. **Approach any over-heated pump cautiously.** It is recommended that the pressure relief valve assembly be replaced at each overhaul, or any time the pump casing over-heats and activates the valve. **Never** replace this valve with a substitute which has not been specified or provided by the Gorman-Rupp Company.

Strainer Check

Check the strainer regularly, and clean it as necessary. The strainer should also be checked if pump flow rate begins to drop. Monitor and record the

vacuum suction gauge readings regularly to detect strainer blockage.

Never introduce air or steam pressure into the pump casing or piping to remove a blockage. This could result in personal injury or damage to the equipment. If backflushing is absolutely necessary, **liquid pressure** must be limited to 50% of the maximum permissible operating pressure shown on the pump performance curve.

STOPPING

Never halt the flow of liquid suddenly. If the liquid being pumped is stopped abruptly, damaging shock waves can be transmitted to the pump and piping system. Close all connecting valves slowly.

Reduce the throttle speed slowly and allow the engine to idle briefly before stopping.

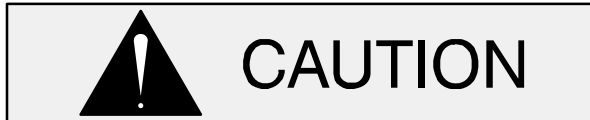

If the application involves a high discharge head, gradually close the discharge throttling valve before stopping the pump.

After stopping the pump, switch off the engine ignition and remove the key to ensure that the pump will remain inoperative.

BEARING TEMPERATURE CHECK

Bearings normally run at higher than ambient temperatures because of heat generated by friction. Temperatures up to 160°F (71°C) are considered

normal for bearings, and they can operate safely to at least 180°F (82°C).

Checking bearing temperatures by hand is inaccurate. Bearing temperatures can be measured accurately by placing a contact-type thermometer against the housing. Record this temperature for future reference.

A sudden increase in bearing temperatures is a warning that the bearings are at the point of failing to operate properly. Make certain that the bearing lubricant is of the proper viscosity and at the correct level (see **LUBRICATION** in the Maintenance and Repair Manual). Bearing overheating can also be caused by shaft misalignment and/or excessive vibration.

When pumps are first started, the bearings may seem to run at temperatures above normal. Continued operation should bring the temperatures down to normal levels.

Cold Weather Preservation

In below freezing conditions, drain the pump to prevent damage from freezing. Also, clean out any solids by flushing with a hose. Operate the pump for approximately one minute; this will remove any remaining liquid that could freeze the pump rotating parts. If the pump will be idle for more than a few hours, or if it has been pumping liquids containing a large amount of solids, drain the pump, and flush it thoroughly with clean water. To prevent large solids from clogging the drain port and preventing the pump from completely draining, insert a rod or stiff wire in the drain port, and agitate the liquid during the draining process. Clean out any remaining solids by flushing with a hose.

TROUBLESHOOTING – SECTION D

Review all SAFETY information in Section A.



Before attempting to open or service the pump:

1. Familiarize yourself with this manual.
2. Shut down the engine and disconnect the positive battery cable and take precautions to ensure that the pump will remain inoperative.
3. Allow the pump to completely cool if overheated.
4. Check the temperature and make sure pump is cool before opening any covers, plates, or plugs.
5. Close the suction and discharge valves.
6. Vent the pump slowly and cautiously.
7. Drain the pump.

TROUBLE	POSSIBLE CAUSE	PROBABLE REMEDY
PUMP FAILS TO PRIME	Discharge check valve contaminated, damaged, or unable to seat. Air compressor head 180° out. Air leak in suction line. Lining of suction hose collapsed. Leaking or worn seal or pump gasket. Suction lift or discharge head too high. Air compressor damaged or belts broken. Strainer clogged.	Clean or replace check valve. Consult factory. Correct leak. Replace suction hose. Check pump vacuum. Replace leaking or worn seal or gasket. Check piping installation and install bypass line if needed. See INSTALLATION . Check and repair/replace. Check strainer and clean if necessary.
PUMP STOPS OR FAILS TO DELIVER RATED FLOW OR PRESSURE	Eductor clogged. Air leak in suction line. Lining of suction hose collapsed. Leaking or worn seal or pump gasket.	Check and clean eductor. Correct leak. Replace suction hose. Check pump vacuum. Replace leaking or worn seal or gasket.

TROUBLE	POSSIBLE CAUSE	PROBABLE REMEDY
PUMP STOPS OR FAILS TO DELIVER RATED FLOW OR PRESSURE (cont.)	<p>Strainer clogged.</p> <p>Discharge check valve clogged.</p> <p>Suction intake not submerged at proper level or sump too small.</p> <p>Impeller or other wearing parts worn or damaged.</p> <p>Impeller clogged.</p> <p>Discharge head too high.</p> <p>Suction lift too high.</p> <p>Pump speed too slow.</p> <p>Belt or flexible coupling broken.</p>	<p>Check strainer and clean if necessary.</p> <p>Check and clean check valve.</p> <p>Check installation and correct submergence as needed.</p> <p>Replace worn or damaged parts. Check that impeller is properly centered and rotates freely.</p> <p>Free impeller of debris.</p> <p>Install bypass line.</p> <p>Measure lift w/vacuum gauge. Reduce lift and/or friction losses in suction line.</p> <p>Check engine output; consult engine operation manual.</p> <p>Check and replace as necessary.</p>
PUMP REQUIRES TOO MUCH POWER	<p>Pump speed too high.</p> <p>Extreme ambient temperature.</p> <p>Discharge head too low.</p> <p>Fuel filter clogged.</p> <p>Liquid solution too thick.</p> <p>Fuel contaminated.</p> <p>Pump or jack shaft bearing(s) frozen.</p>	<p>Check engine output.</p> <p>Reduce pump output.</p> <p>Adjust discharge valve.</p> <p>Check & replace often in extreme operating conditions.</p> <p>Dilute if possible.</p> <p>Check and replace as required.</p> <p>Disassemble, check and replace bearing(s) as required..</p>
PUMP CLOGS FREQUENTLY	<p>Discharge flow too slow.</p> <p>Suction check valve or foot valve clogged or binding.</p> <p>Liquid solution too thick.</p>	<p>Open discharge valve fully to increase flow rate, and run engine at maximum governed speed.</p> <p>Clean valve.</p> <p>Dilute if possible.</p>
EXCESSIVE NOISE	<p>Cavitation in pump.</p> <p>Pumping entrained air.</p> <p>Pump or drive not securely mounted.</p> <p>Impeller clogged or damaged.</p>	<p>Reduce suction lift and/or friction losses in suction line. Record vacuum and pressure gauge readings and consult local representative or factory.</p> <p>Locate and eliminate source of air bubble.</p> <p>Secure mounting hardware.</p> <p>Clean out debris; replace damaged parts.</p>

TROUBLE	POSSIBLE CAUSE	PROBABLE REMEDY
BEARINGS RUN TOO HOT	<p>Bearing temperature is high, but within limits.</p> <p>Low or incorrect lubricant.</p> <p>Suction and discharge lines not properly supported.</p> <p>Drive misaligned.</p> <p>Excessive tension on drive belt.</p>	<p>Check bearing temperature regularly to monitor any increase.</p> <p>Check for proper type and level of lubricant.</p> <p>Check piping installation for proper support.</p> <p>Align drive properly.</p> <p>Check belt tension. Adjust as required.</p>

PREVENTIVE MAINTENANCE

Since pump applications are seldom identical, and pump wear is directly affected by such things as the abrasive qualities, pressure and temperature of the liquid being pumped, this section is intended only to provide general recommendations and practices for preventive maintenance. Regardless of the application however, following a routine preventive maintenance schedule will help assure trouble-free performance and long life from your Gorman-Rupp pump. For specific questions concerning your application, contact your Gorman-Rupp distributor or the Gorman-Rupp Company.

Record keeping is an essential component of a good preventive maintenance program. Changes in suction and discharge gauge readings (if so

equipped) between regularly scheduled inspections can indicate problems that can be corrected before system damage or catastrophic failure occurs. The appearance of wearing parts should also be documented at each inspection for comparison as well. Also, if records indicate that a certain part (such as the seal) fails at approximately the same duty cycle, the part can be checked and replaced before failure occurs, reducing unscheduled down time.

For new applications, a first inspection of wearing parts at 250 hours will give insight into the wear rate for your particular application. Subsequent inspections should be performed at the intervals shown on the chart below. Critical applications should be inspected more frequently.

Preventive Maintenance Schedule					
Item	Service Interval*				
	Daily	Weekly	Monthly	Semi-Annually	Annually
General Condition (Temperature, Unusual Noises or Vibrations, Cracks, Leaks, Loose Hardware, Etc.)	I				
Pump Performance (Gauges, Speed, Flow)	I				
Bearing Lubrication				I	
Seal Lubrication (And Packing Adjustment, If So Equipped)		I		R	
V-Belts (If So Equipped)			I		
Air Release Valve Plunger Rod (If So Equipped)			I	C	
Front Impeller Clearance (Wear Plate)				I	
Rear Impeller Clearance (Back Plate)				I	
Check Valve					I
Pressure Relief Valve (If So Equipped)					C
Pump and Driver Alignment					I
Shaft Deflection					I
Bearings				I	
Bearing Housing				I	
Piping					I
Driver Lubrication – See Mfgr's Literature					
<p>Legend:</p> <p>I = Inspect, Clean, Adjust, Repair or Replace as Necessary</p> <p>C = Clean</p> <p>R = Replace</p> <p>* Service interval based on an intermittent duty cycle equal to approximately 4000 hours annually. Adjust schedule as required for lower or higher duty cycles or extreme operating conditions.</p>					

PUMP MAINTENANCE AND REPAIR – SECTION E

MAINTENANCE AND REPAIR OF THE WEARING PARTS OF THE PUMP WILL MAINTAIN PEAK OPERATING PERFORMANCE.

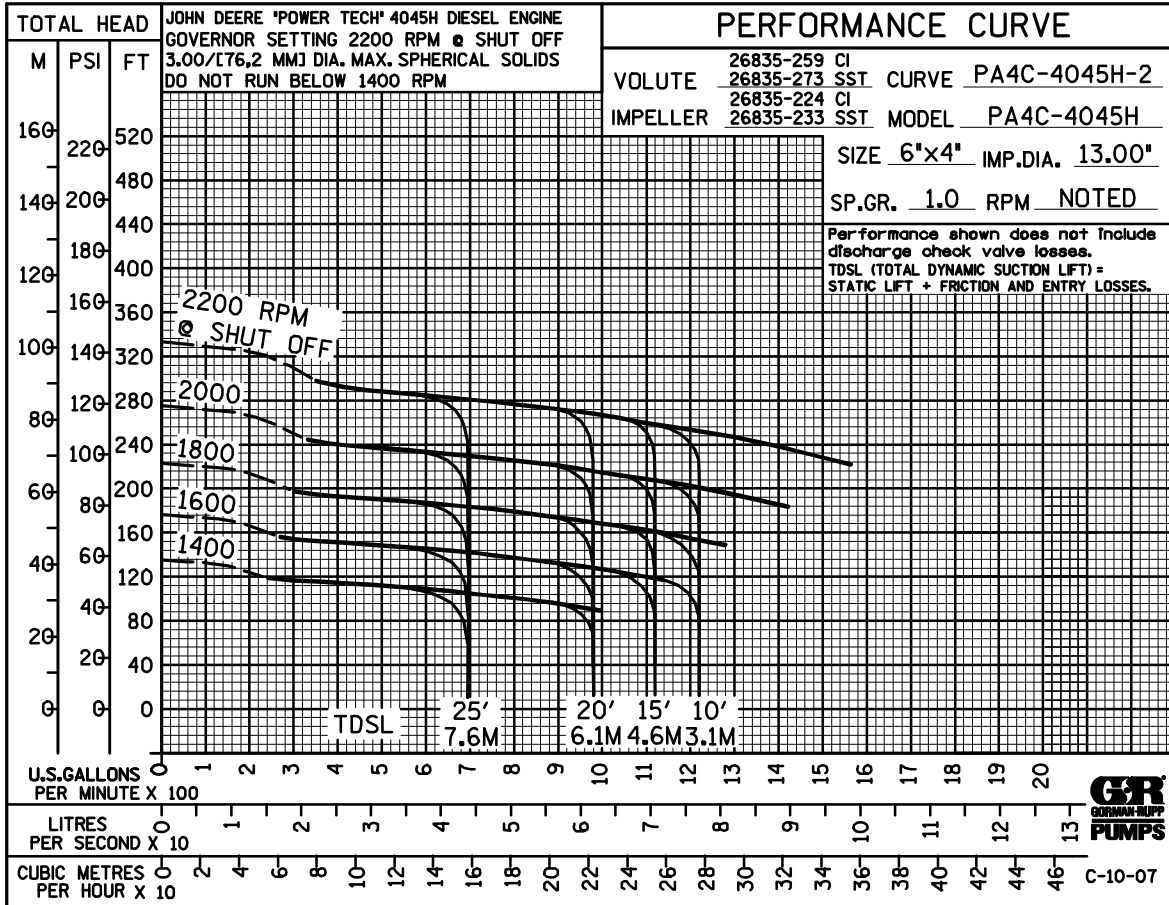

* STANDARD PERFORMANCE FOR PUMP MODEL PA4C22-4045H

*Based on 70°F (21°C) clear water at sea level with minimum suction lift. Since pump installations are seldom identical, your performance may be different due to such factors as viscosity, specific gravity, elevation, temperature, and impeller trim.

Contact the Gorman-Rupp Company to verify performance or part numbers.

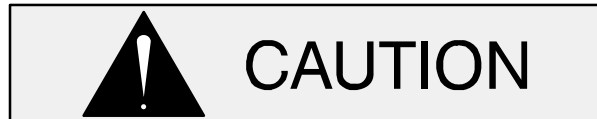

CAUTION

Pump speed and operating condition points must be within the continuous performance range shown on the curve.

If your pump serial number is followed by an "N", your pump is **NOT** a standard production model.

SECTION DRAWING

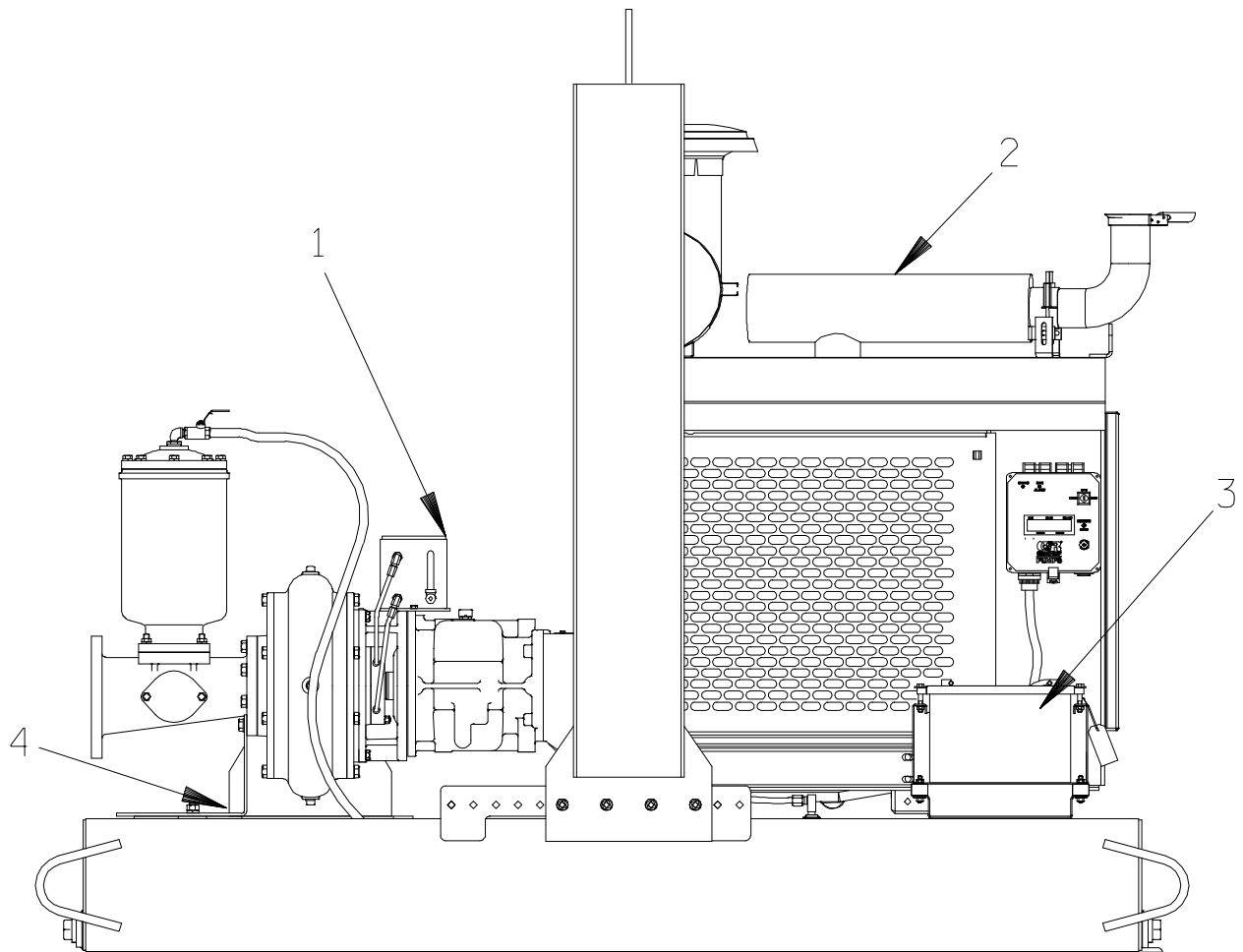

Figure 1. Pump Model PA4C22-4045H

PARTS LIST
Pump Model PA4C22-4045H
 (From S/N 1477675 Up)

ITEM NO.	PART NAME	PART NUMBER	MAT'L CODE	QTY
1	PUMP END ASSEMBLY	PA4C22-(SAE 4/10)---		1
2	POWER UNIT KIT	46143-115	---	1
3	BATTERY	SEE OPTIONS		REF
4	PUMP MOUNTING KIT	48157-006	---	1
NOT SHOWN:				
	SAE 3/10 BELLHOUSING ADAPTOR RING	3093	15080	1
	PRIME AIRE DECAL	38812-078	---	2
	G-R DECAL	GR-06	---	3
	CAUTION DECAL	2613FJ	---	1
	WARNING DECAL	2613FE	---	1
OPTIONAL:				
	WHEEL KIT	GRP30-272	---	1
	DRY BATTERY	29331-517	---	1
	WET BATTERY	29331-527	---	1
	EPS W/TRANSDUCER AUTO CONT PANEL	48122-545	---	1
	NPT THREADED SUCT FLANGE KIT	48274-211	---	1
	NPT THREADED DISCH FLANGE KIT	48274-210	---	1

SECTION DRAWING

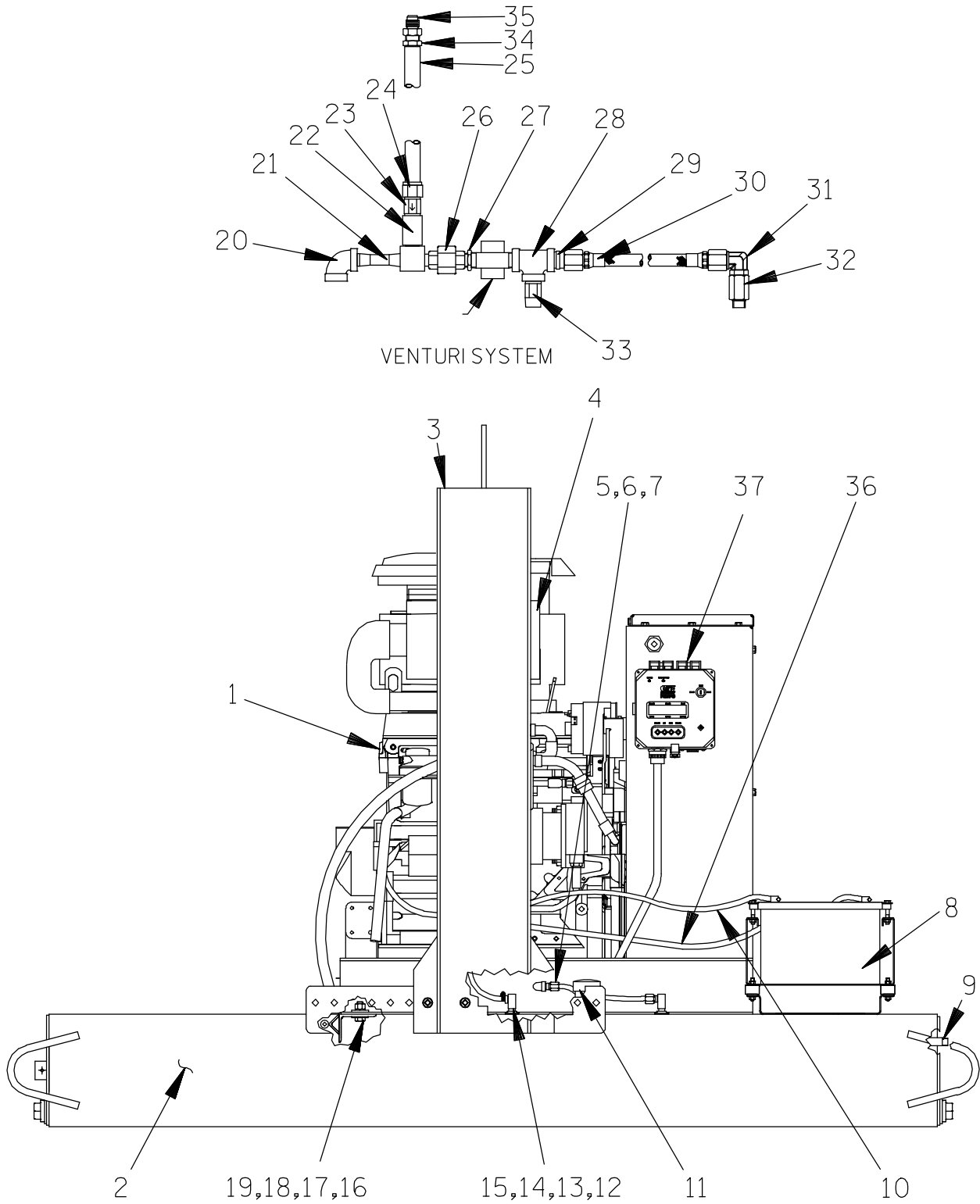

Figure 2. 46143-115 Power Unit Kit

PARTS LIST
46143-115 Power Unit Kit

ITEM NO.	PART NAME	PART NUMBER	MAT'L CODE	QTY	ITEM NO.	PART NAME	PART NUMBER	MAT'L CODE	QTY
1	J.D. 4045H ENGINE	29224-371	----	1	25	.50 ID x 60 IN. LG HOSE	18513-113	----	1
2	BASE/FUEL TANK	41553-007	24150	1	26	PIPE UNION	AH12	11999	1
3	LIFTING BAIL KIT	48274-804	----	1	27	RED PIPE BUSHING	AP1208	15079	1
4	MUFFLER GRD ASSY	NOT REQUIRED		1	28	PIPE TEE	U08	11999	1
5	MALE ELBOW	26351-131	----	1	29	CONNECTOR	26351-065	----	2
6	CONNECTOR	S1447	----	2	30	HOSE ASSEMBLY	46341-426	----	1
7	HOSE ASSEMBLY	46341-789	----	1	31	MALE ELBOW	26341-310	----	1
8	BATTERY BOX KIT	42432-005	----	1	32	HEX ADAPTOR	26523-188	----	1
9	OIL DRAIN ASSY	46342-013	----	1	33	PRESSURE RELIEF VALVE	26662-028	----	1
10	POS BATT CABLE	47311-109	----	1	34	HOSE BARB FITTING	26523-047	----	1
11	GAUGE	29332-135	----	1	31	CONNECTOR	S1598	----	1
12	FUEL PICKUP	29332-145	----	2	34	NEG. BATTERY CABLE	47311-172	----	1
13	HOSE BARB FITTING	26523-386	----	2	37	CONTROL PANEL	48122-544	----	1
14	HOSE	11308G	----	1	NOT SHOWN:				
15	HOSE CLAMP	26518-641	----	1		ENGINE STARTUP TAG	38816-269	----	1
16	HEX HD CAPSCREW	B1007	----	4		WARNING DECAL	38816-203	----	4
17	HEX NUT	D10	15991	4		INSTRUCTION DECAL	38818-144	----	1
18	LOCK WASHER	J10	15991	4		WARNING DECAL	38816-132	----	2
19	FLAT WASHER	K10	15991	4		FLOAT SWITCH KIT	48312-980	----	2
20	PIPE ELBOW	R16	11999	1	OPTIONAL:				
21	VENTURI	26817-001	----	1		HEATED FUEL FILTER KIT	48122-914	----	1
22	REDUCING ELBOW	AE1608	15079	1		DUAL FLOAT SWITCH KIT	48312-981	----	1
23	CHECK VALVE	26641-092	----	1					
24	HOSE BARB FITTING	26523-446	----	1					

SECTION DRAWING

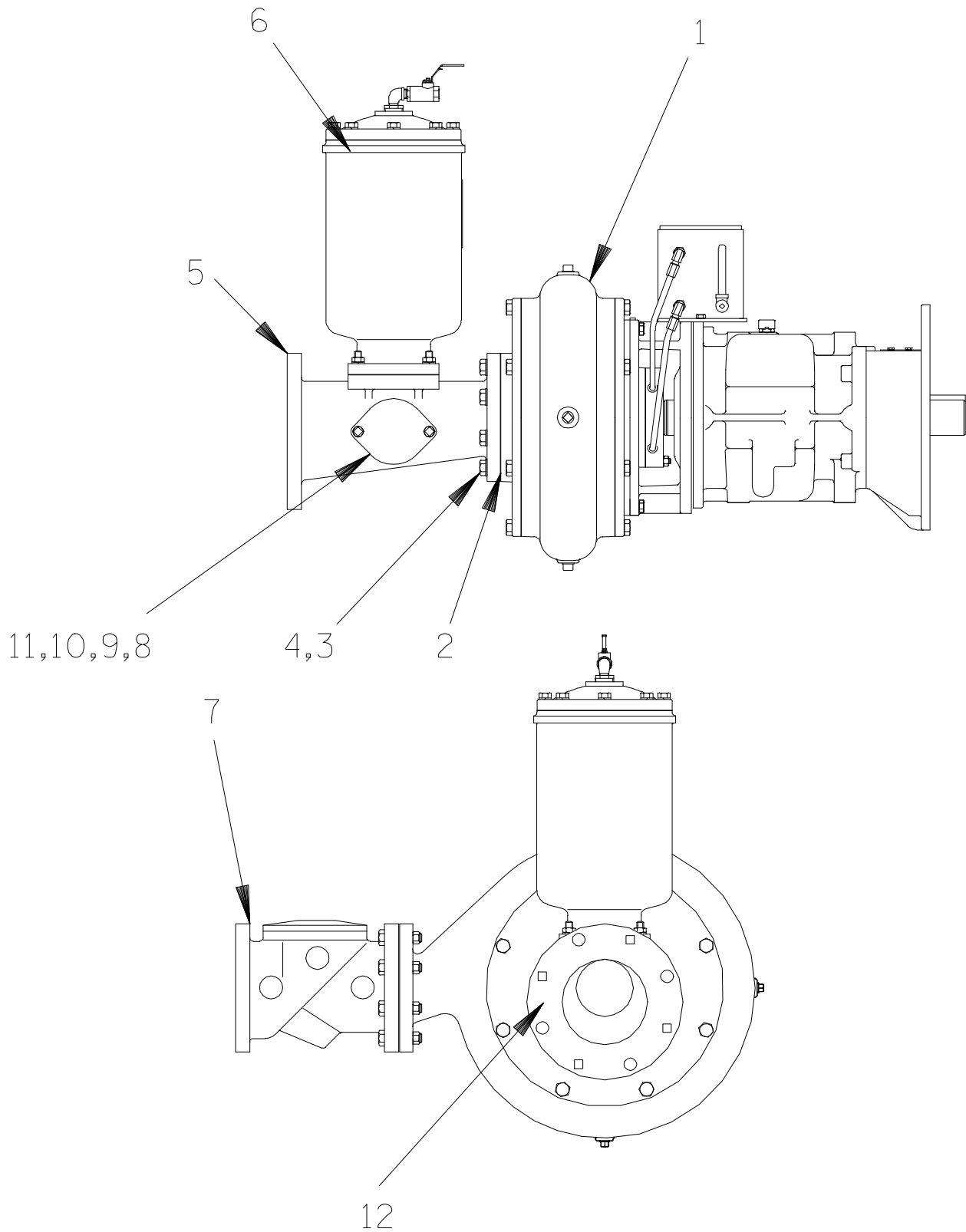

Figure 3. PA4C22-(SAE 4/10) Pump End Assembly

PARTS LIST
PA4C22--(SAE 4/10) Pump End Assembly

ITEM NO.	PART NAME	PART NUMBER	MAT'L CODE	QTY
1	PUMP ASSEMBLY	CONSULT FACTORY		1
2	GASKET	25113-034	----	1
3	* HEX HD CAPSCREW	B1008	17090	8
4	LOCK WASHER	J10	17090	8
5	SUCTION SPOOL	38644-806	17040	1
6	PRIMING CHAMBER KIT	48275-008	----	1
7	4" CHECK VALVE KIT	48274-022	----	1
	-CHECK VALVE	26642-301	----	1
	* -FLAPPER	26688-019	----	1
	* -COVER GASKET	26688-006	----	1
	* -FLANGE GASKET	1676G	19410	1
8	COVER PLATE	38244-021	17040	1
9	GASKET	38689-037	19410	1
10	HEX HD CAPSCREW	B0804	17090	2
11	LOCK WASHER	J08	17090	2
12	PIPE PLUG	P04	17090	1
NOT SHOWN:				
	STRAINER ASSEMBLY	7823A	24000	1
	NAME PLATE	2613R	13000	1
	DRIVE SCREW	BM#04-03	17000	2
	DRIVE ASSEMBLY	44162-164	----	1
	G-R DECAL	GR-06	----	1
	SUCTION STICKER	6588AG	----	1
	DISCHARGE STICKER	6588BJ	=====	1
	WARNING DECAL	2613FE	----	1
	OIL LEVEL DECAL	38816-123	----	1
	OIL LEVEL DECAL	2613FP	----	1
	LUBE DECAL	26836-925	----	1
	GUARD WARNING STICKER	38816-063	----	1

* INDICATES PARTS RECOMMENDED FOR STOCK

NOTE: 3093 15080 SAE 3/10 ADAPTOR RING REQUIRED FOR SAE 3/10 BELLHOUSING APPLICATIONS

SECTION DRAWING

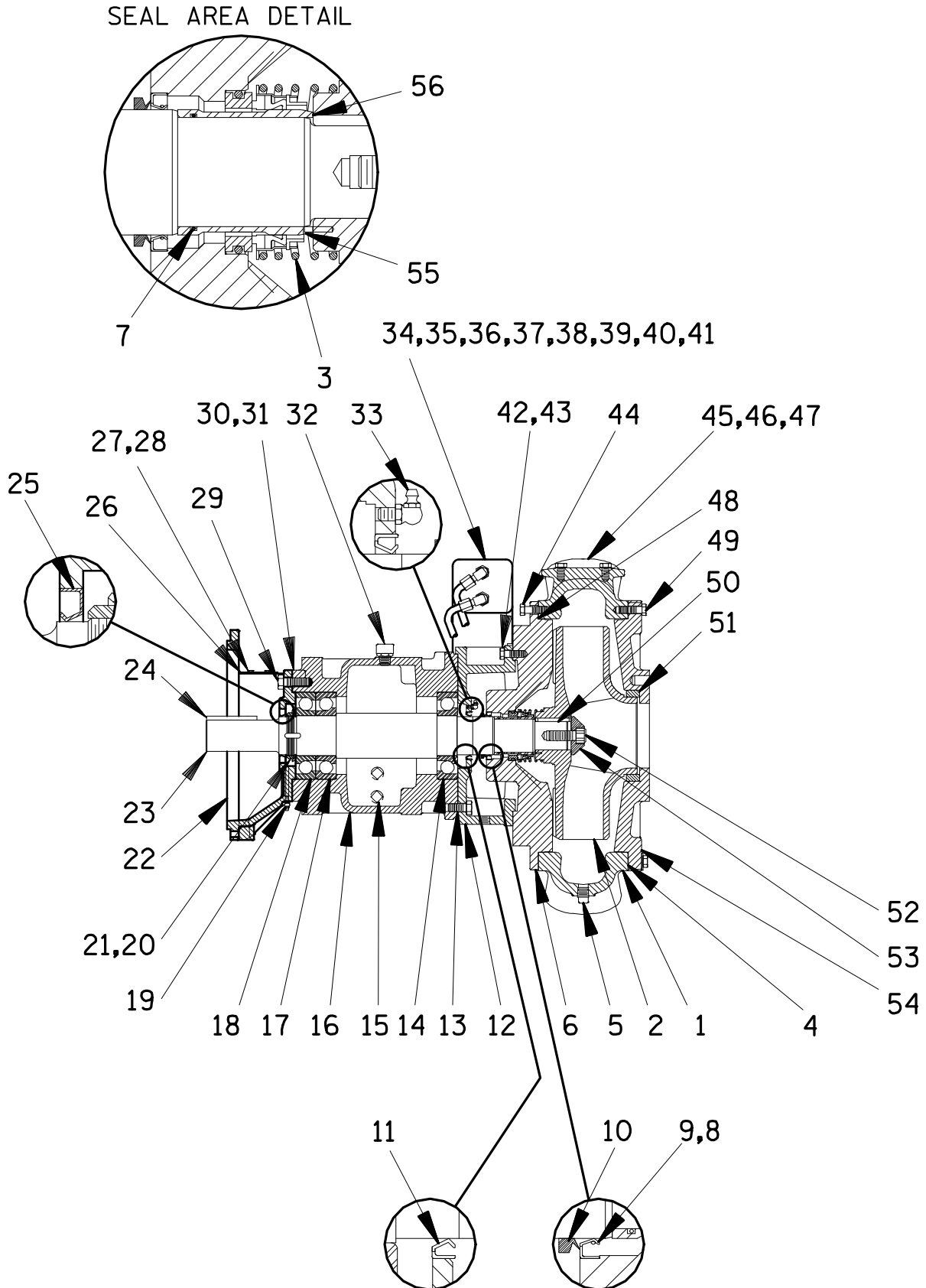

Figure 4. Pump Assembly

PARTS LIST

Pump Assembly

ITEM NO.	PART NAME	PART NUMBER	MAT'L CODE	QTY	ITEM NO.	PART NAME	PART NUMBER	MAT'L CODE	QTY
1	PUMP CASING	26835-273	----	1	30 *	BEARING SHIM	26835-973	----	3
2	IMPELLER	26835-233	----	1	31 *	BEARING SHIM	26835-974	----	1
3 *	MECHANICAL SEAL	26835-554	----	1	32	BREATHER VENT	26717-007	----	1
4 *	SUCTION COVER GASKET	26835-906	----	1	33	GREASE FITTING	26836-915	----	1
5	PIPE PLUG	P08	17090	5	34	MALE CONNECTOR	26351-059	----	2
6	BACK PLATE	26835-365	----	1	35	CONNECTOR	26351-060	----	2
7 *	O-RING	25152-138	----	1	36	HOSE END	26523-015	----	4
8 *	LIP SEAL	26835-805	----	1	37	.37 I.D. X 24" LG HOSE	18513-302	----	2
9 *	LIP SEAL SPRING	26835-796	----	1	38	BREATHER VENT	26717-007	----	1
10 *	V-RING	26835-582	----	1	39	REDUCING BUSHING	AP1608	17040	1
11 *	LIP SEAL	26835-804	----	1	40	SEAL LUBE RESERVOIR	26835-713	----	1
12	BRACKET	26835-523	----	1	41	VIEW GAUGE	26836-887	----	2
13	HEX HD CAPSCREW	B1008	15991	4	42	HEX HD CAPSCREW	B1006	17090	8
14 *	BALL BEARING	26836-934	----	1	43	HEX HD CAPSCREW	B0107	17090	2
15	PIPE PLUG	P08	15079	2	44	HEX HD CAPSCREW	B0806	17090	8
16	FRAME	26835-601	----	1	45	CLEAN OUT COVER	26835-411	----	1
17 *	BALL BEARING	23413-216	----	1	46 *	O-RING	25152-339	----	1
18 *	BALL BEARING	23413-216	----	1	47	HEX HD CAPSCREW	B0804	15991	4
19	GREASE FITTING	26836-914	----	1	48 *	PUMP CASING GASKET	26835-906	----	1
20	BRG LOCK WASHER	23962-517	----	1	49	HEX HD CAPSCREW	B1006	15991	8
21	BRG LOCK NUT	23962-017	----	1	50 *	IMPELLER KEY	N0810-1/2	15990	1
22	BRACKET	26835-525	----	1	51 *	WEAR RING	26835-321	----	1
23 *	IMPELLER SHAFT	26853-454	----	1	52 *	IMP LOCK SCREW KIT	26835-824	----	1
24 *	SHAFT KEY	N1020	15991	1	53	IMPELLER WASHER	26835-964	----	1
25 *	LIP SEAL	26835-804	----	1	54	SUCTION COVER	26835-509	----	1
26	COVER	26835-673	----	1	55 *	SHAFT SLEEVE	26835-488	----	1
27	HEX HD CAPSCREW	B0402	15991	4	56 *	IMPELLER SHIM	26835-977	----	3
28	FLAT WASHER	KE04	15991	4	NOT SHOWN:				
29	HEX HD CAPSCREW	B1007	15991	4		LUBRICATION TAG	26836-925	----	1

* INDICATES PARTS RECOMMENDED FOR STOCK

SECTION DRAWING

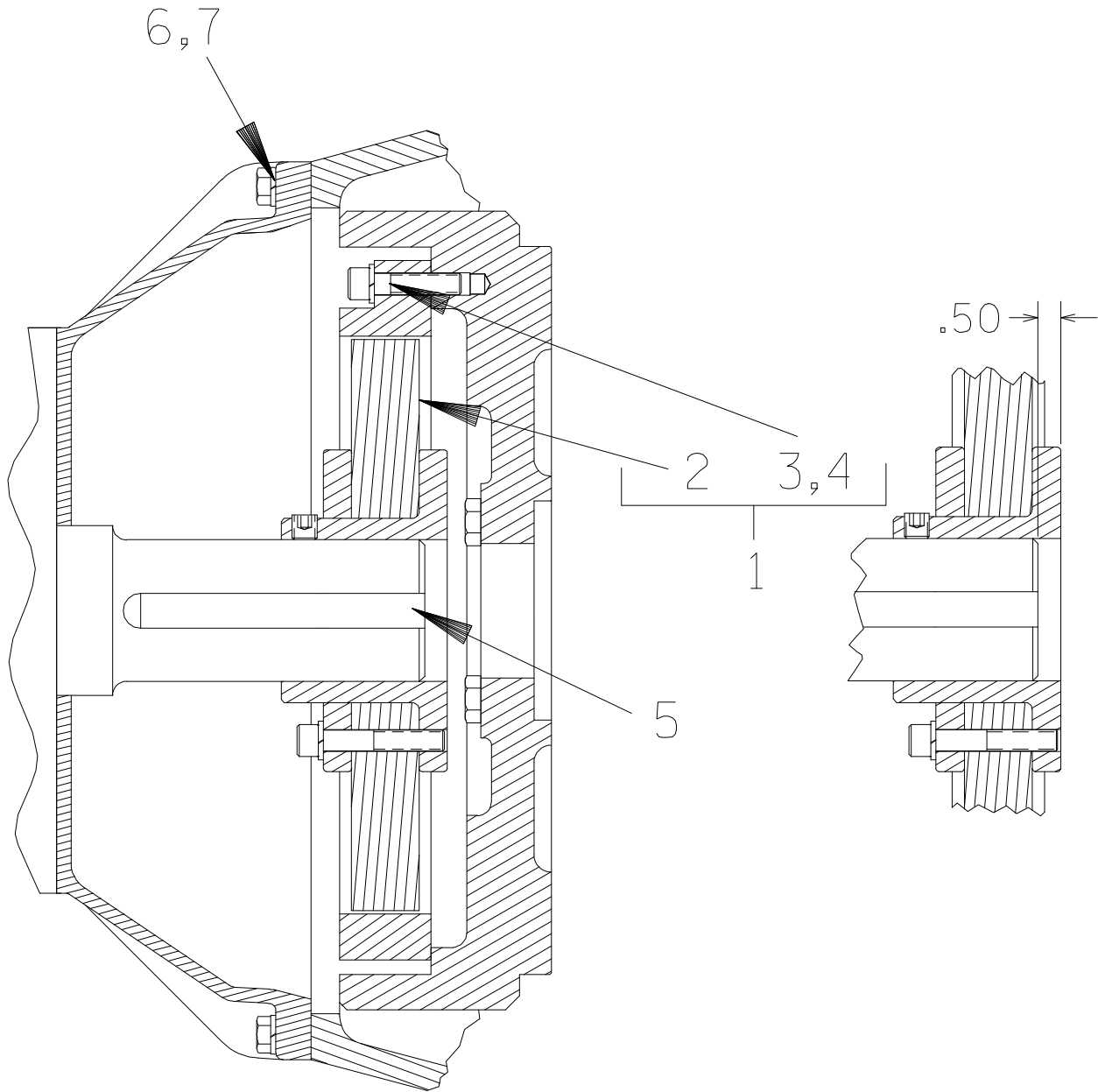

Figure 5. 44162-164 Drive Assembly

ITEM NO.	PART NAME	PART NUMBER	MAT'L CODE	QTY
1	COUPLING KIT	48112-008	---	1
2	-COUPLING ASSEMBLY	24391-112	---	1
3	-LOCKWASHER	J06	15991	8
4	-SOCKET HEAD CAPSCREW	BD0606-1/2	15991	8
5	KEY	N1020	15991	REF
6	HEX HEAD CAPSCREW	22645-164	---	12
7	LOCKWASHER	21171-511	---	12

SECTION DRAWING

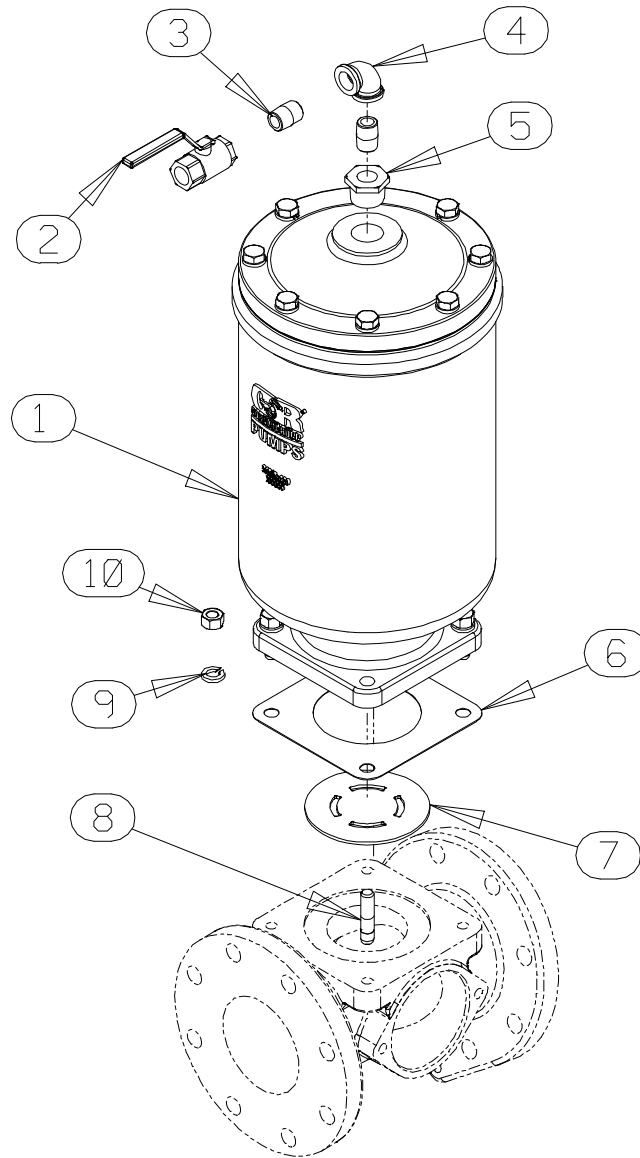

Figure 6. 48275-008 Priming Chamber Kit

ITEM NO.	PART NAME	PART NUMBER	MAT'L CODE	QTY
1	PRIMING CHAMBER ASSY	46112-711	---	1
2	BALL VALVE	26631-114	---	1
3	CLOSE PIPE NIPPLE	T08	17040	2
4	PIPE ELBOW	R08	17040	1
5	REDUCER PIPE BUSHING	AP1608	17040	1
6	* GASKET	38687-053	19060	1
7	BAFFLE	31113-011	17040	1
8	STUD	C0809	1706G	4
9	LOCK WASHER	J08	17090	4
10	HEX NUT	D08	17050	4

* INDICATES PARTS RECOMMENDED FOR STOCK

SECTION DRAWING

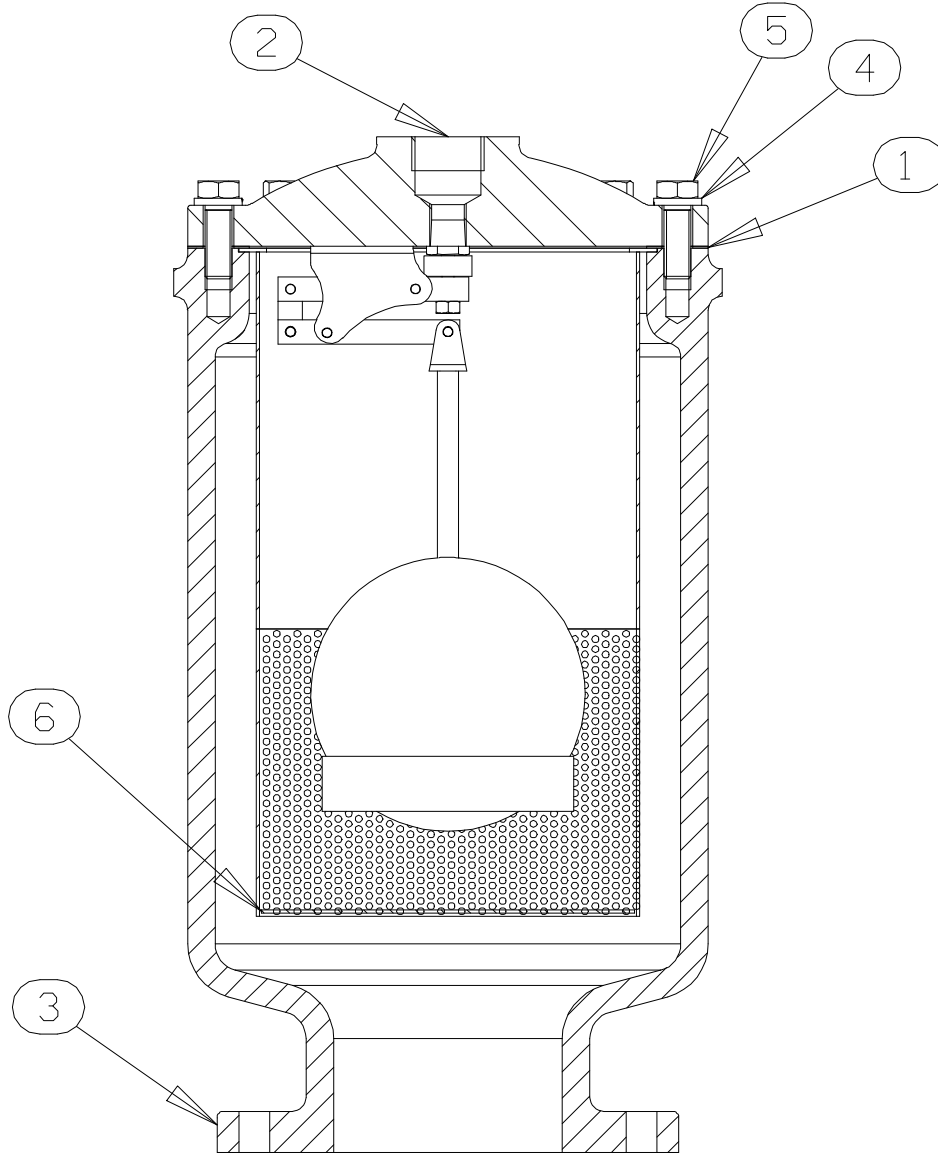

Figure 7. 46112-711 Priming Chamber Assembly

ITEM NO.	PART NAME	PART NUMBER	MAT'L CODE	QTY
1	* PRIMING VALVE GASKET	38683-657	19410	1
2	PRIMING VALVE	26664-008	---	1
	-ORIFICE BUTTON	26688-021	---	1
3	PRIMING CHAMBER	38343-020	17040	1
4	LOCKWASHER	J08	17090	8
5	HEX HD CAPSCREW	B0806	17090	8
6	STRAINER ASSY	46641-024	17040	1

* INDICATES PARTS RECOMMENDED FOR STOCK

PUMP AND SEAL DISASSEMBLY AND REASSEMBLY

Review all **SAFETY** information in Section A.

Follow the instructions on all tags, label and decals attached to the pump.

This pump requires little service due to its rugged, minimum-maintenance design. However, if it becomes necessary to inspect or replace the wearing parts, follow these instructions which are keyed to the sectional views (see Figures 1 through 7) and the accompanying parts lists.

This manual will alert personnel to known procedures which require special attention, to those which could damage equipment, and to those which could be dangerous to personnel. However, this manual cannot possibly anticipate and provide detailed precautions for every situation that might occur during maintenance of the unit. Therefore, it is the responsibility of the owner/maintenance personnel to ensure that **only** safe, established maintenance procedures are used, and that any procedures not addressed in this manual are performed **only** after establishing that neither personal safety nor pump integrity are compromised by such practices.

Before attempting to service the pump, switch off the engine ignition and disconnect the positive battery cable to ensure that the pump will remain inoperative. Close all valves in the suction and discharge lines.

For engine disassembly and repair, consult the literature supplied with the engine, or contact your local engine representative.



Before attempting to open or service the pump:

1. Familiarize yourself with this manual.
2. Shut down the engine and disconnect the positive battery cable to

ensure that the pump will remain inoperative.

3. Allow the pump to completely cool if overheated.
4. Check the temperature before opening any covers, plates, or plugs.
5. Close the suction and discharge valves.
6. Vent the pump slowly and cautiously.
7. Drain the pump.



This pump may be used to handle materials which could cause illness through direct exposure or emitted fumes. Wear adequate protective clothing when working on the pump or piping.



Use lifting and moving equipment in good repair and with adequate capacity to prevent injuries to personnel or damage to equipment. If slings or chains are used to move the pump or components, make sure that the load is balanced; otherwise serious personal injury or death could result. Suction and discharge hoses and piping must be removed from the pump before lifting.



This pump is equipped with automatic liquid level controls, and is subject to automatic restart. Keep hands and clothing away from the unit to prevent injury during automatic operation. Disconnect the positive battery cable before performing any maintenance. Failure to do so may result in serious personal injury.

Priming Chamber Removal And Disassembly

(Figure 6)

Disconnect the air discharge tubing from the priming chamber assembly (1). Support the priming chamber assembly using a sling and a suitable lifting device. Remove the hardware (9 and 10) and separate the priming chamber assembly, gasket (6) and baffle (7) from the suction spool (4, Figure 3).

(Figure 7)

Remove the hardware (4 and 5) securing the priming valve (1) to the priming chamber (3). Carefully lift the valve components from the priming chamber. Remove the gasket (1) and clean the mating surfaces.

If the priming valve float is stuck or the strainer (5) is clogged, it can usually be cleaned without further disassembly.

The only serviceable part of the priming valve is the orifice button (not shown). If liquid continues to bypass through the priming chamber after adjusting the orifice button (see **Priming Chamber Reassembly and Installation** for adjustment), the button may require replacement. To replace the orifice button, remove one of the “e-clips” from the pivot pin closest to the orifice button and remove the pivot pin. This will allow the linkage to be raised high enough to access the orifice button.

Remove the hex nut and lockwasher securing the orifice button to the linkage bar and unscrew the orifice button from the linkage bar.

Discharge Check Valve Removal and Disassembly

(Figure 3)

Remove the discharge piping. Support the discharge check valve assembly (6) using a sling and a suitable lifting device. Remove the attaching hardware (not shown) and separate the discharge check valve assembly and gasket from the pump assembly (1).

The flapper and cover gasket are the only serviceable parts of the check valve. If the flapper requires replacement, remove the hardware securing the

cover and gasket. Separate the valve cover and remove the flapper.

Suction Cover And Wear Ring Removal

(Figure 4)

It is not necessary to remove the suction spool (5, Figure 3) to remove the suction cover (54) unless the gasket (2, Figure 3) requires replacement. If removal is required, support the spool with a suitable hoist and sling and remove the hardware (3 and 4, Figure 3). Separate the spool from the suction cover and remove the gasket.

Remove the capscrews (49) securing the suction cover to the volute casing (1). If the spool is still attached to the suction cover, support the assembled spool and suction cover with a suitable hoist and sling. Carefully pry the suction cover out of the volute casing and remove the gasket (4).

Inspect the wear ring (51) for excessive wear or scoring. The wear ring is a press fit into the suction cover. If replacement is required, use a small bit to drill three holes horizontally, 120° apart, through the wear ring. Use a chisel or other suitable tool to complete the cuts through the wear ring. **Use caution** not to damage the suction cover bore. Remove the wear ring sections from the suction cover.

Pump Casing Removal

(Figure 4)

Before attempting to remove the pump casing, remove the lowermost pipe plug (5) and drain any liquid from the pump casing. Clean and reinstall the pipe plug.

If the impeller (2) is to be removed, it is recommended that the impeller lock screw (52) be loosened before removing the pump casing (1). With the discharge check valve removed, insert a soft metal bar or rod through the discharge port to block impeller rotation. If the discharge check valve has not been removed, disengage the hardware (47) and remove the cleanout cover and O-ring (45 and 46). Insert the metal bar or rod through the cleanout cover opening to immobilize the impeller.

The impeller lock screw is secured with “Loctite Threadlocker No. 262”. To remove the screw, apply

heat directly to the head of the screw. While the lock screw is hot, use an allen head socket and a breaker bar to apply steady, even torque to break the lock screw loose. Apply additional heat as required.

NOTE

*When loosening the impeller lock screw, use a breaker bar with an extension, if necessary, but **do not use an impact wrench**. Make sure the allen head tooling is in excellent condition to avoid stripping or damage to the screw.*

After the impeller lock screw breaks loose, remove the metal bar or rod blocking impeller rotation. If removed, reinstall the cleanout cover and gasket, and secure with the previously removed hardware before continuing with pump casing removal.

Support the pump casing (1) using a suitable hoist and sling. Disengage the capscrews (44). Reinstall two of the capscrews in the tapped holes in the back plate (6) and tighten the screws in an alternating pattern to jack the pump casing free from the back plate. **Use caution** to ensure that the pump casing does not fall onto and damage the impeller.

If no further disassembly is required, see **Pump Casing and Wear Ring Installation**.

Impeller Removal

(Figure 4)

Before attempting to remove the impeller, remove the pipe plug from the seal oil reservoir (40) and drain the seal lubricant into a clean container. Inspect the oil for water, dirt, or cloudy condition which could indicate seal failure.

With the reservoir drained, disconnect the hoses (37) from the back plate and drain any residual lubricant from the hoses and back plate. This will prevent the oil from escaping when the impeller is removed.

NOTE

When removing the impeller as described below, use extreme caution not to damage the impeller, shaft or bearings.

Remove the impeller lock nut and washer (52 and 53). Install two wedges, 180° apart, along the impeller vanes between the impeller and back plate. Use a pair of hammers to tap both wedges **at the same time** to force the impeller off the shaft. Retain the impeller key (50).

Seal Removal

(Figures 4 And 8)

Remove the seal spring. Remove the impeller shims (56). Tie and tag the shims for ease of reassembly.

Slide the rotating portion of the seal (consisting of the shaft sleeve (55) and O-ring (7), bellows and retainer, and rotating element) off the shaft as a unit.

Apply oil to the sleeve and work it up under the rubber bellows. Slide the bellows and retainer off the sleeve. Remove the sleeve O-ring.

It is recommended that the lip seal (8), spring (9) and V-ring (10) be replaced whenever the mechanical seal is replaced. Remove the hardware (42 and 43) and slide the back plate, lip seal and spring, and stationary seal seat off the shaft as a unit.

Press the seal stationary element out of the back plate from the back side. Pry the lip seal and spring out of the back plate.

Remove the V-ring.

If no further disassembly is required, refer to **Seal Installation**.

Separating Pump Frame And Drive Assembly From Engine

(Figure 5)

Further disassembly requires separating the pump frame and drive assembly from the engine. Support the pump frame (16, Figure 4) using a suitable hoist and sling.

Disengage the hardware (6 and 7) securing the engine bracket (22, Figure 4) to the engine bellhousing. Separate the pump frame and drive assembly from the engine by pulling the pump frame straight away from the engine.

As the assemblies separate, the flexible portion of the coupling assembly (2) will remain on the shaft.

To remove the coupling from the shaft, loosen the setscrew in the coupling hub and slide the coupling off the shaft. Remove the shaft key (5).

It is not necessary to remove the outer ring of the coupling from the engine flywheel unless the coupling must be replaced. To remove the ring, disengage the hardware (3 and 4) securing it to the flywheel.

Move the pump frame to a clean, well-equipped shop area for further disassembly.

Pump Shaft and Bearing Removal and Disassembly

(Figure 4)

When the pump is properly operated and maintained, the pump frame (16) should not require disassembly. Disassemble the shaft and bearings **only** when there is evidence of wear or damage.



Shaft and bearing disassembly in the field is not recommended. These operations should be performed only in a properly equipped shop by qualified personnel.

NOTE

The bearings in this pump are grease-lubricated. No provisions are made for draining the lubricant for disassembly. Position a drip pan under the frame before proceeding with shaft and bearing removal.

Disengage the capscrews (29) and remove the engine bracket (22) and oil seal (25). Remove the engine bracket shims (30 and 31). Press the oil seal from the engine bracket.

Disengage the capscrews (13) and remove the bracket (12) and oil seal (11). Press the oil seal from the bracket.

Place a block of wood against the impeller end of the shaft (23) and tap the shaft and assembled bearings (17 and 18) out of the pump frame. The bearing (14) will remain in the bearing frame.

After removing the shaft and bearings, clean and inspect the bearings **in place** as described in **Bearing Cleaning And Inspection**.

The bearing tolerances provide a tight press fit onto the shaft and a snug slip fit into the frame. Replace the bearings, shaft, or frame if the proper bearing fit is not achieved.

If bearing replacement is required, remove the bearing lockwasher and lock nut (20 and 21) and use a suitably sized sleeve and an arbor (or hydraulic) press to remove the bearings (17 and 18) from the shaft.

Use a suitably sized sleeve and an arbor (or hydraulic) press to press the bearing (14) from the frame.

Bearing Cleaning And Inspection

Clean the frame, shaft and all component parts (except the bearings) with a soft cloth soaked in cleaning solvent. Inspect the parts for wear or damage and replace as necessary.



Most cleaning solvents are toxic and flammable. Use them only in a well ventilated area free from excessive heat, sparks, and flame. Read and follow all precautions printed on solvent containers.

Clean the bearings thoroughly in **fresh** cleaning solvent. Dry the bearings with filtered compressed air and coat with light oil.



Bearings must be kept free of all dirt and foreign material. Failure to do so will greatly shorten bearing life. **Do not** spin dry bearings. This may scratch the balls or races and cause premature bearing failure.

Rotate the bearings by hand to check for roughness or binding and inspect the bearing balls. If rotation is rough, or the balls are discolored, replace the bearings.

Pump Shaft And Bearing Reassembly And Installation

(Figure 4)

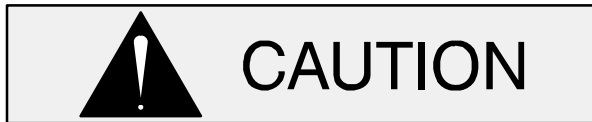

To prevent damage during removal from the shaft, it is recommended that bearings be cleaned and inspected **in place**. It is **strongly** recommended that the bearings be replaced **any** time the shaft and bearings are removed.

The bearings (17 and 18) may be heated to ease installation. **Do not** heat the bearing (14) before installation. An induction heater, hot oil bath, electric oven, or hot plate may be used to heat the bearings. Bearings should **never** be heated with a direct flame or directly on a hot plate.



Use caution when handling hot bearings to prevent burns.

NOTE

*If a hot oil bath is used to heat the bearings, both the oil and the container must be **absolutely** clean. If the oil has been previously used, it must be **thoroughly** filtered.*

Heat the bearings (17 and 18) to a uniform temperature **no higher than** 250°F (120°C). Slide the bearing (17) onto the shaft until fully seated against the shaft shoulder. This should be done quickly, in one continuous motion, to prevent the bearing from cooling and sticking on the shaft. After seating the inboard bearing (17) against the shaft shoulder, slide the outboard bearing (18) onto the shaft until fully seated against the inboard bearing.

After the bearings have been installed and allowed to cool, check to ensure that they have not moved in shrinking. If movement has occurred, use a suitably sized sleeve and a press to reposition the bearings.

If heating the bearings is not practical, use a suitably sized sleeve and an arbor (or hydraulic) press to install the bearings on the shaft.

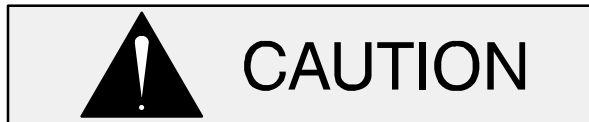

When installing the bearings onto the shaft, **never** press or hit against the outer race, balls, or ball cage. Press **only** on the inner race.

Press the bearing (14) into the bearing frame until fully seated against the bore shoulder. To ease installation, the bearing may be cooled in a refrigerator before installation.

After the bearings are installed on the shaft and in the bearing frame, and the bearings (17 and 18) have been allowed to cool, pack the bearings by hand with No. 2 extreme pressure grease. Fill the bearing cavity up to the bottom of the bearing bore with grease.

Secure the bearings (17 and 18) on the shaft with the bearing lock washer (20) and bearing lock nut (21). Fully tighten the lock nut, then back it off until the slot in the lock nut aligns with one of the tabs on the lock washer, then bend the tab on the lock-washer over to secure the lock nut.

Secure the bracket (12) to the frame (16) with the previously removed hardware (13).

Slide the shaft and assembled bearings into the frame until the shaft is fully seated against the inner race of the bearing (14).



When installing the shaft and bearings into the bearing bore, push against the outer race. **Never** hit the balls or ball cage.

Install the same thickness of shims (30 and 31) as previously removed, and secure the engine bracket to the frame with the previously removed hardware (29). Lubricate the shaft in the area of the oil seal (25) and use a suitably sized sleeve to press the oil seal into the engine bracket with the lip positioned as shown in Figure 4. Use caution not to cut or roll the lip of the oil seal during installation.

Lubricate the bearings as indicated in **LUBRICATION**.

Pump Frame and Drive Assembly Installation

(Figure 5)

Apply two drops of “Loctite Threadlocker No. 242” or equivalent compound to the shaft key (5) and install it in the shaft keyway. Position the flexible portion of the coupling assembly (2) on the shaft with the socket head capscrews positioned **toward the pump**. Align the keyway in the hub of the coupling assembly with the shaft key and slide the coupling onto the shaft to the dimension shown in Figure 5.



Make certain that the flexible portion of the coupling is mounted as shown in Figure 5. **This is critical.** If the coupling is not properly positioned on the shaft, the coupling parts may not fully engage, or a pre-load condition can cause premature bearing failure.

The end of the shaft must be recessed 0.50 inch (12,4 mm) from the face of the bushing. This will allow the two portions of the coupling to fully engage when the engine bracket is secured to the engine bellhousing without pre-loading the bearings.

With the flexible portion of the coupling properly positioned on the shaft, secure the coupling to the shaft by torquing the hub setscrew to 29 ft. lbs. (348 in. lbs. or 4 m. kg.).

If the complete coupling assembly is being replaced, apply ‘Loctite Retaining Compound No. 242’ or equivalent to the threads of the hardware (3 and 4) and secure the outer ring of the coupling to the engine flywheel by torquing the hardware to 45 ft. lbs. (540 in. lbs. or 6,2 m. kg.).

Using a suitable lifting device, position the pump frame so the flexible portion of the coupling seats inside the outer ring attached to the engine flywheel.

NOTE

To ease installation, **lightly** lubricate the rubber portion of the coupling with a **non-petroleum based lubricant** such as vegetable oil or glycerin, or a silicon-based lubricant such as “WD40” or equivalent. **Do not** use petroleum-based lubricants, or any other substance which may soften or otherwise damage the rubber.

Secure the engine bracket to the engine bellhousing with the hardware (6 and 7).

Seal Reassembly and Installation

(Figures 4 and 8)

Clean the bore of the back plate (6) and the shaft (23) with a cloth soaked in fresh cleaning solvent.



Most cleaning solvents are toxic and flammable. Use them only in a well ventilated area free from excessive heat, sparks, and flame. Read and follow all precautions printed on solvent containers.

Lay the back plate on a flat surface with the impeller side down. Install the spring (9) in the lip seal (8). Press the lip seal into the back plate with the lip positioned as shown in Figure 4.

The seal (3) is not normally reused because wear patterns on the finished faces cannot be realigned during reassembly. This could result in premature failure. If necessary to reuse an old seal in an emergency, **carefully** wash all metallic parts in fresh cleaning solvent and allow to dry thoroughly.

Handle the seal parts with extreme care to prevent damage. Be careful not to contaminate precision finished faces; even fingerprints on the faces can shorten seal life. If necessary, clean the faces with a non-oil based solvent and a clean, lint-free tissue. Wipe **lightly** in a concentric pattern to avoid scratching the faces.

Inspect the seal components for wear, scoring, grooves, and other damage that might cause leakage. Clean and polish the shaft sleeve, or replace it if there are nicks or cuts on either end. If any com-

ponents are worn, replace the complete seal; **never mix old and new seal parts.**

If a replacement seal is being used, remove it from the container and inspect the precision finished faces to ensure that they are free of any foreign

matter.

To ease installation of the seal, lubricate the bellows and stationary seat O-rings with water or a very **small** amount of oil, and apply a drop of light lubricating oil on the finished faces. Assemble the seal as follows (see Figure 8).

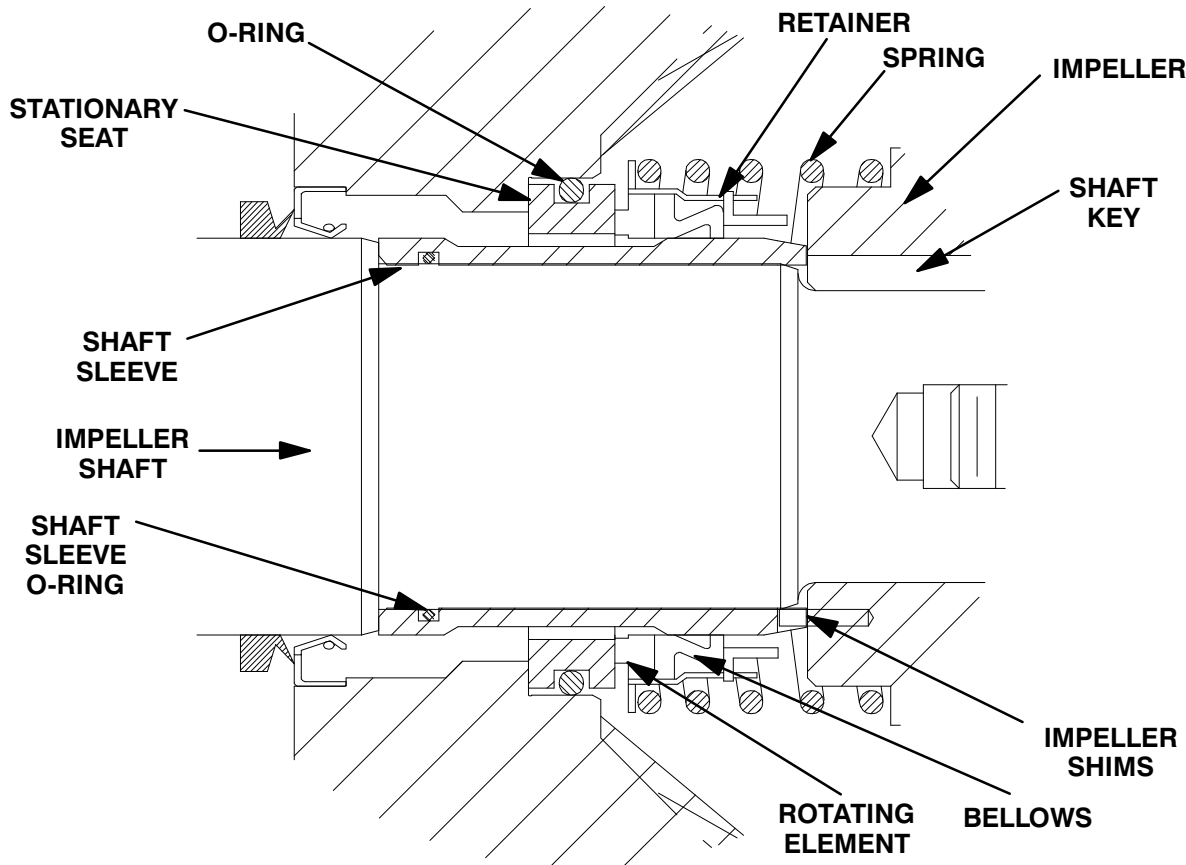
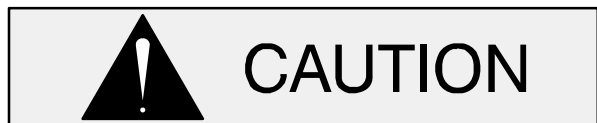

Figure 8. Seal Assembly



The seal is not designed for operation at temperatures above 160°F (71°C). Do not use at higher operating temperatures.

Install the O-ring (7) in the shaft sleeve (55) and lubricate it with light oil. Slide the V-ring (10) onto the sleeve with the lip toward the impeller end of the sleeve, then slide the sleeve onto the shaft until it is fully seated against the shaft shoulder.

Lubricate the stationary seat O-ring with water or light oil. Position the back plate with the impeller side up and press the stationary seat into the front

of the back plate until it seats squarely against the bore shoulder.

Carefully position the back plate and stationary seat over the shaft and secure it to the bracket (12) with the previously removed hardware (42 and 43). **Be careful** not to damage the stationary element on the shaft keyway. Make sure the lip on the V-ring seats against the lip seal (9).

Lubricate the O.D. of the seal sleeve with a **small** amount of light oil and slide the rotating sub-assembly (consisting of rotating element, bellows and retainer) onto the sleeve until the sealing faces contact.

Install the seal spring. Lubricate the seal as indicated in **LUBRICATION** after the impeller and remaining pump components are installed.

Impeller Installation

(Figures 4 and 9)

Inspect the impeller and replace it if cracked or badly worn.

Install the same thickness of impeller adjusting shims (56) as previously removed. Install the shaft key (46) and position the impeller on the shaft. See Figure 9, and use a section of pipe, washers and a long, 5/8–11 UNC capscrew to press the impeller onto the shaft until fully seated (**do not use the impeller lock screw**). Make sure the seal spring seats squarely over the step on the back side of the impeller.

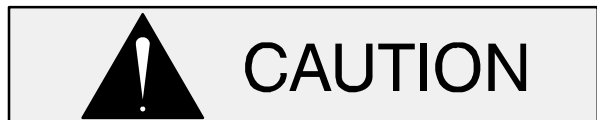

When installing the impeller, the capscrew must be long enough to enter the shaft at least eight full threads. Otherwise, damage to the shaft threads may occur.

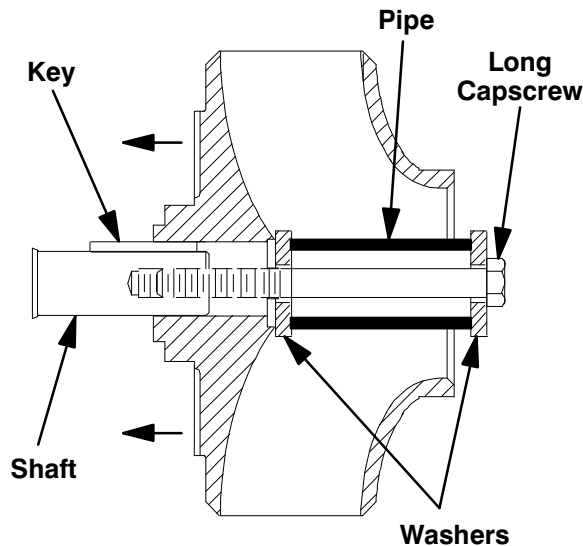

Figure 9. Installing Impeller

A clearance of approximately .030 inch (0,76 mm) between the impeller and the back plate is recommended for maximum pump efficiency. Measure this clearance, and add or remove impeller adjusting shims as required.

The pump casing must be installed in order to properly torque the impeller lock screw (52). After the impeller clearance has been set, install the pump casing as described below, then proceed as follows to install the impeller washer (53) and lock screw.

NOTE

To ensure proper torquing of the impeller lock screw, make sure the tapped hole in the impeller, the impeller washer and the impeller lock screw are clean and dry (it is not necessary to remove the protective coating from the capscrew). It is recommended that a new impeller lock screw be used whenever the impeller is removed. To ensure the proper lock screw material and specifications, use only genuine Gorman-Rupp replacement parts.

With the pump casing installed, coat the threads of a new impeller lock screw with “Loctite Threadlocker No. 262” or equivalent compound, and install the impeller washer and lock screw. Immobilize the impeller by inserting a soft metal bar or rod through the discharge opening or cleanout cover opening as described in **Pump Casing And Wear Ring Removal**. With the impeller immobilized, torque the impeller lock screw to the specifications shown in Table E-1.

Table E-1. Impeller Lock Screw Torque Values

Screw Size (UNC)	Torque Ft. Lbs. (M. Kg.)
.38-16	20 (2,8)
.50-13	40 (5,5)
.62-11	90 (12,4)
.75-10	135 (18,7)
1.00-8	265 (36,6)
1.12-7	360 (49,8)
1.25-7	510 (70,5)
1.50-6	875 (121,0)

Remove the metal bar or rod from the discharge opening or cleanout cover opening.

Pump Casing Installation

(Figure 4)

Install the casing gasket (48). Use a suitable hoist and sling to position the pump casing (1) over the impeller, and secure it to the back plate with the capscrews (44).

Suction Cover and Wear Ring Installation

(Figure 4)

If the wear ring (51) was removed from the suction cover (54), chill the replacement wear ring by refrigeration and press it into the suction cover bore until fully seated.



The wear ring **must** seat squarely in the suction cover; otherwise binding and/or excessive wear will occur.

Install the suction cover gasket (4). Use a suitable hoist and sling to position the suction cover in the pump casing opening. Use the capscrews (49) to draw the suction cover into the pump casing until fully seated.

Check the clearance between the impeller and the wear ring for scraping or binding and correct any before putting the pump back into service.

Discharge Check Valve Assembly And Installation

(Figure 3)

The flapper and cover O-ring are the only serviceable parts of the check valve. If the flapper requires replacement, remove the hardware securing the cover and O-ring. Separate the valve cover and replace the flapper.

Install the valve cover O-ring and secure the cover with the previously removed hardware.

Support the discharge check valve assembly (6) using a sling and a suitable lifting device. Use the previously removed hardware to secure the dis-

charge check valve assembly and gasket to the pump assembly (1).

Priming Chamber Assembly And Installation

(Figure 7)

Clean and inspect the components of the priming valve (2). Inspect the linkage and ensure the orifice button (not shown) squarely engages the valve seat. Replace the orifice button if required (see **Priming Chamber Removal and Disassembly** for orifice button removal).

If the orifice button was removed, screw the new orifice button into the linkage bar until fully seated. Align the hole in the linkage bar with the holes in the bracket and reinstall the pivot pin. Secure the pivot pin with the previously removed “e-clip”.

Adjust the orifice button seating as necessary by screwing the orifice button into or out of the linkage bar. Proper adjustment is achieved when the orifice button fully seats against the orifice before the linkage bar on the float bottoms against the threads on the orifice button. When adjustment is complete, install and tighten the lock washer and hex nut securing the orifice button.

Install the strainer (6) and priming valve gasket (1).

Lower the float into the priming chamber (3) and secure the priming valve with the previously removed hardware (4 and 5).

(Figure 6)

Install the baffle (7) and gasket (6) and use a sling and suitable lifting device to position the priming chamber assembly on the hopper spool (not shown). Secure the priming chamber assembly with the hardware (9 and 10).

Reconnect the suction piping to the hopper spool and the air discharge tubing to the priming chamber assembly.

LUBRICATION

Seal Assembly

(Figure 4)

Check the oil level regularly at the sight gauge on the seal oil reservoir and maintain it at the top of the

gauge. When lubrication is required, remove the breather on top of the reservoir and add **synthetic oil** of an ISO viscosity grade 22 or lower.

Under normal conditions, drain the seal cavity and reservoir every 1000 hours or once each year, whichever comes first, and refill with clean oil. Change the oil more frequently if the pump is operated continuously or installed in an environment with rapid temperature change.

When adding oil after draining, or if the oil in the reservoir has dropped below the sight gauge, air must be purged out of the upper circulation hose to prevent vapor locking. To accomplish this, disconnect the upper hose from the oil reservoir and hold the hose below its point of entry in the seal cavity. Fill the reservoir until the oil begins to run from the hose, then reconnect the hose to the oil reservoir.

Bearings

(Figure 4)

The bearings were fully lubricated when shipped from the factory. Lubricate the bearings after every

1,500 hours of service. To lubricate the bearings, remove the plastic covers from the grease fittings (19 and 33) and be sure the fitting and the end of the grease gun are clean.

Use **only** a hand-operated grease gun and pump approximately 6 pumps of No. 2 extreme pressure grease through each grease fitting. **Do not** over-lubricate. Excess grease will be forced through the bearings and into the bearing cavity. If too much grease is retained in the bearing cavity, the bearings can over-heat, resulting in premature bearing failure.

When lubricating a re-built bearing frame, remove the breather vent (32) and fill the bearing cavity with a good grade of No. 0 lithium base grease to the bottom of the shaft (23). Reinstall the breather vent.

Engine

Consult the literature supplied with the engine, or contact your local engine representative.

**For U.S. and International Warranty Information,
Please Visit www.grpumps.com/warranty**

or call:

U.S.: 419-755-1280

International: +1-419-755-1352

**For Canadian Warranty Information,
Please Visit www.grcanada.com/warranty**

or call:

519-631-2870