**INSTALLATION, OPERATION,
AND MAINTENANCE MANUAL**
WITH PARTS LIST



SUPER T SERIES® PUMPS

MODELS
T8A65S-B INCLUDING: /F, /FM

GORMAN-RUPP PUMPS

www.grpumps.com

Register your new
Gorman-Rupp pump online at
www.grpumps.com

Valid serial number and e-mail address required.

RECORD YOUR PUMP MODEL AND SERIAL NUMBER

Please record your pump model and serial number in the spaces provided below. Your Gorman-Rupp distributor needs this information when you require parts or service.

Pump Model: _____

Serial Number: _____

TABLE OF CONTENTS

INTRODUCTION	PAGE I – 1
SAFETY – SECTION A	PAGE A – 1
INSTALLATION – SECTION B	PAGE B – 1
Pump Dimensions	PAGE B – 1
PREINSTALLATION INSPECTION	PAGE B – 2
POSITIONING PUMP	PAGE B – 2
Lifting	PAGE B – 2
Mounting	PAGE B – 2
Clearance	PAGE B – 2
SUCTION AND DISCHARGE PIPING	PAGE B – 3
Materials	PAGE B – 3
Line Configuration	PAGE B – 3
Connections to Pump	PAGE B – 3
Gauges	PAGE B – 3
SUCTION LINES	PAGE B – 3
Fittings	PAGE B – 3
Strainers	PAGE B – 3
Sealing	PAGE B – 3
Suction Lines In Sumps	PAGE B – 4
Suction Line Positioning	PAGE B – 4
DISCHARGE LINES	PAGE B – 5
Siphoning	PAGE B – 5
Valves	PAGE B – 5
Bypass Lines	PAGE B – 5
AUTOMATIC AIR RELEASE VALVE	PAGE B – 6
Air Release Valve Installation	PAGE B – 6
ALIGNMENT	PAGE B – 7
Coupled Drives	PAGE B – 8
Drive Belts	PAGE B – 8
DRIVE BELT TENSIONING	PAGE B – 9
General Rules of Tensioning	PAGE B – 9
OPERATION – SECTION C	PAGE C – 1
PRIMING	PAGE C – 1
STARTING	PAGE C – 1
Rotation	PAGE C – 1
OPERATION	PAGE C – 2
Lines With a Bypass	PAGE C – 2
Lines Without a Bypass	PAGE C – 2
OPERATIONAL CHECKS	PAGE C – 2
Leakage	PAGE C – 2
Liquid Temperature and Overheating	PAGE C – 2
Strainer Check	PAGE C – 3
Clog Removal and Wear Plate Clearance	PAGE C – 3
Pump Vacuum Check	PAGE C – 3
STOPPING	PAGE C – 3
Cold Weather Preservation	PAGE C – 4

TABLE OF CONTENTS
(continued)

BEARING TEMPERATURE CHECK	PAGE C – 4
TROUBLESHOOTING – SECTION D	PAGE D – 1
PREVENTIVE MAINTENANCE	PAGE D – 3
PUMP MAINTENANCE AND REPAIR – SECTION E	PAGE E – 1
PERFORMANCE CURVE	PAGE E – 1
PARTS LISTS:	
Pump Model	PAGE E – 3
Repair Rotating Assembly	PAGE E – 5
PUMP AND SEAL DISASSEMBLY AND REASSEMBLY	PAGE E – 6
Back Cover and Wear Plate Removal	PAGE E – 7
Suction Check Valve Removal	PAGE E – 7
Rotating Assembly Removal	PAGE E – 7
Impeller Removal	PAGE E – 9
Seal Removal	PAGE E – 9
Shaft and Bearing Removal and Disassembly	PAGE E – 9
Shaft and Bearing Reassembly and Installation	PAGE E – 10
Seal Installation	PAGE E – 12
Impeller Installation and Adjustment	PAGE E – 13
Rotating Assembly Installation	PAGE E – 14
Suction Check Valve Installation	PAGE E – 14
Back Cover Installation and Adjustment	PAGE E – 14
PRESSURE RELIEF VALVE MAINTENANCE	PAGE E – 15
Final Pump Assembly	PAGE E – 16
LUBRICATION	PAGE E – 16
Seal Assembly	PAGE E – 16
Bearings	PAGE E – 16

INTRODUCTION

Thank You for purchasing a Gorman-Rupp pump. **Read this manual** carefully to learn how to safely install and operate your pump. Failure to do so could result in personal injury or damage to the pump.

Because pump installations are seldom identical, this manual cannot possibly provide detailed instructions and precautions for every aspect of each specific application. Therefore, it is the responsibility of the owner/installer of the pump to ensure that applications not addressed in this manual are performed **only** after establishing that neither operator safety nor pump integrity are compromised by the installation. Pumps and related equipment **must** be installed and operated according to all national, local and industry standards.

If there are any questions regarding the pump or its application which are not covered in this manual or in other literature accompanying this unit, please contact your Gorman-Rupp distributor, or The Gorman-Rupp Company:

The Gorman-Rupp Company
P.O. Box 1217
Mansfield, Ohio 44901—1217
Phone: (419) 755—1011
 or:
Gorman-Rupp of Canada Limited
70 Burwell Road
St. Thomas, Ontario N5P 3R7
Phone: (519) 631—2870

For information or technical assistance on the power source, contact the power source manufacturer's local dealer or representative.

HAZARD AND INSTRUCTION DEFINITIONS

The following are used to alert maintenance personnel to procedures which require special attention, to those which could damage equipment, and to those which could be dangerous to personnel:



Immediate hazards which WILL result in severe personal injury or death. These instructions describe the procedure required and the injury which will result from failure to follow the procedure.



Hazards or unsafe practices which COULD result in severe personal injury or death. These instructions describe the procedure required and the injury which could result from failure to follow the procedure.



Hazards or unsafe practices which COULD result in minor personal injury or product or property damage. These instructions describe the requirements and the possible damage which could result from failure to follow the procedure.

NOTE

Instructions to aid in installation, operation, and maintenance or which clarify a procedure.

SAFETY – SECTION A

This information applies to Super T Series® basic pumps. Gorman-Rupp has no control over or particular knowledge of the power source which will be used. Refer to the manual accompanying the power source before attempting to begin operation.

This manual will alert personnel to known procedures which require special attention, to those which could damage equipment, and to those which could be dangerous to personnel. However, this manual cannot possibly provide detailed instructions and precautions for each specific application or for every situation that might occur during maintenance of the unit. Therefore, it is the responsibility of the owner, installer and/or maintenance personnel to ensure that applications and/or maintenance procedures not addressed in this manual are performed only after establishing that neither personal safety nor pump integrity are compromised by such applications or procedures.



Before attempting to open or service the pump:

1. Familiarize yourself with this manual.
2. Disconnect or lock out the power source to ensure that the pump will remain inoperative.
3. Allow the pump to completely cool if overheated.
4. Check the temperature before opening any covers, plates, or plugs.
5. Close the suction and discharge valves.
6. Vent the pump slowly and cautiously.
7. Drain the pump.



This pump is designed to handle liquids containing large entrained solids or slurries. Do not attempt to pump volatile, corrosive, or flammable materials which may damage the pump or endanger personnel as a result of pump failure.



Death or serious personal injury and damage to the pump or components can occur if proper lifting procedures are not observed. Make certain that hoists, chains, slings or cables are in good working condition and of sufficient capacity and that they are positioned so that loads will be balanced and the pump or components will not be damaged when lifting. Suction and discharge hoses and piping must be removed from the pump before lifting. Lift the pump or component only as high as necessary and keep personnel away from suspended objects.



After the pump has been positioned, make certain that the pump and all piping connections are tight, properly supported and secure before operation.



Do not remove plates, covers, gauges, pipe plugs, or fittings from an overheated pump. Vapor pressure within the pump can cause parts being disengaged to be ejected with great force. Allow the pump to cool before servicing.

**WARNING!**

Do not operate the pump against a closed discharge valve for long periods of time. If operated against a closed discharge valve, pump components will deteriorate, and the liquid could come to a boil, build pressure, and cause the pump casing to rupture or explode.

**WARNING!**

Overheated pumps can cause severe burns and injuries. If overheating of the pump occurs:

1. Stop the pump immediately.
2. Ventilate the area.
3. Allow the pump to completely cool.
4. Check the temperature before opening any covers, plates, gauges, or plugs.
5. Vent the pump slowly and cautiously.
6. Refer to instructions in this manual before restarting the pump.

**WARNING!**

Do not operate the pump without the guards in place over the rotating parts. Exposed rotating parts can catch clothing, fingers, or tools, causing severe injury to personnel.

**WARNING!**

Never run this pump backwards. Be certain that rotation is correct before fully engaging the pump.

**CAUTION**

Pumps and related equipment must be installed and operated according to all national, local and industry standards.

INSTALLATION – SECTION B

Review all SAFETY information in Section A.

Since pump installations are seldom identical, this section offers only general recommendations and practices required to inspect, position, and arrange the pump and piping.

Most of the information pertains to a standard **static lift application** where the pump is positioned above the free level of liquid to be pumped.

If installed in a **flooded suction application** where the liquid is supplied to the pump under pressure, some of the information such as mounting, line configuration, and priming must be tailored to the

specific application. Since the pressure supplied to the pump is critical to performance and safety, **be sure** to limit the incoming pressure to **50%** of the maximum permissible operating pressure as shown on the pump performance curve.

For further assistance, contact your Gorman-Rupp distributor or the Gorman-Rupp Company.

Pump Dimensions

See Figure 1 for the approximate physical dimensions of this pump.

OUTLINE DRAWING

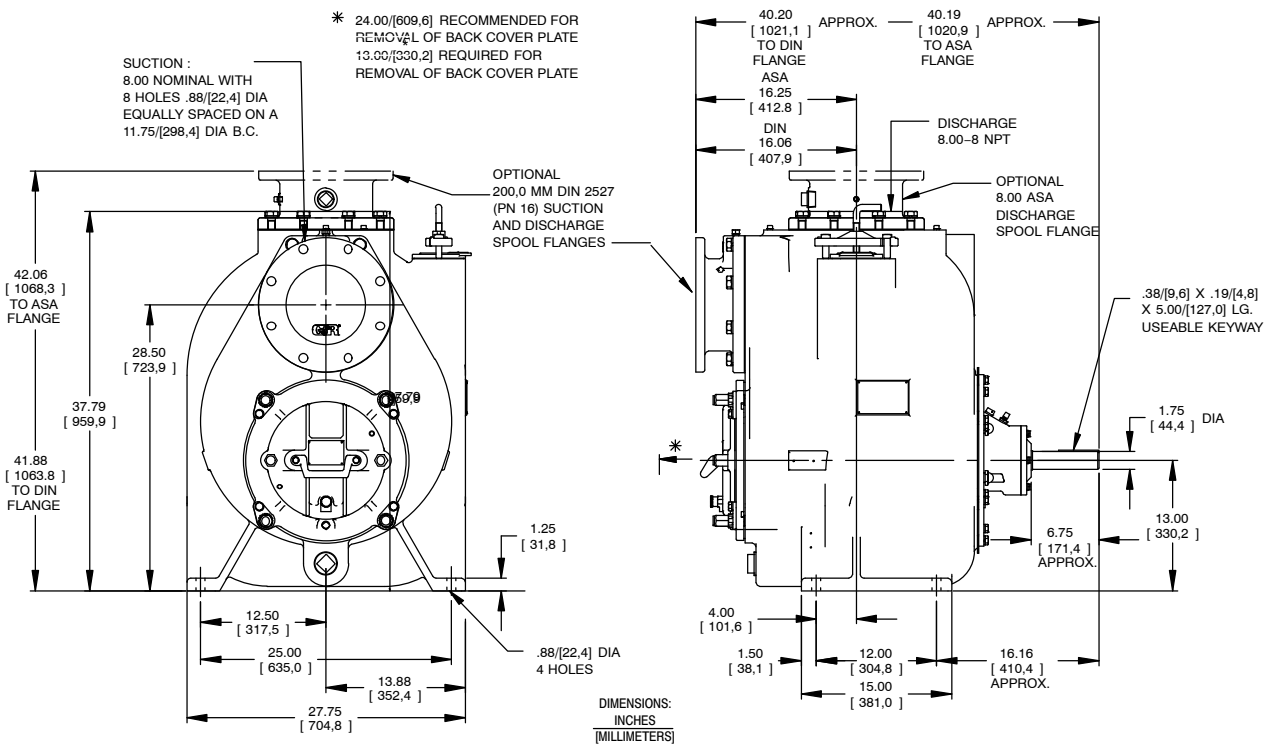

NOTE: OPTIONAL ASA OR DIN STANDARD SUCTION & DISCHARGE SPOOL FLANGES AVAILABLE

Figure 1. Pump Model T8A65S-B, Including /F, /FM

PREINSTALLATION INSPECTION

The pump assembly was inspected and tested before shipment from the factory. Before installation, inspect the pump for damage which may have occurred during shipment. Check as follows:

- a. Inspect the pump for cracks, dents, damaged threads, and other obvious damage.
- b. Check for and tighten loose attaching hardware. Since gaskets tend to shrink after drying, check for loose hardware at mating surfaces.
- c. Carefully read all warnings and cautions contained in this manual or affixed to the pump, and perform all duties indicated. Note the direction of rotation indicated on the pump. Check that the pump shaft rotates counter-clockwise when facing the impeller.



Only operate this pump in the direction indicated by the arrow on the pump body and on the accompanying decal. Refer to **ROTATION** in **OPERATION**, Section C.

- d. Check levels and lubricate as necessary. Refer to **LUBRICATION** in the **MAINTENANCE AND REPAIR** section of this manual and perform duties as instructed.
- e. If the pump and power source have been stored for more than 12 months, some of the components or lubricants may have exceeded their maximum shelf life. These **must be inspected or replaced** to ensure maximum pump service.

If the maximum shelf life has been exceeded, or if anything appears to be abnormal, contact your Gorman-Rupp distributor or the factory to determine the repair or updating policy. **Do not** put the pump into service until appropriate action has been taken.

POSITIONING PUMP



Death or serious personal injury and damage to the pump or components can occur if proper lifting procedures are not observed. Make certain that hoists, chains, slings or cables are in good working condition and of sufficient capacity and that they are positioned so that loads will be balanced and the pump or components will not be damaged when lifting. Suction and discharge hoses and piping must be removed from the pump before lifting. Lift the pump or component only as high as necessary and keep personnel away from suspended objects.

Lifting

Pump unit weights will vary depending on the mounting and drive provided. Check the shipping tag on the unit packaging for the actual weight, and use lifting equipment with appropriate capacity. Drain the pump and remove all customer-installed equipment such as suction and discharge hoses or piping before attempting to lift existing, installed units.

Mounting

Locate the pump in an accessible place as close as practical to the liquid being pumped. Level mounting is essential for proper operation.

The pump may have to be supported or shimmed to provide for level operation or to eliminate vibration.

Clearance

It is recommended that **24 inches (609,6 mm)** of clearance be provided in front of the back cover to permit removal of the cover and easy access to the pump interior. A **minimum** clearance of **13 inches (330,2 mm)** must be maintained to permit removal of the cover.

SUCTION AND DISCHARGE PIPING

Pump performance is adversely effected by increased suction lift, discharge elevation, and friction losses. See the performance curve and operating range shown on Page E-1 to be sure your overall application allows pump to operate within the safe operation range.

Materials

Either pipe or hose maybe used for suction and discharge lines; however, the materials must be compatible with the liquid being pumped. If hose is used in suction lines, it must be the rigid-wall, reinforced type to prevent collapse under suction. Using piping couplings in suction lines is not recommended.

Line Configuration

Keep suction and discharge lines as straight as possible to minimize friction losses. Make minimum use of elbows and fittings, which substantially increase friction loss. If elbows are necessary, use the long-radius type to minimize friction loss.

Connections to Pump

Before tightening a connecting flange, align it exactly with the pump port. Never pull a pipe line into place by tightening the flange bolts and/or couplings.

Lines near the pump must be independently supported to avoid strain on the pump which could cause excessive vibration, decreased bearing life, and increased shaft and seal wear. If hose-type lines are used, they should have adequate support to secure them when filled with liquid and under pressure.

Gauges

Most pumps are drilled and tapped for installing discharge pressure and vacuum suction gauges. If these gauges are desired for pumps that are not tapped, drill and tap the suction and discharge lines not less than 18 inches (457,2 mm) from the

suction and discharge ports and install the lines. Installation closer to the pump may result in erratic readings.

SUCTION LINES

To avoid air pockets which could affect pump priming, the suction line must be as short and direct as possible. When operation involves a suction lift, the line must always slope upward to the pump from the source of the liquid being pumped; if the line slopes down to the pump at any point along the suction run, air pockets will be created.

Fittings

Suction lines should be the same size as the pump inlet. If reducers are used in suction lines, they should be the eccentric type, and should be installed with the flat part of the reducers uppermost to avoid creating air pockets. Valves are not normally used in suction lines, but if a valve is used, install it with the stem horizontal to avoid air pockets.

Strainers

If a strainer is furnished with the pump, be certain to use it; any spherical solids which pass through a strainer furnished with the pump will also pass through the pump itself.

If a strainer is not furnished with the pump, but is installed by the pump user, make certain that the total area of the openings in the strainer is at least three or four times the cross section of the suction line, and that the openings will not permit passage of solids larger than the solids handling capability of the pump.

This pump is designed to handle up to 3-inch (76,2 mm) diameter spherical solids.

Sealing

Since even a slight leak will affect priming, head, and capacity, especially when operating with a high suction lift, all connections in the suction line should be sealed with pipe dope to ensure an air-tight seal. Follow the sealant manufacturer's recommendations when selecting and applying the pipe dope. The pipe dope should be compatible with the liquid being pumped.

Suction Lines In Sumps

If a single suction line is installed in a sump, it should be positioned away from the wall of the sump at a distance equal to 1 1/2 times the diameter of the suction line.

If there is a liquid flow from an open pipe into the sump, the flow should be kept away from the suction inlet because the inflow will carry air down into the sump, and air entering the suction line will reduce pump efficiency.

If it is necessary to position inflow close to the suction inlet, install a baffle between the inflow and the suction inlet at a distance 1 1/2 times the diameter of the suction pipe. The baffle will allow entrained air to escape from the liquid before it is drawn into the suction inlet.

If two suction lines are installed in a single sump, the flow paths may interact, reducing the efficiency

of one or both pumps. To avoid this, position the suction inlets so that they are separated by a distance equal to at least 3 times the diameter of the suction pipe.

Suction Line Positioning

The depth of submergence of the suction line is critical to efficient pump operation. Figure 2 shows recommended minimum submergence vs. velocity.

NOTE

The pipe submergence required may be reduced by installing a standard pipe increaser fitting at the end of the suction line. The larger opening size will reduce the inlet velocity. Calculate the required submergence using the following formula based on the increased opening size (area or diameter).

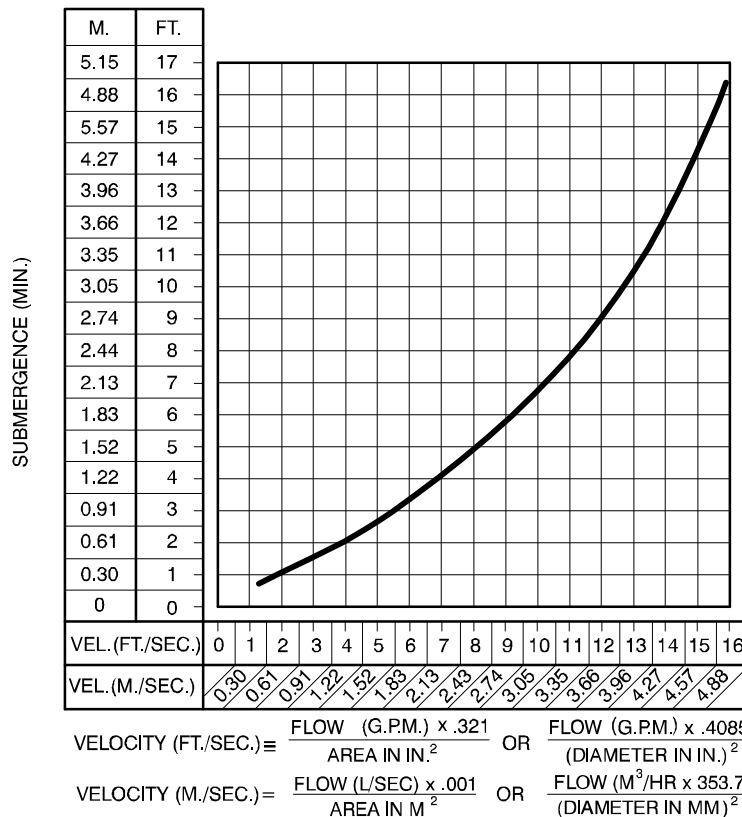

Figure 2. Recommended Minimum Suction Line Submergence vs. Velocity

DISCHARGE LINES

Siphoning

Do not terminate the discharge line at a level lower than that of the liquid being pumped unless a siphon breaker is used in the line. Otherwise, a siphoning action causing damage to the pump could result.

Valves

If a throttling valve is desired in the discharge line, use a valve as large as the largest pipe to minimize friction losses. Never install a throttling valve in a suction line.

With high discharge heads, it is recommended that a throttling valve and a system check valve be installed in the discharge line to protect the pump from excessive shock pressure and reverse rotation when it is stopped.

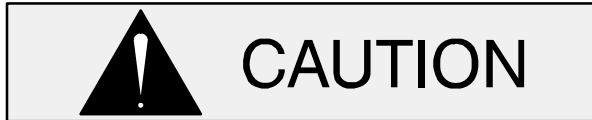

If the application involves a high discharge head, gradually close the discharge throttling valve before stopping the pump.

Bypass Lines

Self-priming pumps are not air compressors. During the priming cycle, air from the suction line must be vented to atmosphere on the discharge side. If the discharge line is open, this air will be vented through the discharge. However, if a check valve has been installed in the discharge line, the discharge side of the pump must be opened to atmospheric pressure through a bypass line installed between the pump discharge and the check valve. A self-priming centrifugal pump **will not prime** if there is sufficient static liquid head to hold the discharge check valve closed.

NOTE

The bypass line should be sized so that it does not affect pump discharge capacity; however, the bypass line should be at least 1 inch in diameter to

minimize the chance of plugging.

In **low discharge head applications** (less than 30 feet or 9 meters), it is recommended that the bypass line be run back to the wet well, and located 6 inches below the water level or cut-off point of the low level pump. In some installations, this bypass line may be terminated with a six-to-eight foot length of 1 1/4 inch I.D. **smooth-bore** hose; air and liquid vented during the priming process will then agitate the hose and break up any solids, grease, or other substances likely to cause clogging.

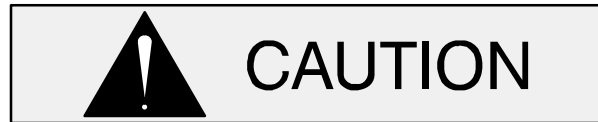

A bypass line that is returned to a wet well must be secured against being drawn into the pump suction inlet.

It is also recommended that pipe unions be installed at each 90° elbow in a bypass line to ease disassembly and maintenance.

In **high discharge head applications** (more than 30 feet), an excessive amount of liquid may be bypassed and forced back to the wet well under the full working pressure of the pump; this will reduce overall pumping efficiency. **Therefore, it is recommended that a Gorman-Rupp Automatic Air Release Valve be installed in the bypass line.**

Gorman-Rupp Automatic Air Release Valves are reliable, and require minimum maintenance. See **AUTOMATIC AIR RELEASE VALVE** in this section for installation and theory of operation of the Automatic Air Release Valve. Consult your Gorman-Rupp distributor, or contact the Gorman-Rupp Company for selection of an Automatic Air Release Valve to fit your application.

If the installation involves a flooded suction such as a below-ground lift station. A pipe union and manual shut-off valve may be installed in the bleed line to allow service of the valve without shutting down the station, and to eliminate the possibility of flooding. If a manual shut-off valve is installed **anywhere** in the air release piping, it **must** be a full-opening **ball type** valve to prevent plugging by solids.



If a manual shut-off valve is installed in a bypass line, it must not be left closed during operation. A closed manual shut-off valve may cause a pump which has lost prime to continue to operate without reaching prime, causing dangerous overheating and possible explosive rupture of the pump casing. Personnel could be severely injured.

Allow an over-heated pump to completely cool before servicing. Do not remove plates, covers, gauges, or fittings from an over-heated pump. Liquid within the pump can reach boiling temperatures, and vapor pressure within the pump can cause parts being disengaged to be ejected with great force. After the pump completely cools, drain the liquid from the pump by removing the casing drain plug. Use caution when removing the plug to prevent injury to personnel from hot liquid.

AUTOMATIC AIR RELEASE VALVE

When properly installed, a Gorman-Rupp Automatic Air Release Valve will permit air to escape through the bypass line and then close automatically when the pump is fully primed and pumping at full capacity.



Some leakage (1 to 5 gallons [3.8 to 19 liters] per minute) will occur when the valve is fully closed. Be sure the bypass line is directed back to the wet well or tank to prevent hazardous spills.

Consult the manual accompanying the Air Release Valve for additional information on valve installation and performance.

Air Release Valve Installation

The Automatic Air Release Valve must be independently mounted in a horizontal position between the pump discharge port and the inlet side of the discharge check valve (see Figure 3). The inlet opening in the Air Release Valve is equipped with standard 1-inch NPT pipe threads.

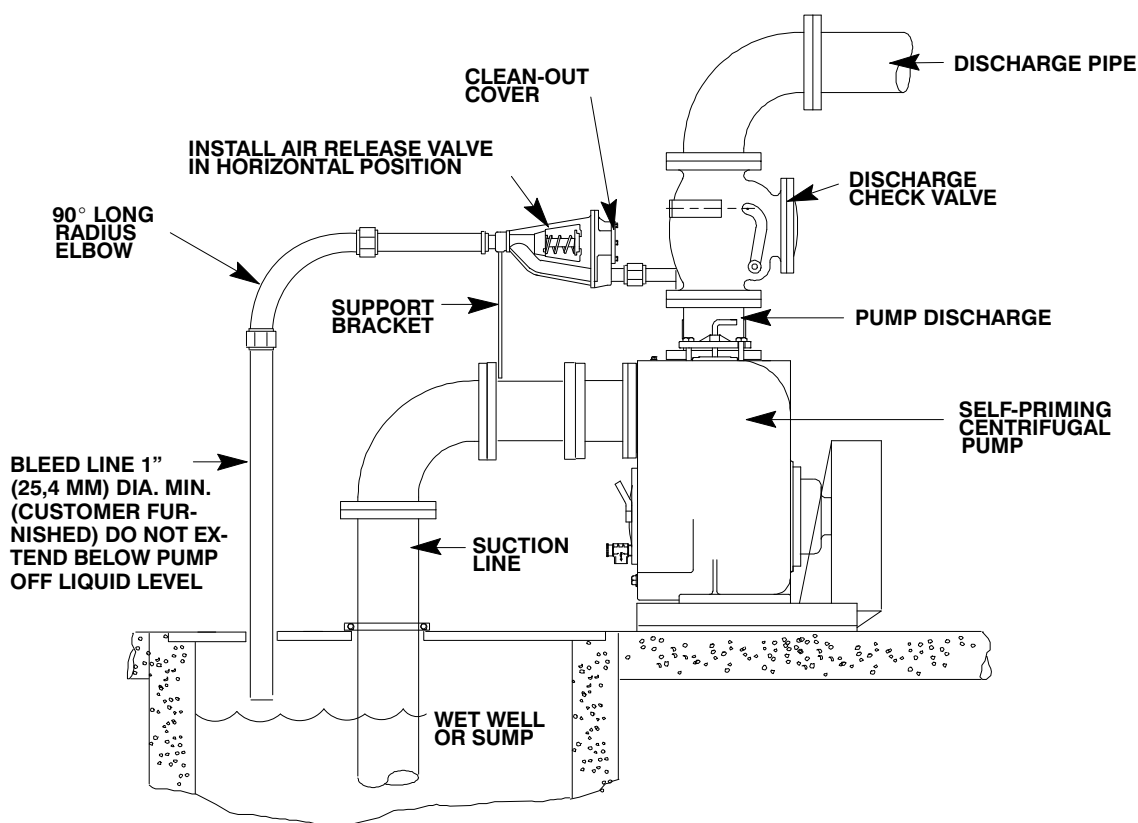

Figure 3. Typical Automatic Air Release Valve Installation

Connect the valve outlet to a bleed line which slopes back to the wet well or sump. The bleed line must be the same size as the outlet opening or larger, depending on which Air Release Valve is being used. If **pipng** is used for the bleed line, avoid the use of elbows whenever possible.

NOTE

*For multiple pump installations, it is recommended that each Air Release Valve be fitted with an independent bleeder line directed back to the wet well. If multiple Air Release Valves are installed in a system, **do not** direct bleeder lines to a common manifold pipe. Contact your Gorman-Rupp distributor or the Gorman-Rupp Company for information about installation of an Automatic Air Release Valve for your specific application.*

shafts are aligned with and parallel to each other. It is imperative that alignment be checked after the pump and piping are installed, and before operation.

NOTE

*Check **Rotation**, Section C, before final alignment of the pump.*

When mounted at the Gorman-Rupp factory, driver and pump are aligned before shipment. Misalignment will occur in transit and handling. Pumps **must** be checked and realigned before operation. Before checking alignment, tighten the foundation bolts. The pump casing feet and/or pedestal feet, and the driver mounting bolts should also be tightly secured.

ALIGNMENT

The alignment of the pump and its power source is critical for trouble-free mechanical operation. In either a flexible coupling or V-belt driven system, the driver and pump must be mounted so that their



When checking alignment, disconnect the power source to ensure that the pump will remain inoperative.



Adjusting the alignment in one direction may alter the alignment in another direction. Check each procedure after altering alignment.

Coupled Drives

When using couplings, the axis of the power source must be aligned to the axis of the pump shaft in both the horizontal and vertical planes. Most couplings require a specific gap or clearance between the driving and the driven shafts. Refer to the coupling manufacturer's service literature.

Align spider insert type couplings by using calipers to measure the dimensions on the circumference of the outer ends of the coupling hub every 90°. The coupling is in alignment when the hub ends are the same distance apart at all points (see Figure 4).



Figure 4. Aligning Spider-Type Couplings

Align non-spider type couplings by using a feeler gauge or taper gauge between the coupling halves every 90°. The coupling is in alignment when the hubs are the same distance apart at all points (see Figure 5).



Figure 5. Aligning Non-Spider Type Couplings

Check parallel adjustment by laying a straightedge across both coupling rims at the top, bottom, and side. When the straightedge rests evenly on both halves of the coupling, the coupling is in horizontal parallel alignment. If the coupling is misaligned, use a feeler gauge between the coupling and the straightedge to measure the amount of misalignment.

Drive Belts

When using drive belts, the power source and the pump must be parallel. Use a straightedge along the sides of the pulleys to ensure that the pulleys are properly aligned (see Figure 6). In drive systems using two or more belts, make certain that the belts are a matched set; unmatched sets will cause accelerated belt wear.



MISALIGNED: SHAFTS NOT PARALLEL MISALIGNED: SHAFTS NOT IN LINE ALIGNED: SHAFTS PARALLEL AND SHEAVES IN LINE

Figure 6. Alignment of V-Belt Driven Pumps

Tighten the belts in accordance with the belt manufacturer's instructions. If the belts are too loose, they will slip; if the belts are too tight, there will be excessive power loss and possible bearing failure.

Select pulleys that will match the proper speed ratio; overspeeding the pump may damage both pump and power source.



Do not operate the pump without the guard in place over the rotating parts. exposed rotating parts can catch clothing, fingers, or tools, causing severe injury to personnel.

DRIVE BELT TENSIONING

General Rules of Tensioning

For new drive belts, check the tension after 5, 20 and 50 hours of operation and re-tension as required (see the following procedure for measuring belt tension). Thereafter, check and re-tension if required monthly or at 500 hour intervals, whichever comes first.

Ideal drive belt tension is the **lowest** tension at which the belt will not slip under peak load conditions. Do not over-tension drive belts. Over-tensioning will shorten both drive belt and bearing life. Under-tensioning will cause belt slippage. Always keep belts free from dirt, grease, oil and other foreign material which may cause slippage.

OPERATION – SECTION C

Review all **SAFETY** information in Section A.

Follow the instructions on all tags, labels and decals attached to the pump.



This pump is designed to handle liquids containing large entrained solids and slurries. Do not attempt to pump volatile, corrosive, or flammable liquids which may damage the pump or endanger personnel as a result of pump failure.



Pump speed and operating conditions must be within the performance range shown on page E-1.

PRIMING

Install the pump and piping as described in **INSTALLATION**. Make sure that the piping connections are tight, and that the pump is securely mounted. Check that the pump is properly lubricated (see **LUBRICATION** in **MAINTENANCE AND REPAIR**).

This pump is self-priming, but the pump should never be operated unless there is liquid in the pump casing.



Never operate this pump unless there is liquid in the pump casing. The pump will not prime when dry. extended operation of a dry pump will destroy the seal assembly.

Add liquid to the pump casing when:

1. The pump is being put into service for the first time.

2. The pump has not been used for a considerable length of time.
3. The liquid in the pump casing has evaporated.

Once the pump casing has been filled, the pump will prime and reprime as necessary.



After filling the pump casing, reinstall and tighten the fill plug. Do not attempt to operate the pump unless all connecting piping is securely installed. Otherwise, liquid in the pump forced out under pressure could cause injury to personnel.

To fill the pump, remove the pump casing fill cover or fill plug in the top of the casing, and add clean liquid until the casing is filled. Replace the fill cover or fill plug before operating the pump.

STARTING

Consult the operations manual furnished with the power source.

Rotation

The correct direction of pump rotation is counterclockwise when facing the impeller. The pump could be damaged and performance adversely affected by incorrect rotation. If pump performance is not within the specified limits (see the curve on page E-1), check the direction of power source rotation before further troubleshooting.



Only operate this pump in the direction indicated by the arrow on the pump body and on the accompanying decal. Otherwise, the impeller could become loosened from the shaft and seriously damage the pump.

Consult the operating manual furnished with the power source before attempting to start the power source.

If an electric motor is used to drive the pump, remove V-belts, couplings, or otherwise disconnect the pump from the motor before checking motor rotation. Operate the motor independently while observing the direction of the motor shaft, or cooling fan.

If rotation is incorrect on a three-phase motor, have a qualified electrician interchange any two of the three phase wires to change direction. If rotation is incorrect on a single-phase motor, consult the literature supplied with the motor for specific instructions.

OPERATION

Lines With a Bypass

If a Gorman-Rupp Automatic Air Release Valve has been installed, the valve will automatically open to allow the pump to prime, and automatically close after priming is complete (see **INSTALLATION** for Air Release Valve operation).

If the bypass line is open, air from the suction line will be discharged through the bypass line back to the wet well during the priming cycle. Liquid will then continue to circulate through the bypass line while the pump is in operation.

Lines Without a Bypass

Open all valves in the discharge line and start the power source. Priming is indicated by a positive reading on the discharge pressure gauge or by a quieter operation. The pump may not prime immediately because the suction line must first fill with liquid. If the pump fails to prime within five minutes, stop it and check the suction line for leaks.

After the pump has been primed, partially close the discharge line throttling valve in order to fill the line slowly and guard against excessive shock pressure which could damage pipe ends, gaskets, sprinkler heads, and any other fixtures connected to the line. When the discharge line is completely

filled, adjust the throttling valve to the required flow rate.



Do not operate the pump against a closed discharge throttling valve for long periods of time. If operated against a closed discharge throttling valve, pump components will deteriorate, and the liquid could come to a boil, build pressure, and cause the pump casing to rupture or explode.

OPERATIONAL CHECKS

Leakage

No leakage should be visible at pump mating surfaces, or at pump connections or fittings. Keep all line connections and fittings tight to maintain maximum pump efficiency.

Liquid Temperature and Overheating

The **maximum** liquid temperature for this pump is 160°F (71°C). Do not apply it at a higher operating temperature.

Overheating can occur if operated with the valves in the suction or discharge lines closed. Operating against closed valves could bring the liquid to a boil, build pressure, and cause the pump to rupture or explode. If overheating occurs, stop the pump and allow it to cool before servicing it. Refill the pump casing with cool liquid.



Allow an over-heated pump to completely cool before servicing. Do not remove plates, covers, gauges, or fittings from an over-heated pump. Liquid within the pump can reach boiling temperatures, and vapor pressure within the pump can cause parts being disen-

gaged to be ejected with great force. **After the pump completely cools, drain the liquid from the pump by removing the casing drain plug. Use caution when removing the plug to prevent injury to personnel from hot liquid.**

As a safeguard against rupture or explosion due to heat, this pump is equipped with a pressure relief valve which will open if vapor pressure within the pump casing reaches a critical point. If overheating does occur, stop the pump immediately and allow it to cool before servicing it. **Approach any overheated pump cautiously.** It is recommended that the pressure relief valve assembly be replaced at each overhaul, or any time the pump casing overheats and activates the valve. **Never** replace this valve with a substitute which has not been specified or provided by the Gorman-Rupp Company.

Strainer Check

If a suction strainer has been shipped with the pump or installed by the user, check the strainer regularly, and clean it as necessary. The strainer should also be checked if pump flow rate begins to drop. If a vacuum suction gauge has been installed, monitor and record the readings regularly to detect strainer blockage.

Never introduce air or steam pressure into the pump casing or piping to remove a blockage. This could result in personal injury or damage to the equipment. If backflushing is absolutely necessary, liquid pressure **must** be limited to 50% of the maximum permissible operating pressure shown on the pump performance curve.

Clog Removal and Wear Plate Clearance



Before attempting to open or service the pump:

1. **Familiarize yourself with this manual.**

2. **Disconnect or lock out the power source to ensure that the pump will remain inoperative.**
3. **Allow the pump to completely cool if overheated.**
4. **Check the temperature before opening any covers, plates, or plugs.**
5. **Close the suction and discharge valves.**
6. **Vent the pump slowly and cautiously.**
7. **Drain the pump.**

This pump is equipped with an inspection cover to provide easy access to the interior of the pump for removal of debris and to check the impeller-to-wear plate clearance. Remove the inspection cover and check for clogging any time pump performance appears to be below the desired application levels. Check the wear plate clearance monthly and adjust the clearance if necessary as described in **Back Cover Installation and Adjustment** in Section E, **Maintenance and Repair**. The recommended impeller-to-wear plate clearance is .010 to .020 inch (0,25 to 0,50 mm).

Pump Vacuum Check

With the pump inoperative, install a vacuum gauge in the system, using pipe dope on the threads. Block the suction line and start the pump. At operating speed the pump should pull a vacuum of 20 inches (508,0 mm) or more of mercury. If it does not, check for air leaks in the seal, gasket, or discharge valve.

Open the suction line, and read the vacuum gauge with the pump primed and at operation speed. Shut off the pump. The vacuum gauge reading will immediately drop proportionate to static suction lift, and should then stabilize. If the vacuum reading falls off rapidly after stabilization, an air leak exists. Before checking for the source of the leak, check the point of installation of the vacuum gauge.

STOPPING

Never halt the flow of liquid suddenly. If the liquid being pumped is stopped abruptly, damaging

shock waves can be transmitted to the pump and piping system. Close all connecting valves slowly.

On engine driven pumps, reduce the throttle speed slowly and allow the engine to idle briefly before stopping.



If the application involves a high discharge head, gradually close the discharge throttling valve before stopping the pump.

After stopping the pump, lock out or disconnect the power source to ensure that the pump will remain inoperative.



Do not operate the pump against a closed discharge throttling valve for long periods of time. If operated against a closed discharge throttling valve, pump components will deteriorate, and the liquid could come to a boil, build pressure, and cause the pump casing to rupture or explode.

Cold Weather Preservation

In below freezing conditions, drain the pump to prevent damage from freezing. Also, clean out any solids by flushing with a hose. Operate the pump for approximately one minute; this will remove any

remaining liquid that could freeze the pump rotating parts. If the pump will be idle for more than a few hours, or if it has been pumping liquids containing a large amount of solids, drain the pump, and flush it thoroughly with clean water. To prevent large solids from clogging the drain port and preventing the pump from completely draining, insert a rod or stiff wire in the drain port, and agitate the liquid during the draining process. Clean out any remaining solids by flushing with a hose.

BEARING TEMPERATURE CHECK

Bearings normally run at higher than ambient temperatures because of heat generated by friction. Temperatures up to 160°F (71°C) are considered normal for bearings, and they can operate safely to at least 180°F (82°C).

Checking bearing temperatures by hand is inaccurate. Bearing temperatures can be measured accurately by placing a contact-type thermometer against the housing. Record this temperature for future reference.

A sudden increase in bearing temperature is a warning that the bearings are at the point of failing to operate properly. Make certain that the bearing lubricant is of the proper viscosity and at the correct level (see **LUBRICATION** in **MAINTENANCE AND REPAIR**). Bearing overheating can also be caused by shaft misalignment and/or excessive vibration.

When pumps are first started, the bearings may seem to run at temperatures above normal. Continued operation should bring the temperatures down to normal levels.

TROUBLESHOOTING – SECTION D

Review all SAFETY information in Section A.



Before attempting to open or service the pump:

1. Familiarize yourself with this manual.
2. Lock out or disconnect the power source to ensure that the pump will remain inoperative.
3. Allow the pump to completely cool if overheated.
4. Check the temperature before opening any covers, plates, or plugs.
5. Close the suction and discharge valves.
6. Vent the pump slowly and cautiously.
7. Drain the pump.

TROUBLE	POSSIBLE CAUSE	PROBABLE REMEDY
<p>PUMP FAILS TO PRIME</p>	<p>Not enough liquid in casing.</p> <p>Suction check valve contaminated or damaged.</p> <p>Air leak in suction line.</p> <p>Lining of suction hose collapsed.</p> <p>Leaking or worn seal or pump gasket.</p> <p>Suction check valve or foot valve clogged or binding.</p> <p>Suction lift or discharge head too high.</p> <p>Strainer clogged.</p> <p>Plugged or malfunctioning air release line or air release valve (if so equipped).</p>	<p>Add liquid to casing. See PRIMING.</p> <p>Clean or replace check valve.</p> <p>Correct leak.</p> <p>Replace suction hose.</p> <p>Check pump vacuum. Replace leaking or worn seal or gasket.</p> <p>Clean valve.</p> <p>Check piping installation and install bypass line if needed. See INSTALLATION.</p> <p>Check strainer and clean if necessary.</p> <p>Check, clean and/or repair air release valve and piping.</p>
<p>PUMP STOPS OR FAILS TO DELIVER RATED FLOW OR PRESSURE</p>	<p>Air leak in suction line.</p> <p>Lining of suction hose collapsed.</p> <p>Leaking or worn seal or pump gasket.</p>	<p>Correct leak.</p> <p>Replace suction hose.</p> <p>Check pump vacuum. Replace leaking or worn seal or gasket.</p>

TROUBLE	POSSIBLE CAUSE	PROBABLE REMEDY
PUMP STOPS OR FAILS TO DELIVER RATED FLOW OR PRESSURE (cont.)	<p>Suction intake not submerged at proper level or sump too small.</p> <p>Impeller or other wearing parts worn or damaged.</p> <p>Strainer clogged.</p> <p>Impeller clogged.</p> <p>Suction lift or discharge head too high.</p> <p>Pump speed too slow.</p>	<p>Check installation and correct submergence as needed.</p> <p>Replace worn or damaged parts. Check that impeller is properly centered and rotates freely.</p> <p>Check strainer and clean if necessary.</p> <p>Free impeller of debris.</p> <p>Check piping installation and install bypass line if needed. See INSTALLATION.</p> <p>Check driver output; check belts or couplings for slippage.</p>
PUMP REQUIRES TOO MUCH POWER	<p>Pump speed too high.</p> <p>Discharge head too low.</p> <p>Liquid solution too thick.</p>	<p>Check driver output; check that sheaves or couplings are correctly sized.</p> <p>Adjust discharge valve.</p> <p>Dilute if possible.</p>
PUMP CLOGS FREQUENTLY	<p>Discharge flow too slow.</p> <p>Suction check valve or foot valve clogged or binding.</p>	<p>Open discharge valve fully to increase flow rate, and run engine at maximum governed speed.</p> <p>Clean valve.</p>
EXCESSIVE NOISE	<p>Cavitation in pump.</p> <p>Pumping entrained air.</p> <p>Pump or drive not securely mounted.</p> <p>Impeller clogged or damaged.</p> <p>Suction and discharge lines not properly supported.</p>	<p>Reduce suction lift and/or friction losses in suction line. Record vacuum and pressure gauge readings and consult local representative or factory.</p> <p>Locate and eliminate source of air bubble.</p> <p>Secure mounting hardware.</p> <p>Clean out debris; replace damaged parts.</p> <p>Check piping installation for proper support.</p>
BEARINGS RUN TOO HOT	<p>Bearing temperature is high, but within limits.</p> <p>Low or incorrect lubricant.</p> <p>Drive misaligned.</p> <p>Pump speed too high.</p> <p>Bearing(s) frozen.</p>	<p>Check bearing temperature regularly to monitor any increase.</p> <p>Check for proper type and level of lubricant.</p> <p>Align drive properly.</p> <p>Reduce speed of power source.</p> <p>Disassemble pump and check bearing(s).</p>

PREVENTIVE MAINTENANCE

Since pump applications are seldom identical, and pump wear is directly affected by such things as the abrasive qualities, pressure and temperature of the liquid being pumped, this section is intended only to provide general recommendations and practices for preventive maintenance. Regardless of the application however, following a routine preventive maintenance schedule will help assure trouble-free performance and long life from your Gorman-Rupp pump. For specific questions concerning your application, contact your Gorman-Rupp distributor or the Gorman-Rupp Company.

Record keeping is an essential component of a good preventive maintenance program. Changes in suction and discharge gauge readings (if so

equipped) between regularly scheduled inspections can indicate problems that can be corrected before system damage or catastrophic failure occurs. The appearance of wearing parts should also be documented at each inspection for comparison as well. Also, if records indicate that a certain part (such as the seal) fails at approximately the same duty cycle, the part can be checked and replaced before failure occurs, reducing unscheduled down time.

For new applications, a first inspection of wearing parts at 250 hours will give insight into the wear rate for your particular application. Subsequent inspections should be performed at the intervals shown on the chart below. Critical applications should be inspected more frequently.

Preventive Maintenance Schedule					
Item	Service Interval*				
	Daily	Weekly	Monthly	Semi-Annually	Annually
General Condition (Temperature, Unusual Noises or Vibrations, Cracks, Leaks, Loose Hardware, Etc.)	I				
Pump Performance (Gauges, Speed, Flow)	I				
Bearing Lubrication		I			R
Seal Lubrication (And Packing Adjustment, If So Equipped)		I			R
V-Belts (If So Equipped)			I		
Air Release Valve Plunger Rod (If So Equipped)			I	C	
Front Impeller Clearance (Wear Plate)				I	
Rear Impeller Clearance (Seal Plate)				I	
Check Valve					I
Pressure Relief Valve (If So Equipped)					C
Pump and Driver Alignment					I
Shaft Deflection					I
Bearings					I
Bearing Housing					I
Piping					I
Driver Lubrication – See Mfgr’s Literature					I

Legend:
 I = Inspect, Clean, Adjust, Repair or Replace as Necessary
 C = Clean
 R = Replace

* Service interval based on an intermittent duty cycle equal to approximately 4000 hours annually. Adjust schedule as required for lower or higher duty cycles or extreme operating conditions.

PUMP MAINTENANCE AND REPAIR – SECTION E

MAINTENANCE AND REPAIR OF THE WEARING PARTS OF THE PUMP WILL MAINTAIN PEAK OPERATING PERFORMANCE.

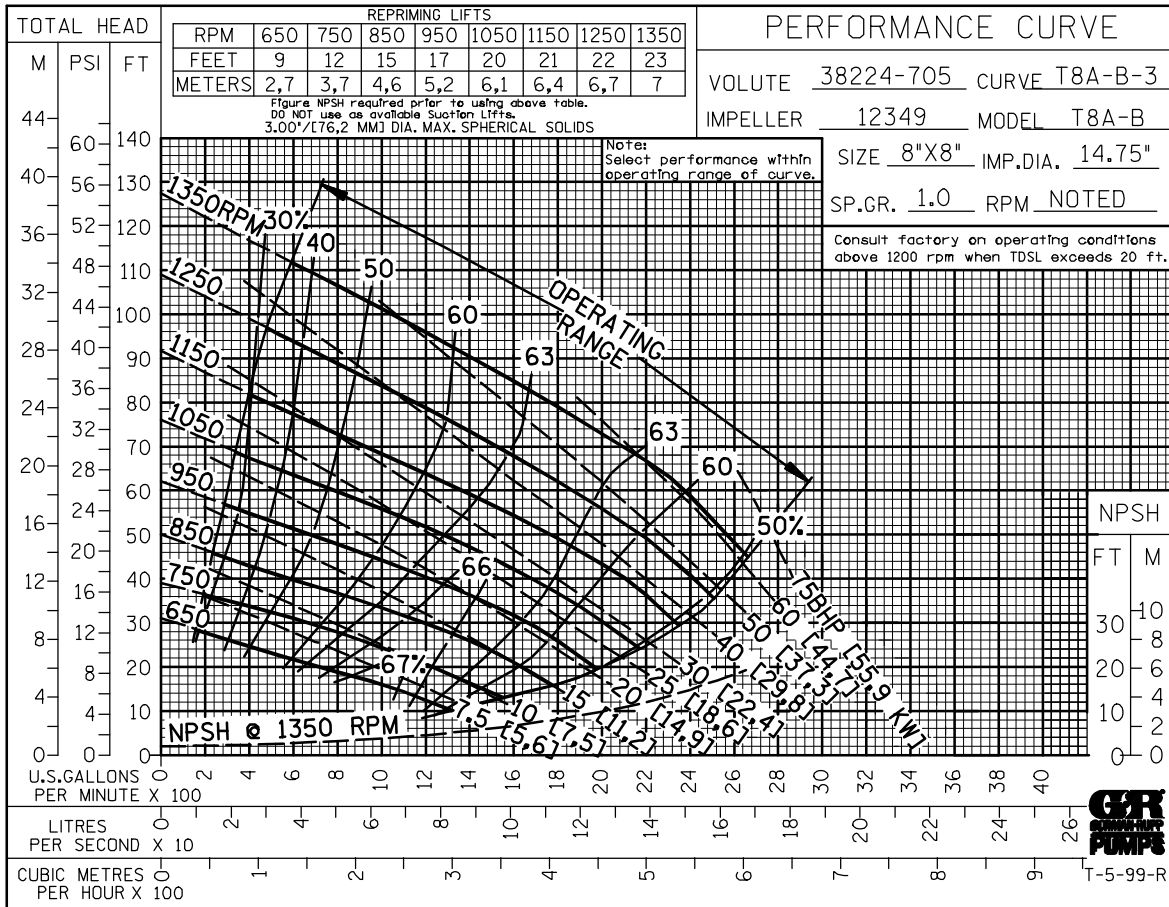

*** STANDARD PERFORMANCE FOR PUMP MODEL T8A65S-B, Including /F, /FM**

* Based on 70°F (21°C) clear water at sea level with minimum suction lift. Since pump installations are seldom identical, your performance may be different due to such factors as viscosity, specific gravity, elevation, temperature, and impeller trim.

Contact the Gorman-Rupp Company to verify performance or part numbers.



If your pump serial number is followed by an "N", your pump is **NOT** a standard production model.

Pump speed and operating condition points must be within the continuous performance range shown on the curve.

ILLUSTRATION

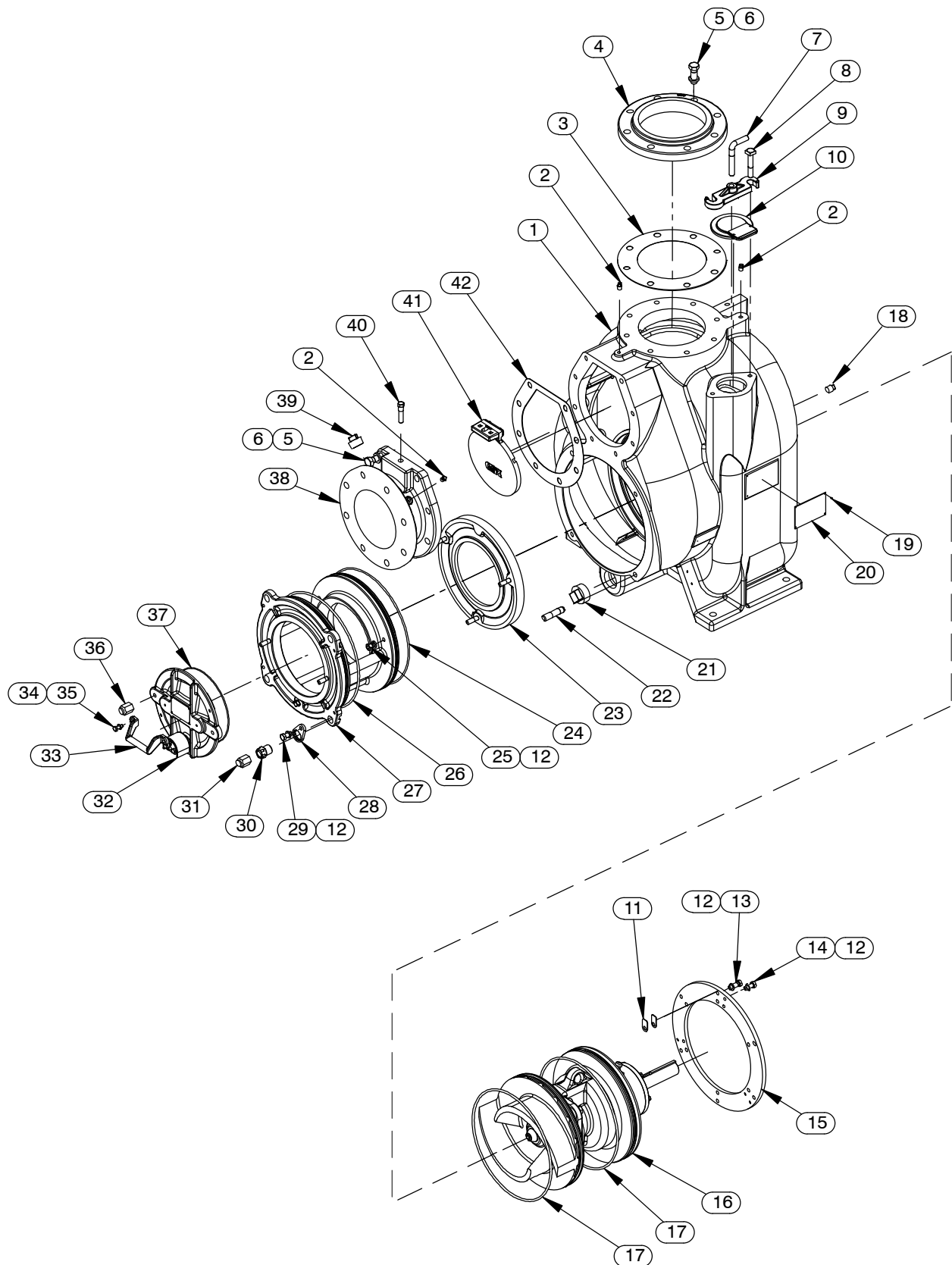

Figure 1. Pump Model T8A65S-B, including /F, /FM

PARTS LIST
Pump Model T8A65S-B, including /F, /FM
 (From S/N 1727309 Up)

If your pump serial number is followed by an "N", your pump is **NOT** a standard production model. Contact the Gorman-Rupp Company to verify part numbers.

ITEM NO.	PART NAME	PART NUMBER	QTY	ITEM NO.	PART NAME	PART NUMBER	QTY
1	PUMP CASING	SEE NOTE BELOW	1	34	LOCK WASHER	J06 17090	2
2	PIPE PLUG	P04 17090	3	35	HEX HEAD CAP SCREW	B0604 17090	2
3 *	GASKET	1759GB 19410	1	36	BACK COVER NUT	31871-075 17040	2
4	DISCHARGE FLANGE:			37 *	O-RING	25154-273	1
	-T8A65S-B	1759 17070	1	38	SUCTION FLANGE:		
	-T8A65S-B /F	12799 17180	1		-T8A65S-B, /F	12356 17180	1
	-T8A65S-B /FM	38642-612 17180	1		-T8A65S-B /FM	38642-611 17180	1
5	HEX HEAD CAP SCREW	B1209 17090	16	39	PIPE PLUG	P20 17090	1
6	LOCK WASHER	J12 17090	16	40	CHECK VALVE PIN	12357 17090	1
7	SCREW-CLAMP BAR	31912-009 1704G	1	41 *	8" FLAP VALVE ASSY	46411-084	1
8	MACHINE BOLT	A1014 17090	2	42 *	GASKET	12356G 19410	1
9	CLAMP BAR	38111-004 17040	1		NOT SHOWN:		
10	FILL CVR PLATE ASSY	42111-385	1		DISCHARGE STICKER	6588BJ	1
	-WARNING PLATE	38816-097 17090	1		LUBRICATION DECAL	38817-084	1
	-DRIVE SCREW	BM#04-03 17090	2		WARNING DECAL	2613FE	1
	* -COVER GASKET	50G 19210	1		G-R DECAL 6 IN	GR-06	1
11	ADJ SHIM	33221-018 17040	12		INSTRUCTION TAG	38817-023	1
12	LOCK WASHER	J08 17090	19		SUPER "T" DECAL	38812-089	1
13	HEX HEAD CAP SCREW	B0806 17090	6		INSTRUCTION TAG	38817-011	1
14	HEX HEAD CAP SCREW	B0805 17090	6		ROTATION DECAL	2613M	1
15	VOLUTE RING	31281-016 17040	1		SUCTION STICKER	6588AG	1
16	REPAIR ROTATING ASSY	44163-372	1		FILL TO PRIME STICKER	6588AH	1
17 *	O-RING	25154-458	2		OPTIONAL:		
18	PIPE PLUG	P08 17090	1		DISASSEMBLY TOOL	12858 24000	1
19	DRIVE SCREW	BM#04-03 17090	4		CASING HEATERS:		
20	NAMEPLATE BLANK	38819-002 17040	1		-120V	47811-001	1
21	PIPE PLUG	P32 17090	1		-240V	47811-002	1
22	STUD	C1213 1706G	4		/F DISCHARGE FLANGE	12799 17180	1
23 *	WEAR PLATE ASSEMBLY	46451-789	1		/FM METRIC FLANGES:		
24 *	O-RING	25154-384	1		-SUCTION	38642-611 17180	1
25	HEX NUT	D08 17090	3		-DISCHARGE	38642-612 17180	1
26 *	O-RING	25154-459	1		CHECK VALVE ASSYS:		
27	BACK COVER ASSEMBLY	42111-846	1		-NEO SOLID TYPE	46411-018	1
28	LOCK COLLAR	38115-551 17040	4	✓	-VITON SOLID	46411-080	1
29	HEX HEAD CAP SCREW	B0804-1/2 17090	4	✓	-VITON BLOW-OUT	46411-090	1
30	ADJUSTING SCREW	31871-070 1704G	4		AIR RELEASE VALVES:		
31	BACK COVER NUT	31871-073 17040	4		-10# COMP SPRING	GRP33-07D	1
32	INSPECT COVER ASSY	42111-460	1		-25# COMP SPRING	GRP33-07C	1
	-WARNING PLATE	2613EV 17090	1		-80# COMP SPRING	GRP33-07E	1
	-DRIVE SCREW	BM#04-03 17090	4		** SELF CLEANING		
	* -PRESS RELIEF VALVE	46431-803	1		WEAR PLATE	38691-874 1718H	1
33	HANDLE	12354 17040	1				

* INDICATES PARTS RECOMMENDED FOR STOCK

☞ INCLUDED WITH REPAIR 46472-717 1
 PUMP CASING ASSY

✓ VITON® IS A REGISTERED TRADEMARK OF THE DUPONT CORP.

COMPLETE GASKET/O-RING AND SHAFT REPAIR KITS AVAILABLE – CONSULT FACTORY.

** FOR PUMP RETRO-FITTING, BACK COVER OPENING MUST BE 9.00 INCH DIAMETER - CONSULT FACTORY FOR DETAILS.

ILLUSTRATION

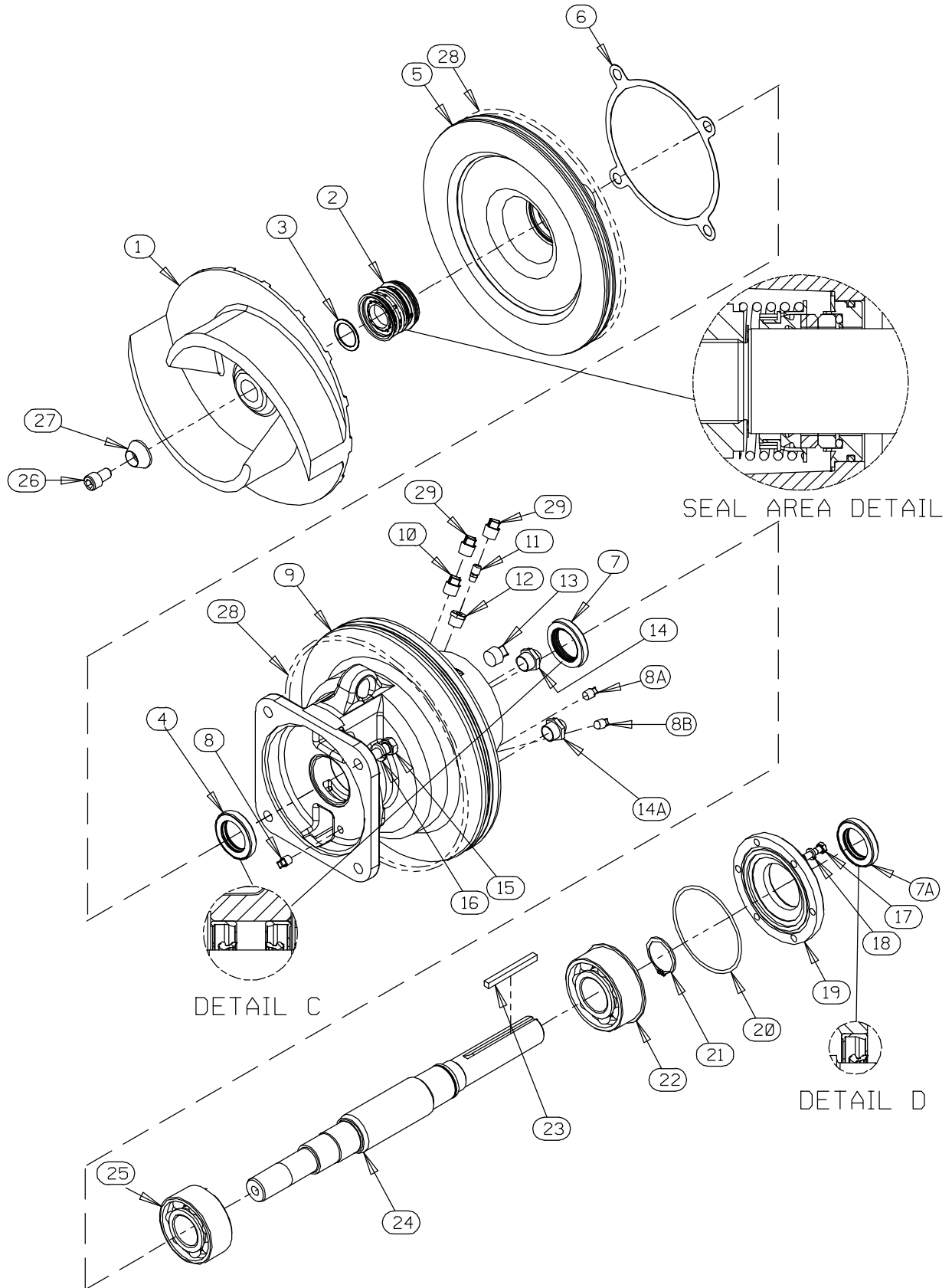

Figure 2. Repair Rotating Assembly

PARTS LIST

Repair Rotating Assembly

ITEM NO.	PART NAME	PART NUMBER	QTY	ITEM NO.	PART NAME	PART NUMBER	QTY
1 *	IMPELLER	12349 1718H	1	17	HEX HEAD CAP SCREW	B0605-1/2 17090	6
2 *	CART SEAL ASSY	46512-192	1	18	LOCK WASHER	J06 17090	6
3	ADJ SHIM SET	5091 17090	REF	19	BEARING CAP	38322-415 17040	1
4 *	OIL SEAL	S1917	1	20 *	O-RING	25154-252	1
5	SEAL PLATE	12350 1718H	1	21	RETAINING RING	S215	1
6 *	GASKET	12350G 19410	1	22 *	BALL BEARING	23422-412	1
7 *	OIL SEAL	S1917	1	23 *	KEY	N0616 17040	1
7A *	OIL SEAL	S1917	1	24 *	IMPELLER SHAFT	38515-588 1706H	1
8	PIPE PLUG	P04 17090	1	25 *	BALL BEARING	23421-461	1
8A	BRG CVTY DRAIN PLUG	P04 17090	1	26	SOCK HEAD CAP SCREW	DM1004S 17090	1
8B	SEAL CVTY DRAIN PLUG	P04 17090	1	27	IMPELLER WASHER	10278 17090	1
9	BEARING HOUSING	38251-518 17180	1	28 *	O-RING	25154-458	2
10	VENTED PIPE PLUG	4823A 17040	1	29	SHIPPING PLUG	11495B 15079	2
11	AIR VENT	26717-006	1	NOT SHOWN:			
12	REDUCER PIPE BUSHING	AP0802 17040	1		DRIVE SCREW	BM#04-03 17000	2
13	PIPE PLUG	P12 17090	1		S/N PLATE	2613GG 17020	1
14	SEAL CVTY SIGHT GAUGE	26714-021	1		ROT ASSY ADJ SHIM	33221-018 17040	12
14A	BRG CVTY SIGHT GAUGE	26714-021	1		INSTRUCTION TAG	6588U	1
15	HEX HEAD CAP SCREW	B1006 17090	4		ROTATION DECAL	2613M	1
16	LOCK WASHER	J10 17090	4				

* INDICATES PARTS RECOMMENDED FOR STOCK

COMPLETE GASKET/O-RING AND SHAFT REPAIR KITS AVAILABLE – CONSULT FACTORY.

PUMP AND SEAL DISASSEMBLY AND REASSEMBLY

Review all **SAFETY** information in Section A.

Follow the instructions on all tags, label and decals attached to the pump.

This pump requires little service due to its rugged, minimum-maintenance design. However, if it becomes necessary to inspect or replace the wearing parts, follow these instructions which are keyed to the illustrations (see Figures 1 and 2) and the accompanying parts lists.



This manual will alert personnel to known procedures which require special attention, to those which could damage equipment, and to those which could be dangerous to personnel. However, this manual cannot possibly anticipate and provide detailed instructions and precautions for every situation that might occur during maintenance of the unit. Therefore, it is the responsibility of the owner/maintenance personnel to ensure that only safe, established maintenance procedures are used, and that any procedures not addressed in this manual are performed only after establishing that neither personal safety nor pump integrity are compromised by such practices.

Many service functions may be performed by draining the pump and removing the back cover assembly. If major repair is required, the piping and/or power source must be disconnected. The following instructions assume complete disassembly is required.

Before attempting to service the pump, disconnect or lock out the power source and take precautions to ensure that it will remain inoperative. Close all valves in the suction and discharge lines.

For power source disassembly and repair, consult the literature supplied with the power source, or contact your local power source representative.



Before attempting to open or service the pump:

1. Familiarize yourself with this manual.
2. Disconnect or lock out the power source to ensure that the pump will remain inoperative.
3. Allow the pump to completely cool if overheated.
4. Check the temperature before opening any covers, plates, or plugs.
5. Close the suction and discharge valves.
6. Vent the pump slowly and cautiously.
7. Drain the pump.



Death or serious personal injury and damage to the pump or components can occur if proper lifting procedures are not observed. Make certain that hoists, chains, slings or cables are in good working condition and of sufficient capacity and that they are positioned so that loads will be balanced and the pump or components will not be damaged when lifting. Suction and discharge hoses and piping must be removed from the pump before lifting. Lift the pump or component only as high as necessary and keep personnel away from suspended objects.



This pump may be used to handle materials which could cause illness through direct exposure or emitted fumes. Wear

adequate protective clothing when working on the pump or piping.



Use **Only Genuine Gorman–Rupp** replacement parts. Failure to do so may create a hazard and damage the pump or diminish optimal pump performance. Any such hazard, damage or diminished performance is not covered by the warranty.

NOTE

When appropriate recycling facilities are available, the user should recycle components and fluids when doing any routine maintenance / repairs and also at the end of the pump's useful life. All other components and fluids shall be disposed of according to all applicable codes and regulations.

Back Cover and Wear Plate Removal

(Figure 1)

The wear plate (23) is easily accessible and may be serviced by removing the back cover assembly (27). Before attempting to service the pump, remove the pump casing drain plug (21) and drain the pump. Clean and reinstall the drain plug.

It is not necessary to remove the inspection cover (32) to service the wear plate (23). However, if the O-ring (37) requires replacement, remove the back cover nuts (36) and pull the inspection cover out of the back cover assembly (27). Replace the inspection cover O-ring and reinstall the inspection cover in the back cover assembly.

Remove the back cover nuts (31) and pry the back cover and assembled wear plate from the pump casing (1).

NOTE

An alternate method of removing the back cover from the pump casing is to remove the back cover nuts (31) and two diagonally opposing locking col-

lars (28). Install two 1/2–13 UNC x 2-inch long screws in the tapped holes in the back cover and use them to press the back cover out of the pump casing.

Inspect the wear plate and replace it if badly scored or worn. To remove the wear plate, disengage the hardware (12 and 25).

Inspect the back cover O-rings (24 and 26) and replace it if damaged or worn.

Suction Check Valve Removal

(Figure 1)

If the check valve assembly (41) is to be serviced, remove the check valve pin (40), reach through the back cover opening and pull the complete assembly from the suction flange (38).

NOTE

Further disassembly of the check valve is not required since it must be replaced as a complete unit. Individual parts are not sold separately.

Rotating Assembly Removal

(Figure 2)

The rotating assembly may be serviced without disconnecting the suction or discharge piping; however, the power source must be removed to provide clearance.

The impeller (1) should be loosened while the rotating assembly is still secured to the pump casing. Before loosening the impeller, remove the seal cavity drain plug (8B) and drain the seal lubricant. This will prevent the oil in the seal cavity from escaping when the impeller is loosened. Clean and reinstall the seal cavity drain plug.

Immobilize the impeller by wedging a block wood between the vanes and the pump casing and remove the impeller capscrew and washer (26 and 27).

Install the shaft key (23). Install a lathe dog on the drive end of the shaft (24) with the "V" notch positioned over the shaft key.

With the impeller rotation still blocked, see Figure 3 and use a long piece of heavy bar stock to pry against the arm of the lathe dog in a counterclockwise direction (when facing the drive end of the shaft). **Use caution** not to damage the shaft or keyway. When the impeller breaks loose, remove the lathe dog, key and wood block.

NOTE

Do not remove the impeller until the rotating assembly has been removed from the pump casing.

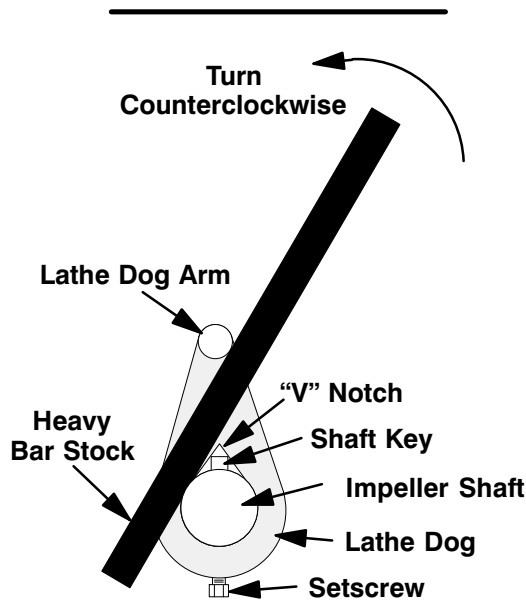

Figure 3. Loosening Impeller

(Figure 1)

Remove the inner hardware (12 and 14) from the casing ring (15). Install three of the inner cap-

screws in the jacking holes in the casing ring and use them to press the rotating assembly into the pump casing until the bearing housing is free.

Remove the jacking screws from the casing ring. Remove the outer hardware (12 and 13) and shims (11) and separate the casing ring from the pump casing. Tie and tag the shim sets for ease of reassembly.

An optional disassembly tool for removing and installing the rotating assembly is available from the factory. If the tool is used, follow the instructions packed with it. If improvised tools are used, be sure they are heavy enough for safe use and will not damage the pump.

After the rotating assembly is loosened, screw a 5/8-18 UNF X 16-inch long threaded rod into the impeller shaft. Support the drive end with another set of handles or a length of pipe (1-13/16 inch [46 mm] minimum I.D.) and slide the complete rotating assembly through the back cover opening (see Figure 4). Move the rotating assembly to a clean work area before proceeding with disassembly.

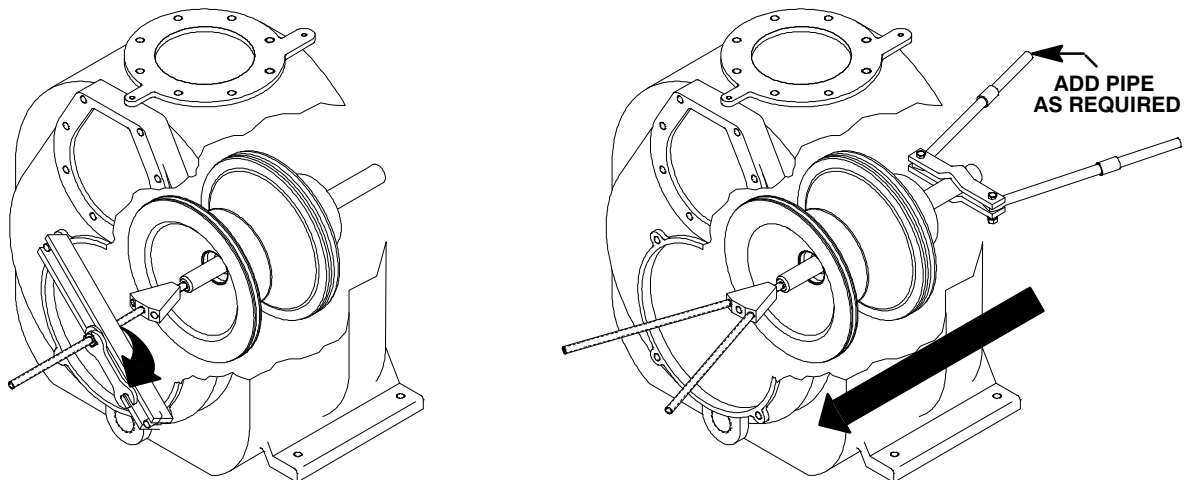

Figure 4. Rotating Assembly Removal

Remove the seal plate and bearing housing O-rings (17).

Impeller Removal

(Figure 2)

With the rotating assembly removed from the pump casing, unscrew the impeller from the shaft. Use caution when unscrewing the impeller; tension on the shaft seal spring will be released as the impeller is removed. Inspect the impeller and replace if cracked or badly worn.

Remove the impeller adjusting shims (3); tie and tag the shims, or measure and record their thickness for ease of reassembly.

Seal Removal

(Figure 2)

Slide the shaft sleeve and rotating portion of the seal off the shaft as a unit.

Use a pair of stiff wires with hooked ends to remove the stationary element and seat.

An alternate method of removing the stationary seal components is to remove the hardware (15 and 16) and separate the seal plate (5) and gasket (6) from the bearing housing (9). Position the seal plate on a flat surface with the impeller side down. Use a wooden dowel or other suitable tool to press on the back side of the stationary seat until the seat, O-rings, and stationary element can be removed.

If no further disassembly is required, refer to **Seal Installation**.

Shaft and Bearing Removal and Disassembly

(Figure 2)

When the pump is properly operated and maintained, the bearing housing should not require disassembly. Disassemble the shaft and bearings **only** when there is evidence of wear or damage.



Shaft and bearing disassembly in the field is not recommended. These operations should be performed only in a properly-equipped shop by qualified personnel.

Remove the bearing housing drain plug (8B) and drain the lubricant. Clean and reinstall the drain plug.

Disengage the hardware (17 and 18) and slide the bearing cap (19) and oil seal (7A) off the shaft. Remove the bearing cap O-ring (20) and press the oil seal from the bearing cap.

Place a block of wood against the impeller end of the shaft and tap the shaft and assembled bearings (22 and 25) from the bearing housing.

Pry or press the oil seals (4 and 7) from the bearing housing.

After removing the shaft and bearings, clean and inspect the bearings **in place** as follows.



To prevent damage during removal from the shaft, it is recommended that bearings be cleaned and inspected **in place**. It is **strongly** recommended that the bearings be replaced **any** time the shaft and bearings are removed.

Clean the bearing housing, shaft and all component parts (except the bearings) with a soft cloth soaked in cleaning solvent. Inspect the parts for wear or damage and replace as necessary.



Most cleaning solvents are toxic and flammable. Use them only in a well ventilated area free from excessive heat, sparks, and flame. Read and follow all precautions printed on solvent containers.

Clean the bearings thoroughly in **fresh** cleaning solvent. Dry the bearings with filtered compressed air and coat with light oil.



Bearings must be kept free of all dirt and foreign material. Failure to do so will greatly shorten bearing life. **Do not** spin dry bearings. This may scratch the balls or races and cause premature bearing failure.

Rotate the bearings by hand to check for roughness or binding and inspect the bearing balls. If rotation is rough or the bearing balls are discolored, replace the bearings.

The bearing tolerances provide a tight press fit onto the shaft and a snug slip fit into the bearing housing. Replace the bearings, shaft, or bearing housing if the proper bearing fit is not achieved.

If bearing replacement is required, remove the outboard bearing retaining ring (21) and use a bearing puller to remove the bearings from the shaft.

Shaft and Bearing Reassembly and Installation

(Figure 2)

Clean the bearing housing, shaft and all component parts (except the bearings) with a soft cloth soaked in cleaning solvent. Inspect the parts for wear or damage as necessary.



Most cleaning solvents are toxic and flammable. Use them only in a well ventilated area free from excessive heat, sparks, and flame. Read and follow all precautions printed on solvent containers.

Inspect the shaft for distortion, nicks or scratches, or for thread damage on the impeller end. Dress small nicks and burrs with a fine file or emery cloth. Replace the shaft if defective.

Position the inboard oil seal (7A) in the bearing housing bore with the lip positioned as shown in Figure 2. Press the oil seal into the housing until the face is **just flush** with the counterbored surface toward the inside of the bearing housing. Inspect for and remove any sealant shavings that might be removed from the O.D. of the oil seal.



To prevent damage during removal from the shaft, it is recommended that bearings be cleaned and inspected **in place**. It is **strongly** recommended that the bearings be replaced **any** time the shaft and bearings are removed.

The bearings may be heated to ease installation. An induction heater, hot oil bath, electric oven, or hot plate may be used to heat the bearings. Bearings should **never** be heated with a direct flame or directly on a hot plate.

NOTE

*If a hot oil bath is used to heat the bearings, both the oil and the container must be **absolutely** clean. If the oil has been previously used, it must be **thoroughly** filtered.*

Heat the bearings to a uniform temperature **no higher than 250°F (120°C)** and slide the bearings onto the shaft, one at a time, until they are fully seated. This should be done quickly, in one continuous motion, to prevent the bearings from cooling and sticking on the shaft.

NOTE

Position the inboard bearing (25) on the shaft as in-

indicated by the following illustration.

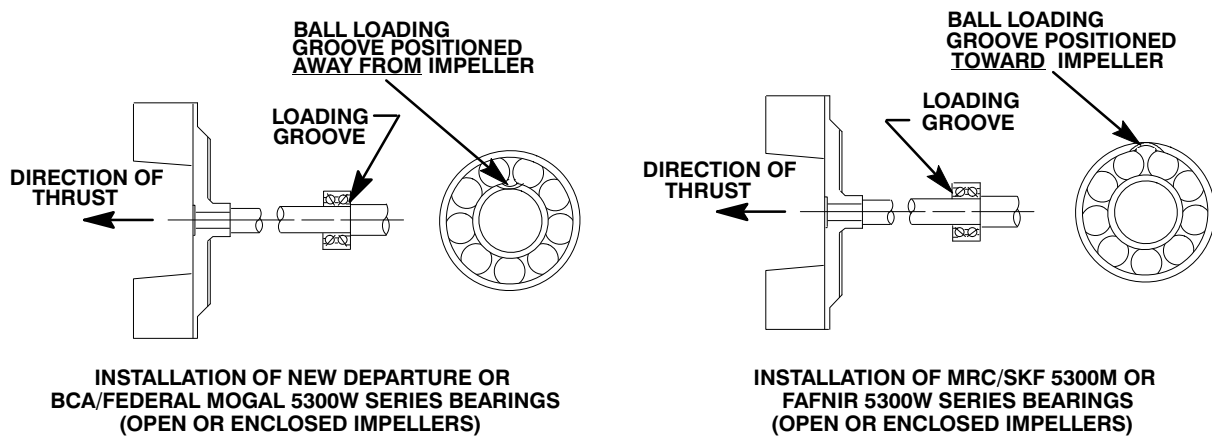
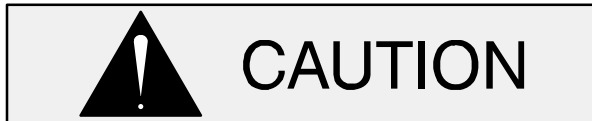

Figure 5. Inboard Bearing Positioning

After the bearings have been installed and allowed to cool, check to ensure that they have not moved away from the shaft shoulders in shrinking. If movement has occurred, use a suitably sized sleeve and a press to reposition the bearings against the shaft shoulders.

If heating the bearings is not practical, use a suitably sized sleeve and an arbor (or hydraulic) press to install the bearings on the shaft.



When installing the bearings onto the shaft, **never** press or hit against the outer race, balls, or ball cage. Press **only** on the inner race.

Secure the outboard bearing on the shaft with the bearing retaining ring (21).

It is recommended that a sleeve be positioned against the inboard oil seal (7) to prevent the lip of the oil seal from rolling as the shaft and bearings are installed in the bearing housing. The O.D. of the sleeve should be just smaller than the bearing housing bore, while the I.D. of the sleeve should be

just larger than the O.D. of the lip seal area of the shaft.

With the lip seal sleeve in place, lubricate the lip seal area of the shaft and slide the shaft and assembled bearings into the bearing housing until the retaining ring on the outboard bearing seats against the bearing housing. Remove the lip seal sleeve.



When installing the shaft and bearings into the bearing bore, push against the outer race. **Never** hit the balls or ball cage.

Position the outboard oil seal (4) on the lubricated shaft with the lip positioned as shown in Figure 2. Press the oil seal into the bearing housing until the face of the seal is just flush with the machined surface on the bearing housing.

Press the oil seal (7A) into the bearing cap (19) with the lip positioned as shown in Figure 2. Replace the bearing cap O-ring (20) and secure the bearing cap with the hardware (17 and 18). **Be careful** not to damage the oil seal lip on the shaft keyway.

Lubricate the bearing housing as indicated in **LUBRICATION**.

Seal Installation

(Figures 2 and 5)



Most cleaning solvents are toxic and flammable. Use them only in a well ventilated area free from excessive heat, sparks, and flame. Read and follow all precautions printed on solvent containers.

Clean the seal cavity and shaft with a cloth soaked in fresh cleaning solvent. Inspect the stationary seat bore in the seal plate for dirt, nicks and burrs, and remove any that exist. The stationary seat bore **must** be completely clean before installing the seal.



A new seal assembly should be installed **any time** the old seal is removed from the

pump. Wear patterns on the finished faces cannot be realigned during reassembly. Reusing an old seal could result in premature failure.

The seal is not normally reused because wear patterns on the finished faces cannot be realigned during reassembly. This could result in premature failure. If necessary to reuse an old seal in an emergency, **carefully** wash all metallic parts in fresh cleaning solvent and allow to dry thoroughly.

Inspect the seal components for wear, scoring, grooves, and other damage that might cause leakage. If any components are worn, replace the complete seal; **never mix old and new seal parts.**

If a replacement seal is being used, remove it from the container and inspect the precision finished faces to ensure that they are free of any foreign matter.

To ease installation of the seal, lubricate the shaft sleeve O-ring and the external stationary seat O-ring with a very **small** amount of "P-80[®] Emulsion" or water. See Figure 6 for seal part identification.

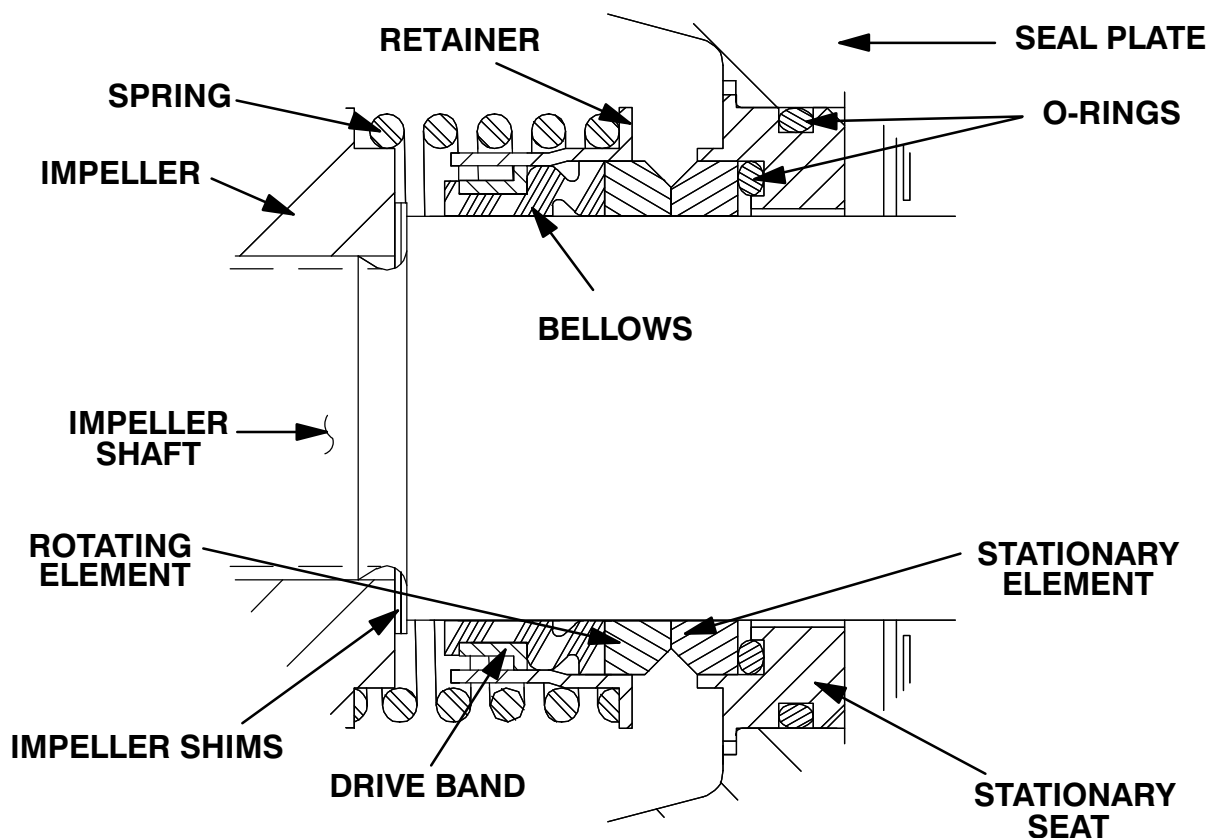

Figure 6. Seal Assembly



This seal is not designed for operation at temperatures above 160°F (71°C). Do not use at higher operating temperatures.

Lubricate the stationary seat O-rings with water or light oil, and install them in the stationary seat. Install the stationary seal element in the stationary seat. Press this stationary subassembly into the front of the seal plate (5) until it seats squarely against the bore shoulder.

Install the seal plate gasket (6). Position the seal plate and stationary seat over the shaft and secure it to the bearing housing (9) with the hardware (15 and 16). **Be careful** not to damage the stationary element on the shaft threads.

NOTE

It is recommended that a tapered sleeve be installed over the threads of the impeller shaft to ease installation of the rotating seal components.

Lubricate the shaft with water or a **small** amount of light oil and slide the rotating subassembly (consisting of the rotating element, bellows and retainer) onto the shaft. Apply firm, steady pressure on the seal retainer as it slides onto the shaft until the seal faces contact.

Install the seal spring. Lubricate the seal as indicated in **LUBRICATION** after the impeller is installed.

Impeller Installation and Adjustment

(Figure 2)

Inspect the impeller and replace it if cracked or badly worn. Inspect the impeller and shaft threads for dirt or damage, and clean or dress the threads as required.



The shaft and impeller threads **must** be completely clean before reinstalling the im-

PELLER. Even the slightest amount of dirt on the threads can cause the impeller to seize to the shaft, making future removal difficult or impossible without damage to the impeller or shaft.

Install the same thickness of impeller adjusting shims (3) as previously removed. Apply anti-seize (G-R P/N 18685—031) to threads. Install and fully tighten impeller prior to installing impeller washer and capscrew.

NOTE

At the slightest sign of binding, immediately back the impeller off, and check the threads for dirt. Do not try to force the impeller onto the shaft.

A clearance of .025 to .040 inch (0,64 to 1,02 mm) between the impeller and the seal plate is recommended for maximum pump efficiency. Measure this clearance, and add or remove impeller adjusting shims as required.

NOTE

If the rotating assembly has been installed in the pump casing, this clearance may be measured by reaching through the priming port with a feeler gauge.

*Proceed with **Rotating Assembly Installation** before installing the impeller capscrew and washer (26 and 27). The rotating assembly must be installed in the pump casing in order to torque the impeller capscrew.*

After the rotating assembly is installed in the pump casing, coat the threads of the impeller capscrew (26) with thread locker (G—R P/N 18771—109) and install the impeller washer (27) and capscrew; torque the capscrew to 90 ft. lbs. (1080 in. lbs. or 12,4 m. kg.).

Rotating Assembly Installation

(Figure 1)

Install the bearing housing and seal plate O-rings (17) and lubricate them with light grease. Slide the rotating assembly into the pump casing using the installation tool. **Be careful** not to damage the O-rings.

Install the pump casing ring (15) and secure it to the rotating assembly with the inner hardware (12 and 14).

NOTE

The inner capscrews are 1/4 inch (3,2 mm) shorter than the outer capscrews.

Install the rotating assembly shims (11) under the pump casing ring and secure the ring to the pump casing with the outer hardware (12 and 13).

To set the impeller and wear plate clearance, refer to the **Back Cover Installation and Adjustment**.

Suction Check Valve Installation

(Figure 1)

Inspect the check valve assembly (41) and replace it if badly worn.

NOTE

The check valve assembly must be replaced as a complete unit. Individual parts are not sold separately.

Reach through the back cover opening with the check valve and position the check valve adaptor in the mounting slot in the suction flange (38). Align the adaptor with the flange hole, and secure the assembly with the check valve pin (40).

NOTE

If the suction or discharge flanges were removed, replace the respective gaskets, apply 'Permatex Aviation No. 3 Form-A-Gasket' or equivalent compound to the mating surfaces, and secure them to the pump casing with the attaching hardware.

Back Cover Installation and Adjustment

(Figure 1 and 9)

If the wear plate (23) was removed for replacement, carefully center it on the back cover and secure it with the hardware (12 and 25). The wear plate **must** be concentric to prevent binding when the back cover is installed.

Clearance between the impeller and wear plate is adjusted using four adjusting screws and locking

collars. There are 18 detents on the I.D. of each locking collar. Indexing the collars one detent on the adjusting screws represents approximately .005 inch (0,13 mm) of wear plate clearance. The recommended clearance between the wear plate and the impeller is .010 to .020 inch (0,25 to 0,50 mm).

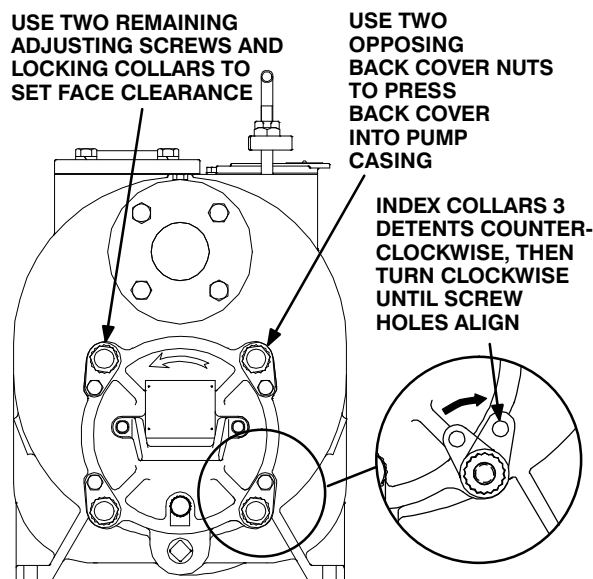

Figure 9. Installing and Adjusting Back Cover

Replace the back cover O-rings (24 and 26) and lubricate them with a generous amount of No. 2 grease. Clean any scale or debris from the contacting surfaces in the pump casing that might interfere or prevent a good seal with the back cover.

Screw the four adjusting screws (30) into the tapped holes in the back cover plate until they are **just flush** with the machined surface on the back side of the cover plate.

Align the back cover plate over the studs (22) and slide it into the pump casing. Use two back cover nuts (31) on diagonally opposing studs to press the back cover into the pump casing until the wear plate **just touches** the impeller when the shaft is turned by hand. **Tighten the back cover nuts evenly to avoid binding.**

With the wear plate just touching the impeller, turn the two free adjusting screws until they engage the pump casing. Position the locking collars over the adjusting screws so the holes in the collars for the locking screws align approximately with the holes in the cover plate.

Loosen the back cover nuts used to press the back cover into the pump casing one full turn.

Pull the collars off the adjusting screws, index them three detents counterclockwise, and reinstall the collars on the adjusting screws. Use the collars to turn the adjusting screws clockwise until the holes in the locking collars realign with the tapped screw holes in the back cover plate. Secure the locking collars (28) to the back cover plate with the hardware (12 and 29). Install the two remaining back cover nuts snugly against the adjusting screws.

Remove the first two back cover nuts from their studs. Turn the adjusting screws clockwise until they engage the pump casing. Install the locking collars (28) and hardware (12 and 29). Reinstall the back cover nuts.

Be sure the wear plate does not scrape against the impeller.

Over time it may be necessary to repeat the adjustment process to compensate for normal wear between the impeller and wear plate. When all of the adjustment has been used on the back cover side of the pump, an additional 0.125 inch (3,2 mm) of adjustment may be obtained by removing the rotating assembly adjusting shims (11).

Allow an installed pump to completely cool before draining liquid from the pump casing. Remove the back cover. Remove the rotating assembly adjusting shims, then reinstall the hardware securing the rotating assembly to the pump casing. Perform the back cover adjustment procedure described above to obtain the proper face clearance.

PRESSURE RELIEF VALVE MAINTENANCE

(Figure 1)

The back cover is equipped with a pressure relief valve (not shown) to provide additional safety for the pump and operator (refer to **Liquid Temperature and Overheating** in **OPERATION**).

It is recommended that the pressure relief valve assembly be replaced at each overhaul, or any time the pump overheats and activates the valve. **Never** replace this valve with a substitute which has not been specified or provided by the Gorman-Rupp Company.

Periodically, the valve should be removed for inspection and cleaning. When reinstalling the relief valve, apply 'Loctite Pipe Sealant With Teflon No. 592', or equivalent compound, on the relief valve threads. Position the valve as shown in Figure 1 with the discharge port pointing down.

Final Pump Assembly

(Figure 1)

Install the shaft key (23, Figure 2) and reconnect the power source. Be sure to install any guards used over the rotating members.



Do not operate the pump without the guards in place over the rotating parts. Exposed rotating parts can catch clothing, fingers, or tools, causing severe injury to personnel.

Install the suction and discharge lines and open all valves. Make certain that all piping connections are tight, properly supported and secure.

Be sure the pump and power source have been properly lubricated, see **LUBRICATION**.

Remove the fill cover assembly (10) and fill the pump casing with clean liquid. Reinstall the fill cover and tighten it. Refer to **OPERATION**, Section C, before putting the pump back into service.

LUBRICATION

Seal Assembly

(Figure 2)

Before starting the pump, remove the vented plug (10) and fill the seal cavity with approximately 92

ounces (2,7 liters) of SAE No. 30 non-detergent oil to the middle of the sight gauge (14) and maintain it at the middle of the gauge. Clean and reinstall the vented plug. Maintain the oil at this level.

Bearings

(Figure 2)

The bearing housing was fully lubricated when shipped from the factory. Check the oil level regularly through the sight gauge (14A) and maintain it at the middle of the gauge. When lubrication is required, add SAE No. 30 non-detergent oil through the hole for the air vent (11). **Do not** over-lubricate. Over-lubrication can cause the bearings to over-heat, resulting in premature bearing failure.

Under normal conditions, drain the bearing housing once each year and refill with approximately 16 ounces (0,5 liter) of clean oil. Change the oil more frequently if the pump is operated continuously or installed in an environment with rapid temperature change.



Monitor the condition of the bearing lubricant regularly for evidence of rust or moisture condensation. This is especially important in areas where variable hot and cold temperatures are common.

For cold weather operation, consult the factory or a lubricant supplier for the recommended grade of oil.

Power Source

Consult the literature supplied with the power source, or contact your local power source representative.

**For Warranty Information, Please Visit
www.grpumps.com/warranty
or call:
U.S.: 419-755-1280
Canada: 519-631-2870
International: +1-419-755-1352**

GORMAN-RUPP PUMPS