

INSTALLATION, OPERATION, AND MAINTENANCE MANUAL



ROTARY GEAR PUMPS

MODELS
GHS SERIES FLEXIBLE SEAL STAINLESS STEEL PUMPS D,G,J,N&R SIZES CONSTRUCTION CODE 9-B

GORMAN-RUPP PUMPS

www.grpumps.com

Register your new
Gorman-Rupp pump online at
www.grpumps.com

Valid serial number and e-mail address required.

RECORD YOUR PUMP MODEL AND SERIAL NUMBER

Please record your pump model and serial number in the spaces provided below. Your Gorman-Rupp distributor needs this information when you require parts or service.

Pump Model: _____

Serial Number: _____

TABLE OF CONTENTS

INTRODUCTION	PAGE I - 1
SAFETY - SECTION A	PAGE A - 1
INSTALLATION - SECTION B	PAGE B - 1
PUMP MODEL DESIGNATION	PAGE B-1
PREINSTALLATION INSPECTION	PAGE B-2
STORAGE	PAGE B-2
Flushing	PAGE B-2
PUMP INSTALLATION	PAGE B-3
Maximum Operating Parameters	PAGE B-3
Lifting	PAGE B-3
Positioning The Pump	PAGE B-3
Mounting	PAGE B-3
Piping	PAGE B-3
Temperature Control	PAGE B-4
Gauges	PAGE B-4
Strainers	PAGE B-4
Sealing	PAGE B-4
Valves	PAGE B-4
Barrier Liquids for 65E Cartridge Triple Lipseal	PAGE B-5
Barrier Liquids for Dual Mechanical Seals	PAGE B-5
ALIGNMENT	PAGE B-5
Coupled Drives	PAGE B-5
V-Belt Drives	PAGE B-6
V-BELT TENSIONING	PAGE B-6
General Rules of Tensioning	PAGE B-6
Tension Measurement	PAGE B-6
ELECTRICAL CONNECTIONS	PAGE B-9
OPERATION - SECTION C	PAGE C - 1
PUMP OPERATION	PAGE C-1
PRE-OPERATION	PAGE C-1
Before Starting the Pump	PAGE C-1
Checking Pump Rotation	PAGE C-1
STARTING	PAGE C-2
OPERATION	PAGE C-2
Liquid Temperature	PAGE C-2
Overheating	PAGE C-2
Checking Gauges	PAGE C-2
Strainer Check	PAGE C-2
Leakage	PAGE C-3
PRESSURE RELIEF VALVE ADJUSTMENT	PAGE C-3
Cracking Pressure	PAGE C-3
Complete By-Pass Pressure	PAGE C-3
STOPPING	PAGE C-3
TROUBLESHOOTING - SECTION D	PAGE D - 1
PREVENTIVE MAINTENANCE	PAGE D-4

TABLE OF CONTENTS

(continued)

PUMP MAINTENANCE AND REPAIR - SECTION E PAGE E - 1

PARTS KEY:

Typical GHS SST Pump Model	PAGE E-3
PUMP DISASSEMBLY	PAGE E-4
Pressure Relief Valve (10)	PAGE E-5
Optional Head Jacket	PAGE E-5
Rotor Adjusting Sleeve (07)	PAGE E-5
Coverplate Kit (11)	PAGE E-6
Head/Idler Kit (01 and 02)	PAGE E-6
Seal Removal (05)	PAGE E-6
Rotor/Shaft Removal (03)	PAGE E-7
Foot Bracket Kit (08)	PAGE E-7
Backhead Kit Removal (06)	PAGE E-7
Housing Assembly (04)	PAGE E-7
PUMP REASSEMBLY	PAGE E-7
Cleaning and Inspection	PAGE E-7
Bushing Preparation	PAGE E-8
Housing Assembly (04)	PAGE E-8
Backhead Kit (06)	PAGE E-8
Rotor/Shaft Assembly (03)	PAGE E-9
Seal Installation (05)	PAGE E-9
Head/Idler Kit (01 and 02)	PAGE E-9
Optional Head Jacket	PAGE E-9
Coverplate Kit (11)	PAGE E-10
Foot Bracket Kit (08)	PAGE E-10
Rotor Adjusting Sleeve (07)	PAGE E-10
SETTING END CLEARANCE	PAGE E-10
RELIEF VALVE DISASSEMBLY	PAGE E-12
RELIEF VALVE REASSEMBLY	PAGE E-12
Relief Valve Installation (10)	PAGE E-14

SEAL APPENDIX - SECTION F PAGE F-1

Standard 60 Seal Assembly	PAGE F-1
Positive Locking Tandem Mechanical Seal (Option 60S)	PAGE F-3
Double Positive Drive (Option 60J) Seal	PAGE F-6
Optional Packing Seal	PAGE F-9
Cartridge Seal (General)	PAGE F-12
Option 65E Cartridge Lip Seal ("D" Size Only)	PAGE F-15
Positive Locking Tandem Mechanical Sea ("D" Size Only)	PAGE F-17
Friction Drive Seal (Option 61J).....	PAGE F-21

O-RING APPENDIX - SECTION G PAGE G-1

O-Ring Information Chart	PAGE G-1
--------------------------------	----------

JACKETED HEAD/BACKHEAD APPENDIX - SECTION HPAGE H-1

Inlet and Outlet Location	PAGE H-1
---------------------------------	----------

INTRODUCTION

Thank You for purchasing a Gorman-Rupp Rotary Gear Pump. This manual is designed to help you achieve the best performance and longest life from your Gorman-Rupp Rotary Gear pump. **Read this manual** carefully to learn how to safely install, operate and repair your pump. Failure to do so could result in personal injury or damage to the pump.

This manual will alert personnel to known procedures which require special attention, to those which could damage equipment, and to those which could be dangerous to personnel. However, this manual cannot possibly provide detailed instructions and precautions for each specific application or for every situation that might occur during maintenance of the unit. Therefore, it is the responsibility of the owner, installer and/or maintenance personnel to ensure that applications and/or maintenance procedures not addressed in this manual are performed only after establishing that neither personal safety nor pump integrity are compromised by such applications or procedures.

In addition to this manual, a separate **Parts List** is shipped with the pump. Refer to the Parts List when ordering parts.

If your pump is furnished with a drive unit, refer to the drive unit manufacturer's installation and operation instructions in the literature accompanying the pump.

These pumps can transfer a wide range of light, medium, and heavy viscosity liquids, depending

on design and components. **Some models are not recommended for use with water; others when fitted with specific options, may be used with water; consult the factory.**

If there are any questions regarding the pump or drive unit which are not covered in this manual or in other literature accompanying this unit, please contact your Gorman-Rupp distributor or the Gorman-Rupp Company:

The Gorman-Rupp Company
P.O. Box 1217
Mansfield, Ohio 44901-1217
Phone: (419) 755-1011

or:

Gorman-Rupp of Canada Limited
70 Burwell Road
St. Thomas, Ontario N5P 3R7
Phone: (519) 631-2870

WARRANTY INFORMATION

The warranty provided with your pump is part of Gorman-Rupp's support program for customers who operate and maintain their equipment as described in this and the other accompanying literature. Please note that should the equipment be abused or modified to change its performance beyond the original factory specifications, the warranty will become void and any claim will be denied.

The following are used to alert personnel to procedures which require special attention, to those which could damage equipment, and to those which could be dangerous to personnel:



Immediate hazards which will result in severe personal injury or death. These instructions describe the procedure required and the injury which will result from failure to follow the procedure.



Hazards or unsafe practices which COULD result in severe personal injury or death. These instructions describe the procedure required and the injury which could result from failure to follow the procedure.

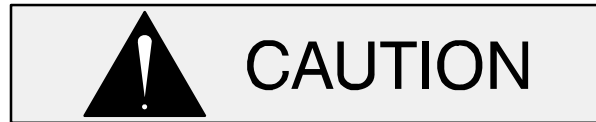

Hazards or unsafe practices which COULD result in minor personal injury or product or property damage. These instructions describe the requirements and the possible damage which could result from failure to follow the procedure.

NOTE

Instructions to aid in installation, operation, and maintenance or which clarify a procedure.

SAFETY - SECTION A

This information is specific to Gorman-Rupp GHS Series stainless steel Rotary Gear Pumps. It applies throughout this manual and any manual or literature accompanying the pump.

For information on the power unit used to drive this pump, consult the separate literature accompanying the power unit.

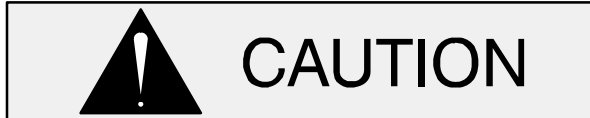

Pumps and related equipment must be installed and operated according to all national, local and industry standards.



This manual will alert personnel to known procedures which require special attention, to those which could damage equipment, and to those which could be dangerous to personnel. However, this manual cannot possibly provide detailed instructions and precautions for each specific application or for every situation that might occur during maintenance of the unit. Therefore, it is the responsibility of the owner, installer and/or maintenance personnel to ensure that applications and/or maintenance procedures not addressed in this manual are performed only after establishing that neither personal safety nor pump integrity are compromised by such applications or procedures.



Before attempting to install, operate, or service this pump, familiarize yourself with this manual, and with all other literature shipped with the pump. Unfamiliarity with all aspects of pump operation

covered in this manual could lead to destruction of equipment, injury, or death.



The standard version of this pump is designed to handle a wide range of light, medium, and heavy viscosity liquid, depending on design and components, and a range of temperatures when fitted with different seals. Do not apply at higher temperatures than the seal will handle. Do not attempt to pump liquids which may damage the pump or endanger personnel as a result of pump failure; consult the factory for chemical compatibility.



If the pump and motor are furnished mounted on a base, make certain that all lifting devices have adequate capacity. If chains or cables are used in lifting, make certain that they are positioned so as not to damage components, and so that the load will be balanced.



After the pump has been installed, make certain that the pump and all piping or hose connections are secure before operation. Loose connections can result in damage to the equipment and serious injury to personnel.



Never operate the pump without a pressure relief valve installed on the pump or in the discharge piping. Make certain that pump-mounted pressure relief

valves are installed with their adjusting ends toward the suction port. If bi-rotational operation is required, a pressure relief device must be provided for both directions of flow. Operation without a pressure relief valve or with an improperly installed relief valve could cause the pump to explode, resulting in serious injury or death to personnel.



Before attempting to open or service the pump:

1. Familiarize yourself with this manual.
2. Lock out incoming power to the drive unit to ensure that the pump will remain inoperative.
3. Allow the pump to completely cool if overheated.
4. Close the discharge and suction valve (if used).



An overheated pump can cause severe burns and injury. If overheating occurs:

1. Stop the pump immediately.
2. Allow the pump to completely cool.

3. Refer to the instructions in this manual before restarting the pump.



Do not remove plates, covers, gauges, pipe plugs or fittings from an overheated pump. Vapor pressure within the pump can cause parts being disengaged to be ejected with great force. Allow the pump to completely cool before servicing.



Do not operate this pump without guards in place over the rotating parts. Exposed rotating parts can catch clothing, fingers or tools, causing severe injury to personnel.



This pump may be used to handle liquids which may cause serious illness or injury through direct exposure or emitted fumes. Wear protective clothing, such as rubber gloves, face mask and rubber apron, as necessary, before disconnecting or servicing the pump or piping.

INSTALLATION - SECTION B

Review all SAFETY information in Section A.

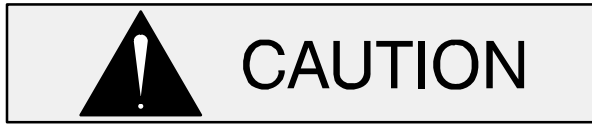

Pumps and related equipment must be installed and operated according to all national, local and industry standards.

Since pump installations are seldom identical, this section is intended only to summarize general recommendations and practices required to inspect, position, and arrange the pump and piping. If there are any questions concerning your specific installation, contact your Gorman-Rupp distributor or the Gorman-Rupp Company.

Most of the information applies to a flooded suction installation where liquid is supplied under pressure.

If the pump is positioned above the liquid in a static lift installation, information such as mounting, piping configuration and priming must be tailored to specific conditions.



These pumps are not recommended for use with water. Some models may be used with water when fitted with specific options; consult the factory.

PUMP MODEL DESIGNATION

Following is a description of the model numbering system for Gorman-Rupp rotary gear pumps. Rotary gear pump model numbers include design style, port size, hydraulic size and construction code.

Typical Pump Model

GHS	1 1/2	GF	32
⏟		⏟	
Design Style	Port Size	Hydraulic Size	Construction Code

Design Style: Gorman-Rupp rotary gear pumps are available in five basic designs:

- GMC – Medium Duty – Compact
- GMS – Medium Duty
- GHC – Heavy Duty – Compact
- GHS – Heavy Duty
- GHA – Abrasive Duty

Port Size: Gorman-Rupp rotary gear pumps are available in port sizes from 1 to 6 inches, depending on the design style. Consult your Gorman-Rupp distributor or the factory for additional sizes.

Hydraulic Size: The first letter in the hydraulic size is a rotor diameter code. The second letter indicates tooth length.

Construction Code: Construction Codes for Gorman-Rupp rotary gear pumps are as follows:

Code	Description
3	Iron w/Mechanical Seal(s)
4	Iron w/Packing or Lip Seal(s)
9	316 SST w/Mechanical Seal(s)
10	316 SST w/Packing or Lip Seal(s)
32	Steel w/Mechanical Seal(s)
38	Steel w/Packing or Lip Seal(s)

Theoretical Displacement: Table B-1 indicates theoretical displacement values for each hydraulic size.

NOTE

Actual capacities and recommended shaft speeds vary according to application. Consult your Gorman-Rupp distributor or the factory for additional information.

Table B-1. Theoretical Displacement

Hydraulic Size	Theoretical Displacement Per Revolution	
	Gallons	Centimeters ³
DC	0.00568	21.486
DE	0.00704	26.646
GC	0.00967	36.619
GF	0.01405	53.186
GH	0.01915	72.479
GJ	0.02317	87.700
JG	0.03579	135.49
JJ	0.05159	195.28
JL	0.07078	267.94
JP	0.10078	381.48
NK	0.10665	403.71
NM	0.14173	536.51
NP	0.17681	669.31
RM	0.24030	909.65
RP	0.29979	1134.8
RR	0.35927	1360.0
RS	0.41876	1585.1
SR	0.65752	2489.0
SU	1.10240	4173.2
TU	1.91280	7240.7

If the pump will not be immediately installed, follow these procedures or damage to the pump will occur.

- a. **Do not** flush the pump. Ensure that the port plugs shipped with the pump remain in place until piping is installed to help prevent dust or other foreign objects from entering the pump.
- b. Pumps that will not be installed for an extended period should be stored indoors if possible. The factory-installed port plugs will **not** ensure protection from excessive humidity, splash water or rain. In very humid or wet conditions, install air-tight plugs in the ports and fill the pump completely with a lubricating preservative liquid that is compatible with the liquid to be pumped.
- c. Pumps stored outdoors **must be fully preserved** as described above, **completely covered** with plastic or other water-tight material, and the covering anchored to ensure that it will not be blown off.

PREINSTALLATION INSPECTION

The pump assembly was inspected and tested before shipment from the factory. Before installation, check for damage which may have occurred during shipment. Check as follows:

- a. Inspect the pump assembly for cracks, dents, damaged threads, and other obvious damage.
- b. Check for loose attaching hardware. Since gaskets tend to shrink after drying, check for loose hardware at the mating surfaces.
- c. Carefully read all tags, decals, and markings on the pump assembly, and perform all duties indicated.

STORAGE



Due to the extreme close machining tolerances within rotary gear pumps, proper storage before installation is essential to prevent damage to the pump.

Flushing



Clean piping is essential because of close-tolerance moving parts in this pump. Flush all dirt, grit, weld beads or scale from the suction piping before installing the pump. Damage to the pump because of debris in the suction line is not covered by the pump warranty.

Before shipment, the pump may have been tested using a petroleum-based preservative. If flushing is required, do not do so until just before installation; the test oil protects close-tolerance pump parts from corrosion.



Most cleaning solvents are toxic and flammable. Use them only in a well ventilated area free from flame, sparks, and excessive heat. Read and follow all precautions printed on solvent containers.

NOTE

Simple flushing of the wetted end of the pump to remove test liquid may not be sufficient to thoroughly clean the seal cavity. Pump design and the particular seal assembly being used may require draining the seal area by removing the backhead plug and then flushing through a separate line.

To flush the pump, use an approved solvent compatible with the liquid being pumped. **Make certain that the solvent will not attack pump components, particularly seals and gaskets.**

PUMP INSTALLATION

Pump dimensions are shown in the separate Pump Specification Bulletin.



Never operate the pump without a pressure relief valve installed on the pump or in the discharge piping. Make certain that pump-mounted pressure relief valves are installed with their adjusting ends toward the suction port. If bi-rotational operation is required, a pressure relief device must be provided for both directions of flow. Operation without a pressure relief valve or with an improperly installed relief valve could cause the pump to explode, resulting in serious injury or death to personnel.

Maximum Operating Parameters

Rotary gear pumps are capable of different operating parameters depending on such things as specific materials of construction, pump options, liquid being pumped, etc. **In no case** should the application exceed the parameters shown below. Consult the factory for specific ratings.

* Maximum Operating Parameters	
Pressure	200 psi (28 Bar)
Speed	1750 rpm
Temperature	675 F (358 C)

* Consult Factory for Specific Ratings

Lifting

Remove suction and discharge hose and piping before attempting to lift the pump. Use lifting equipment with a capacity of at least five times the total weight of the equipment being lifted.

Positioning The Pump

Locate the pump as close as possible to the liquid being pumped. Locating the pump below the liquid source will help self-priming and reduce the possibility of cavitation.

Mounting

The pump may be shipped alone, mounted on a base, or with pump and motor mounted on a base. Install the pump and motor on a base before mounting the base on a foundation.

Mount the base on a foundation that will provide permanent, rigid support for the pump, and will be heavy enough to absorb any vibration, strain or shock.

Piping

Before establishing suction and discharge lines, determine pump port positions and rotation. Figure B-1 shows typical port positions for the standard 90 housing; if you have selected a 180 housing port option, your port positions will be different.

Either hose or rigid pipe may be used to make connections. If rigid piping is used, install expansion joints to protect the pump from vibration and thermal expansion in the piping. Do not use expansion joints or flexible connectors to adjust misaligned piping.

Begin piping layout at the pump, and work toward the source of supply and the point of discharge. If an obstacle is in the way of a suction or discharge line, run the piping **around** the obstruction, not over it. Running piping over an obstruction will create an air pocket which will make priming more difficult.

If possible, slope the piping toward the pump so no air or liquid is trapped in the piping. If a long horizontal suction line is necessary, install the line below the liquid level whenever possible in order to

keep the piping full of liquid. This will make priming easier because the pump will not have to remove as much air in the line.

ded that the jacket be plumbed with the incoming liquid entering the bottom of the jacket and exiting the top.

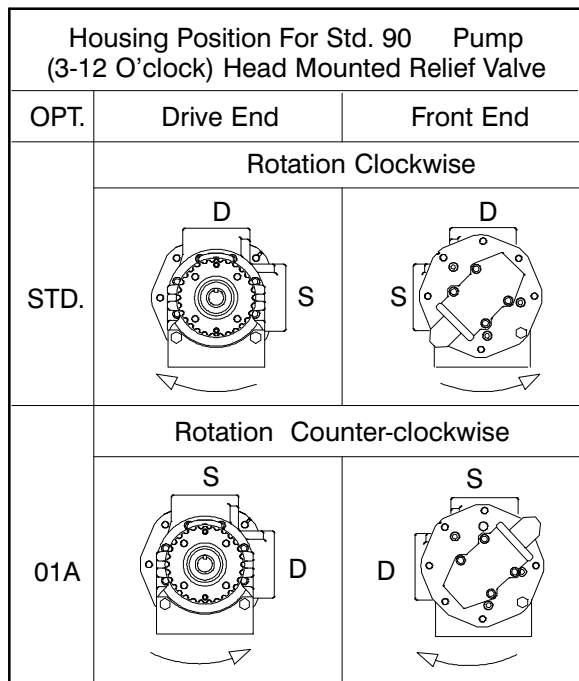

Figure B-1. Typical Port Positions & Rotation

The discharge and suction lines must be independently supported to avoid vibration and strain on the pump. For maximum pumping capacity, keep the lines as short and straight as possible. Elbows and fittings used in the lines increase friction losses; minimize their use. Reducers used in suction lines should be the eccentric type installed with the flat part uppermost to avoid creating air pockets.

Before tightening a connection or flange, align it exactly with the pump port. Never pull a pipe line into place by tightening the flange bolts and/or couplings.

Temperature Control

If your pump is equipped with temperature control jacket(s), follow the same guidelines described for suction and discharge piping installation when installing the temperature control piping. Be sure to install a shutoff valve in each supply line to the jacket(s) for serviceability.

To assist with air removal within the system and to improve heat transfer efficiency, it is recommen-



WARNING!

Liquid used for temperature control must not exceed 600 °F (316 °C) or 150 psi (1034 kPa) pressure. Higher temperatures or pressures can result in damage to the equipment and/or serious injury to personnel.

Gauges

Install a vacuum gauge in the suction line and a discharge pressure gauge in the discharge line (both should be as close as possible to the pump) to monitor operation and assist in troubleshooting.

Strainers

Because of the close-tolerance moving parts of this pump, it is recommended that a strainer be installed in the suction line. The strainer should be large enough to prevent excessive vacuum, and capable of operating under high vacuum without collapsing. The net open area of the strainer screen depends on liquid viscosity and desired flow rate; in any case, the sum of the area of all the holes in the screen should be three to five times the area of the suction pipe.

Sealing

Even a slight leak will affect priming, head, and capacity, especially in a suction lift application. Seal all piping joints, valves and gauges with pipe dope or teflon tape. The sealing material should be compatible with the liquid being pumped.

Valves

To avoid air pockets, install piping valves with the stem horizontal.

To prevent leakage during shutdown, install a shutoff valve in the discharge line, particularly on a flooded suction application. Shutoff valves are not recommended for suction lines.

It is **not** recommended that a foot valve be installed at the end of the suction line. If desired to install a foot valve, consult the factory.

When handling very hot or cold liquids, install a pressure relief valve in any part of the system that can be valved off or isolated; this will protect piping against damage from liquid thermal expansion or contraction from temperature changes during shutdown.

Barrier Liquids for 65E Cartridge Triple Lipseal

In general, a barrier liquid is **always** recommended for these seals. This requirement may be satisfied by a simple grease zerk, or it may become more complicated based on the application. The following barrier liquid guidelines are offered for maximum performance;

1. Select a clean, lubricating liquid that is compatible with the pumped product and with the pump construction (iron or 316 SST).
2. Depending upon pump shaft speed, a pressurized barrier liquid may not be required. Consult the factory for your specific application.

Barrier Liquids for Dual Mechanical Seals

Pumps equipped with dual mechanical seals require a barrier liquid to prevent contamination of the seal assembly by the liquid being pumped. The barrier liquid must have the following characteristics:

- a. The barrier liquid must have sufficient lubricating characteristics, including an optimum viscosity of 1 to 5 cSt at the temperature of the liquid being pumped.
- b. The barrier liquid must be compatible in all respects with cast iron.
- c. The barrier liquid must be compatible in all respects with the liquid being pumped.

Pumps equipped with dual mechanical seals require the barrier liquid to be supplied at a continuous pressure equivalent to the maximum discharge pressure in order to avoid inboard seal face

separation. The maximum barrier liquid pressure that can be applied depends primarily on the maximum seal design pressure (consult the factory).

Do not pressurize tandem seals. Pressurizing a tandem seal will cause the seal faces to separate, resulting in leakage and/or damage to the seal.

Refer to the appropriate section in **Seal Appendix, Section F** for your specific seal option for operating instructions for the barrier liquid reservoir kit.

ALIGNMENT



Make certain that power to the drive unit is disconnected before attempting to connect the pump drive; otherwise, personal injury may result.

NOTE

See **ROTATION** in Section C before mounting the pump on the base.

Coupled Drives

When using couplings, the axis of the power source must be aligned to the axis of the pump shaft in both the horizontal and vertical planes. Most couplings require a specific gap or clearance between the driving and the driven shafts. Refer to the coupling manufacturer’s service literature.

Align spider insert type couplings by using calipers to measure the dimensions on the circumference of the outer ends of the coupling hub every 90°. The coupling is in alignment when the hub ends are the same distance apart at all points (see Figure B-2).

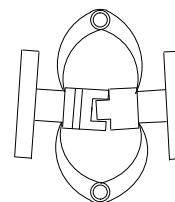

Figure B-2. Spider-type Couplings

Align non-spider type couplings by using a feeler gauge or taper gauge between the coupling halves every 90°. The coupling is in alignment when the hubs are the same distance apart at all points (see Figure B-3).

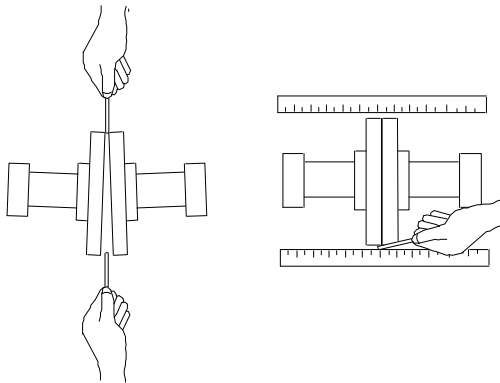

Figure B-3. Aligning Non-Spider Type Coupling

Check parallel adjustment by laying a straightedge across both coupling rims at the top, bottom, and side. When the straightedge rests evenly on both halves of the coupling, the coupling is in horizontal parallel alignment. If the coupling is misaligned, use a feeler gauge between the coupling and the straightedge to measure the amount of misalignment.

V-Belt Drives

When using V-belt drives, the power source and the pump must be parallel. Use a straightedge along the sides of the pulleys to ensure that they are properly aligned (see Figure B-4). In drive systems using two or more belts, make certain that the belts are a matched set; unmatched sets will cause accelerated belt wear.

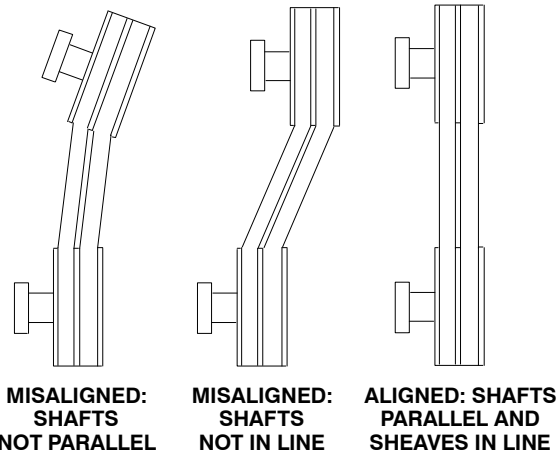

Figure B-4. V-belt Alignment

Tighten the belts in accordance with the belt manufacturer’s instructions. If the belts are too loose they will slip; if they are too tight, there will be excessive power loss and possible bearing failure.

Select pulleys to match the proper speed ratio; overspeeding the pump may damage both pump and power source.



WARNING!

Do not operate this pump without guards in place over the rotating parts. Exposed rotating parts can catch clothing, fingers or tools, causing severe injury to personnel.

V-BELT TENSIONING

General Rules of Tensioning

For new v-belts, check the tension after 5, 20 and 50 hours of operation and re-tension as required (see the following procedure for measuring belt tension). Thereafter, check and re-tension if required monthly or at 500 hour intervals, whichever comes first.

Ideal v-belt tension is the **lowest** tension at which the belt will not slip under peak load conditions. Do not over-tension v-belts. Over-tensioning will shorten both v-belt and bearing life. Under-tensioning will cause belt slippage. Always keep belts free from dirt, grease, oil and other foreign material which may cause slippage.

Tension Measurement

Correct v-belt tension can be achieved using a v-belt tension tester and Table B-2 or B-3. Use the tables to find the v-belt size (cross-section), the smallest sheave diameter, the belt type for your application. The corresponding deflection force required for new or used belts is shown opposite the RPM range of the pump.

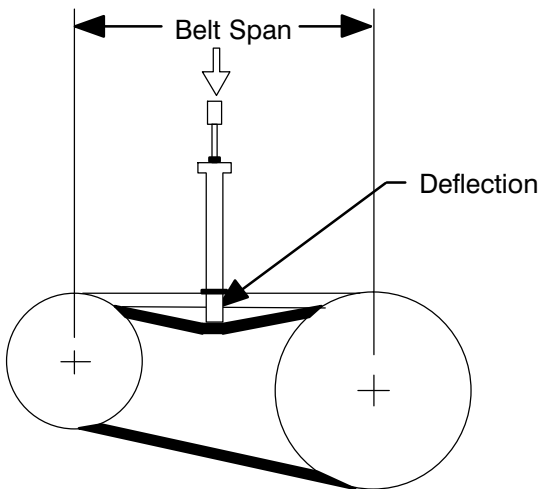

Figure B-5. Belt Tension Measurement

The ratio of deflection to belt span is 1:64 for both ASA and metric units. Therefore, a belt with a span of 64 inches would require a deflection of 1 inch at the force shown on the Tables for your particular application.

For example, if the span as measured in Figure B-5 is 32 inches (813 mm), the v-belt cross-section is C, the smallest sheave diameter is 8 inches, the pump speed is 1250 RPM, and the belts are uncogged Yy-T type, then 11.5 lbs. of force on the tensioner should show 1/2-inch (12,7 mm) of deflection.

A tension tester is available as an option from Gorman-Rupp (P/N 29513-001). Other tension testers are available from your local belt/sheave distributor, and work on a similar principal.

To use the Gorman-Rupp tensioner, measure the belt span as shown in Figure B-5. Position the bottom of the large O-ring on the span scale of the tensioner at the measured belt span. Set the small O-ring on the deflection force scale to zero.

Place the tension tester squarely on the belt at the center of the belt span. Apply force on the plunger, perpendicular to the belt span, until the bottom of the large O-ring is even with the top of the next belt, or with the bottom of a straight edge laid across the sheaves.

Read the force applied from the bottom of the small O-ring on the deflection force scale. Compare this force with the value shown in Table B-2 or B-3 and adjust the tension accordingly. Note that the **tension for new belts is higher than that for used belts** to allow for expected belt stretching. **Do not** over-tension used belts to the higher deflection forces shown for new belts.

**Table B-2. Sheave Diameter (In.)
Deflection Force (Lbs.)**

Cross Section	Smallest Sheave Diameter Range	R.P.M. Range	Belt Deflection Force			
			Uncogged Hy-T Belts & Uncogged Hy-T Torque Team		Cogged Torque-Flex & Machined Edge torque Team Belts	
			Used Belt	New Belt	Used Belt	New Belt
A,AX	3.0 - 3.6	1000-2500 2501-4000	3.7 2.8	5.5 4.2	4.1 3.4	6.1 5.0
	3.8 - 4.8	1000-2500 2501-4000	4.5 3.8	6.8 5.7	5.0 4.3	7.4 6.4
	5.0 - 7.0	1000-2500 2501-4000	5.4 4.7	8.0 7.0	5.7 5.1	9.4 7.4
B,BX	3.4 - 4.2	860-2500 2501-4000			4.9 4.2	7.2 6.2
	4.4 - 5.6	860-2500 2501-4000	5.3 4.5	7.9 6.7	7.1 7.1	10.5 9.1
	5.8 - 8.6	860-2500 2501-4000	6.3 6.0	9.4 8.9	8.5 7.3	12.6 10.9
C,CX	7.0 - 9.0	500-1740 1741-3000	11.5 9.4	17.0 13.8	14.7 11.9	21.8 17.5
	9.5 - 16.0	500-1740 1741-3000	14.1 12.5	21.0 18.5	15.9 14.6	23.5 21.6
D	12.0 - 16.0	200-850 851-1500	11.5 9.4	17.0 13.8	14.7 11.9	21.8 17.5
	18.0 - 20.0	200-850 851-1500	30.4 25.6	45.2 38.0		
3V, 3VX	2.2 - 2.4	1000-2500 2501-4000			3.3 2.9	4.9 4.3
	2.65 - 3.65	1000-2500 2501-4000	3.6 3.0	5.1 4.4	4.2 3.8	6.2 5.6
	4.12 - 6.90	1000-2500 2501-4000	4.9 4.4	7.3 6.6	5.3 4.9	7.9 7.3
5V, 5VX	4.4 - 6.7	500-1749 1750-3000 3001-4000			10.2 8.8 5.6	15.2 13.2 8.5
	7.1 - 10.9	500-1740 1741-3000	12.7 11.2	18.9 16.7	14.8 13.7	22.1 20.1
	11.8 - 16.0	500-1740 1741-3000	15.5 14.6	23.4 21.8	17.1 16.8	25.5 25.0
8V	12.5 - 17.0	200-850 851-1500	33.0 26.8	49.3 39.9		
	18.0 - 22.4	200-850 851-1500	39.6 35.3	59.2 52.7		

**Table B-3. Sheave Diameter (Mm.)
Deflection Force (Kg.)**

Cross Section	Smallest Sheave Diameter Range	R.P.M. Range	Belt Deflection Force			
			Uncogged Hy-T Belts & Uncogged Hy-T Torque Team		Cogged Torque-Flex & Machined Edge torque Team Belts	
			Used Belt	New Belt	Used Belt	New Belt
A,AX	75 - 90	1000-2500 2501-4000	1.7 1.3	2.5 1.9	1.9 1.5	2.8 2.3
	91 - 120	1000-2500 2501-4000	2.0 1.7	3.1 2.6	2.3 2.0	3.4 2.9
	125 - 175	1000-2500 2501-4000	2.4 2.1	3.6 3.2	2.6 2.3	4.3 3.4
B,BX	85 - 105	860-2500 2501-4000			2.2 1.9	3.3 2.8
	106 - 140	860-2500 2501-4000	2.4 2.0	3.6 3.0	3.2 3.2	4.8 4.1
	141 - 220	860-2500 2501-4000	2.9 2.7	4.3 4.0	3.9 3.3	5.7 4.9
C,CX	175 - 230	500-1740 1741-3000	5.2 4.3	7.7 6.3	6.7 5.4	9.9 7.9
	231 - 400	500-1740 1741-3000	6.4 5.7	9.5 8.4	7.2 6.6	10.7 9.8
D	305 - 400	200-850 851-1500	11.3 9.6	16.8 14.2		
	401 - 510	200-850 851-1500	13.8 11.6	20.5 17.2		
3V, 3VX	55 - 60	1000-2500 2501-4000			1.5 1.3	2.2 2.0
	61 - 90	1000-2500 2501-4000	1.6 1.4	2.3 2.0	1.9 1.7	2.8 2.5
	91 - 175	1000-2500 2501-4000	2.2 2.0	3.3 3.0	2.4 2.2	3.6 3.3
5V, 5VX	110 - 170	500-1749 1750-3000 3001-4000			4.6 4.0 2.5	6.9 6.0 3.9
	171 - 1275	500-1740 1741-3000	5.8 5.1	8.6 7.6	6.7 6.2	10.0 9.1
	276 - 400	500-1740 1741-3000	7.0 6.6	10.6 9.9	7.8 7.6	11.6 11.3
8V	315 - 430	200-850 851-1500	15.0 12.2	22.4 18.1		
	431 - 570	200-850 851-1500	18.0 16.0	26.8 23.9		

ELECTRICAL CONNECTIONS

Before connecting an electric motor to incoming power, check that the electrical service available matches the pump motor requirements stamped on the motor nameplate.



The electrical power used to operate this pump is high enough to cause injury or death. Obtain the services of a qualified electrician to make all electrical connections.



Do not install and operate a non-explosion proof motor in an explosive atmosphere. Install, connect, and operate the motor in accordance with The National Electrical Code and all local codes. If there is a conflict between the instructions in the manual accompanying the unit and The National Electrical Code or the applicable local code, The National or local code shall take precedence.

OPERATION - SECTION C

Review all **SAFETY** information in Section A.

Follow the instructions on all tags, labels and decals attached to the pump.

PUMP OPERATION



Never use a pressure relief valve to regulate liquid flow. Pressure relief valves are designed as safety devices only. Attempting to regulate flow with a pressure relief valve may cause the pump or piping to explode, causing severe personal injury or death.

PRE-OPERATION

Make certain that all instructions in **INSTALLATION**, Section B have been carried out.



The standard version of the pump is designed to handle a wide range of light, medium, and heavy viscosity liquids, depending on design and components. Do not operate the pump with higher liquid temperatures than what it was designed; otherwise, pump components and operation may be affected. For temperature range consult The Gorman-Rupp Company.

Before Starting the Pump



Never operate the pump against a closed suction or discharge valve. The pump will overheat, and may rupture or explode, causing personal injury or death.

Open all valves in the suction and discharge lines, and close all drain valves.

If your pump is equipped with a packing seal, loosen the gland nuts before starting until the packing gland may be moved slightly. If leakage seems excessive after starting, wait until the pump has run long enough to reach its normal operating temperature to adjust the gland nuts. Packing pumps **must leak slightly** to cool and lubricate the shaft and to allow the shaft to turn freely.

Consult the drive manufacturer's operating manual before attempting to start the drive.

In a suction lift application, fill the pump housing with liquid to seal clearances and to lubricate the pump.

Checking Pump Rotation

Correct rotation of your pump is shown on the pump serial plate or direction arrow plate.

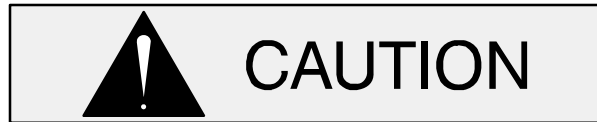

In applications with a single direction of flow and a single pump-mounted pressure relief valve, make certain that the drive unit turns the pump in the correct direction of rotation. Otherwise, the pump-mounted pressure relief valve will not function.

Follow the drive unit manufacturer's instructions, jog the pump motor **briefly**, and check rotation.

If a 3-phase motor is being used and rotation is incorrect, have a qualified electrician interchange any two of the 3-phase wires to change the direction of rotation. If a 1-phase motor is being used and rotation is incorrect, consult the motor manufacturer's literature.



Gorman-Rupp rotary gear pumps are bi-directional; however, the pumps are manufactured to rotate in one specific di-

rection. If rotation is to be changed, the pressure relief valve must be re-installed with the cap pointing toward the suction port. Additionally, if the discharge pressure is greater than the shaft seal rating (consult your Gorman-Rupp distributor), the pressure relief plugs in the back of the housing must be switched (see **Housing Assembly** under **PUMP REASSEMBLY**, Section E).

STARTING

Start the drive unit as indicated in the manufacturer's instructions and observe the suction and discharge gauges. If the pump does not deliver liquid within one minute, stop the drive unit. **Do not** operate the pump more than one minute without liquid in it; dry operation will damage or destroy the pump.

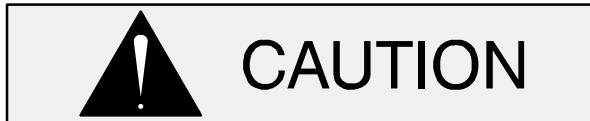

Although this pump is self-priming, never operate it dry. Dry operation could cause galling, seizing, damage to the seal or excessive wear of rotating parts.

Review the previous steps outlined in **PRE-OPERATION** and review **TROUBLESHOOTING**, Section D. If everything appears normal, add liquid to the pump housing to assist priming and start the driver again.

If the pump does not deliver liquid within two minutes, stop the pump; it may be necessary to vent the discharge line until liquid begins to flow.

If the pump still does not deliver after consulting **TROUBLESHOOTING** and venting the discharge line, contact your local Gorman-Rupp Rotary Gear Distributor or the factory.

OPERATION

NOTE

*If the pump malfunctions or does not meet operating specifications, refer to **TROUBLESHOOTING** – Section D.*

A change in operating noise when liquid first enters the pump is normal. After the pump is fully operational, monitor it for any unusual noises or vibration; if either occurs, shut the pump down immediately.

Liquid Temperature

Do not install the pump in a service with higher liquid temperatures than what it was designed. Introducing hot liquid into a cold pump will expand parts unevenly, causing excessive wear, pump failure, and operation may be affected. This thermal shock can be reduced by gradually heating the liquid being introduced into the pump. If it is not possible to heat the liquid, use heat tape and/or insulation to heat the pump.

High temperature bushings as well as optional jackets which may be used to heat or cool the pump are available options for many models.

Overheating

Overheating can occur if the pump is operated with valves in the suction or discharge lines closed. Operating against closed valves could bring the liquid to a boil, build pressure, and cause the pump to rupture or explode. If overheating occurs, stop the pump and allow it to completely cool before servicing.



Do not remove plates, covers, gauges, pipe plugs or fittings from an overheated pump. Vapor pressure within the pump can cause parts being disengaged to be ejected with great force. Allow the pump to completely cool before cooling.

Checking Gauges

Monitor vacuum and pressure gauge readings to ensure that the pump is operating within normal range and delivering full flow.

Strainer Check

If a strainer has been installed in the suction line, monitor vacuum gauge readings to detect blockage. Check the strainer if flow rate begins to drop.



WARNING!

Never introduce air or steam pressure into the pump housing to remove a blockage. This could result in personal injury or damage to the equipment. If backflushing is absolutely necessary, limit liquid pressure input to 50% of the maximum permissible operating pressure shown in the pump performance data.

Leakage

No leakage should be visible at pump mating surfaces or at pump connections or fittings. Keep all line connections and fittings tight to maintain maximum efficiency.

If your pump is equipped with a packing seal, the packing is lubricated by the liquid being pumped. Some leakage around the packing seal is normal. Packing pumps **must leak slightly** to cool and lubricate the shaft and to allow the shaft to turn freely.

Wait until the pump has run long enough to reach its normal operating temperature to adjust the gland nuts. Adjust the nuts only tight enough to reduce excessive leakage.

PRESSURE RELIEF VALVE ADJUSTMENT

Some pumps are not provided with a pressure relief valve. A pressure relief valve must be installed on the pump or in the discharge piping to ensure safe operation. Otherwise, the pump may be damaged and personnel injured.

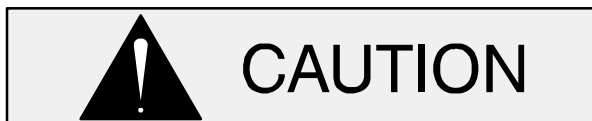

CAUTION

If operating at high temperatures, allow the pump to completely cool before attempting any adjustments.

Cracking Pressure

Cracking pressure is the pressure at which the pressure relief valve first begins to open and by-pass fluid. The nominal cracking pressure of the relief valve provided with this pump is set at the factory and is indicated on the tag attached to the relief valve.

If the nominal cracking pressure set at the factory must be changed, see Table E-2 and instructions in **Section E - MAINTENANCE AND REPAIR**.

Complete By-pass Pressure

Complete by-pass pressure is the maximum pressure the pump will see when all the pumped fluid is being by-passed through the pressure relief valve. This pressure will vary depending on the cracking pressure setting, liquid viscosity, and pump speed (pump capacity).

To determine the complete by-pass pressure, refer to the pump performance chart or consult the factory.



WARNING!

Do not remove the adjusting screw jam nut; with the jam nut removed the relief valve spring(s) can be compressed too far for the valve to open. If the valve does not open, excessive pressure can develop, causing damage to the pump and possible injury to personnel.

STOPPING

If the pump will be out of service for an extended length of time, particularly when handling non-lubricating liquids, drain the system and flush the pump and piping with an oil-based preservative to protect close-tolerance pump parts.

When handling liquids that solidify when at rest (tar, glue, etc.), flush the pump and piping with an approved solvent compatible with the pump components and the liquids being pumped.

TROUBLESHOOTING - SECTION D

Review all SAFETY information in Section A.



Before attempting to open or service the pump:

1. Familiarize yourself with this manual.
2. Allow the pump to completely cool if overheated.
3. Check the temperature before opening any covers, plates, or plugs.
4. Close the suction and discharge valves.
5. Drain the pump.

TROUBLESHOOTING WITH GAUGES

Most pump or system malfunctions can be detected by installing vacuum suction and discharge pressure gauges. Read the gauges and refer to the following information for interpretation of the gauge readings. For additional troubleshooting procedures, see the **TROUBLESHOOTING CHART**.

Vacuum Gauges

HIGH READING

- Suction valve closed, suction line blocked, foot valve jammed, strainer blocked.
- Liquid too viscous.
- Lift too high.
- Suction line undersized.

LOW READING

- Air leak in suction line.
- End of suction line not submerged.
- Pump parts worn or defective.
- End clearance too great.
- No liquid in pump housing.

ERRATIC READING

- Liquid overheated, vaporizing.
- Liquid entering intermittently, suction air leak, end of suction line not submerged.
- Vibration from cavitation, misalignment, damaged parts.

Pressure Gauges

HIGH READING

- Liquid too viscous.
- Discharge line undersized or too long.
- Discharge valve partially closed.
- Strainer blocked.
- Relief valve pressure set too high.
- Thermal changes in liquid.

LOW READING

- Relief valve pressure set too low.
- Internal valve not seating properly.
- Pump bypass partially open.
- End clearance too great.
- Pump parts worn or defective.

ERRATIC READING

- Cavitation.
- Liquid entering intermittently, suction air leak, end of suction line not submerged.
- Drive misalignment causing vibration.

TROUBLESHOOTING CHART

TROUBLE	POSSIBLE CAUSE	PROBABLE REMEDY
<p>PUMP FAILS TO PRIME OR LOSES PRIME</p>	<p>Internal clearance too great.</p> <p>Air leak in suction line; end of suction line not submerged; foot valve blocked or jammed; insufficient liquid in sump or tank.</p> <p>Suction strainer clogged.</p> <p>Shaft seal leaking; gaskets, O-rings worn.</p> <p>Leaking relief valve.</p> <p>Suction lift too high.</p> <p>Pump “starving” or liquid vaporizing in suction line.</p> <p>Pump rotation incorrect.</p> <p>Pump speed too slow.</p> <p>Housing dry.</p>	<p>Check and readjust clearance if required; see SETTING END CLEARANCE in Maintenance and Repair, Section E.</p> <p>Check and correct as required.</p> <p>Check strainer.</p> <p>Check vacuum gauge; disassemble pump and replace faulty parts.</p> <p>Disassemble and repair.</p> <p>See INSTALLATION, SECTION B and check piping.</p> <p>Increase suction pipe size or reduce length; position pump below liquid level.</p> <p>See OPERATION, SECTION C and check rotation.</p> <p>Check driver speed.</p> <p>Add liquid to housing, see OPERATION, SECTION C.</p>
<p>PUMP DOES NOT DELIVER RATED DISCHARGE OR CAPACITY</p>	<p>Air leak in suction line; end of suction line not submerged; foot valve blocked or jammed; insufficient liquid in sump or tank.</p> <p>Shaft seal leaking; gaskets, O-rings worn.</p> <p>Relief valve pressure set too low.</p> <p>Suction or discharge lines blocked; suction or discharge valves closed.</p> <p>Pump speed too slow.</p> <p>Pump “starving” or liquid vaporizing in suction line.</p> <p>Rotating parts worn or damaged; improper end clearance.</p>	<p>Check and correct as required.</p> <p>Check vacuum gauge; disassemble pump and replace faulty parts.</p> <p>Readjust.</p> <p>Check strainer, valves and piping.</p> <p>Check driver speed; check belts/couplings.</p> <p>Increase suction pipe size or reduce length; position pump below liquid level.</p> <p>Replace defective parts; see SETTING END CLEARANCE in Maintenance and Repair, Section E.</p>
<p>PUMP REQUIRES TOO MUCH POWER</p>	<p>Insufficient end clearances.</p> <p>Pump speed too high.</p> <p>Internal parts worn.</p> <p>Discharge line undersized and/or too long.</p>	<p>Readjust clearance; see SETTING END CLEARANCE in Maintenance and Repair, Section E.</p> <p>Reduce driver output.</p> <p>Disassemble pump and inspect.</p> <p>Increase size, decrease length.</p>

TROUBLESHOOTING CHART (Cont.)

TROUBLE	POSSIBLE CAUSE	PROBABLE REMEDY
PUMP REQUIRES TOO MUCH POWER (Cont.)	<p>Pump and/or drive mounting not secure; drive misaligned.</p> <p>Power source undersized.</p> <p>Lubrication required.</p> <p>Liquid in pump solidified.</p> <p>Insufficient internal clearances.</p>	<p>Tighten mounting hardware; realign drive.</p> <p>Check power requirements for application; resize as required.</p> <p>Add lubricant, as needed.</p> <p>Clear or heat.</p> <p>Consult factory.</p>
EXCESSIVE NOISE OR VIBRATION	<p>Pump and/or piping not secure; drive misaligned.</p> <p>Pumping entrained air.</p> <p>Pump "starving" or liquid vaporizing in suction line.</p> <p>Relief valve chatter.</p> <p>Rotating parts worn or damaged; improper end clearance.</p> <p>Pump operating outside designed operating range.</p> <p>Lubrication required.</p>	<p>Anchor base or piping, realign drive.</p> <p>Check liquid level.</p> <p>Increase suction pipe size or reduce length; position pump below liquid level.</p> <p>Increase pressure setting.</p> <p>Replace defective parts; check end clearance.</p> <p>Check discharge head and flow; adjust as required to meet performance specifications.</p> <p>Add lubricant, as needed.</p>
EXCESSIVE WEAR	<p>Corrosive liquid.</p> <p>Abrasive liquid.</p> <p>Contaminated liquid.</p> <p>Exceeding operating limits.</p> <p>Insufficient end clearance.</p> <p>Pump running dry.</p> <p>Pump and/or drive mounting not secure; drive misaligned; piping incorrectly installed.</p> <p>Insufficient lubrication.</p>	<p>Check local distributor or factory for parts compatibility with liquid; check liquid for contamination.</p> <p>Consult factory.</p> <p>Check liquid source; install strainer.</p> <p>Check performance data in Pump Specifications Bulletin.</p> <p>See SETTING END CLEARANCE in Maintenance And Repair, Section E.</p> <p>Add liquid to prime (See Operation, Section C); check liquid flow.</p> <p>Tighten mounting hardware; realign drive; check piping.</p> <p>Add lubrication and maintain at proper level.</p>

PREVENTIVE MAINTENANCE

Since pump applications are seldom identical, and pump wear is directly affected by such things as the abrasive qualities, pressure and temperature of the liquid being pumped, this section is intended only to provide general recommendations and practices for preventive maintenance. Regardless of the application however, following a routine preventive maintenance schedule will help assure trouble-free performance and long life from your Gorman-Rupp rotary gear pump. For specific questions concerning your application, contact your Gorman-Rupp distributor or the Gorman-Rupp Company.

Record keeping is an essential component of a good preventive maintenance program. The appearance of wearing parts should be documented at each inspection for later comparison. Also, if records indicate that a certain part (such as the seal) fails at the same duty cycle, this part can be checked and replaced before failure occurs.

Because of the tight tolerances within your rotary gear pump, wear between rotating parts is normal and expected. For new applications, a first inspection at 250 hours will give insight into the wear rate for your particular application. Subsequent inspections should be performed at regular intervals of 2000 hours. Critical applications should be inspected more frequently.

Check the thrust washer (medium duty models), idler bushing, idler pin, idler assembly, shaft bushing and rotor/shaft assembly at each inspection. Wear patterns should be uniform, without evidence of deep or irregular grooves.

For packing pumps, periodic adjustment of the packing is required to keep leakage to a minimum (see the adjustment procedure described under **Leakage in Operation, Section C**). Do not over-tighten. Replace the packing if leakage cannot be reduced by a slight adjustment.

If the pump is equipped with a backhead bearing (heavy duty models), inspect for free rotation of the shaft and rotor, and excessive endplay or radial movement of the shaft, which could indicate bearing wear. Remove the rotor adjusting sleeve assembly and inspect the bearing for damaged seals. Replacing the bearing at the first indication of a problem can extend the life of the pump and save considerable expense later to replace major components that can be damaged if the bearing is allowed to fail.

After extended service, adjustment of the clearance between the rotor and the head will normally improve performance (see the adjustment procedure in **Maintenance And Repair, Section E**).

If the pump is to be removed from service for repair, be sure to protect the internal components from rusting while the pump is disassembled and after reassembly if not immediately placed back into service.

Preventive Maintenance Schedule					
Item	Service Interval*				
	Daily	Weekly	Monthly	Semi-Annually	Annually
General Condition (Temperature, Unusual Noises or Vibrations, Cracks, Leaks, Loose Hardware, Etc.)	I				
Pump Performance (Gauges, Speed, Flow)	I				
Bearings				I	
Seal Lubrication (And Packing Adjustment, If So Equipped)		I			R
V-Belts (If So Equipped)			I		
End Clearance				I	
Pressure Relief Valve (If So Equipped)					C
Pump and Driver Alignment					I
Shaft Deflection					I
Piping					I
Driver Lubrication – See Mfgr’s Literature					

Legend:
 I = Inspect, Clean, Adjust, Repair or Replace as Necessary
 C = Clean
 R = Replace

* Service interval based on an intermittent duty cycle equal to approximately 4000 hours annually. Adjust schedule as required for lower or higher duty cycles or extreme operating conditions.

MAINTENANCE AND REPAIR - SECTION E

MAINTENANCE AND REPAIR OF THE WEARING PARTS OF THE PUMP WILL MAINTAIN PEAK OPERATING PERFORMANCE.

Pump Model

NOTE

*A separate **Parts List** is shipped with each pump. Below the pump model number on the **Parts List** is a grouping of several alpha-numeric codes. This code identifies the optional components of the pump. Contact the Gorman-Rupp Company to verify performance and options.*

The following illustrations cover disassembly and reassembly for the pump models shown below. Refer to the **Parts List** for your specific pump model.

The Following Pumps Are Covered By This Manual

**GHS SERIES FLEXIBLE SEAL
STAINLESS STEEL PUMPS
D,G,J,N&R SIZES
CONSTRUCTION CODE 9-B**

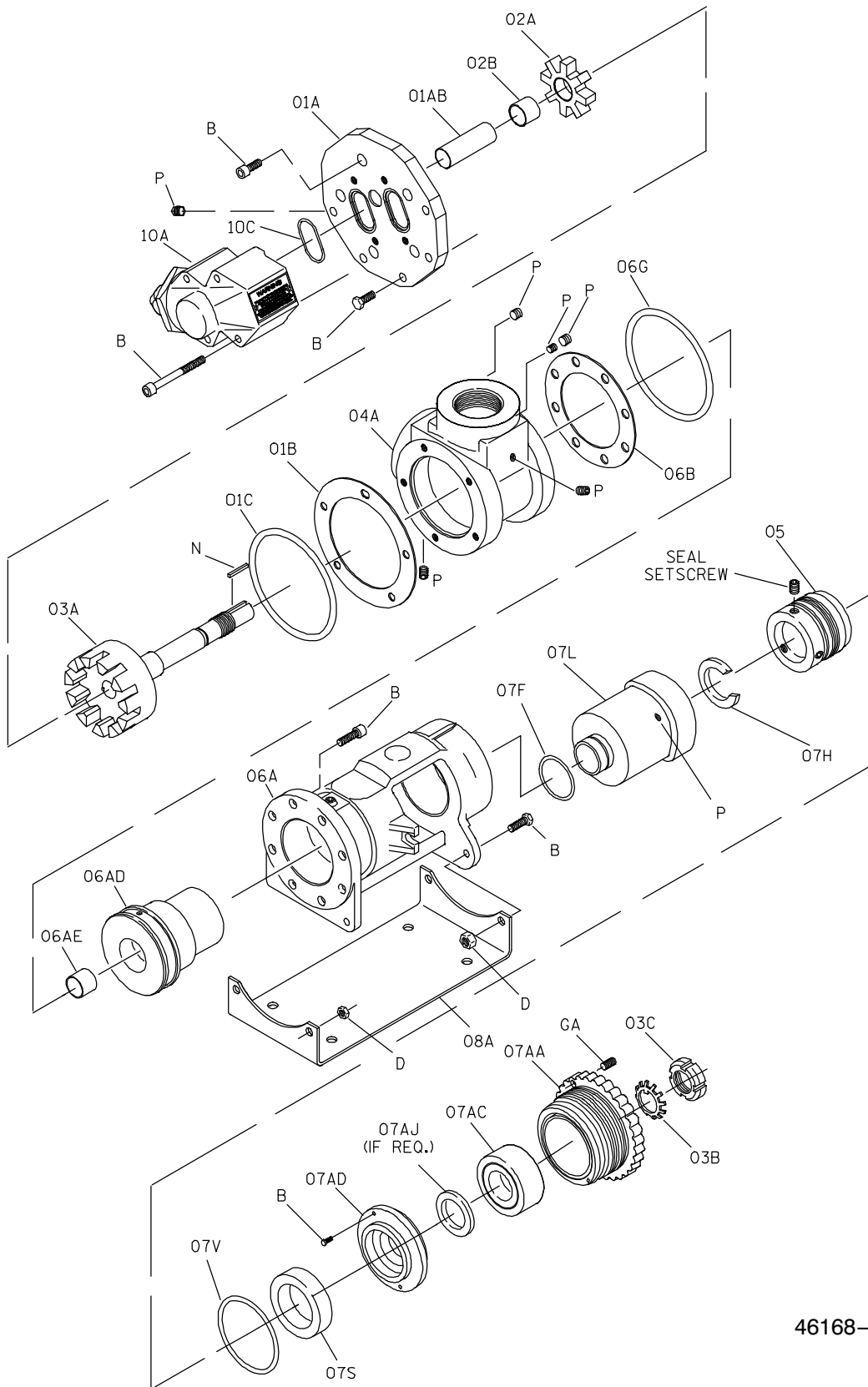

46168-052

Shown: Standard Model With 90 Ports, Head-Mounted Relief Valve and Optional Foot Bracket. Also Available With 180 Ports And/Or Housing-Mounted Relief Valve. A Coverplate Kit Replaces Either Relief Valve When Not Used.
NOTE: Refer to **Seal Appendix, Section F** for details of the seal assembly and related components.

Figure E-1. Typical GHS SST Pump Models

PARTS KEY FOR FIGURE E-1

Note: Item numbers cross reference to specific part numbers on the separate **Parts List**.

ITEM NO.	PART NAME	ITEM NO.	PART NAME
01	HEAD KIT	07AD	–BEARING RETAINING CAP
01A	–HEAD ASSEMBLY	07AJ	–BRG SPACER (IF REQ'D)
01AA	–HEAD	GA	–SOCKET HD SETSCREW
01AB *	–IDLER PIN	07B	–O-RING (IF REQ'D)
P	–PIPE PLUG	07F *	–O-RING
01C *	–O-RING	07H	–SHAFT CLIP (IF REQ'D)
B	–CAPSCREW	07L	–SEAT SLEEVE
01B *	HEAD GASKET	07V *	–SEAT SLEEVE O-RING
02	IDLER ASSEMBLY	08	FOOT BRACKET KIT
02A	–IDLER	08A	–FOOT BRACKET
02B *	–BUSHING	B	–CAPSCREW
		D	–NUT
03	ROTOR/SHAFT KIT	10	RELIEF VALVE KIT
03A	–ROTOR/SHAFT ASSEMBLY	10A	–RELIEF VALVE ASSEMBLY
03B *	–BEARING LOCKWASHER	10AA	–VALVE BODY
03C	–BEARING LOCKNUT	10AB	–WARNING PLATE
N	–SHAFT KEY	BM	–DRIVE SCREW
04	HOUSING ASSEMBLY	B	–CAPSCREW
04A	–HOUSING	10C *	–O-RING
P	–PIPE PLUG	10C *	–GASKET (OPTIONAL)
05 *	SEAL & RELATED COMPONENTS (SEE SECTION F)	12	NAMEPLATE KIT
		12A	–NAMEPLATE
		BM	–DRIVE SCREW
06	BACKHEAD KIT		NOT SHOWN: SECONDARY OR OPTIONAL SEAL (IF REQUIRED, SEE SECTION F)
06A	–BACKHEAD ASSEMBLY		
06AA	–BACKHEAD		
06AD	–BACKHEAD SLEEVE		
06AE *	–SHAFT BUSHING		
06AR	–O-RING (IF REQ'D)		
P	–PIPE PLUG	11	NOT SHOWN: HEAD COVERPLATE KIT (IF REQUIRED)
06B *	–GASKET	11A	–COVERPLATE ASSEMBLY
06G *	–O-RING	11AA	–COVERPLATE
B	–SOCKET HD CAPSCREW	11AC	–WARNING PLATE
07	ROTOR ADJUSTING SLEEVE KIT	BM	–DRIVE SCREW
07A	–ROTOR ADJUSTING SLEEVE ASSY	P	–PIPE PLUG
07AA	–ROTOR ADJUSTING SLEEVE	K	–WASHER
07AC *	–BALL BEARING	B	–CAPSCREW
		10C *	–O-RING OR GASKET

* INDICATES PARTS RECOMMENDED FOR STOCK

NOTE: Refer to **O-Ring Appendix, Section G** for O-ring identification and location.

PUMP DISASSEMBLY AND REASSEMBLY

Review all SAFETY information in Section A.

Follow the instructions on all tags, labels and decals attached to the pump.

This pump requires little service due to its rugged, minimum-maintenance design. However, if it becomes necessary to inspect or replace the wearing parts, follow these instructions which, unless otherwise specified, are keyed to the sectional view (see Figure E-1) and the accompanying parts key. Refer to the specific parts list accompanying your pump for part numbers.

In the following text, minor headings are followed by a number in parenthesis. This number represents the assembly for the item being discussed as identified in Figure E-1.

Before attempting to service the pump, disconnect the power source to ensure that it will remain inoperative. Remove the hardware securing the pump to the power source, and separate the power source and pump assembly. Retain all connection parts such as shaft keys, etc.

Close all valves in the suction and discharge lines. Disconnect the suction and discharge hose/piping.

For power source disassembly and repair, consult the literature supplied with the power source, or contact your local power source representative.



This manual will alert personnel to known procedures which require special attention, to those which could damage equipment, and to those which could be dangerous to personnel. However, this manual cannot possibly provide detailed instructions and precautions for each specific application or for every situation that might occur during maintenance of the unit. Therefore, it is the responsibility of the owner, installer

and/or maintenance personnel to ensure that applications and/or maintenance procedures not addressed in this manual are performed only after establishing that neither personal safety nor pump integrity are compromised by such applications or procedures.



Do not attempt to service the pump unless all power to the power source has been disconnected; otherwise, serious personal injury or death could result.



Use **Only Genuine Gorman-Rupp** replacement parts. Failure to do so may create a hazard and damage the pump or diminish optimal pump performance. Any such hazard, damage or diminished performance is not covered by the warranty.

NOTE

When appropriate recycling facilities are available, the user should recycle components and fluids when doing any routine maintenance / repairs and also at the end of the pump's useful life. All other components and fluids shall be disposed of according to all applicable codes and regulations.

PUMP DISASSEMBLY



Use caution when handling the idler (02A) and the rotor shaft assembly (03A). These parts have sharp edges which will grow sharper with use.

In the instructions which follow the **FRONT** is the head assembly end of the pump and the **REAR** is the drive (or backhead) end of the pump.

NOTE

It is strongly recommended that gaskets and O-

rings be replaced whenever the pump is reassembled.

When reinstalling pump components after disassembly, refer to Table E-1 for hardware torque specifications.

Bolt Dia. (Inches)	Torque (In. Lbs.)
1/4	120
5/16	216
3/8	264
7/16	588
1/2	876

Table E-1. Torque Specifications

Pressure Relief Valve (10)

If the pump is equipped with a pressure relief valve (10A), it can be mounted on either the head assembly (01A) or the housing assembly (04). Some models are equipped with one of each. Take note as to the direction in which the relief valve is mounted. To remove either style, remove the capscrews (B) securing the relief valve to the pump. The O-rings (10C) may remain in the head (01A) or in the housing (04A). Remove and discard the O-rings. For relief valve maintenance, see **RELIEF VALVE DISASSEMBLY** followed by **RELIEF VALVE REASSEMBLY** at the end of this section.

Optional Head Jacket

(Figure E-1 And E-2)

If your pump is equipped with an optional head jacket, see Figure E-2 and remove the capscrews (B) securing the head jacket (01G) and O-rings (01E) to the head assembly (01A, Figure E-1). Refer to Jacket Option Appendix H for Inlet and outlet location.

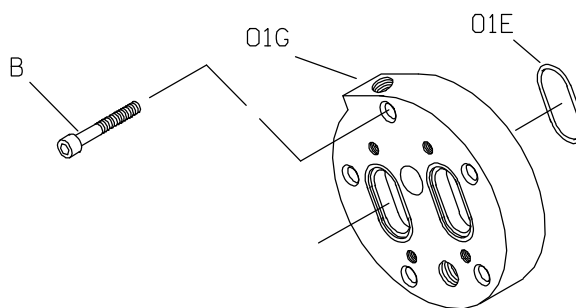

Figure E-2. Typical Head Jacket Assembly

Rotor Adjusting Sleeve (07)

Before attempting to remove the bearing locknut (03C), loosen the socket head setscrews (GA) securing the rotor adjusting sleeve (07) and use a pipe wrench or other suitable tool to turn the rotor adjusting sleeve clockwise (as viewed from the drive end) until the rotor binds against the head. This will prevent the rotor from turning as the locknut is unscrewed.

Straighten the tab on the bearing lockwasher (03B) and use a hammer and drift pin to loosen the bearing locknut until it can be unscrewed from the shaft. Remove the bearing lockwasher.

Unscrew the rotor adjusting sleeve kit from the backhead.

NOTE

Part or all of the seal assembly (05) will be removed with the rotor adjusting sleeve. Check the **Parts List** furnished with your pump to identify the seal, refer to **Seal Appendix, Section F**, for removal of the seal and related components, then proceed as follows with rotor adjusting sleeve disassembly.



When removing or installing the bearing (07AC), never hit or press against the inner race. Press **only** against the outer race.

Disengage the hardware (B) and remove the bearing retaining cap (07AD) and bearing spacer (07AJ, if used) from the rotor adjusting sleeve (07AA).

The bearing (07AC) is a light press fit into the rotor adjusting sleeve and can usually be removed with thumb pressure only. If the bearing does not come out easily, use a suitably sized sleeve and a mallet to lightly tap the bearing from the bore.

NOTE

Pumps equipped with seal options 60J (Double Positive Drive Seal) or 60S (Positive Locking Tandem Mechanical Seal) use a threaded bearing retaining nut to secure the bearing in the rotor adjusting sleeve. To remove the retaining nut, secure the rotor adjusting sleeve (07AA) in a vice with the drive side down. Position a screwdriver or other suitable tool horizontally through the slots in the bearing retaining nut and use the screwdriver to unscrew the bearing retaining nut from the rotor adjusting sleeve.

Refer to **Cleaning and Inspection** in this section before reassembling the rotor adjusting sleeve.

Coverplate Kit (11)

(Figure E-2 And E-3)

The coverplate kit may be mounted on either the head assembly or the housing assembly. Removal is the same for either.

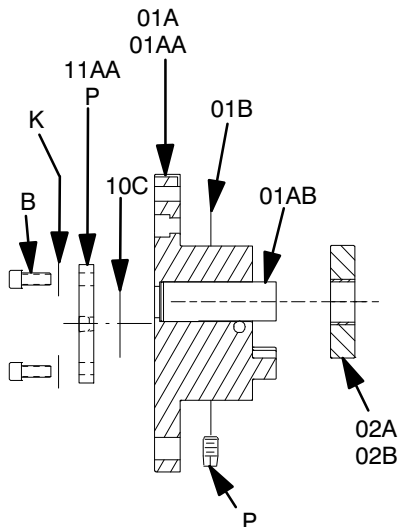

Figure E-3. Head Coverplate Kit, Head Kit And Idler Disassembly

Remove the hardware (BD and K) securing the coverplate (11AA) to the head (01AA) or housing (04A). The O-rings (10C) may remain in the head or housing. Remove and discard the O-rings.

Head/Idler Kit (01 and 02)

(Figure E-1 And E-3)

Remove the hardware (B) securing the head jacket (01G, optional) and/or head assembly (01A) to the housing (04A). Separate the head jacket from the head assembly. Remove and discard the O-rings (10C) and gasket (01B).



Use caution to prevent the idler assembly from dropping off the idler pin; the idler may be damaged if it falls on a hard surface.

Pull the head assembly (01A) from the housing assembly (04A, Figure E-1). Take care not to let the idler assembly (02) slide off the idler pin (01AB).

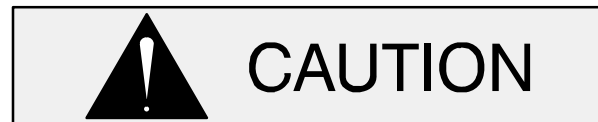

Use caution when handling the idler (02A) and the rotor shaft assembly (03A). These parts have sharp edges which will grow sharper with use.

NOTE

The idler bushing (02B) may be damaged during removal. Do not remove the idler bushing unless replacement is required.

Remove the assembled idler (02) from the head assembly. Inspect the idler bushing (02B) for excessive wear or scoring. If replacement is required, use an arbor (or hydraulic) press to remove the idler bushing (02B) from the idler (02A).

To remove the idler pin (01AB), lay the head assembly (01A) on an arbor (or hydraulic) press with the idler pin (01AB) facing down and remove the idler pin (01AB) from the head (01AA).

Seal Removal (05)

The seal assembly (05) is available in a variety of configurations. Check the **Parts List** furnished with your pump to identify the seal, then refer to **Seal Appendix, Section F**, for removal of the seal and related components.

Rotor/Shaft Removal (03)

With the seal removed, simply slide the rotor/shaft assembly (03A) out of the housing (04A). Due to close machine tolerances and assembly practices, the rotor/shaft is available only as an assembly. Further disassembly is not required.

Foot Bracket Kit (08)

Remove the hardware (B and D) securing the foot bracket (08A) to the head (01AA) and the backhead (06AA).

Backhead Kit Removal (06)

(Figures E-1 and E-4)

Remove the screws (B) securing the backhead assembly (06A) to the housing assembly (04), and separate the assemblies. Remove and discard the gasket (06B) or O-ring (06G).

NOTE

The shaft bushing (06AE) may be damaged during removal. Do not remove the throttle bushing unless replacement is required. Due to tight tolerances, the throttle bushing sleeve (06AD) must be removed from the backhead in order to replace the shaft bushing (06AE).

Use an arbor (or hydraulic) press and a suitably sized dowel to press the throttle bushing sleeve from the backhead.

Use an arbor (or hydraulic) press and a suitably sized dowel to press the throttle bushing out of the throttle bushing sleeve.

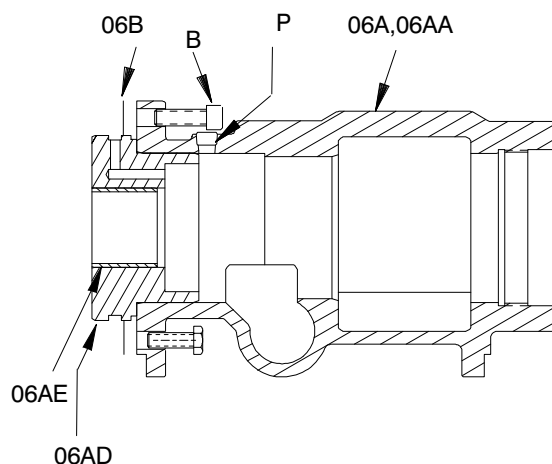

Figure E-4. Backhead

Housing Assembly (04)

NOTE

Seal cavity pressure relief is accomplished using socket head pipe plugs (P) in the back side of the housing. Removal of the plugs is not required unless the direction of pump rotation is to be changed.

If pump rotation is to be changed, remove the socket head pipe plugs (P) from the housing. The hole adjacent to the discharge port will have a small pipe plug under the larger, outer pipe plug. This plug must be removed and relocated to the suction side of the pump.

PUMP REASSEMBLY



Use caution when handling the idler (02A) and the rotor shaft assembly (03A). These parts have sharp edges which will grow sharper with use.

Cleaning and Inspection



Most cleaning solvents are toxic and flammable. Use them only in a well ventilated area free from flame, sparks, and excessive heat. Read and follow all precautions printed on solvent containers.

Clean and inspect the pump parts (except the bearing and seal assembly) with a cloth soaked in fresh cleaning solvent. Inspect all parts for excessive wear or for any nicks or burrs. Remove nicks or burrs using emery cloth or a fine file. Replace any parts that are badly worn or damaged.

Clean the bearing in fresh cleaning solvent and coat with light oil.

Rotate the bearing by hand to check for roughness or binding. If rotation is rough or there is any side-to-side movement between the inner and outer races, replace the bearing.



The bearing is permanently sealed and requires no additional lubrication except a coating of light oil on external surfaces to ease reassembly. External surfaces must be kept free of all dirt and foreign material. Failure to do so could damage the bearing or its mating surfaces.

The bearing tolerance provides a light press fit into the rotor adjusting sleeve (07AA). Replace the rotor adjusting sleeve if the proper fit is not achieved.

Clean and inspect the seal assembly as indicated in the appropriate section of the **Seal Appendix, Section F**.

Bushing Preparation

When replacing bushings, lightly oil the O.D. of the replacement bushing before installation.



Be very careful when installing graphite bushings. Graphite is extremely brittle and will crack if improperly installed. Use a press to install the bushing with one continuous motion until the bushing is fully seated. Stopping in mid-stroke will cause the bushing to crack. After installation, check the bushing for cracks.

NOTE

When installing **high temperature graphite bushings**, heat the part that receives the bushing to 500 F and place the bushing in a freezer for at least one hour. This will allow easier installation with less chance of breakage.

Housing Assembly (04)

Inspect and clean the housing (04A) with a cloth soaked in fresh cleaning solvent. Replace it if badly worn or damaged.



Most cleaning solvents are toxic and flammable. Use them only in a well ventilated area free from flame, sparks, and excessive heat. Read and follow all precautions printed on solvent containers.



If the socket head pipe plugs (P) in the back side of the housing were removed in order to change the direction of pump rotation, the smaller diameter plug **must** be installed in the hole adjacent to the discharge port of the housing. Otherwise, over-pressurization of the seal cavity could result in premature seal failure.

If the socket head pipe plugs (P) in the back side of the housing were removed, install the smaller diameter plug in the hole adjacent to the discharge port, and install one of the larger diameter pipe plugs over the smaller one. Install the second large pipe plug in the other hole in the back of the housing adjacent to the suction port.

Backhead Kit (06) (Figures E-1 and E-5)

Use an arbor (or hydraulic) press and a suitably sized dowel to press the throttle bushing (06AE) into the throttle bushing sleeve (06AD) until it is flush with the face of the sleeve.

Position the backhead (06AA) on the bed of an arbor (or hydraulic) press with the rotor end facing up. Use an arbor (or hydraulic) press and a suitably

sized dowel to install the assembled throttle bushing sleeve and throttle bushing in the backhead until fully seated.

Install a new gasket (06B) over the throttle bushing sleeve (06AD).

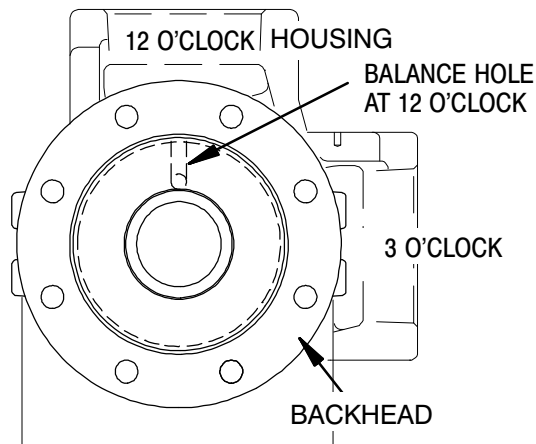

Figure E-5. Housing/Backhead Alignment

Position the balance hole as shown in Figure E-5, and secure the backhead assembly (06) to the housing (04) with the capscrews (B).

Secure the foot bracket (08A) to the backhead assembly (06) with the previously removed hardware (B and D).

Rotor/Shaft Assembly (03)

Inspect the rotor/shaft assembly (03A) for excessive wear, scoring or scratches along the shaft sealing surface. If replacement is required, the shaft and rotor must be replaced as an assembly. Small scratches can be dressed with a fine file or emery cloth. Replace the rotor/shaft assembly or any other parts if wear or damage is extensive.

Slide the rotor/shaft assembly into the housing and backhead. **Use caution** not to scratch or chip the I.D. of the bushing (06AE).

Seal Installation (05)

The seal assembly (05) is available in a variety of configurations. Check the **Parts List** furnished with your pump to identify the seal, then refer to **Seal Appendix, Section F**, for installation of the seal and related components.

Head/Idler Kit (01 and 02)

(Figure E-1 And E-3)

If the idler pin (01AB) was removed, apply “Loctite PST No. 565” pipe sealant with teflon (or equivalent compound) to the O.D. of the replacement idler pin and the I.D. of the idler pin bore in the head (01AA). Position the pin in the head with the chamfered side toward the head and the milled flat side facing the crescent. (If the pin is stepped, position it with the large chamfered end toward the head.) Use an arbor (or hydraulic) press to press the pin into the head until it bottoms out.

NOTE

When properly installed, the pin will be positioned 0.010 inch below the surface of the crescent.

If removed, install the pipe plug (P) in the hole in the suction side of the head (01AA).

Lightly oil the I.D. of the idler (02A), and use an arbor (or hydraulic) press to install the idler bushing (02B) in the idler. The bushing should be centered at both ends of the idler.

Place the head (01A) on a flat surface. Lightly oil the idler bushing (02B) and pin (01AB); install the idler assembly (02) on the pin. Spin the idler to make certain that it moves freely on the pin.

Install the head gasket (01B) over the head. Carefully position the head and idler against the housing and engage the idler and rotor/shaft assembly (03A). Turn the rotor/shaft until the idler and rotor teeth engage. **Do not force.**

Slide the head into the housing assembly. Rotate the head (01AA) until the groove in the head matches the groove in the housing. Secure the head to the housing with the capscrews (B).

Optional Head Jacket

(Figure E-1 And E-2)

If your pump is equipped with an optional head jacket, see Figure E-2 and install the O-rings (01E) in the grooves in the head (Figure 1, 01A).

NOTE

The O-rings (01E) that are installed between the head jacket (01G) and the head (Figure 1, 01A) are

coated with PTFE (DuPont Teflon or equivalent).

Install the head jacket gasket (01F) and secure the head jacket to the head with the capscrews (B).

Coverplate Kit (11)

(Figures E-1 and E-3)

The coverplate kit may be mounted on either the head assembly or the housing assembly on some optional pumps. Installation is the same for either.

Lightly lubricate the O-rings (10C) with oil and install them in the head (01A). Secure the coverplate (11AA) with the hardware (B). Be sure that the warning plate (11AC) is attached to the coverplate.

Foot Bracket Kit (08)

Secure the foot bracket (08A) to the head (01A) and backhead assembly (06A) with the hardware (B and D).

Rotor Adjusting Sleeve (07)

Clean the rotor adjusting sleeve and all component parts as described in **Cleaning and Inspection**. Inspect the parts for wear or damage and replace as necessary.

Use an arbor (or hydraulic) press and install the bearing in the rotor adjusting sleeve (07A) until it bottoms out on the shoulder of the rotor adjusting sleeve.

Install the bearing spacer (07AJ, if used). Install the bearing retaining cap (07AD) and secure it to the rotor adjusting sleeve with the hardware (B). Tighten the capscrews (B) until snug, then fully tighten in a cross-sequence.

NOTE

Pumps equipped with seal options 60J (Double Positive Drive Seal) or 60S (Positive Locking Tandem Mechanical Seal) use a threaded bearing retaining nut to secure the bearing in the rotor adjusting sleeve (07AA). When installing the retaining nut in the rotor adjusting sleeve, apply 1 to 2 drops of "Loctite Thread Locker No. 272" or equivalent compound to the threads of the bearing retaining nut and screw the nut into the rotor adjusting sleeve un-

til fully seated against the bearing.

NOTE

*Part or all of the seal assembly (05) must be installed with the rotor adjusting sleeve. Check the **Parts List** furnished with your pump to identify the seal, refer to **Seal Appendix, Section F**, for installation of the seal and related components, then proceed as follows with rotor adjusting sleeve installation. **Use caution** not to damage seal parts when installing the rotor adjusting sleeve.*

Loosen the socket head setscrews (GA). Slide the rotor adjusting sleeve kit over the shaft. Use caution not to damage installed seal components on the shaft. Screw the rotor adjusting sleeve into the backhead until the rotor bottoms against the head.



It is recommended that a new bearing lock washer (03B) be installed any time the rotor adjusting sleeve is disassembled. Re-use of an old lockwasher may create a pre-load condition on the bearing, resulting in premature bearing failure.

Install a new bearing lock washer (03B) and screw the bearing locknut (03C) onto the shaft until tight. Align one of the slots in the locknut with one of the tabs on the lockwasher, and use a hammer and punch to bend the tab on the lockwasher over into the slot on the locknut.

Proceed with **Setting End Clearance**.

SETTING END CLEARANCE

(Figures E-1 and E-6)

The end clearance between the head (01A) and the face of the rotor (03A) should be checked and adjusted as required as part of a regular preventive maintenance schedule, when performance drops or the pump is disassembled.

See Figure E-6 and mark the rotor adjusting sleeve (07AA) at the beveled mark on the backhead (06A).

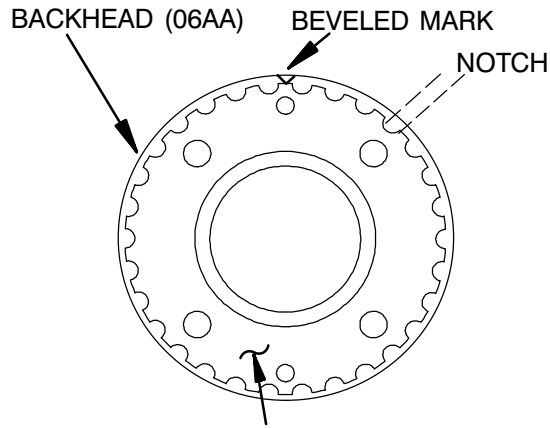

ROTOR ADJUSTING SLEEVE (07AA)
Figure E-6. End Clearance Adjustment

The proper end clearance for your pump can be determined by Table E-2 which shows correct end clearance based on the rotor trim code indicated on the pump Parts List. Determine the end clearance for your pump from the table, then proceed as follows.

Each of the notches on the rotor adjusting sleeve (07AA) represents approximately 0.002 inch of end clearance. Back off the rotor adjusting sleeve approximately 1/2 turn, then turn the sleeve back in until the mark is the appropriate number of notches counterclockwise of the beveled mark on the backhead to obtain the recommended end clearance.

Tighten the setscrews (GA) until they bottom against the backhead (06A). Rotate the pump shaft to ensure free rotation. If the rotor binds or scrapes against the head, back off the rotor adjusting sleeve until rotation is free.

Table E-2. End Clearance Based on Hydraulic Size, Viscosity and Temperature

	Rotor Trim Code	Pump Hydraulic Code				
		D	G	J	N	R
V i s c o s i t y T r i m s	Std	.005	004	.006	.008	.010
	35C		006	.008	.008	.010
	35D	.009	009	.012	.012	.014
T e m p T r i m s	35J	.006	.006	.008	.010	.010
	35L		008	.010	.012	.014
	35M		010	.012	.014	.016

Notes:
 Consult Pump Parts List For Rotor Trim Code.
 For Rotor Trim Codes Not Listed or for Special Applications,
 Consult Your Local Gorman-Rupp Distributor or the Factory.

Table E-3. End Clearance Based on Rotor Trim Code

RELIEF VALVE DISASSEMBLY

(Figure E-7)

NOTE

If the relief valve is low pressure, it will have one internal spring (10AE). If the relief valve is high pressure, it will have two internal springs (10AE and 10AF).

Unscrew the cap (10AN) from the bonnet (10AK).

Remove the optional gasket (10AP, if so equipped). Back off the adjustment capscrew (10AM) to relieve pressure on the spring(s) (10AE and/or 10AF).

Unscrew the bonnet from the valve body (10AA) and remove the gasket (10AJ) or O-ring (10C). Remove the valve (10AD) and spring(s) (10AE and/or 10AF). The spring guide (10AH) is an O-ring fit in the bonnet. Remove and discard the O-rings.

If the warning plate (10AB) must be replaced, remove the drive screws (BM), and remove the plate.

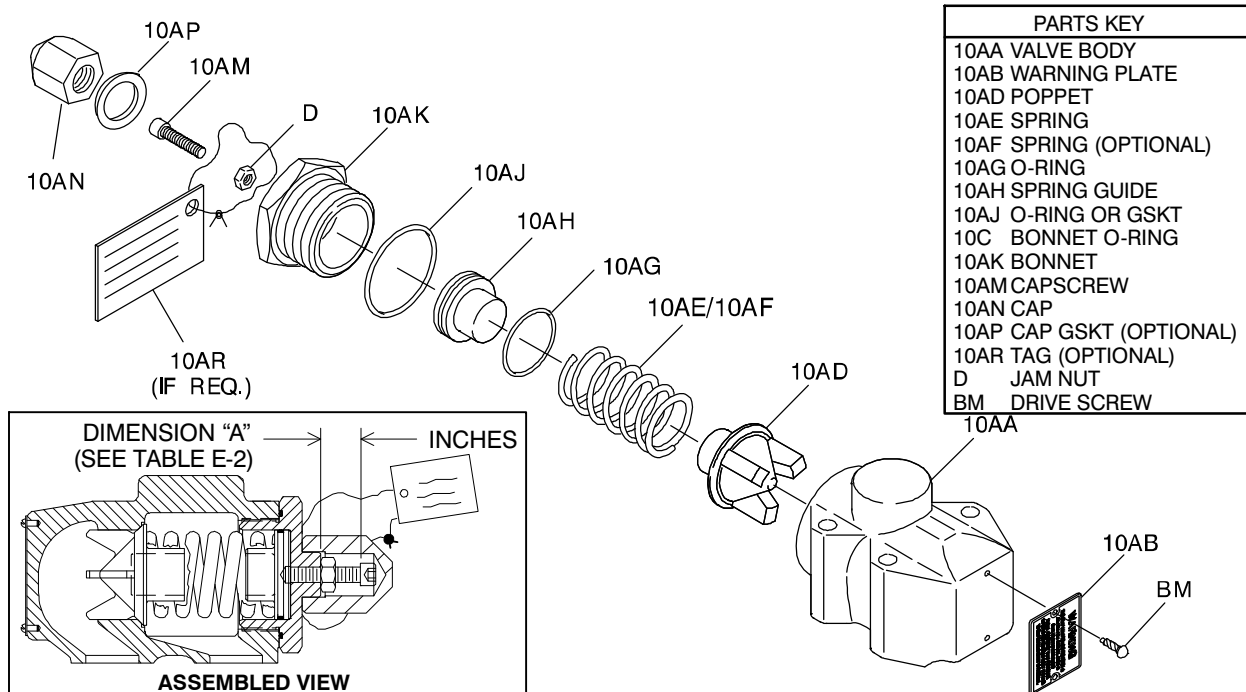

Figure E-7. Pressure Relief Valve Assembly

RELIEF VALVE REASSEMBLY

(Figure E-7)



Do not return the pump to service without the warning plate (10AB) installed. Failure to observe the warning on the plate could result in destruction of the pump, and injury or death to personnel.

Inspect the components for wear, grooves, or other damage that might cause leakage. If any components are worn, replace the defective parts.

If removed, attach the warning plate (10AB) to the valve body (10AA) using the drive screws (BM).

If used, lightly oil the O-ring or gasket (10AJ) and install it in the groove on the bonnet (10AK).

Lightly oil the O-ring (10AG) and install it in the groove on the spring guide (10AH). Start the large end of the spring guide into the bonnet (10AK), and push the guide in until it bottoms out.

Insert the valve (10AD), finned end first, into the valve body (10AA). Install the spring(s) (10AE and/or 10AF). Make certain that the spring (10AE) fits **over** the spring guide (10AH), and the optional spring (10AF) fits **into** the guide, and thread the bonnet into the valve body.

Install the jam nut (D) on the adjustment capscrew (10AM), and thread the capscrew into the bonnet until the desired height ("A", Figure E-7) is reached. Refer to the separate Parts List accompanying your pump, and determine the specific hydraulic size. See Table E-4 and adjust the capscrew (10AM) to the proper "A" dimension for desired cracking pressure.



Never operate the pump without the adjusting screw jam nut in place. Otherwise, the relief valve spring(s) can be compressed too far for the valve to open. If the valve does not open, excessive pressure can develop, causing damage to the pump and possible injury to personnel.

PUMP HYDRAULIC SIZE	SINGLE SPRING OPTION CODE	CRACKING PRESSURE (PSI)	DIMENSION "A" (INCHES) (1)	DOUBLE SPRING OPTION CODE	CRACKING PRESSURE (PSI)	DIMENSION "A" (INCHES) (1)
D & G	STD			25A	60 MIN.	.60 FULLY OUT
		45 MIN.	.60 FULLY OUT			
	25D	50	.57	25E	88	.51
		* 75	.40		* 113	.42
	25G	100	.22	25H	125	.34
		130 MAX.	.16 FULLY IN		150	.26
25U			25V	170 MAX.	.16 FULLY IN	
J & N	STD			25A	35 MIN.	1.17 FULLY OUT
		30 MIN.	1.17 FULLY OUT			
	25D	50	.74	25E	100	.68
		* 70 MAX.	.31 FULLY IN		125	.51
	25G			25H	* 150 MAX.	.31 FULLY IN
25U						
R	STD			25A	40 MIN.	1.23 FULLY OUT
		40 MIN.	1.23 FULLY OUT			
	25D	* 75	.71	25E	100	.93
		90 MAX.	.37 FULLY IN		125	.74
	25G			25H	* 150	.51
25U			25V	170 MAX.	.37 FULLY IN	

Table E-4 . Cracking (Valve Opening) Settings (* Denotes Factory Setting)

After adjustment, tighten the jam nut (D) flush against the bonnet.

bonnet and the cap (10AN). Install the cap, and tighten until fully seated against the bonnet.

Place the optional warning tag (10AR) between the

Relief Valve (10) Installation

Lubricate and install the O-ring(s) or gaskets (10C) on the housing assembly (04A) or the head assembly (01A). Secure the relief valve (10A) with the capscrews (B).



Do not return the pump to service without the warning plate (10AB) installed. Failure to observe the warning on the plate could result in destruction of the pump, and injury or death to personnel.

If the warning plate (10AB) has been removed, secure it with the drive screws (BM).

SEAL APPENDIX - SECTION F

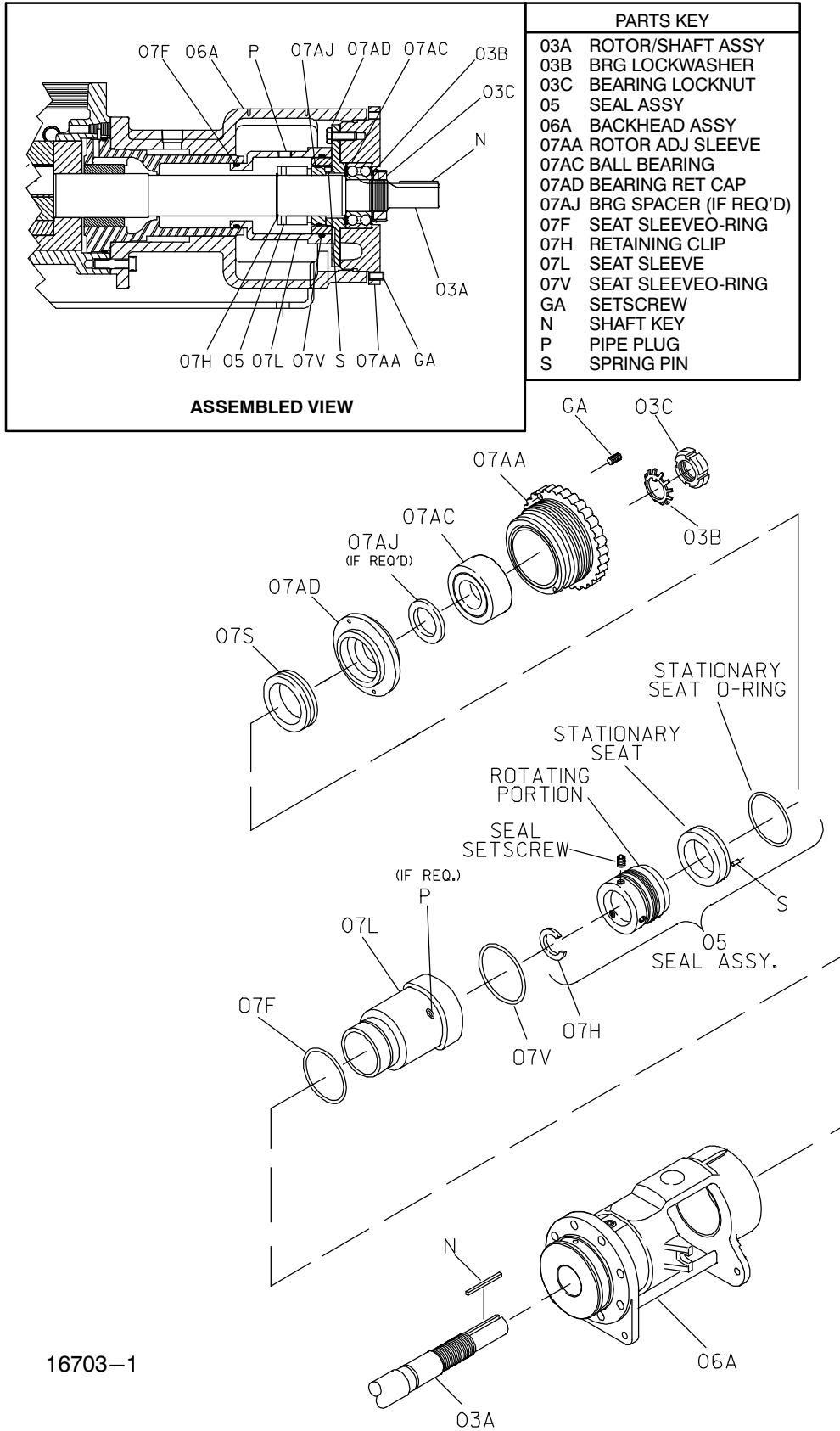

16703-1

Figure F-1. Standard 60 Seal Assembly

Seal Removal

(Figures E-1 and F-1)

See **PUMP DISASSEMBLY** and disassemble the pump up to and including the **Rotor Adjusting Sleeve (07)**. As the rotor adjusting sleeve (07AA) is unscrewed from the backhead (06A), the seal stationary element will remain inside the intermediate seat sleeve (07S). The seat sleeve is a light press fit over the shoulder of the seat sleeve (07L). It is not necessary to remove the intermediate seat sleeve from the seat sleeve shoulder.

Remove the seal stationary element and O-ring from the intermediate seat sleeve. **Use caution** not to damage the stationary element sealing face.

Remove the seat sleeve O-ring (07V) from the groove in the I.D. of the seat sleeve.

Reach through the opening in the backhead and remove one of the pipe plugs (P) from tapped hole in the seat sleeve. Rotate the shaft until the setscrew(s) in the rotating portion of the seal (05) align with the pipe plug hole in the seat sleeve and use an allen wrench to loosen the seal setscrews.

Slide the rotating portion of the seal off the shaft.

Seal Installation

(Figures E-1 and F-1)

See **Pump Reassembly, Section E**, and assemble the housing assembly (04), backhead kit (06) and rotor/shaft assembly (03).

Clean the seal cavity and shaft with a cloth soaked in fresh cleaning solvent.



Most cleaning solvents are toxic and flammable. Use them only in a well ventilated area free from flame, sparks, and excessive heat. Read and follow all precautions printed on solvent containers.

The seal is not normally reused because wear patterns on the finished faces cannot be realigned during reassembly. This could result in premature failure. If necessary to reuse an old seal in an emer-

gency, **carefully** wash all metallic parts in fresh cleaning solvent and allow to dry thoroughly.

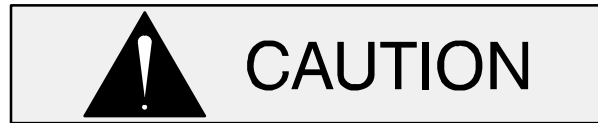

Seal components **must** be kept clean. Handle seal parts with extreme caution to prevent damage. Use care not to contaminate the precision-finished faces; even fingerprints on the faces can shorten seal life. If necessary to clean the faces, use a clean cloth and wipe in a circular pattern.

Inspect the seal components for wear, scoring, grooves, and other damage that might cause leakage. If any components are worn, replace the complete seal; **never mix old and new seal parts**.

If a replacement seal is being used, unwrap the cartridge seal components. Check that the seal faces are clean, undamaged and free of any foreign matter.

Position the pump on a flat surface with the drive end facing up. Lightly oil the shaft of the rotor/shaft assembly (03A).

Lightly lubricate the seat sleeve O-ring (07V) and install it in the groove in the I.D. of the seat sleeve (07L).

Push the rotating portion of the seal onto the lubricated shaft until fully seated against the retaining clip (07H).

Assemble the rotor adjusting sleeve (07) as described in **Pump Reassembly, Section E** and position it on a flat surface with the drive end down.

Lubricate the stationary seat O-ring with light oil. Place a clean tissue over the seal face of the seal stationary element. Align the spring pins (S) in the stationary element with the holes in the bearing retaining cap (07AD) and press the element into the bore of the intermediate seat sleeve (07L) until the pins are fully seated in the bearing retaining cap.

Remove the tissue and proceed with **Pump Reassembly, Section E**.

After setting the end clearance, tighten the seal setscrews and reinstall the pipe plug (P) in the seat sleeve.

SEAL APPENDIX - SECTION F

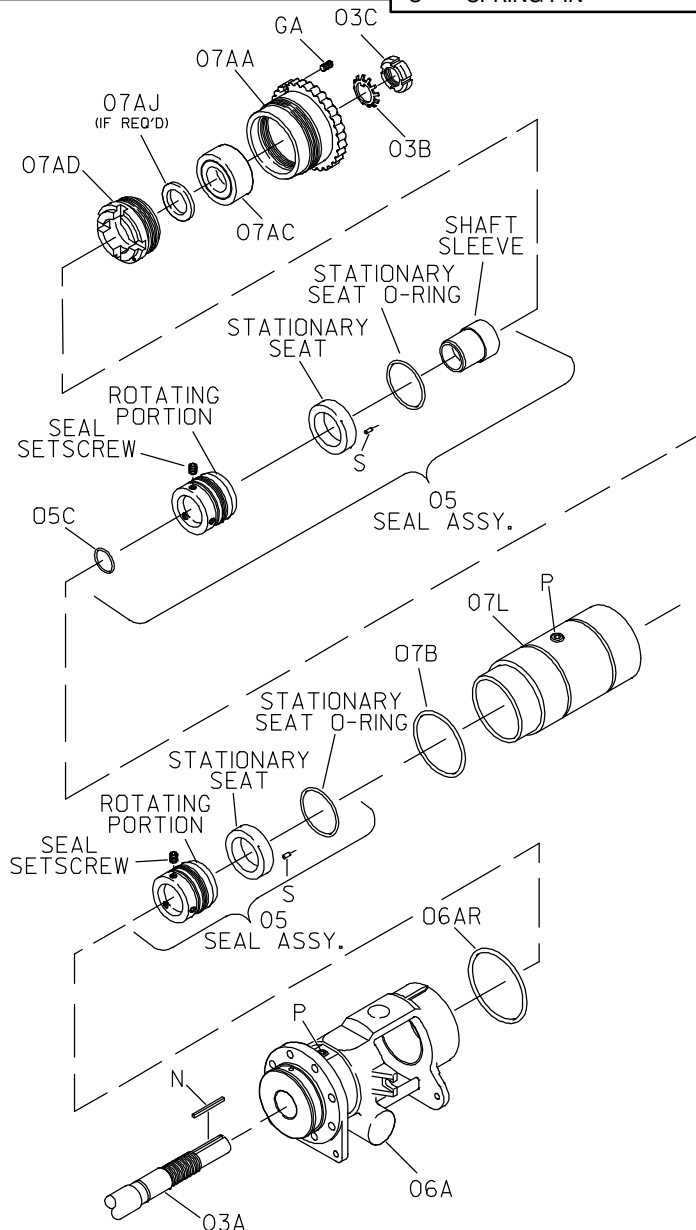
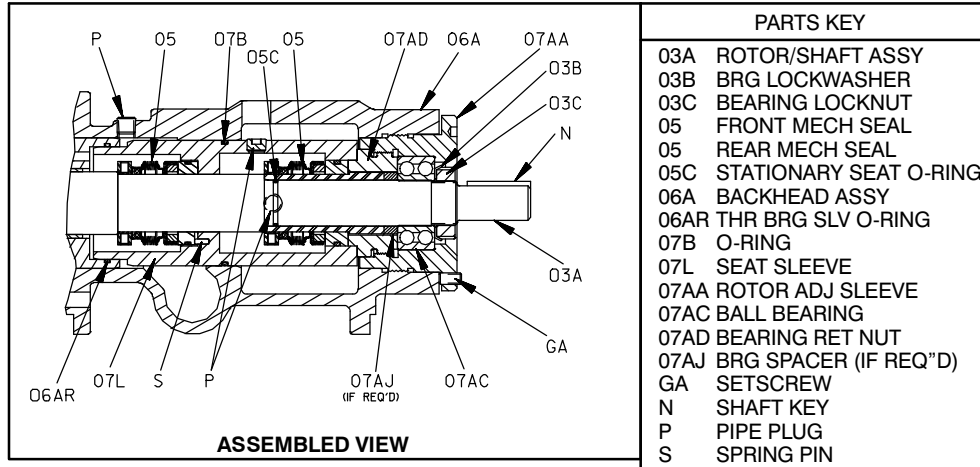

16703-2

Figure F-2. Positive Locking Tandem Mechanical Seal (Option 60S)

Seal Removal

(Figures E-1 and F-2)

See **PUMP DISASSEMBLY** and disassemble the pump up to and including the **Rotor Adjusting Sleeve (07)**.

Reach into the backhead (06A) and slide the rear seal (05) off the shaft as an assembly.

If necessary, reach through the windows in the backhead with suitable prying devices and work the seat sleeve (07L) out of the backhead.

Remove the shaft O-ring (05C).

Remove the front seal stationary element and O-ring from the seat sleeve. **Use caution** not to damage the stationary element sealing face. Remove the O-ring (05C) from the O.D. of the seat sleeve.

Remove the foremost pipe plug (P). Use an allen wrench to loosen the setscrews in the collar of the front seal (05).

Slide the rotor/shaft back into the housing until the front seal is pushed toward the rear of the shaft. Pull the shaft toward the drive end of the housing until the front seal can be grasped and pulled off the shaft.

NOTE

Due to the complexity of design of the seal assemblies, seal disassembly for the purpose of reuse is not recommended. Replace the complete seal(s) when leakage occurs.

Continue as required with **PUMP DISASSEMBLY**.

Seal Installation

(Figures E-1 and F-2)

See **PUMP REASSEMBLY**, and assemble the housing assembly (04), backhead kit (06) and rotor/shaft assembly (03).

Clean the seal cavity and shaft with a cloth soaked in fresh cleaning solvent.



Most cleaning solvents are toxic and flammable. Use them only in a well ventilated area free from flame, sparks, and excessive heat. Read and follow all precautions printed on solvent containers.

Inspect the seal components for wear, scoring, grooves, and other damage that might cause leakage. If any components are worn, replace the complete seal; **never mix old and new seal parts**.

If replacement seals are being used, unwrap the seals and check that all components are preassembled, clean, undamaged and free of any foreign matter.

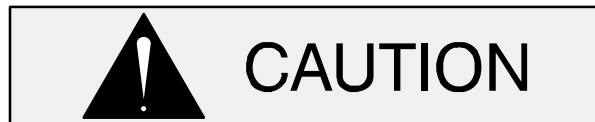

Seal components **must** be kept clean. Handle seal parts with extreme caution to prevent damage. Use care not to contaminate the precision-finished faces; even fingerprints on the faces can shorten seal life. If necessary to clean the faces, use a clean cloth and wipe in a circular pattern.

Position the pump on a flat surface with the drive end facing up. Lightly oil the shaft of the rotor/shaft assembly (03A) and install the O-ring (05C) in the groove in the shaft. Lightly lubricate the O-ring (06AR) in the back of the throttle bushing sleeve (06AD).

Slide the rotating portion of the front seal assembly onto the shaft until the collar is fully seated against the shaft shoulder. Reach through the hole for the foremost pipe plug (P) with an allen wrench and secure the seal collar to the shaft by tightening the collar setscrews.

Lubricate and install the O-ring (07B) in the groove in the O.D. of the seat sleeve (07L). Position the stationary element in the seat sleeve with the sealing face up. Cover the sealing face with a clean tissue and use thumb pressure to press the stationary element into the seat sleeve until fully seated.

Align the foremost pipe plug opening in the seat sleeve with the hole in the backhead and slide the

seat sleeve onto the shaft until the stationary element seats against the rotating element.

Slide the rear cartridge seal assembly into the rotor adjusting sleeve assembly until fully seated. Press the seat sleeve onto the rotor adjusting sleeve assembly (07AA) until fully seated.

Assemble the rotor adjusting sleeve (07) and seal unit, and proceed with **Pump Reassembly, Section E**.

Optional Reservoir Kit

An optional Reservoir Kit is available from the factory for applications requiring a barrier liquid to lubricate and protect the seal from the liquid being pumped.

Install the Reservoir Kit as shown in Figure F-2A and select a suitable barrier liquid according to the criteria shown in **Installation, Section B**. Fill the reservoir through the hole for the top fill plug (13AB) to the middle of the sight gauge (13AC) and maintain the liquid at this level.

Do not pressurize the reservoir. Pressurizing a tandem seal will cause the seal faces to separate, resulting in leakage and/or damage to the seal. The barrier liquid should be supplied at atmospheric pressure **only**.

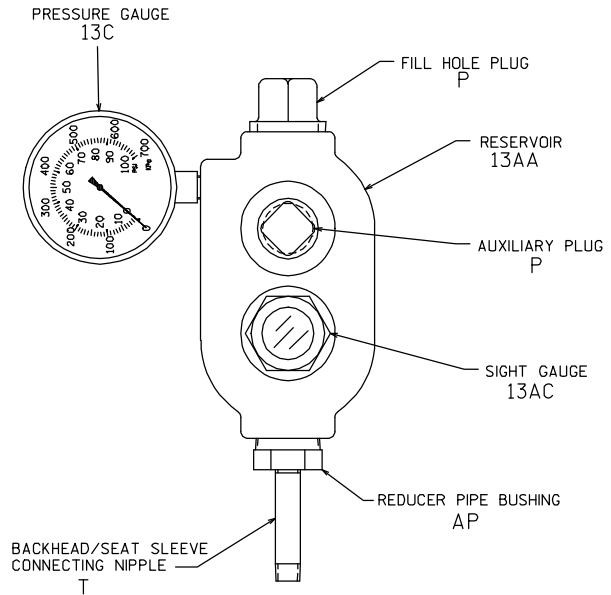
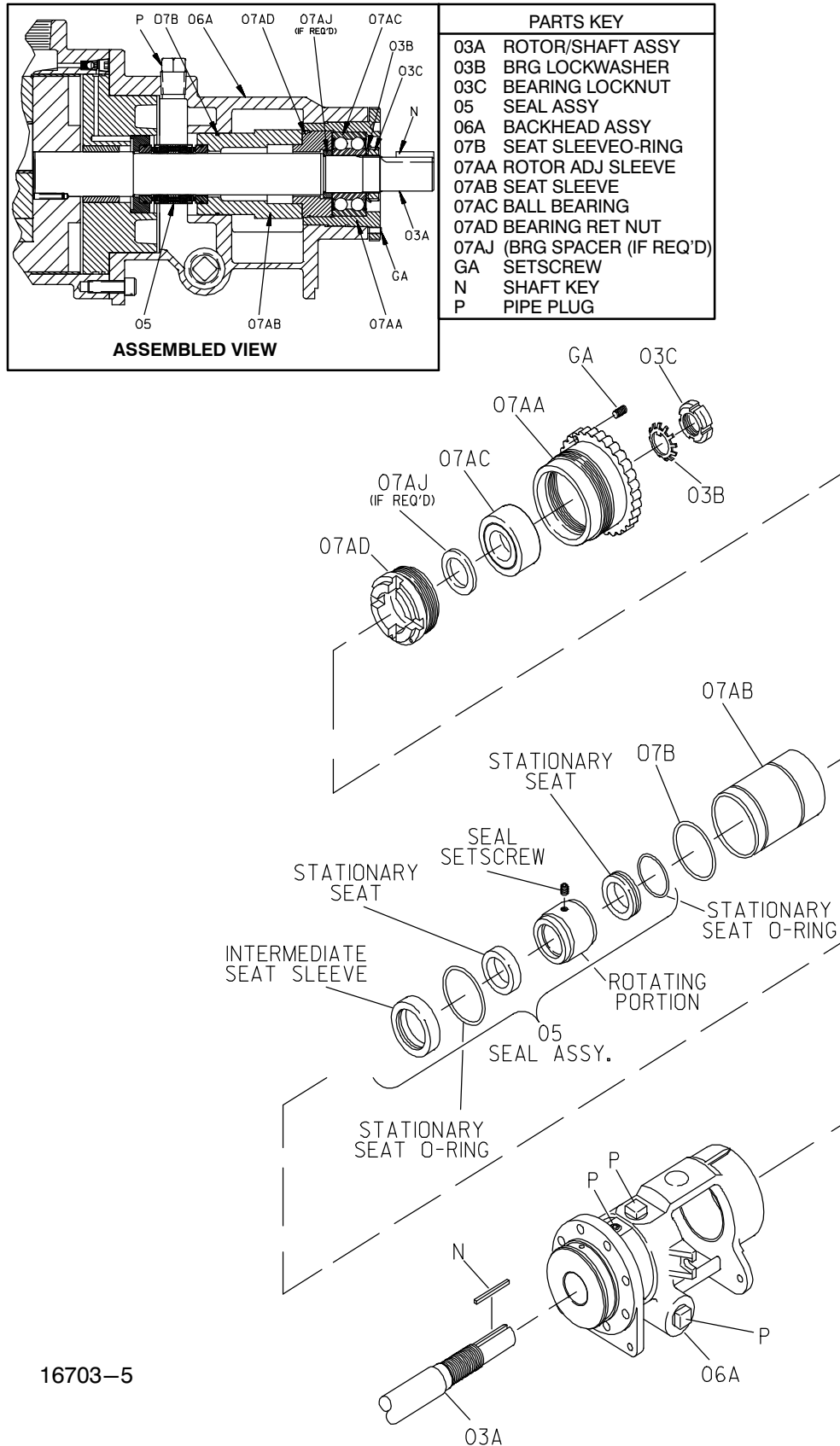

Figure F-2A. Reservoir Kit

SEAL APPENDIX - SECTION F



16703-5

Figure F-3. Double Positive Drive (Option 60J) Seal

Seal Removal

(Figures E-1 and F-3)

See **PUMP DISASSEMBLY** and disassemble the pump up to and including the **Rotor Adjusting Sleeve (07)**. As the rotor adjusting sleeve (07AA) is unscrewed from the backhead (06AA), the seal stationary element will remain inside the seat sleeve (07AB).

Remove the seal stationary element and O-ring from the seat sleeve. **Use caution** not to damage the stationary element sealing face.

Use a screwdriver to pry the seat sleeve (07AB) off the O.D. of the bearing retaining nut (07AD). Remove the seat sleeve O-ring (07B).

Remove the pipe plug (P) at the top of the backhead and loosen the setscrews on the rotating head. With the head kit (01), idler assembly (02) and rotor adjusting sleeve (07) removed, push the rotor/shaft assembly (03A) toward the head end of the pump until the seal between the shaft and rubber bellows of the inboard and outboard rotating portion of the seal breaks loose. Slide the rotor/shaft back into the housing until the rotating portions of the seal can be grasped. Hold the seal while sliding the rotor/shaft assembly toward the head end of the pump until the seal slides completely off the shaft.

Slide the rotor/shaft assembly out of the housing. Position the pump on a flat surface with the head end up and use a dowel to press the inboard stationary seat out of the inboard element seat sleeve (06AK).

The inboard element seat sleeve is a tight press fit into the throttle bushing sleeve (06AD). If replacement is required, press the sleeve out after disassembling the backhead (see **PUMP DISASSEMBLY**).

Seal Installation

(Figures E-1 and F-3)

See **Pump Reassembly, Section E**, and assemble the housing assembly (04), backhead kit (06) and rotor/shaft assembly (03).

NOTE

If the inboard element seat sleeve (06AK) was re-

moved, use an arbor (or hydraulic) press to install the replacement sleeve in the throttle bushing sleeve until fully seated.

Clean the seal cavity and shaft with a cloth soaked in fresh cleaning solvent.



Most cleaning solvents are toxic and flammable. Use them only in a well ventilated area free from flame, sparks, and excessive heat. Read and follow all precautions printed on solvent containers.

The seal is not normally reused because wear patterns on the finished faces cannot be realigned during reassembly. This could result in premature failure. If necessary to reuse an old seal in an emergency, **carefully** wash all metallic parts in fresh cleaning solvent and allow to dry thoroughly.



Seal components **must** be kept clean. Handle seal parts with extreme caution to prevent damage. Use care not to contaminate the precision-finished faces; even fingerprints on the faces can shorten seal life. If necessary to clean the faces, use a clean cloth and wipe in a circular pattern.

Inspect the seal components for wear, scoring, grooves, and other damage that might cause leakage. If any components are worn, replace the complete seal; **never mix old and new seal parts.**

If a replacement seal is being used, unwrap the mechanical seal components. Check that the seal faces are clean, undamaged and free of any foreign matter. Set aside and cover the outboard seal stationary element and O-ring; it will not be used until the rotor adjusting sleeve kit (07) is installed.

Place a clean tissue over the seal face of the inboard seal stationary element, and press the element into the bore of the inboard stationary element seat sleeve (06AK) until fully seated.

Position the pump on a flat surface with the drive end facing up. Lightly oil the shaft of the rotor/shaft assembly (03A).

Push this rotating subassembly onto the shaft until the seal faces contact.

Assemble the rotor adjusting sleeve (07) as described in **Pump Reassembly, Section E** and position it on a flat surface with the drive end down.

Oil the O-ring (07C) and install it in the groove in the seat sleeve (07AB). Position the sleeve over the shoulder on the bearing retaining nut (07AD) and press the sleeve onto the nut until fully seated.

Lubricate the stationary element O-ring and position the stationary element in the seat sleeve with the sealing face up. Cover the sealing face with a clean tissue and use thumb pressure to press the stationary element into the seat sleeve until fully seated. Remove the tissue and proceed with **Pump Reassembly, Section E**.

After setting the end clearance, tighten the seal setscrews and reinstall the pipe plug (P).

Optional Reservoir Kit

An optional pressurized Reservoir Kit is available from the factory for applications requiring a barrier liquid to lubricate and protect the seal from the liquid being pumped.

Install the Reservoir Kit as shown in Figure F-3A and connect the pressurizing source at the male connector (13E). Select a suitable barrier liquid according to the criteria shown in **Installation, Section B**.

NOTE

The pressurizing source liquid must be incapable of mixing with the barrier liquid and must be of a lesser specific gravity.

Fill the reservoir through the top fill plug hole (13AB) to the level of the shutoff valve (13AD). Open the shutoff valve and energize the pressurizing source. The source pressure **must** be equivalent to the maximum discharge pressure.

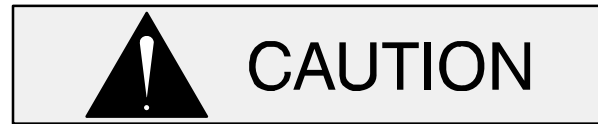

Close the shutoff valve and allow the pressure in the reservoir to bleed off before opening the fill port plug (13AB).

The barrier liquid will gradually be consumed as the pump runs. Refill the reservoir when the barrier liquid reaches the middle of the sight gauge (13AC).

When the pump is shut down, isolate the reservoir from the pressurizing liquid by closing the shutoff valve (13AD) or isolating the liquid at its source.

NOTE

The reservoir must be pressurized to equal the maximum discharge pressure of the pump.

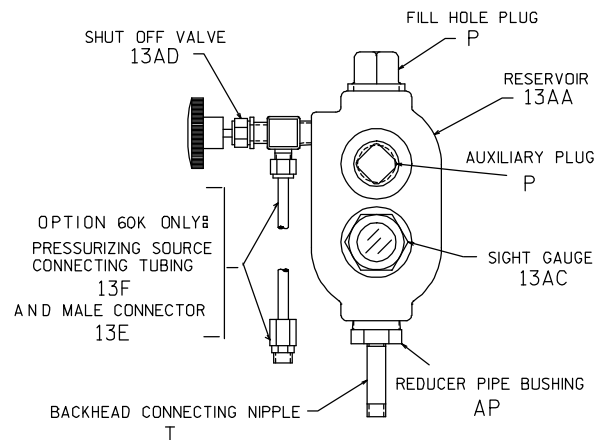
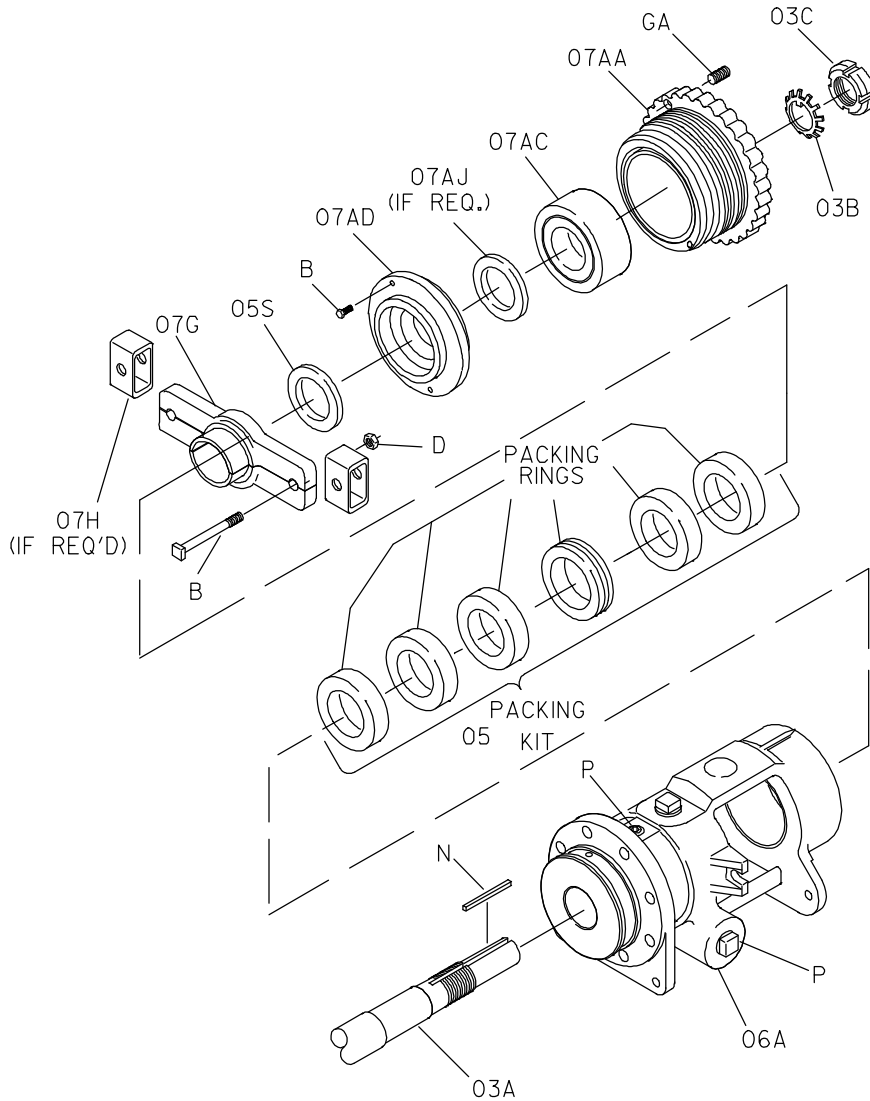
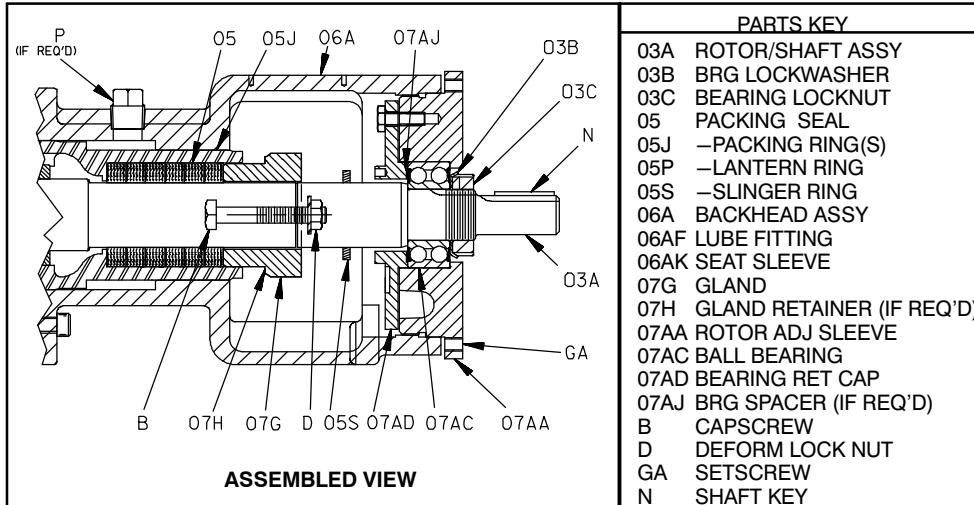

Figure F-3A. Reservoir Kit

SEAL APPENDIX - SECTION F



16703-6

Figure F-4. Optional Packing Seal

Packing Seal Removal

(Figures E-1 and F-4)

If the pump is equipped with a split packing gland (07G) the pump does not need to be disassembled to remove the packing seal.

Loosen the gland locknut (D) and remove the gland retainers (07H, if required) and split gland halves (07G).

If the pump is equipped with a one-piece packing gland (07G), see **PUMP DISASSEMBLY** and disassemble the pump up to and including the **Rotor Adjusting Sleeve (07)**.

Use a stiff wire with a hooked end to remove the packing rings and lantern ring from the backhead sleeve (06AD). Make sure all of the old packing is removed before installing the new packing.

Packing Seal Installation

(Figures E-1 and F-4)

Clean the seal cavity and shaft with a cloth soaked in fresh cleaning solvent.



Most cleaning solvents are toxic and flammable. Use them only in a well ventilated area free from flame, sparks, and excessive heat. Read and follow all precautions printed on solvent containers.

NOTE

It is recommended that replacement packing rings pre-cut to the correct width and length and packaged in sets (see the separate Parts List accompanying your pump) be ordered from your Gorman-Rupp distributor or the factory. However, if bulk commercial packing will be used, prepare and install it in accordance with the steps outlined below in order to ensure that the packing will form a tight seal.

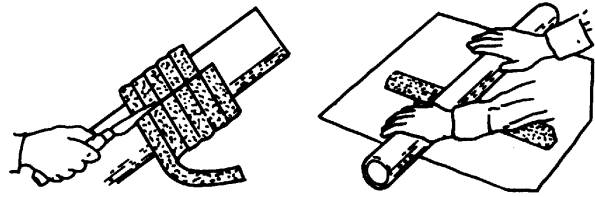

Figure F-4A.

Step 1: Determine how much bulk packing will be required to fill the seal cavity and wrap it around a rod the same diameter as the shaft. With the packing wrapped around the rod, cut through each turn as shown in Figure F-4A.

If the cut rings are too thick and will not fit in the packing cavity, place each turn on a clean piece of paper and use a length of pipe to roll the ring until the thickness has been reduced. **Never** attempt to flatten a packing ring with a hammer.



Figure F-4B.

Step 2: It is critical that the ends of the cut packing ring meet in a tight parallel fit to ensure proper sealing. Check this fit; it should be correct if the packing was cut while wrapped around a rod, but if the packing was cut while laid out straight the ends will meet at an angle. **Never** install packing rings with an angled gap; pressure on adjacent packing rings will cause them to work into the gap and prevent the angled ring from closing properly around the shaft.

Some channel-type packing with a lead core may require a slight gap between packing rings to allow for expansion. Consult the packing manufacturer's installation instructions and follow the recommendations.

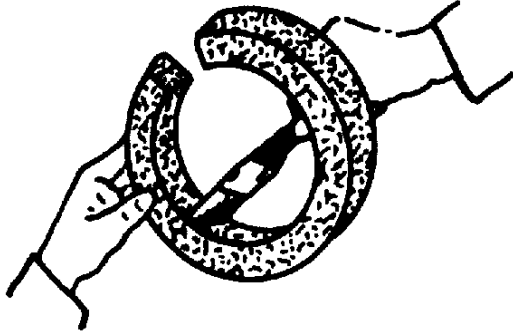

Figure F-4C.

Step 3: Lubricate all metallic packings (foil type, lead core, etc.) with the lubricant recommended by the manufacturer. Generally swabbing the I.D. of the packing with SAE No. 30 non-detergent oil provides sufficient lubrication.

Lubricate the new packing rings with non-detergent oil before installation. For best performance, do not stretch or separate packing braids. Install the gasket (if required) first, then install the yellow packing ring as shown in Figure F-4D. Next, push each black packing ring into the seal bore and compress it using a blunt ended sleeve (split in half, same diameter as the split glands) and mallet. Each successive layer must be compressed and rotated by 90° to prevent excessive leakage. **Be sure** the lantern ring is aligned with the lubrication port when the packing is fully compressed. Add enough packing to fill the seat sleeve to within 3/8-inch of the end.

If the pump is equipped with a split packing gland (07G), position the split gland halves on the shaft and install the gland retainers (07H) over the ends of the split gland. If the pump is equipped with a one-piece packing gland, simply slide the gland over the shaft.

Install the hardware (B and D) and tighten in an alternating pattern until the packing gland begins to compress the packing.



Do not overtighten the gland nuts. If the packing rings are compressed too tightly, they may cause the shaft to overheat and damage the pump.

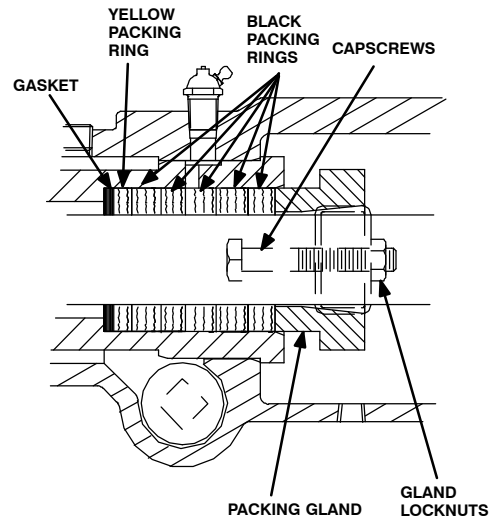
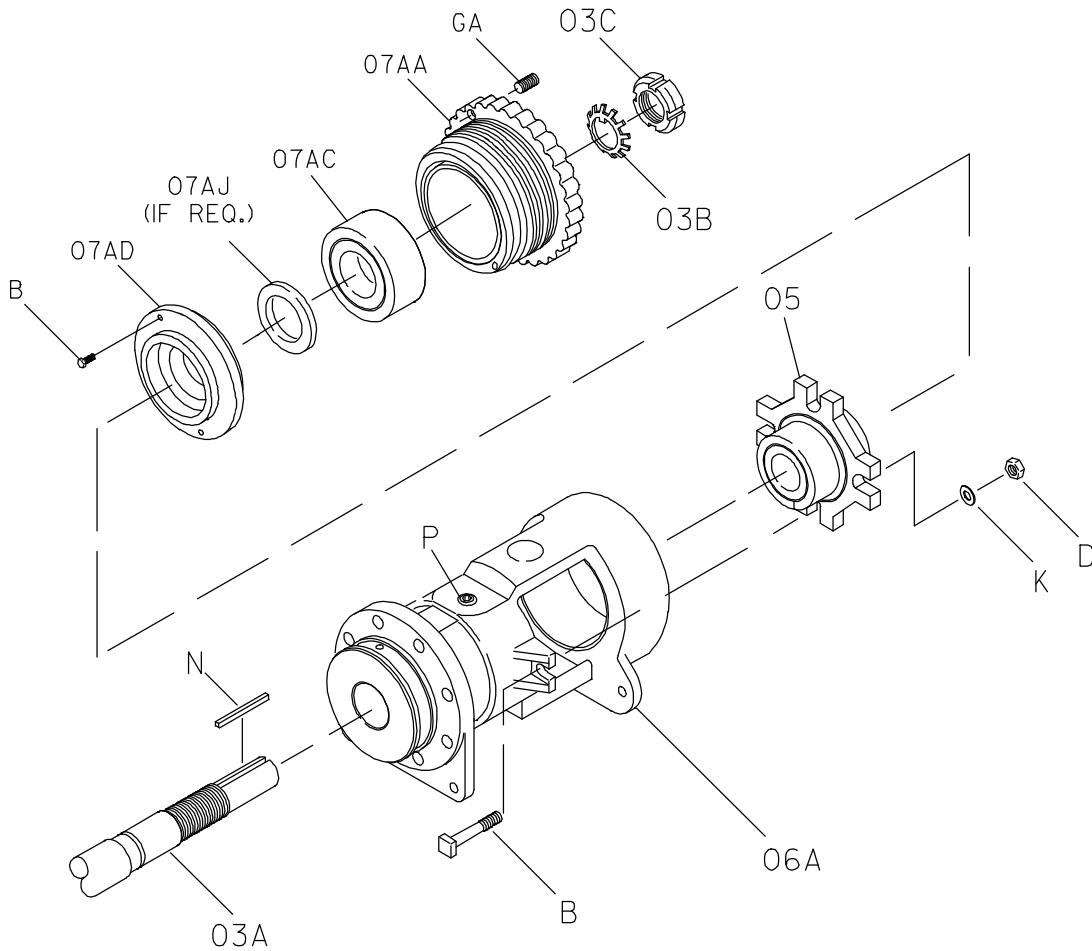
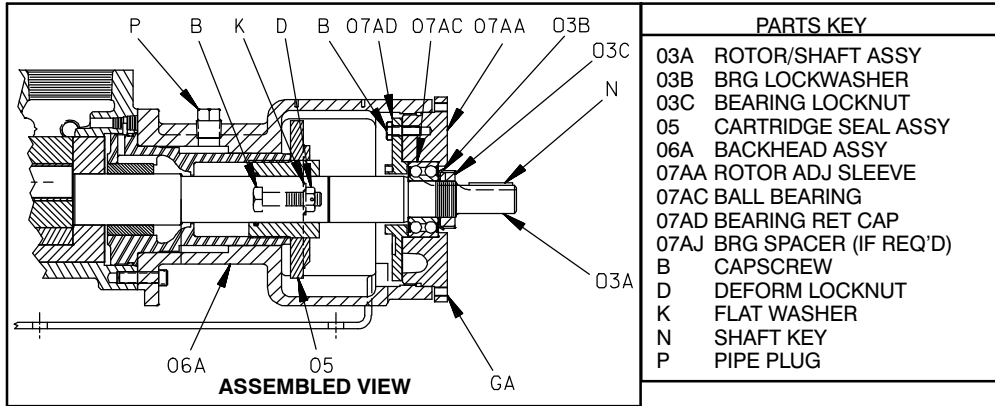

Figure F-4D. Typical Minimum Leak Packing Seal Installation

If the pump is equipped with a one-piece packing gland (07G), assemble the rotor adjusting sleeve (07) and proceed with **Pump Reassembly, Section E.**

SEAL APPENDIX - SECTION F



16703-8

Figure F-5. Cartridge Seal

Seal Removal

(Figures E-1 and F-5)

See **PUMP DISASSEMBLY** and remove the **Rotor Adjusting Sleeve (07)**.

Remove the hardware (B, D and K) securing the cartridge seal assembly (05) to the backhead (06A). Loosen the allen head setscrews securing the rotating portion of the seal to the shaft.

Reach through the opening in the backhead pull the cartridge seal off the shaft.

Seal Installation

(Figures E-1 and F-5)

See **Pump Reassembly, Section E**, and assemble the housing assembly (04), backhead kit (06) and rotor/shaft assembly (03).

Clean the seal cavity and shaft with a cloth soaked in fresh cleaning solvent.



Most cleaning solvents are toxic and flammable. Use them only in a well ventilated area free from flame, sparks, and excessive heat. Read and follow all precautions printed on solvent containers.

In many cases it may not be necessary to replace the entire cartridge seal assembly when the seal fails. Seal re-build kits are available from the seal manufacturers; consult the factory.

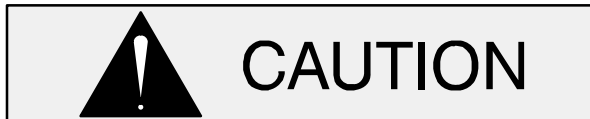

Seal components **must** be kept clean. Handle seal parts with extreme caution to prevent damage. Use care not to contaminate the precision-finished faces; even fingerprints on the faces can shorten seal life. If necessary to clean the faces, use a clean cloth and wipe in a circular pattern.

Inspect the seal components for wear, scoring, grooves, and other damage that might cause leakage.

If a replacement seal is being used, unwrap the mechanical seal components.

Lightly lubricate the seal area of the shaft using a soft hand soap and water solution, glycerine or silicone grease. **Do not use petroleum based lubricants.**

Slide the cartridge seal assembly onto the shaft until the seal gland plate is fully seated against the backhead. A pusher tube may be used to evenly force the seal into position. Rotate the seal until the seal ports are in a suitable position for equipment piping.

Assemble the rotor adjusting sleeve (07) and adjust the end clearance as described in **Pump Reassembly, Section E**. The end clearance must be set before completing the seal installation.

Install the hardware (B, D and K) and lightly snug the gland to the face of the seal chamber. Tighten the gland nuts evenly in a cross pattern, two flats at a time, to the torque values shown in Table E-1 for the size of the gland hardware.

NOTE

*The gland hardware must be tightened equally to prevent seal misalignment **before tightening the seal setscrews.***

Due to variations in seal design from the manufacturers, some seals may be equipped with centering/alignment clips and others may not. If the seal has centering/alignment clips, turn the clips 90° to the shaft and check to ensure absolute centering on the drive collar (consult the literature provided with the seal for additional instructions).

Turn each of the seal setscrews until the tip of each setscrew just touches the shaft. After the setscrews all touch the shaft, tighten the setscrews until the points of the setscrews are embedded in the shaft. This should keep the seal centered on the shaft. Follow setscrew torque values as described in the literature provided with the seal.

If so equipped, ensure that the centering/alignment clips are positioned 90° to the shaft. Rotate the shaft by hand to ensure that the drive collar is not rubbing or binding against any of the clips.

If adjustment is required, loosen the gland nuts and move the gland slightly to achieve centering,

then re-tighten the gland nuts. Repeat the process as required to ensure seal/shaft concentricity.

After the seal is properly centered on the shaft, ro-

tate the seal centering clips (if so equipped) 90°.

Install seal piping as required, or ensure that seal ports are plugged.

SEAL APPENDIX - SECTION F

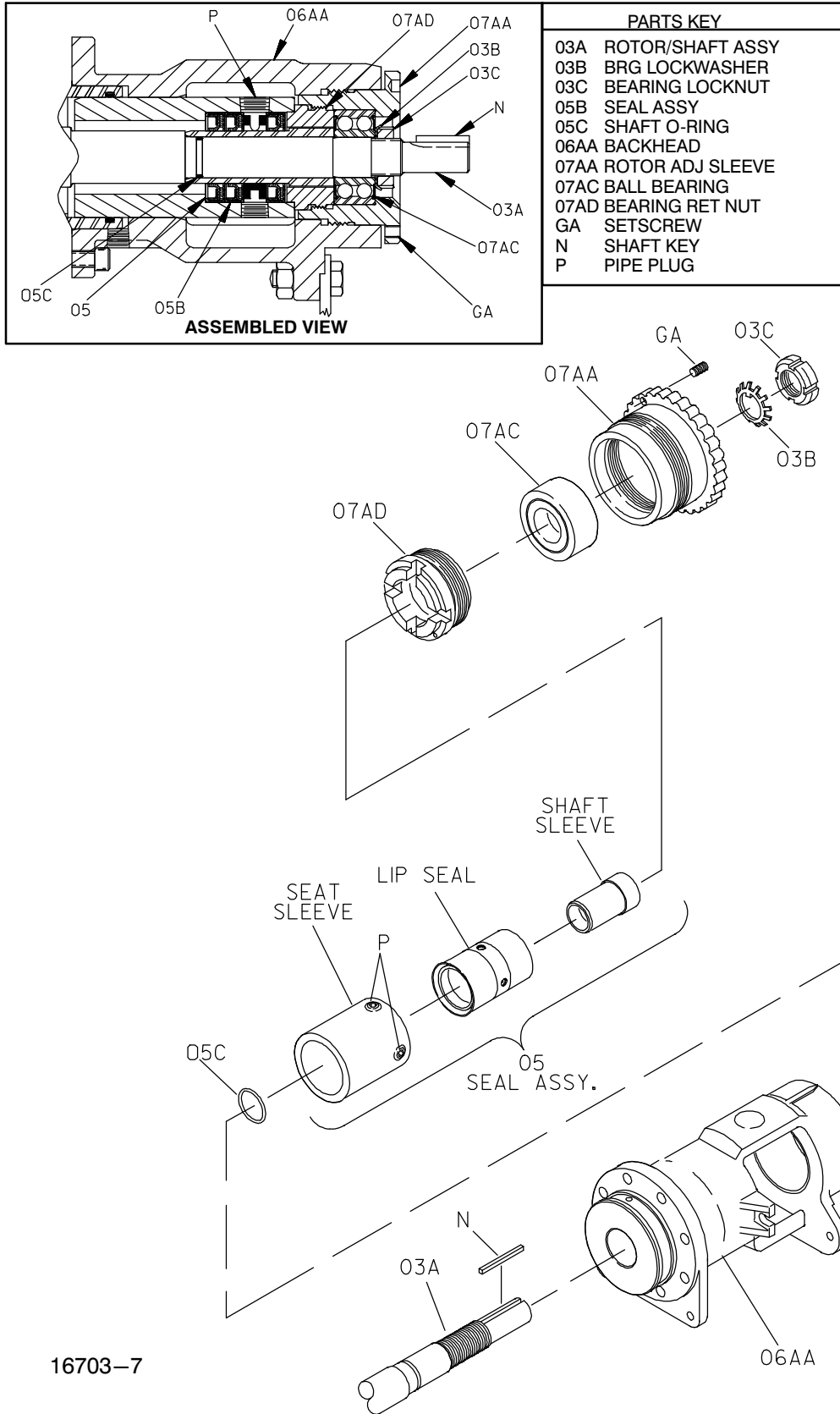

16703-7

Figure F-6. Option 65E Cartridge Lip Seal ("D" Size Only)

Seal Removal

(Figures E-1 and F-6)

See **PUMP DISASSEMBLY** and disassemble the pump up to and including the **Rotor Adjusting Sleeve (07)**.

Reach through the “window” in the backhead (06AA) and slide the cartridge lip seal assembly (05) off the shaft.

Remove the shaft O-ring (05C).

The cartridge seal is replaceable as an assembly. To replace the seal, loosen the setscrews securing the seal to the shaft sleeve and pull the sleeve out of the seal assembly.

Removal of the seat sleeve (06AK) is not normally required. If replacement is desired, continue with **PUMP DISASSEMBLY**, then use an arbor (or hydraulic) press and a suitably sized dowel to press the seat sleeve out of the backhead from the front end of the backhead.

Seal Installation

(Figures E-1 and F-6)

If the seat sleeve (06AK) was removed, use an arbor (or hydraulic) press and a suitably sized dowel to press the new seat sleeve into the backhead from the back end of the backhead.

See **Pump Reassembly, Section E**, and assemble the housing assembly (04), backhead kit (06) and rotor/shaft assembly (03).

Clean the seal cavity with a cloth soaked in fresh cleaning solvent.



Most cleaning solvents are toxic and flammable. Use them only in a well ventilated area free from flame, sparks, and excessive heat. Read and follow all precautions printed on solvent containers.

Lubricate and install the shaft O-ring (05C).

Slide the cartridge seal assembly over the shaft sleeve until fully seated against the shoulder on the sleeve. Slide this subassembly onto the rotor shaft until the shaft sleeve seats squarely over the O-ring (05C) and against the shaft shoulder.

Assemble the rotor adjusting sleeve (07) and proceed with **Pump Reassembly, Section E**.

Barrier Liquid Recommendations

In general, a barrier liquid is **always** recommended. This requirement may be satisfied by a simple grease zerk, or it may become more complicated based on the application. The following barrier liquid guidelines are offered for maximum performance.

SEAL APPENDIX - SECTION F

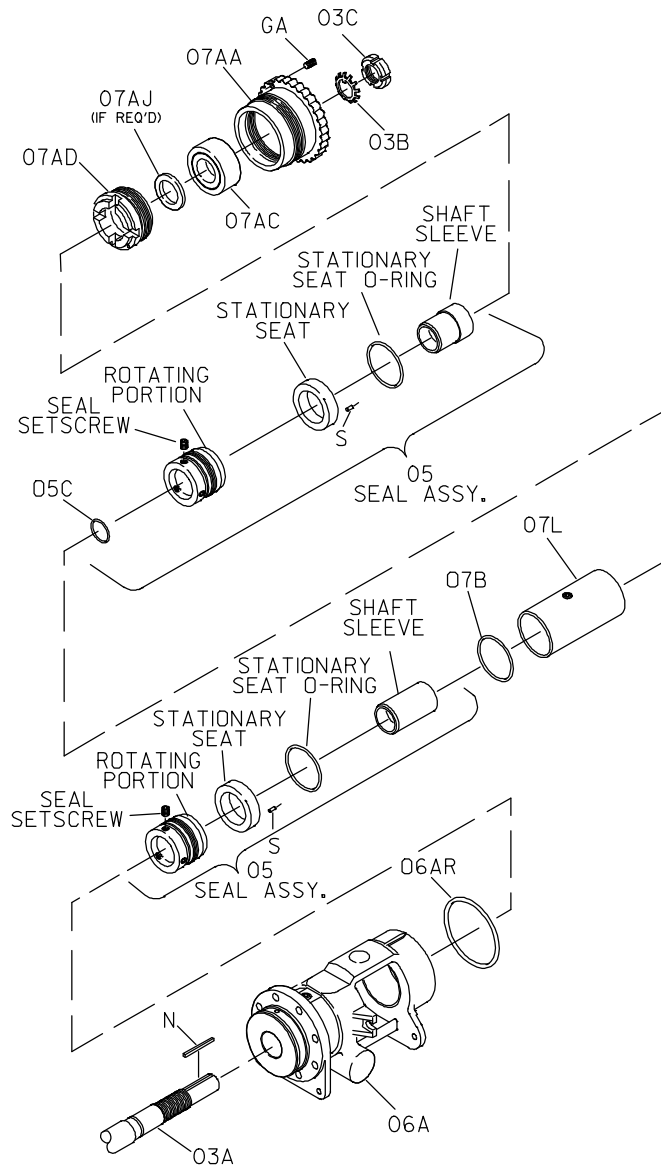
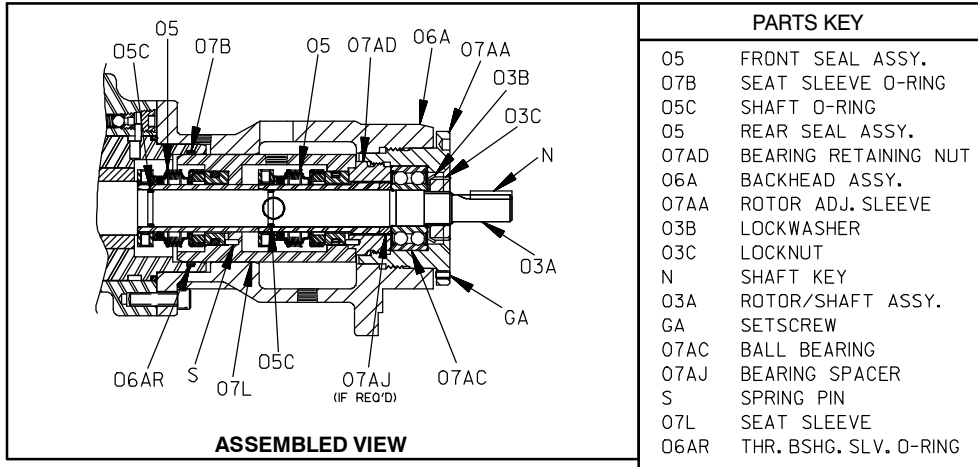

16703-9

Figure F-7. Option 60S Positive Locking Tandem Mechanical Seal (“D” Size Only)

Seal Removal

(Figures E-1 and F-7)

See **PUMP DISASSEMBLY** and disassemble the pump up to and including the **Rotor Adjusting Sleeve (07)**.

Reach into the backhead (06A) and slide the rear seal (05) off the shaft as an assembly.

If necessary, reach through the windows in the backhead with suitable prying devices and work the seat sleeve (07L) out of the backhead.

Remove the shaft O-ring (05C).

Remove the front seal stationary element and O-ring from the seat sleeve. **Use caution** not to damage the stationary element sealing face. Remove the O-ring (05C) from the O.D. of the seat sleeve.

Remove the foremost pipe plug (P). Use an allen wrench to loosen the setscrews in the collar of the front seal (05).

Slide the rotor/shaft back into the housing until the front seal is pushed toward the rear of the shaft. Pull the shaft toward the drive end of the housing until the front seal can be grasped and pulled off the shaft.

NOTE

Due to the complexity of design of the seal assemblies, seal disassembly for the purpose of reuse is not recommended. Replace the complete seal(s) when leakage occurs.

Continue as required with **PUMP DISASSEMBLY**.

Seal Installation

(Figures E-1 and F-2)

See **PUMP REASSEMBLY**, and assemble the housing assembly (04), backhead kit (06) and rotor/shaft assembly (03).

Clean the seal cavity and shaft with a cloth soaked in fresh cleaning solvent.



Most cleaning solvents are toxic and flammable. Use them only in a well ventilated area free from flame, sparks, and excessive heat. Read and follow all precautions printed on solvent containers.

Inspect the seal components for wear, scoring, grooves, and other damage that might cause leakage. If any components are worn, replace the complete seal; **never mix old and new seal parts**.

If replacement seals are being used, unwrap the seals and check that all components are preassembled, clean, undamaged and free of any foreign matter.



Seal components **must** be kept clean. Handle seal parts with extreme caution to prevent damage. Use care not to contaminate the precision-finished faces; even fingerprints on the faces can shorten seal life. If necessary to clean the faces, use a clean cloth and wipe in a circular pattern.

Position the pump on a flat surface with the drive end facing up. Lightly oil the shaft of the rotor/shaft assembly (03A) and install the O-ring (05C) in the groove in the shaft. Lightly lubricate the O-ring (06AR) in the back of the throttle bushing sleeve (06AD).

Slide the rotating portion of the front seal assembly onto the shaft until the collar is fully seated against the shaft shoulder. Reach through the hole for the foremost pipe plug (P) with an allen wrench and secure the seal collar to the shaft by tightening the collar setscrews.

Lubricate and install the O-ring (07B) in the groove in the O.D. of the seat sleeve (07L). Position the stationary element in the seat sleeve with the sealing face up. Cover the sealing face with a clean tissue and use thumb pressure to press the stationary element into the seat sleeve until fully seated.

Align the foremost pipe plug opening in the seat sleeve with the hole in the backhead and slide the

seat sleeve onto the shaft until the stationary element seats against the rotating element.

Slide the rear cartridge seal assembly into the rotor adjusting sleeve assembly until fully seated. Press the seat sleeve onto the rotor adjusting sleeve assembly (07AA) until fully seated.

Assemble the rotor adjusting sleeve (07) and seal unit, and proceed with **Pump Reassembly, Section E**.

Optional Reservoir Kit

An optional Reservoir Kit is available from the factory for applications requiring a barrier liquid to lubricate and protect the seal from the liquid being pumped.

Install the Reservoir Kit as shown in Figure F-2A and select a suitable barrier liquid according to the criteria shown in **Installation, Section B**. Fill the reservoir through the hole for the top fill plug (13AB) to the middle of the sight gauge (13AC) and maintain the liquid at this level.

Do not pressurize the reservoir. Pressurizing a tandem seal will cause the seal faces to separate, resulting in leakage and/or damage to the seal. The barrier liquid should be supplied at atmospheric pressure **only**.

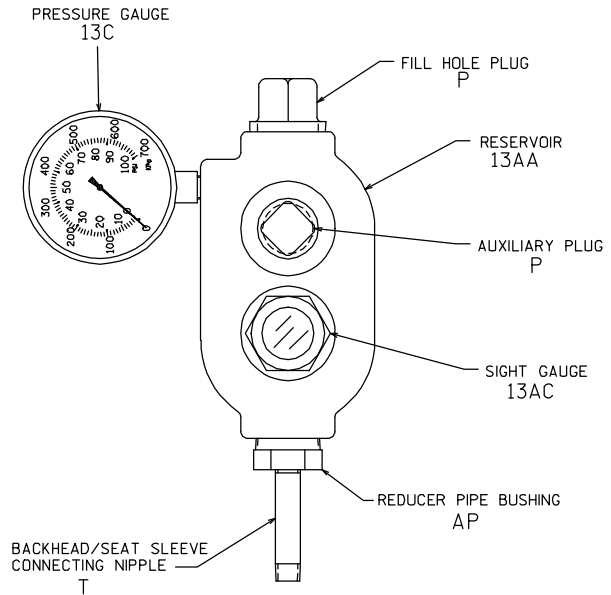

Figure F-2A. Reservoir Kit

Application Parameters	Environmental Control	
Less than 10,000 SSU AND Less than 100 fpm AND Less than 100 psi. AND Less than 150 F	No barrier liquid required, but is still recommended (for extended seal life).	
Greater than 150 psi. OR Thermally Sensitive ³	A pressurized barrier liquid ¹ is recommended.	Barrier at 25–50% of pump discharge pressure (minimum 25 psi.).
Greater than 300 F	A circulated barrier liquid ¹ is required, unless temperature can be controlled with a seal jacket.	Barrier at 25–50% of pump discharge pressure (minimum 25 psi.).
Mildly Abrasive	A circulated, pressurized barrier liquid ² is required.	Barrier liquid at pressure to ensure 2–3 gal/hour flow into process liquid.

1. Select a clean, lubricating liquid that is compatible with the pump construction (iron or 316 SST).
2. Select a clean, lubricating liquid that is compatible with the pumped product and with the pump construction (iron or 316 SST).

3. A pressurized barrier liquid may not be required if shaft surface speed is less than 100 fpm.

Note: To calculate fpm (feet per minute), multiply shaft diameter (in inches) by 3.14, then by rpm and divide by 12.

SEAL APPENDIX - SECTION F

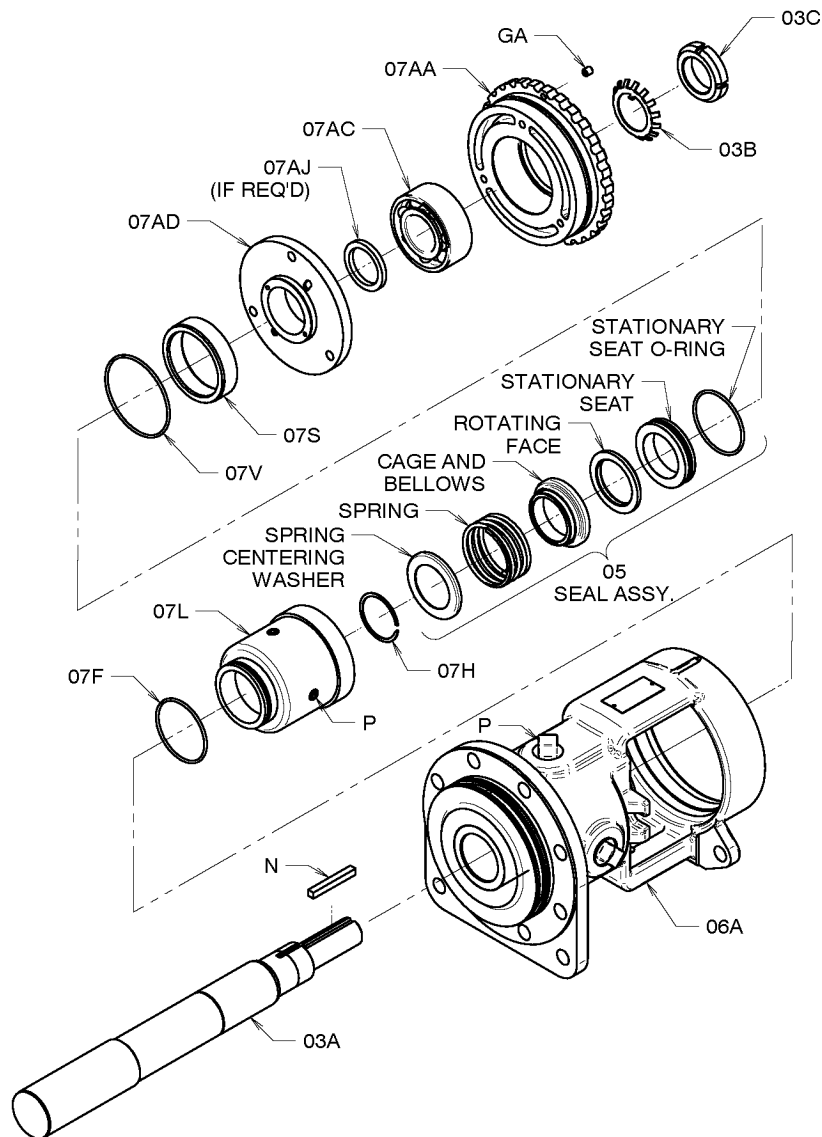
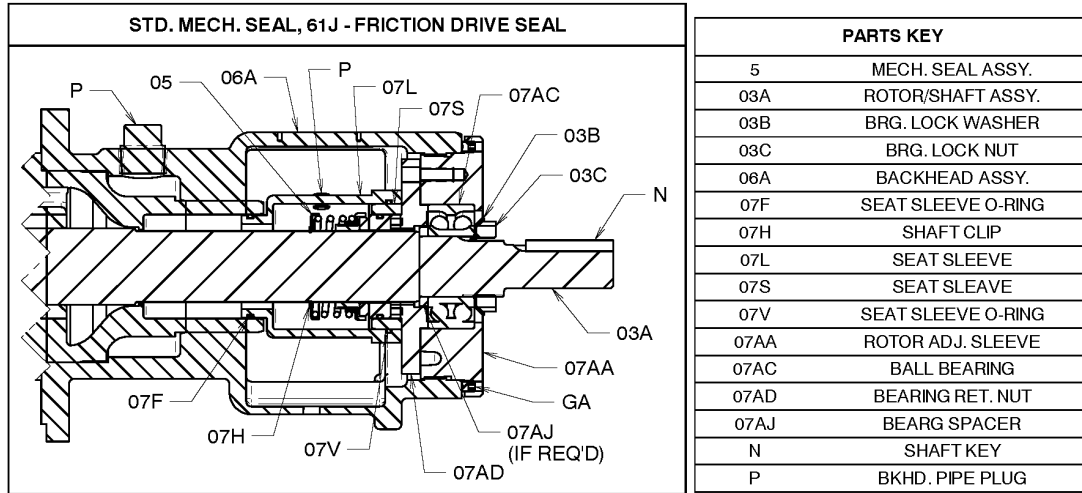

16703

Figure F-8. 61J Seal Assembly

Seal Removal

(Figures E-1 and F-8)

See **PUMP DISASSEMBLY** and disassemble the pump up to and including the **Rotor Adjusting Sleeve (07)**. As the rotor adjusting sleeve (07AA) is unscrewed from the backhead (06A), the seal stationary element will remain inside the intermediate seat sleeve (07S). The seat sleeve is a light press fit over the shoulder of the seat sleeve (07L). It is not necessary to remove the intermediate seat sleeve from the seat sleeve shoulder.

Remove the seal stationary element and O-ring from the intermediate seat sleeve. **Use caution** not to damage the stationary element sealing face.

Remove the seat sleeve O-ring (07V) from the groove in the I.D. of the seat sleeve.

Reach through the opening in the backhead and remove one of the pipe plugs (P) from tapped hole in the seat sleeve. Rotate the shaft until the set-screw(s) in the rotating portion of the seal (05) align with the pipe plug hole in the seat sleeve and use an allen wrench to loosen the seal setscrews.

Slide the rotating portion of the seal off the shaft.

Seal Installation

(Figures E-1 and F-8)

See **Pump Reassembly, Section E**, and assemble the housing assembly (04), backhead kit (06) and rotor/shaft assembly (03).

Clean the seal cavity and shaft with a cloth soaked in fresh cleaning solvent.



Most cleaning solvents are toxic and flammable. Use them only in a well ventilated area free from flame, sparks, and excessive heat. Read and follow all precautions printed on solvent containers.

The seal is not normally reused because wear patterns on the finished faces cannot be realigned during reassembly. This could result in premature failure. If necessary to reuse an old seal in an emer-

gency, **carefully** wash all metallic parts in fresh cleaning solvent and allow to dry thoroughly.

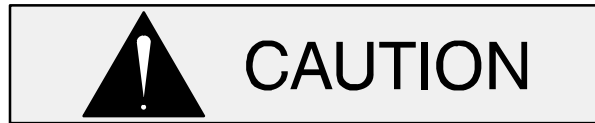

Seal components **must** be kept clean. Handle seal parts with extreme caution to prevent damage. Use care not to contaminate the precision-finished faces; even fingerprints on the faces can shorten seal life. If necessary to clean the faces, use a clean cloth and wipe in a circular pattern.

Inspect the seal components for wear, scoring, grooves, and other damage that might cause leakage. If any components are worn, replace the complete seal; **never mix old and new seal parts**.

If a replacement seal is being used, unwrap the cartridge seal components. Check that the seal faces are clean, undamaged and free of any foreign matter.

Position the pump on a flat surface with the drive end facing up. Lightly oil the shaft of the rotor/shaft assembly (03A).

Lightly lubricate the seat sleeve O-ring (07V) and install it in the groove in the I.D. of the seat sleeve (07L).

Push the rotating portion of the seal onto the lubricated shaft until fully seated against the retaining clip (07H).

Assemble the rotor adjusting sleeve (07) as described in **Pump Reassembly, Section E** and position it on a flat surface with the drive end down.

Lubricate the stationary seat O-ring with light oil. Place a clean tissue over the seal face of the seal stationary element. Align the spring pins (S) in the stationary element with the holes in the bearing retaining cap (07AD) and press the element into the bore of the intermediate seat sleeve (07L) until the pins are fully seated in the bearing retaining cap.

Remove the tissue and proceed with **Pump Reassembly, Section E**.

After setting the end clearance, tighten the seal setscrews and reinstall the pipe plug (P) in the seat sleeve.

O-RING APPENDIX - SECTION G

Ref. No.	Description	Hyd. Size	Dash No.
01C	Head to Housing	D	144
		G	152
		J	159
		N	164
		R	172
01E	Head Jacket to Head	D	021
		G	029
		J	135
		N	135
		R	145
06G	Housing to Backhead	D	144
		G	152
		J	159
		N	164
		R	172
06AR	Seat Sleeve to Bushing Sleeve	D	136
		G	143
		J	235
		N	235
		R	152
07B	Seat Sleeve to Backhead	D	133
		G	145
		J	152
		N	152
		R	152
07F	Seat Sleeve to Backhead	D	125
		G	133
		J	139
		N	139
		R	141
07V	Seat Sleeve to Intermediate Sleeve	D	031
		G	142
		J	150
		N	150
		R	152

Ref. No.	Description	Hyd. Size	Dash No.
09C	Shaft Sleeve to Shaft	D	015
		G	020
		J	123
		N	123
		R	126
10AG	Spring Guide to Bonnet	D	028
		G	028
		J	034
		N	034
		R	042
10AJ	Bonnet to Valve Body	D	033
		G	033
		J	040
		N	040
		R	045
10C	Valve or Coverplate to Head	D	021
		G	029
		J	135
		N	135
		R	145

O-RING FAMILY NUMBERS

5-DIGIT FAMILY	O-RING MATERIAL
25151—***	NEOPRENE®
25152—***	BUNA-N
25154—***	VITON®
25156—***	KALREZ®
25157—***	TEFLON®-ENCAPSULATED
25158—***	CHEMRAZ®

*** This number refers to the standard size.

NOTE: Neoprene, Kalrez, Teflon and Viton are Registered Trademarks of the DuPont Corp.
Chemraz is a Registered Trademark of Green, Tweed and Co.
Equivalent material may be substituted for all materials.

Table G-1. O-Ring Information Chart

JACKETED HEAD and BACKHEAD - APPENDIX H

GHS SST "D, G, J, N & R" JACKETED

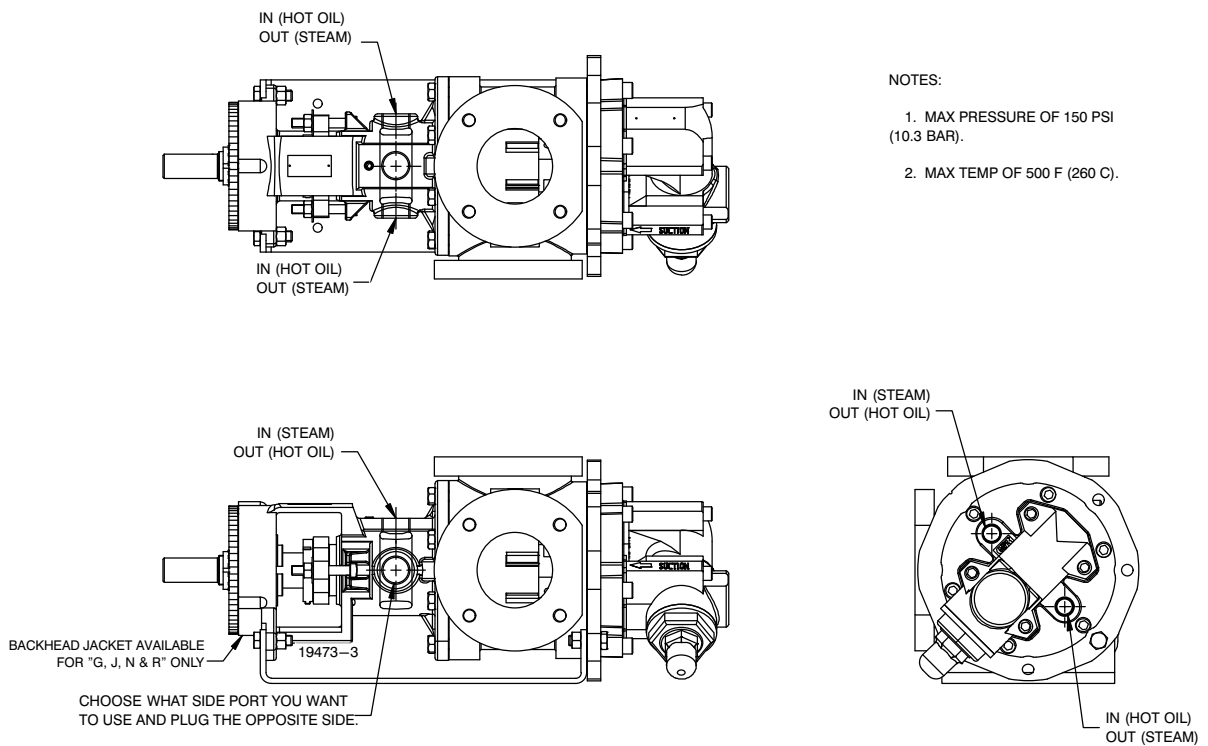

Figure H-1. Inlet / Outlet Location

**For Warranty Information, Please Visit
www.grpumps.com/warranty
or call:
U.S.: 419-755-1280
Canada: 519-631-2870
International: +1-419-755-1352**

GORMAN-RUPP PUMPS