

INSTALLATION, OPERATION, AND MAINTENANCE MANUAL



ROTARY GEAR PUMPS

MODELS
<p>GMS SERIES PUMPS D, G, J, N & R SIZES</p>

GORMAN-RUPP PUMPS

www.grpumps.com

Register your new
Gorman-Rupp pump online at
www.grpumps.com

Valid serial number and e-mail address required.

RECORD YOUR PUMP MODEL AND SERIAL NUMBER

Please record your pump model and serial number in the spaces provided below. Your Gorman-Rupp distributor needs this information when you require parts or service.

Pump Model: _____

Serial Number: _____

TABLE OF CONTENTS

INTRODUCTION	PAGE I – 1
SAFETY – SECTION A	PAGE A – 1
INSTALLATION – SECTION B	PAGE B – 1
PUMP MODEL DESIGNATION	PAGE B–1
PREINSTALLATION INSPECTION	PAGE B–2
STORAGE	PAGE B–2
Flushing	PAGE B–2
PUMP INSTALLATION	PAGE B–3
Lifting	PAGE B–3
Positioning The Pump	PAGE B–3
Mounting	PAGE B–3
Piping	PAGE B–3
Strainers	PAGE B–4
Gauges	PAGE B–4
Sealing	PAGE B–4
Valves	PAGE B–4
Barrier Liquids for Optional Double Lipseal	PAGE B–4
ALIGNMENT	PAGE B–4
Coupled Drives	PAGE B–4
V-Belt Drives	PAGE B–5
V-BELT TENSIONING	PAGE B–5
General Rules of Tensioning	PAGE B–5
Tension Measurement	PAGE B–6
ELECTRICAL CONNECTIONS	PAGE B–7
OPERATION – SECTION C	PAGE C – 1
PUMP OPERATION	PAGE C–1
PRE-OPERATION	PAGE C–1
Before Starting The Pump	PAGE C–1
Checking Pump Rotation	PAGE C–1
STARTING	PAGE C–1
OPERATION	PAGE C–2
Liquid Temperature	PAGE C–2
Overheating	PAGE C–2
Checking Gauges	PAGE C–2
Strainer Check	PAGE C–2
Leakage	PAGE C–2
PRESSURE RELIEF VALVE ADJUSTMENT	PAGE C–3
Cracking Pressure	PAGE C–3
Complete By-Pass Pressure	PAGE C–3
STOPPING	PAGE C–3
TROUBLESHOOTING – SECTION D	PAGE D – 1
TROUBLESHOOTING WITH GAUGES	PAGE D–1
TROUBLESHOOTING CHART	PAGE D–2
PREVENTIVE MAINTENANCE	PAGE D–3

TABLE OF CONTENTS

(continued)

PUMP MAINTENANCE AND REPAIR – SECTION E PAGE E – 1

PARTS KEY:

Typical GMS D, G, J And N Pump Models	PAGE E–3
Typical GMS R Pump Model	PAGE E–5
PUMP DISASSEMBLY	PAGE E–6
Preparing for Disassembly	PAGE E–7
Pressure Relief Valve (10)	PAGE E–7
Foot Bracket Kit (08)	PAGE E–7
Head/Idler Kit (01/02)	PAGE E–7
Gland Removal (04N)	PAGE E–7
Backhead Removal (06)	PAGE E–8
Rotor/Shaft Removal (03)	PAGE E–8
Seal Removal (05)	PAGE E–8
Housing Assembly (04)	PAGE E–8
PUMP REASSEMBLY	PAGE E–8
Cleaning and Inspection	PAGE E–8
Bushing Preparation	PAGE E–9
Housing Assembly (04)	PAGE E–9
Backhead Kit (06)	PAGE E–9
Rotor/Shaft Assembly (03)	PAGE E–9
Head/Idler Kit (01/02)	PAGE E–10
Seal Installation (05)	PAGE E–10
Gland Installation (04N)	PAGE E–10
Foot Bracket Kit (08)	PAGE E–10
SETTING END CLEARANCE	PAGE E–10
RELIEF VALVE DISASSEMBLY	PAGE E–11
RELIEF VALVE REASSEMBLY	PAGE E–12
Relief Valve (10) Installation	PAGE E–13

SEAL APPENDIX – SECTION F PAGE F–1

Standard Friction Drive And Optional 60A And 61J Mech. Seals	PAGE F–1
Lip Seal Option 65A	PAGE F–3
Positive Drive (Option 60D) Seal	PAGE F–5
Standard Packing Seal (Option 65)	PAGE F–7

O-RING APPENDIX – SECTION G PAGE G–1

INTRODUCTION

Thank You for purchasing a Gorman-Rupp Rotary Gear Pump. This manual is designed to help you achieve the best performance and longest life from your Gorman-Rupp Rotary Gear pump. **Read this manual** carefully to learn how to safely install, operate and repair your pump. Failure to do so could result in personal injury or damage to the pump.

This manual will alert personnel to known procedures which require special attention, to those which could damage equipment, and to those which could be dangerous to personnel. However, this manual cannot possibly provide detailed instructions and precautions for each specific application or for every situation that might occur during maintenance of the unit. Therefore, it is the responsibility of the owner, installer and/or maintenance personnel to ensure that applications and/or maintenance procedures not addressed in this manual are performed only after establishing that neither personal safety nor pump integrity are compromised by such applications or procedures.

In addition to this manual, a separate **Parts List** is shipped with the pump. Refer to the Parts List when ordering parts. If your pump is furnished with a drive unit, refer to the drive unit manufacturer's installation and operation instructions in the literature accompanying the pump.

These pumps can transfer a wide range of light, medium, and heavy viscosity liquids, depending on design and components. **Some models are not recommended for use with water; others when fitted with specific options, may be used with water; consult the factory.**

If there are any questions regarding the pump or drive unit which are not covered in this manual or in other literature accompanying this unit, please contact your Gorman-Rupp distributor or the Gorman-Rupp Company:

The Gorman-Rupp Company
P.O. Box 1217
Mansfield, Ohio 44901-1217
Phone: (419) 755-1011

or:

Gorman-Rupp of Canada Limited
70 Burwell Road
St. Thomas, Ontario N5P 3R7
Phone: (519) 631-2870

WARRANTY INFORMATION

The warranty provided with your pump is part of Gorman-Rupp's support program for customers who operate and maintain their equipment as described in this and the other accompanying literature. Please note that should the equipment be abused or modified to change its performance beyond the original factory specifications, the warranty will become void and any claim will be denied.

The following are used to alert personnel to procedures which require special attention, to those which could damage equipment, and to those which could be dangerous to personnel:



Immediate hazards which will result in severe personal injury or death. These instructions describe the procedure required and the injury which will result from failure to follow the procedure.



Hazards or unsafe practices which COULD result in severe personal injury or death. These instructions describe the procedure required and the injury which could result from failure to follow the procedure.



Hazards or unsafe practices which COULD result in minor personal injury or product or property damage. These instructions describe the requirements and the possible damage which could result from failure to follow the procedure.

NOTE

Instructions to aid in installation, operation, and maintenance or which clarify a procedure.

RECORDING MODEL AND SERIAL NUMBERS

Please record the pump model and serial number in the spaces provided below. Your Gorman-Rupp distributor needs this information when you require parts or service.

Pump Model: _____

Serial Number: _____

SAFETY – SECTION A

This information is specific to Gorman-Rupp GMS Series Rotary Gear Pumps. It applies throughout this manual and any manual or literature accompanying the pump.

In addition to this manual, see the separate literature covering the drive unit used to operate this pump.

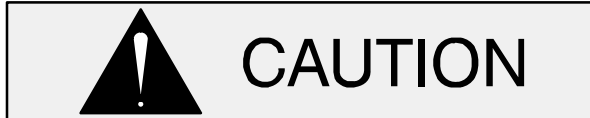

Pumps and related equipment must be installed and operated according to all national, local and industry standards.



This manual will alert personnel to known procedures which require special attention, to those which could damage equipment, and to those which could be dangerous to personnel. However, this manual cannot possibly provide detailed instructions and precautions for each specific application or for every situation that might occur during maintenance of the unit. Therefore, it is the responsibility of the owner, installer and/or maintenance personnel to ensure that applications and/or maintenance procedures not addressed in this manual are performed only after establishing that neither personal safety nor pump integrity are compromised by such applications or procedures.



Before attempting to install, operate, or service this pump, familiarize yourself with this manual, and with all other literature shipped with the pump. Unfamiliarity with all aspects of pump operation

covered in this manual could lead to destruction of equipment, injury, or death.



The standard version of this pump is designed to handle a wide range of light, medium, and heavy viscosity liquid, depending on design and components, and a range of temperatures when fitted with different seals. Do not apply at higher temperatures than the seal will handle. Do not attempt to pump liquids which may damage the pump or endanger personnel as a result of pump failure; consult the factory for chemical compatibility.



If the pump and motor are furnished mounted on a base, make certain that all lifting devices have adequate capacity. If chains or cables are used in lifting, make certain that they are positioned so as not to damage components, and so that the load will be balanced.



After the pump has been installed, make certain that the pump and all piping or hose connections are secure before operation. Loose connections can result in damage to the equipment and serious injury to personnel.



Never operate the pump without a pressure relief valve installed on the pump or in the discharge piping. Make certain that pump-mounted pressure relief

valves are installed with their adjusting ends toward the suction port. If bi-rotational operation is required, a pressure relief device must be provided for both directions of flow. Operation without a pressure relief valve or with an improperly installed relief valve could cause the pump to explode, resulting in serious injury or death to personnel.



Before attempting to open or service the pump:

1. Familiarize yourself with this manual.
2. Lock out incoming power to the drive unit to ensure that the pump will remain inoperative.
3. Allow the pump to completely cool if overheated.
4. Close the discharge and suction valve (if used).



An overheated pump can cause severe burns and injury. If overheating occurs:

1. Stop the pump immediately.
2. Allow the pump to completely cool.

3. Refer to the instructions in this manual before restarting the pump.



Do not remove plates, covers, gauges, pipe plugs or fittings from an overheated pump. Vapor pressure within the pump can cause parts being disengaged to be ejected with great force. Allow the pump to completely cool before servicing.



Do not operate this pump without guards in place over the rotating parts. Exposed rotating parts can catch clothing, fingers or tools, causing severe injury to personnel.



This pump may be used to handle liquids which may cause serious illness or injury through direct exposure or emitted fumes. Wear protective clothing, such as rubber gloves, face mask and rubber apron, as necessary, before disconnecting or servicing the pump or piping.

INSTALLATION – SECTION B

Review all SAFETY information in Section A.

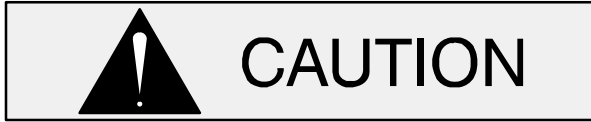

Pumps and related equipment must be installed and operated according to all national, local and industry standards.

Since pump installations are seldom identical, this section is intended only to summarize general recommendations and practices required to inspect, position, and arrange the pump and piping. If there are any questions concerning your specific installation, contact your Gorman-Rupp distributor or the Gorman-Rupp Company.

Most of the information applies to a flooded suction installation where liquid is supplied under pressure.

If the pump is positioned above the liquid in a static lift installation, information such as mounting, piping configuration and priming must be tailored to specific conditions.

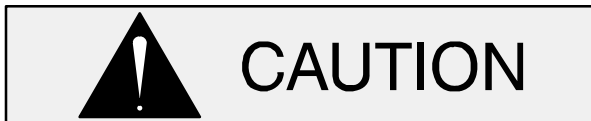

These pumps are not recommended for use with water. Some models, when fitted with specific options, may be used with water; consult the factory.

PUMP MODEL DESIGNATION

Following is a description of the model numbering system for Gorman-Rupp rotary gear pumps. Rotary gear pump model numbers include design style, port size, hydraulic size and construction code.

Typical Pump Model

GHS	1 1/2	GF	32
Design Style	Port Size	Hydraulic Size	Construction Code

Design Style: Gorman-Rupp rotary gear pumps are available in five basic designs:

- GMC – Medium Duty – Compact
- GMS – Medium Duty
- GHC – Heavy Duty – Compact
- GHS – Heavy Duty
- GHA – Abrasive Duty

Port Size: Gorman-Rupp rotary gear pumps are available in port sizes from 1 to 6 inches, depending on the design style. Consult your Gorman-Rupp distributor or the factory for additional sizes.

Hydraulic Size: The first letter in the hydraulic size is a rotor diameter code. The second letter indicates tooth length.

Construction Code: Construction Codes for Gorman-Rupp rotary gear pumps are as follows:

Code	Description
3	Iron w/Mechanical Seal(s)
4	Iron w/Packing or Lip Seal(s)
9	316 SST w/Mechanical Seal(s)
10	316 SST w/Packing or Lip Seal(s)
32	Steel w/Mechanical Seal(s)
38	Steel w/Packing or Lip Seal(s)

Theoretical Displacement: Table B-1 indicates theoretical displacement values for each hydraulic size.

NOTE

Actual capacities and recommended shaft speeds vary according to application. Consult your Gorman-Rupp distributor or the factory for additional information.

Table B-1. Theoretical Displacement

Hydraulic Size	Theoretical Displacement Per Revolution	
	Gallons	Centimeters ³
DC	0.00568	21.486
DE	0.00704	26.646
GC	0.00967	36.619
GF	0.01405	53.186
GH	0.01915	72.479
GJ	0.02317	87.700
JG	0.03579	135.49
JJ	0.05159	195.28
JL	0.07078	267.94
JP	0.10078	381.48
NK	0.10665	403.71
NM	0.14173	536.51
NP	0.17681	669.31
RM	0.24030	909.65
RP	0.29979	1134.8
RR	0.35927	1360.0
RS	0.41876	1585.1
SR	0.65752	2489.0
SU	1.10240	4173.2
TU	1.91280	7240.7

PREINSTALLATION INSPECTION

The pump assembly was inspected and tested before shipment from the factory. Before installation, check for damage which may have occurred during shipment. Check as follows:

- a. Inspect the pump assembly for cracks, dents, damaged threads, and other obvious damage.
- b. Check for loose attaching hardware. Since gaskets tend to shrink after drying, check for loose hardware at the mating surfaces.
- c. Carefully read all tags, decals, and markings on the pump assembly, and perform all duties indicated.

STORAGE



Due to the extreme close machining tolerances within rotary gear pumps, proper storage before installation is essential to prevent damage to the pump.

If the pump will not be immediately installed, follow these procedures or damage to the pump will occur.

- a. **Do not** flush the pump. Ensure that the port plugs shipped with the pump remain in place until piping is installed to help prevent dust or other foreign objects from entering the pump.
- b. Pumps that will not be installed for an extended period should be stored indoors if possible. The factory-installed port plugs will **not** ensure protection from excessive humidity, splash water or rain. In very humid or wet conditions, install air-tight plugs in the ports and fill the pump completely with a lubricating preservative liquid that is compatible with the liquid to be pumped.
- c. Pumps stored outdoors **must be fully preserved** as described above, **completely covered** with plastic or other water-tight material, and the covering anchored to ensure that it will not be blown off.

Flushing



Clean piping is essential because of close-tolerance moving parts in this pump. Flush all dirt, grit, weld beads or scale from the suction piping before installing the pump. Damage to the pump because of debris in the suction line is not covered by the pump warranty.

The pump may have been tested using a petroleum-based preservative, or a preservative may have been used for long-term storage of the pump. If flushing is required, do not do so until just before installation; the test oil protects close-tolerance pump parts from corrosion.



Most cleaning solvents are toxic and flammable. Use them only in a well ventilated area free from flame, sparks, and excessive heat. Read and follow all precautions printed on solvent containers.

To flush the pump, use an approved solvent compatible with the liquid being pumped. **Make certain that the solvent will not attack pump components, particularly seals and gaskets.**

PUMP INSTALLATION

Pump dimensions are shown in the separate Pump Specification Bulletin.



Never operate the pump without a pressure relief valve installed on the pump or in the discharge piping. Make certain that pump-mounted pressure relief valves are installed with their adjusting ends toward the suction port. If bi-rotational operation is required, a pressure relief device must be provided for both directions of flow. Operation without a pressure relief valve or with an improperly installed relief valve could cause the pump to explode, resulting in serious injury or death to personnel.

Lifting

Pump unit weights will vary depending on the mounting and drive provided. Check the shipping tag on the unit packaging for the actual weight, and use lifting equipment with appropriate capacity. Drain the pump and remove all customer-installed equipment such as suction and discharge hoses or piping before attempting to lift existing, installed units.

Positioning The Pump

Locate the pump as close as possible to the liquid being pumped. Locating the pump below the liquid source will help self-priming and reduce the possibility of cavitation.

Mounting

The pump may be shipped alone, mounted on a base, or with pump and motor mounted on a base.

Install the pump and motor on a base before mounting the base on a foundation.

Mount the base on a foundation that will provide permanent, rigid support for the pump, and will be heavy enough to absorb any vibration, strain or shock.

Piping

Before establishing suction and discharge lines, determine pump port positions and rotation. Figure B-1 shows typical port positions for the standard 90° housing; if you have selected a 180° housing port option, your port positions will be different.

Begin piping layout at the pump, and work toward the source of supply and the point of discharge.

Either hose or rigid pipe may be used to make connections. If rigid piping is used, install expansion joints to protect the pump from vibration and thermal expansion in the piping. Do not use expansion joints or flexible connectors to adjust misaligned piping.

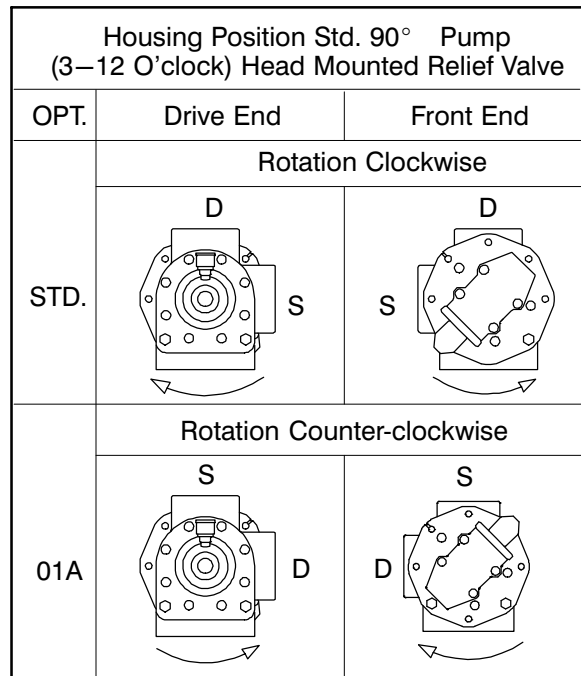

Figure B-1. Typical Port Positions & Rotation

The discharge and suction lines must be independently supported to avoid vibration and strain on the pump. For maximum pumping capacity, keep the lines as short and straight as possible. EI-

bows and fittings used in the lines increase friction losses; minimize their use. Reducers used in suction lines should be the eccentric type installed with the flat part uppermost to avoid creating air pockets.

Before tightening a connection or flange, align it exactly with the pump port. Never pull a pipe line into place by tightening the flange bolts and/or couplings.

Strainers

Because of the close-tolerance moving parts of this pump, it is recommended that a strainer be installed in the suction line. The strainer should be large enough to prevent excessive vacuum, and capable of operating under high vacuum without collapsing. The net open area of the strainer screen depends on liquid viscosity and desired flow rate; in any case, the sum of the area of all the holes in the screen should be three to five times the area of the suction pipe.

Gauges

To monitor operation and assist in troubleshooting, a vacuum gauge and a pressure gauge should be installed on the pump.

Sealing

Even a slight leak will affect priming, head, and capacity, especially in a suction lift application. Seal all piping joints, valves and gauges with pipe dope or teflon tape. The sealing material should be compatible with the liquid being pumped.

Valves

To avoid air pockets, install piping valves with the stem horizontal.

To prevent leakage during shutdown, install a shut-off valve in the discharge line, particularly on a flooded suction application. Shutoff valves are not recommended for suction lines.

It is **not** recommended that a foot valve be installed at the end of the suction line. If desired to install a foot valve, consult the factory.

When handling very hot or cold liquids, install a pressure relief valve in any part of the system that can be valved off or isolated; this will protect piping against damage from liquid thermal expansion or contraction from temperature changes during shutdown.

Barrier Liquids for Optional Double Lipseal

In general, a barrier liquid is **always** recommended for these seals. This requirement may be satisfied by a simple oiler, or it may become more complicated based on the application. The following barrier liquid guidelines are offered for maximum performance;

1. Select a clean, lubricating liquid that is compatible with the pumped product and with the pump construction (iron or 316 SST).
2. Depending upon pump shaft speed, a pressurized barrier liquid may not be required. Consult the factory for your specific application.

ALIGNMENT



Make certain that power to the drive unit is disconnected before attempting to connect the pump drive; otherwise, personal injury may result.

NOTE

See **ROTATION** in Section C before mounting the pump on the base.

Coupled Drives

When using couplings, the axis of the power source must be aligned to the axis of the pump shaft in both the horizontal and vertical planes. Most couplings require a specific gap or clearance between the driving and the driven shafts. Refer to the coupling manufacturer's service literature.

Align spider insert type couplings by using calipers to measure the dimensions on the circumference of the outer ends of the coupling hub every 90°.

The coupling is in alignment when the hub ends are the same distance apart at all points (see Figure B-2).

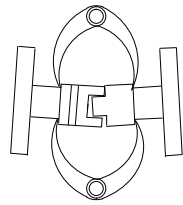

Figure B-2. Spider-type Couplings

Align non-spider type couplings by using a feeler gauge or taper gauge between the coupling halves every 90°. The coupling is in alignment when the hubs are the same distance apart at all points (see Figure B-3).

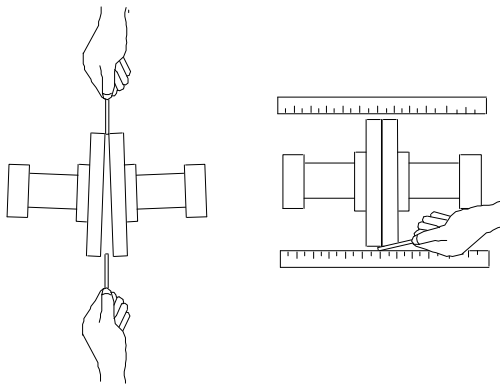

Figure B-3. Aligning Non-Spider Type Coupling

Check parallel adjustment by laying a straightedge across both coupling rims at the top, bottom, and side. When the straightedge rests evenly on both halves of the coupling, the coupling is in horizontal parallel alignment. If the coupling is misaligned, use a feeler gauge between the coupling and the straightedge to measure the amount of misalignment.

V-Belt Drives



GMS style pumps will require an external bearing support when using V-belt drives.

When using V-belt drives, the power source and the pump must be parallel. Use a straightedge along the sides of the pulleys to ensure that they are properly aligned (see Figure B-4). In drive systems using two or more belts, make certain that the belts are a matched set; unmatched sets will cause accelerated belt wear.

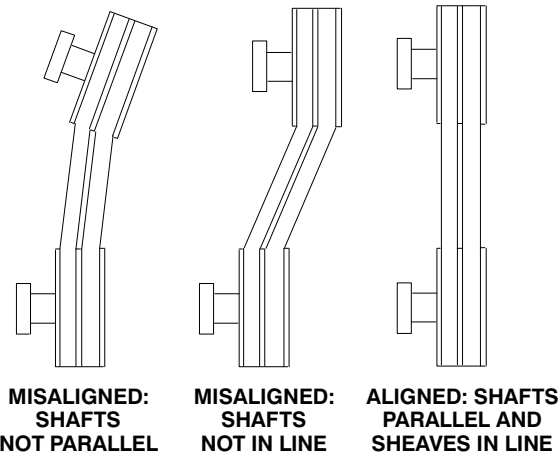

Figure B-4. V-belt Alignment

Tighten the belts in accordance with the belt manufacturer's instructions. If the belts are too loose they will slip; if they are too tight, there will be excessive power loss and possible bearing failure.

Select pulleys to match the proper speed ratio; overspeeding the pump may damage both pump and power source.



Do not operate this pump without guards in place over the rotating parts. Exposed rotating parts can catch clothing, fingers or tools, causing severe injury to personnel.

V-BELT TENSIONING

General Rules of Tensioning

For new v-belts, check the tension after 5, 20 and 50 hours of operation and re-tension as required (see the following procedure for measuring belt tension). Thereafter, check and re-tension if required monthly or at 500 hour intervals, whichever comes first.

Ideal v-belt tension is the **lowest** tension at which the belt will not slip under peak load conditions. Do not over-tension v-belts. Over-tensioning will shorten both v-belt and bearing life. Under-tensioning will cause belt slippage. Always keep belts free from dirt, grease, oil and other foreign material which may cause slippage.

Tension Measurement

Correct v-belt tension can be achieved using a v-belt tension tester and Table B-2 or B-3. Use the tables to find the v-belt size (cross-section), the smallest sheave diameter, the belt type for your application. The corresponding deflection force required for new or used belts is shown opposite the RPM range of the pump.

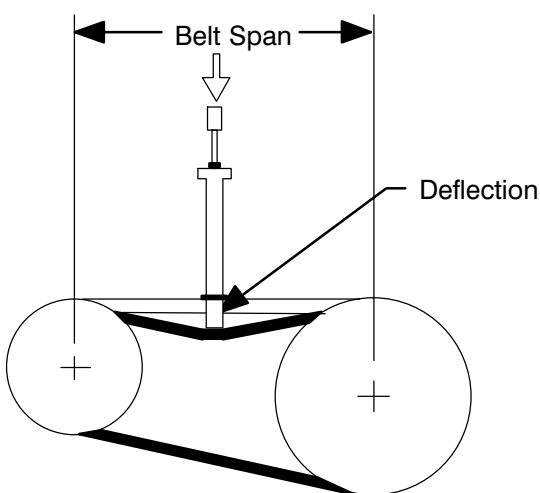

Figure B-5. Belt Tension Measurement

The ratio of deflection to belt span is 1:64 for both ASA and metric units. Therefore, a belt with a span

of 64 inches would require a deflection of 1 inch at the force shown on the Tables for your particular application.

For example, if the span as measured in Figure B-5 is 32 inches (813 mm), the v-belt cross-section is C, the smallest sheave diameter is 8 inches, the pump speed is 1250 RPM, and the belts are uncogged Yy-T type, then 11.5 lbs. of force on the tensioner should show 1/2-inch (12,7 mm) of deflection.

A tension tester is available as an option from Gorman-Rupp (P/N 29513-001). Other tension testers are available from your local belt/sheave distributor, and work on a similar principal.

To use the Gorman-Rupp tensioner, measure the belt span as shown in Figure B-5. Position the bottom of the large O-ring on the span scale of the tensioner at the measured belt span. Set the small O-ring on the deflection force scale to zero.

Place the tension tester squarely on the belt at the center of the belt span. Apply force on the plunger, perpendicular to the belt span, until the bottom of the large O-ring is even with the top of the next belt, or with the bottom of a straight edge laid across the sheaves.

Read the force applied from the bottom of the small O-ring on the deflection force scale. Compare this force with the value shown in Table B-2 or B-3 and adjust the tension accordingly. Note that the **tension for new belts is higher than that for used belts** to allow for expected belt stretching. **Do not** over-tension used belts to the higher deflection forces shown for new belts.

**Table B-2. Sheave Diameter (In.)
Deflection Force (Lbs.)**

Cross Section	Smallest Sheave Diameter Range	R.P.M. Range	Belt Deflection Force			
			Uncogged Hy-T Belts & Uncogged Hy-T Torque Team		Cogged Torque-Flex & Machined Edge torque Team Belts	
			Used Belt	New Belt	Used Belt	New Belt
A,AX	3.0 - 3.6	1000-2500 2501-4000	3.7 2.8	5.5 4.2	4.1 3.4	6.1 5.0
	3.8 - 4.8	1000-2500 2501-4000	4.5 3.8	6.8 5.7	5.0 4.3	7.4 6.4
	5.0 - 7.0	1000-2500 2501-4000	5.4 4.7	8.0 7.0	5.7 5.1	9.4 7.4
B,BX	3.4 - 4.2	860-2500 2501-4000			4.9 4.2	7.2 6.2
	4.4 - 5.6	860-2500 2501-4000	5.3 4.5	7.9 6.7	7.1 7.1	10.5 9.1
	5.8 - 8.6	860-2500 2501-4000	6.3 6.0	9.4 8.9	8.5 7.3	12.6 10.9
C,CX	7.0 - 9.0	500-1740 1741-3000	11.5 9.4	17.0 13.8	14.7 11.9	21.8 17.5
	9.5 - 16.0	500-1740 1741-3000	14.1 12.5	21.0 18.5	15.9 14.6	23.5 21.6
D	12.0 - 16.0	200-850 851-1500	11.5 9.4	17.0 13.8	14.7 11.9	21.8 17.5
	18.0 - 20.0	200-850 851-1500	30.4 25.6	45.2 38.0		
3V, 3VX	2.2 - 2.4	1000-2500 2501-4000			3.3 2.9	4.9 4.3
	2.65 - 3.65	1000-2500 2501-4000	3.6 3.0	5.1 4.4	4.2 3.8	6.2 5.6
	4.12 - 6.90	1000-2500 2501-4000	4.9 4.4	7.3 6.6	5.3 4.9	7.9 7.3
5V, 5VX	4.4 - 6.7	500-1749 1750-3000 3001-4000			10.2 8.8 5.6	15.2 13.2 8.5
	7.1 - 10.9	500-1740 1741-3000	12.7 11.2	18.9 16.7	14.8 13.7	22.1 20.1
	11.8 - 16.0	500-1740 1741-3000	15.5 14.6	23.4 21.8	17.1 16.8	25.5 25.0
8V	12.5 - 17.0	200-850 851-1500	33.0 26.8	49.3 39.9		
	18.0 - 22.4	200-850 851-1500	39.6 35.3	59.2 52.7		

**Table B-3. Sheave Diameter (Mm.)
Deflection Force (Kg.)**

Cross Section	Smallest Sheave Diameter Range	R.P.M. Range	Belt Deflection Force			
			Uncogged Hy-T Belts & Uncogged Hy-T Torque Team		Cogged Torque-Flex & Machined Edge torque Team Belts	
			Used Belt	New Belt	Used Belt	New Belt
A,AX	75 - 90	1000-2500 2501-4000	1.7 1.3	2.5 1.9	1.9 1.5	2.8 2.3
	91 - 120	1000-2500 2501-4000	2.0 1.7	3.1 2.6	2.3 2.0	3.4 2.9
	125 - 175	1000-2500 2501-4000	2.4 2.1	3.6 3.2	2.6 2.3	4.3 3.4
B,BX	85 - 105	860-2500 2501-4000			2.2 1.9	3.3 2.8
	106 - 140	860-2500 2501-4000	2.4 2.0	3.6 3.0	3.2 3.2	4.8 4.1
	141 - 220	860-2500 2501-4000	2.9 2.7	4.3 4.0	3.9 3.3	5.7 4.9
C,CX	175 - 230	500-1740 1741-3000	5.2 4.3	7.7 6.3	6.7 5.4	9.9 7.9
	231 - 400	500-1740 1741-3000	6.4 5.7	9.5 8.4	7.2 6.6	10.7 9.8
D	305 - 400	200-850 851-1500	11.3 9.6	16.8 14.2		
	401 - 510	200-850 851-1500	13.8 11.6	20.5 17.2		
3V, 3VX	55 - 60	1000-2500 2501-4000			1.5 1.3	2.2 2.0
	61 - 90	1000-2500 2501-4000	1.6 1.4	2.3 2.0	1.9 1.7	2.8 2.5
	91 - 175	1000-2500 2501-4000	2.2 2.0	3.3 3.0	2.4 2.2	3.6 3.3
5V, 5VX	110 - 170	500-1749 1750-3000 3001-4000			4.6 4.0 2.5	6.9 6.0 3.9
	171 - 1275	500-1740 1741-3000	5.8 5.1	8.6 7.6	6.7 6.2	10.0 9.1
	276 - 400	500-1740 1741-3000	7.0 6.6	10.6 9.9	7.8 7.6	11.6 11.3
8V	315 - 430	200-850 851-1500	15.0 12.2	22.4 18.1		
	431 - 570	200-850 851-1500	18.0 16.0	26.8 23.9		

ELECTRICAL CONNECTIONS

Before connecting an electric motor to incoming power, check that the electrical service available matches the pump motor requirements stamped on the motor nameplate.



The electrical power used to operate this pump is high enough to cause injury or death. Obtain the services of a qu-

alified electrician to make all electrical connections.



Do not install and operate a non-explosion proof motor in an explosive atmo-

sphere. Install, connect, and operate the motor in accordance with The National Electrical Code and all local codes. If there is a conflict between the instructions in the manual accompanying the unit and The National Electrical Code or the applicable local code, The National or local code shall take precedence.

OPERATION – SECTION C

Review all **SAFETY** information in Section A.

Follow the instructions on all tags, labels and decals attached to the pump.

PUMP OPERATION



Pressure relief valves are designed to operate as safety devices and should never be used to regulate liquid flow. Otherwise, the pump or piping may explode and cause personal injury or death.

PRE-OPERATION

Make certain that all instructions in **INSTALLATION**, Section B have been carried out.

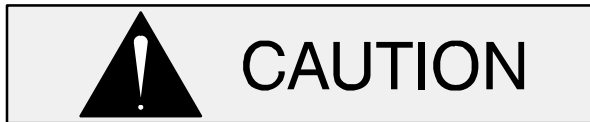

The standard version of the pump is designed to handle a wide range of light, medium, and heavy viscosity liquids, depending on design and components. Do not install the pump in a service with higher liquid temperatures than what it was designed; otherwise, pump components and operation may be affected. For temperature range consult The Gorman-Rupp Company.

Before Starting The Pump



Never operate the pump against a closed suction or discharge valve. The pump will overheat, and may rupture or explode, causing personal injury or death.

Open all valves in the suction and discharge lines, and close all drain valves.

Consult the drive manufacturer's operating manual before attempting to start the drive.

In a suction lift, fill the pump housing with liquid to seal clearances and to lubricate.

Checking Pump Rotation

Correct rotation of your pump is shown on the pump serial plate or direction arrow plate.



In applications with a single direction of flow and a single pump-mounted pressure relief valve, make certain that the drive unit turns the pump in the correct direction of rotation. Otherwise, the pump-mounted pressure relief valve will not function.

Follow the drive unit manufacturer's instructions, jog the pump motor **briefly**, and check rotation.

If a 3-phase motor is being used and rotation is incorrect, have a qualified electrician interchange any two of the 3-phase wires to change the direction of rotation. If a 1-phase motor is being used and rotation is incorrect, consult the motor manufacturer's literature.

STARTING

Start the drive unit as indicated in the manufacturer's instructions and observe the suction and discharge gauges. If the pump does not deliver liquid within one minute, stop the drive unit. **Do not** operate the pump more than one minute without liquid in it; dry operation will damage or destroy the pump.



Although this pump is self-priming, never operate it dry. Dry operation could cause

galling, seizing, damage to the seal or excessive wear of rotating parts.

Review the previous steps outlined in **PRE-OPERATION** and review **TROUBLESHOOTING**, Section D. If everything appears normal, add liquid to the pump housing to assist priming and start the driver again.

If the pump does not deliver liquid within two minutes, stop the pump; it may be necessary to vent the discharge line until liquid begins to flow.

If the pump still does not deliver after consulting **TROUBLESHOOTING** and venting the discharge line, contact your local Gorman-Rupp Rotary Gear Distributor or the factory.

OPERATION

NOTE

*If the pump malfunctions or does not meet operating specifications, refer to **TROUBLESHOOTING – Section D.***

A change in operating noise when liquid first enters the pump is normal. After the pump is fully operational, monitor it for any unusual noises or vibration; if either occurs, shut the pump down immediately.

Liquid Temperature

Do not install the pump in a service with higher liquid temperatures than what it was designed. Introducing hot liquid into a cold pump will expand parts unevenly, causing excessive wear, pump failure, and operation may be affected. This thermal shock can be reduced by gradually heating the liquid being introduced into the pump. If it is not possible to heat the liquid, use heat tape and/or insulation to heat the pump.

High temperature bushings as well as optional jackets which may be used to heat or cool the pump are available options for many models.

Overheating

Overheating can occur if the pump is operated with valves in the suction or discharge lines closed. Op-

erating against closed valves could bring the liquid to a boil, build pressure, and cause the pump to rupture or explode. If overheating occurs, stop the pump and allow it to completely cool before servicing.



Do not remove plates, covers, gauges, pipe plugs or fittings from an overheated pump. Vapor pressure within the pump can cause parts being disengaged to be ejected with great force. Allow the pump to completely cool before cooling.

Checking Gauges

Monitor vacuum and pressure gauge readings to ensure that the pump is operating within normal range and delivering full flow.

Strainer Check

If a strainer has been installed in the suction line, monitor vacuum gauge readings to detect blockage. Check the strainer if flow rate begins to drop.



Never introduce air or steam pressure into the pump housing to remove a blockage. This could result in personal injury or damage to the equipment. If backflushing is absolutely necessary, limit liquid pressure input to 50% of the maximum permissible operating pressure shown in the pump performance data.

Leakage

No leakage should be visible at pump mating surfaces or at pump connections or fittings. Keep all line connections and fittings tight to maintain maximum efficiency.

If your pump is equipped with a packing seal, the packing is lubricated by the liquid being pumped. Some leakage around the packing seal is normal.

Packing pumps **must leak slightly** to cool and lubricate the shaft and to allow the shaft to turn freely.

Wait until the pump has run long enough to reach its normal operating temperature to adjust the gland nuts. Adjust the nuts only tight enough to reduce excessive leakage.

PRESSURE RELIEF VALVE ADJUSTMENT

Some pumps are not provided with a pressure relief valve. A pressure relief valve must be installed on the pump or in the discharge piping to ensure safe operation. Otherwise, the pump may be damaged and personnel injured.



If operating at high temperatures, allow the pump to completely cool before attempting any adjustments.

Cracking Pressure

Cracking pressure is the pressure at which the pressure relief valve first begins to open and by-pass fluid. The nominal cracking pressure of the relief valve provided with this pump is set at the factory and is indicated on the tag attached to the relief valve.

If the nominal cracking pressure set at the factory must be changed, see Table E-2 and instructions in **Section E - MAINTENANCE AND REPAIR**.

Complete By-pass Pressure

Complete by-pass pressure is the maximum pressure the pump will see when all the pumped fluid is being by-passed through the pressure relief valve. This pressure will vary depending on the cracking pressure setting, liquid viscosity, and pump speed (pump capacity).

To determine the complete by-pass pressure, refer to the pump performance chart or consult the factory.



Do not remove the adjusting screw jam nut; with the jam nut removed the relief valve spring(s) can be compressed too far for the valve to open. If the valve does not open, excessive pressure can develop, causing damage to the pump and possible injury to personnel.

STOPPING

If the pump will be out of service for an extended length of time, particularly when handling non-lubricating liquids, drain the system and flush the pump and piping with an oil-based preservative to protect close-tolerance pump parts.

When handling liquids that solidify when at rest (tar, glue, etc.), flush the pump and piping with an approved solvent compatible with the pump components and the liquids being pumped.

TROUBLESHOOTING – SECTION D

Review all **SAFETY** information in Section A.



Before attempting to open or service the pump:

1. **Familiarize yourself with this manual.**
2. **Allow the pump to completely cool if overheated.**
3. **Check the temperature before opening any covers, plates, or plugs.**
4. **Close the suction and discharge valves.**
5. **Drain the pump.**

TROUBLESHOOTING WITH GAUGES

Most pump or system malfunctions can be detected by installing vacuum suction and discharge pressure gauges. Read the gauges and refer to the following information for interpretation of the gauge readings. For additional troubleshooting procedures, see the **TROUBLESHOOTING CHART**.

Vacuum Gauges

HIGH READING

Suction valve closed, suction line blocked, foot valve jammed, strainer blocked.
Liquid too viscous.
Lift too high.
Suction line undersized.

LOW READING

Air leak in suction line.
End of suction line not submerged.
Pump parts worn or defective.
Pump needs priming.

ERRATIC READING

Liquid overheated, vaporizing.
Liquid entering intermittently, suction air leak, end of suction line not submerged.
Vibration from cavitation, misalignment, damaged parts.

Pressure Gauges

HIGH READING

Liquid too viscous.
Discharge line undersized or too long.
Discharge valve partially closed.
Strainer blocked.
Relief valve pressure set too high.
Thermal changes in liquid.

LOW READING

Relief valve pressure set too low.
Internal valve not seating properly.
Pump bypass partially open.
End clearance too great.
Pump parts worn or defective.

ERRATIC READING

Cavitation.
Liquid entering intermittently, suction air leak, end of suction line not submerged.
Drive misalignment causing vibration.

TROUBLESHOOTING CHART

TROUBLE	POSSIBLE CAUSE	PROBABLE REMEDY
PUMP FAILS TO PRIME OR LOSES PRIME	<p>Air leak in suction line; end of suction line not submerged; foot valve blocked or jammed; insufficient liquid in sump or tank.</p> <p>Suction strainer clogged.</p> <p>Shaft seal leaking; gaskets, O-rings worn.</p> <p>Leaking relief valve.</p> <p>Suction lift too high.</p> <p>Pump "starving" or liquid vaporizing in suction line.</p> <p>Pump rotation incorrect.</p> <p>Pump speed too slow.</p> <p>Housing dry.</p>	<p>Check and correct as required.</p> <p>Check strainer.</p> <p>Check vacuum gauge; disassemble pump and replace faulty parts.</p> <p>Disassemble and repair.</p> <p>See INSTALLATION, SECTION B and check piping.</p> <p>Increase suction pipe size or reduce length; position pump below liquid level.</p> <p>See OPERATION, SECTION C and check rotation.</p> <p>Check driver speed.</p> <p>Add liquid to housing, see OPERATION, SECTION C.</p>
PUMP DOES NOT DELIVER RATED DISCHARGE OR CAPACITY	<p>Air leak in suction line; end of suction line not submerged; foot valve blocked or jammed; insufficient liquid in sump or tank.</p> <p>Shaft seal leaking; gaskets, O-rings worn.</p> <p>Relief valve pressure set too low.</p> <p>Suction or discharge lines blocked; suction or discharge valves closed.</p> <p>Pump speed too slow.</p> <p>Pump "starving" or liquid vaporizing in suction line.</p> <p>Rotating parts worn or damaged; improper end clearance.</p>	<p>Check and correct as required.</p> <p>Check vacuum gauge; disassemble pump and replace faulty parts.</p> <p>Readjust.</p> <p>Check strainer, valves and piping.</p> <p>Check driver speed; check belts/couplings.</p> <p>Increase suction pipe size or reduce length; position pump below liquid level.</p> <p>Replace defective parts; see SETTING END CLEARANCE in Maintenance And Repair, Section E.</p>
PUMP REQUIRES TOO MUCH POWER	<p>Insufficient end clearances.</p> <p>Pump speed too high.</p> <p>Internal parts worn.</p> <p>Discharge line undersized and/or too long.</p>	<p>Readjust clearance; see SETTING END CLEARANCE in Maintenance and Repair, Section E.</p> <p>Reduce driver output.</p> <p>Disassemble pump and inspect.</p> <p>Increase size, decrease length.</p>

TROUBLESHOOTING CHART (Cont.)

TROUBLE	POSSIBLE CAUSE	PROBABLE REMEDY
PUMP REQUIRES TOO MUCH POWER (Cont.)	<p>Pump and/or drive mounting not secure; drive misaligned.</p> <p>Power source undersized.</p> <p>Lubrication required.</p> <p>Liquid in pump solidified.</p> <p>Insufficient internal clearances.</p>	<p>Tighten mounting hardware; realign drive.</p> <p>Check power requirements for application; resize as required.</p> <p>Add lubricant, as needed.</p> <p>Clear or heat.</p> <p>Consult factory.</p>
EXCESSIVE NOISE OR VIBRATION	<p>Pump and/or piping not secure; drive misaligned.</p> <p>Pumping entrained air.</p> <p>Pump "starving" or liquid vaporizing in suction line.</p> <p>Relief valve chatter.</p> <p>Rotating parts worn or damaged; improper end clearance.</p> <p>Pump operating outside designed operating range.</p> <p>Lubrication required.</p>	<p>Anchor base or piping, realign drive.</p> <p>Check liquid level.</p> <p>Increase suction pipe size or reduce length; position pump below liquid level.</p> <p>Increase pressure setting.</p> <p>Replace defective parts; check end clearance.</p> <p>Check discharge head and flow; adjust as required to meet performance specifications.</p> <p>Add lubricant, as needed.</p>
EXCESSIVE WEAR	<p>Corrosive liquid.</p> <p>Abrasive liquid.</p> <p>Contaminated liquid.</p> <p>Exceeding operating limits.</p> <p>Insufficient end clearance.</p> <p>Pump running dry.</p> <p>Pump and/or drive mounting not secure; drive misaligned; piping incorrectly installed.</p> <p>Insufficient lubrication.</p>	<p>Check local distributor or factory for parts compatibility with liquid; check liquid for contamination.</p> <p>Consult factory.</p> <p>Check liquid source; install strainer.</p> <p>Check performance data in Pump Specifications Bulletin.</p> <p>See SETTING END CLEARANCE in Maintenance And Repair, Section E.</p> <p>Add liquid to prime (See Operation, Section C); check liquid flow.</p> <p>Tighten mounting hardware; realign drive; check piping.</p> <p>Add lubrication and maintain at proper level.</p>

PREVENTIVE MAINTENANCE

Since pump applications are seldom identical, and pump wear is directly affected by such things as the abrasive qualities, pressure and temperature of the liquid being pumped, this section is intended only to provide general recommendations and practices for preventive maintenance. Regardless of the application however, following a routine preventive maintenance schedule will help assure trouble-free performance and long life from your Gorman-Rupp rotary gear pump. For specific questions concerning your application, contact your Gorman-Rupp distributor or the Gorman-Rupp Company.

Record keeping is an essential component of a good preventive maintenance program. The appearance of wearing parts should be documented at each inspection for later comparison. Also, if records indicate that a certain part (such as the seal) fails at the same duty cycle, this part can be checked and replaced before failure occurs.

Because of the tight tolerances within your rotary gear pump, wear between rotating parts is normal and expected. For new applications, a first inspec-

tion at 250 hours will give insight into the wear rate for your particular application. Subsequent inspections should be performed at regular intervals of 2000 hours. Critical applications should be inspected more frequently.

Check the thrust washer, idler bushing, idler pin, idler assembly, shaft bushing and rotor/shaft assembly at each inspection. Wear patterns should be uniform, without evidence of deep or irregular grooves.

For packing pumps, periodic adjustment of the packing is required to keep leakage to a minimum (see the adjustment procedure described under **Leakage in Operation, Section C**). Do not over-tighten. Replace the packing if leakage cannot be reduced by a slight adjustment.

After extended service, adjustment of the clearance between the rotor and the head will normally improve performance (see the adjustment procedure in **Maintenance And Repair, Section E**).

If the pump is to be removed from service for repair, be sure to protect the internal components from rusting while the pump is disassembled and after reassembly if not immediately placed back into service.

MAINTENANCE AND REPAIR – SECTION E

MAINTENANCE AND REPAIR OF THE WEARING PARTS OF THE PUMP WILL MAINTAIN PEAK OPERATING PERFORMANCE.

Pump Model

Your pump model number and serial number are shown on the **Parts List**, furnished as a separate document with this manual.

Below the pump model number on the **Parts List**, is a grouping of several alpha-numeric codes. This code identifies the optional features of the pump. **Be sure** to include this grouping, along with the model number and serial number, when ordering parts.

The sectional views cover disassembly and reassembly for the pump models shown below. Refer to the **Parts List** for your specific pump model.

The Following Pumps Are Covered By This Manual.



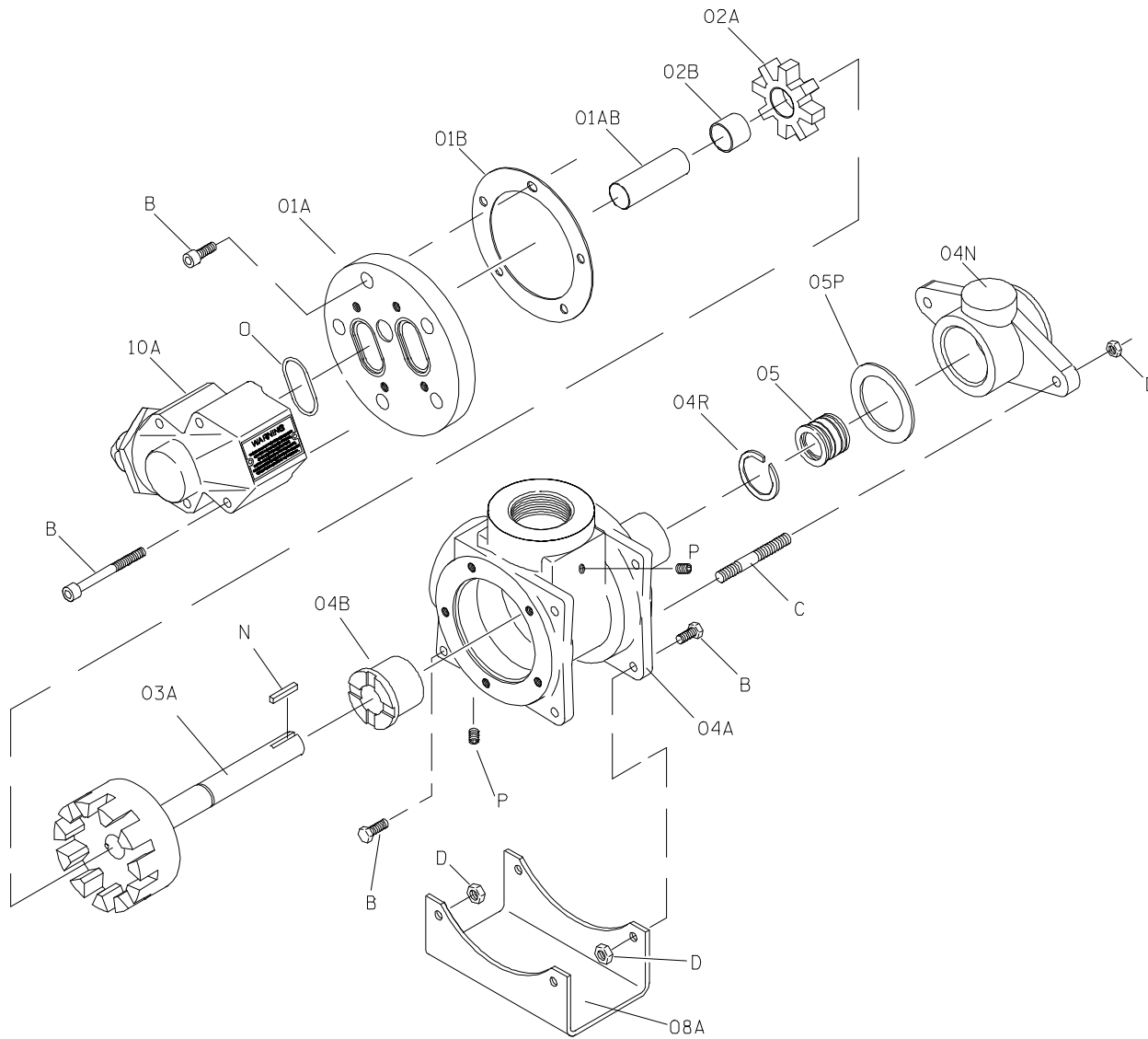

46166-311

Shown: Standard Model With 90° Ports, Foot Bracket And Head-Mounted Relief Valve. Also Available With 180° Ports And/Or Head Jacket, Backhead Jacket And Housing-Mounted Relief Valve. Coverplate Kit Replaces Either Relief Valve When Not Used.

NOTE: Refer to **Seal Appendix, Section F** for details of the seal assembly and related components.

Figure E-1. Typical GMS D, G, J And N Pump Models

PARTS KEY FOR FIGURE E-1

Note: Item numbers cross reference to specific part numbers on the separate **Parts List**.

ITEM NO.	PART NAME	ITEM NO.	PART NAME
01	HEAD KIT	08	FOOT BRACKET KIT
01A	–HEAD ASSEMBLY	08A	–FOOT BRACKET
01AA	–HEAD	B	–CAPSCREW
01AB *	–IDLER PIN	D	–NUT
P	–PIPE PLUG		
01B *	–GASKET	10	RELIEF VALVE KIT
B	–CAPSCREW	10A	–RELIEF VALVE ASSEMBLY
		10AA	–VALVE BODY
02	IDLER ASSEMBLY	10AB	–WARNING PLATE
02A	–IDLER	BM	–DRIVE SCREW
02B *	–BUSHING	B	–CAPSCREW
		O *	–O-RING
03	ROTOR/SHAFT KIT		NOT SHOWN:
03A	–ROTOR/SHAFT ASSEMBLY	11	HEAD COVERPLATE KIT
N	–SHAFT KEY	11A	–COVERPLATE ASSEMBLY
		11AA	–COVERPLATE
04	HOUSING ASSEMBLY	11AC	–WARNING PLATE
04A	–HOUSING	BM	–DRIVE SCREW
04B	–FLANGED SHAFT BUSHING	P	–PIPE PLUG
04N	–GLAND	K	–WASHER
04R	–RETAINING RING	B	–CAPSCREW
C	–STUD	O *	–O-RING
D	–NUT		
P	–PIPE PLUG		
05 *	SEAL & RELATED COMPONENTS (SEE SECTION F)	12	NAMEPLATE KIT
05P *	–GLAND GASKET	12A	–NAMEPLATE
		BM	–DRIVE SCREW
	* INDICATES PARTS RECOMMENDED FOR STOCK		
NOTE:	Refer to O-Ring Appendix, Section G for O-ring identification and location.		

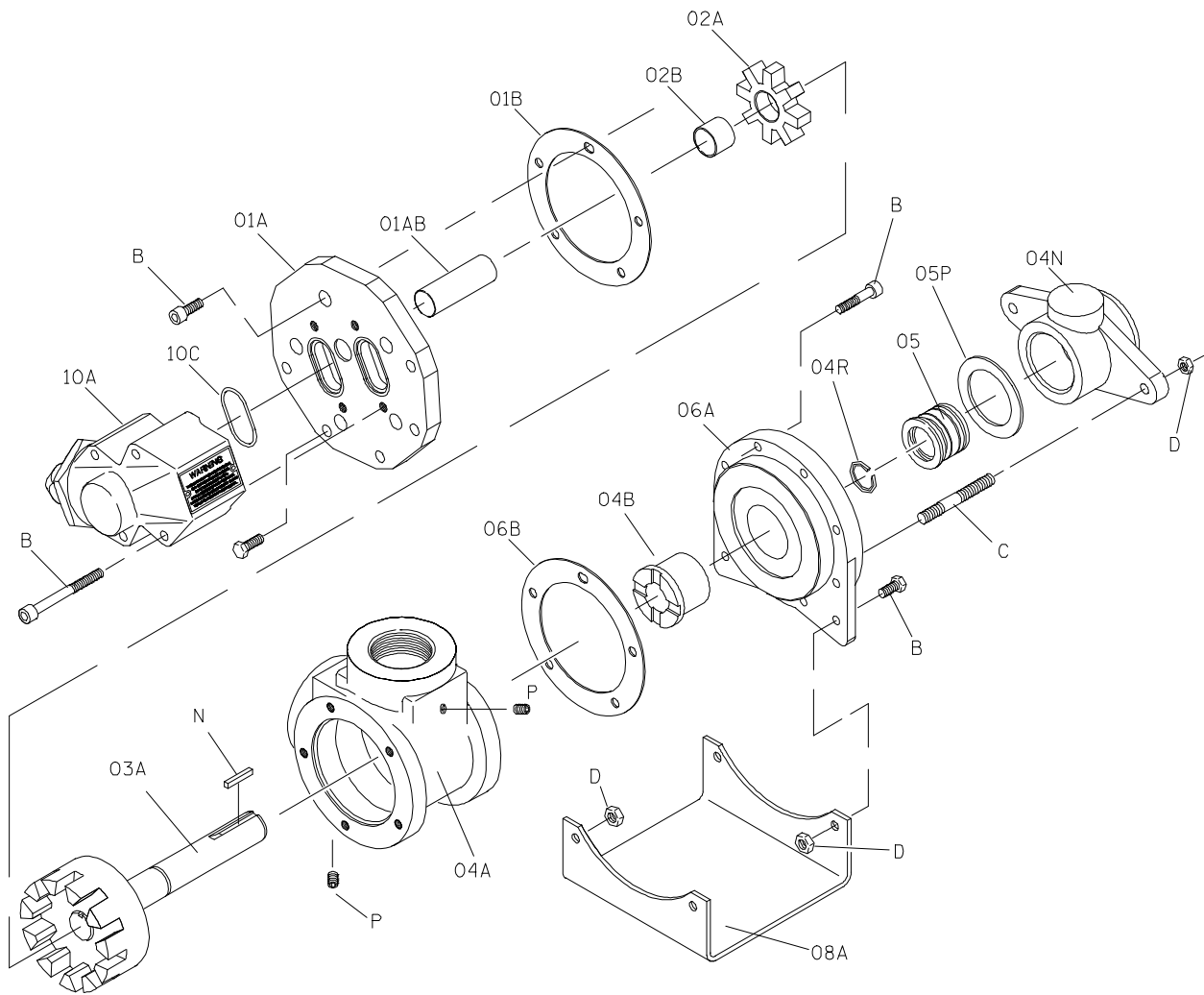

46166-313

Shown: Standard Model With 90° Ports, Foot Bracket And Head-Mounted Relief Valve. Also Available With 180° Ports And/Or Head Jacket, Backhead Jacket And Housing-Mounted Relief Valve. Coverplate Kit Replaces Either Relief Valve When Not Used.

NOTE: Refer to **Seal Appendix, Section F** for details of the seal assembly and related components.

Figure E-2. Typical GMS R Pump Model

PARTS KEY FOR FIGURE E-2

Note: Item numbers cross reference to specific part numbers on the separate **Parts List**.

ITEM NO.	PART NAME	ITEM NO.	PART NAME
01	HEAD KIT	06	BACKHEAD ASSEMBLY
01A	–HEAD ASSEMBLY	06A	–BACKHEAD
01AA	–HEAD	06B	–BACKHEAD GASKET
01AB *	–IDLER PIN		
P	–PIPE PLUG	08	FOOT BRACKET KIT
01B *	–GASKET	08A	–FOOT BRACKET
B	–CAPSCREW	B	–CAPSCREW
		D	–NUT
02	IDLER ASSEMBLY	10	RELIEF VALVE KIT
02A	–IDLER	10A	–RELIEF VALVE ASSEMBLY
02B *	–BUSHING	10AA	–VALVE BODY
		10AB	–WARNING PLATE
03	ROTOR/SHAFT KIT	BM	–DRIVE SCREW
03A	–ROTOR/SHAFT ASSEMBLY	B	–CAPSCREW
N	–SHAFT KEY	O *	–O-RING
			NOT SHOWN:
04	HOUSING ASSEMBLY	11	HEAD COVERPLATE KIT
04A	–HOUSING	11A	–COVERPLATE ASSEMBLY
04B	–FLANGED SHAFT BUSHING	11AA	–COVERPLATE
04N	–GLAND	11AC	–WARNING PLATE
04R	–RETAINING RING	BM	–DRIVE SCREW
C	–STUD	P	–PIPE PLUG
D	–NUT	K	–WASHER
P	–PIPE PLUG	B	–CAPSCREW
		O *	–O-RING
05 *	SEAL & RELATED COMPONENTS (SEE SECTION F)	12	NAMEPLATE KIT
		12A	–NAMEPLATE
05P *	GLAND GASKET	BM	–DRIVE SCREW
	* INDICATES PARTS RECOMMENDED FOR STOCK		
NOTE:	Refer to O-Ring Appendix, Section G for O-ring identification and location.		

PUMP DISASSEMBLY AND REASSEMBLY

Review all **SAFETY** information in Section A.

Follow the instructions on all tags, labels and decals attached to the pump.

This pump requires little service due to its rugged, minimum-maintenance design. However, if it becomes necessary to inspect or replace the wearing parts, follow these instructions which, unless otherwise specified, are keyed to the sectional views (see Figures E-1 and E-2) and the accompanying parts keys. Refer to the separate parts list accompanying your pump for part numbers.

In the following text, minor headings are followed by a number in parenthesis. This number represents the assembly for the item being discussed as identified in Figures E-1 and E-2.

Before attempting to service the pump, disconnect the power source to ensure that it will remain inoperative. Remove the hardware securing the pump to the power source, and separate the power source and pump assembly. Retain all connection parts such as shaft keys, etc.

Close all valves in the suction and discharge lines. Disconnect the suction and discharge hose/piping.

For power source disassembly and repair, consult the literature supplied with the power source, or contact your local power source representative.



This manual will alert personnel to known procedures which require special attention, to those which could damage equipment, and to those which could be dangerous to personnel. However, this manual cannot possibly provide detailed instructions and precautions for each specific application or for every situation that might occur during maintenance of the unit. Therefore, it is the responsibility of the owner, installer

and/or maintenance personnel to ensure that applications and/or maintenance procedures not addressed in this manual are performed only after establishing that neither personal safety nor pump integrity are compromised by such applications or procedures.



Do not attempt to service the pump unless all power to the power source has been disconnected; otherwise, serious personal injury or death could result.



Use **Only Genuine Gorman-Rupp** replacement parts. Failure to do so may create a hazard and damage the pump or diminish optimal pump performance. Any such hazard, damage or diminished performance is not covered by the warranty.

NOTE

When appropriate recycling facilities are available, the user should recycle components and fluids when doing any routine maintenance / repairs and also at the end of the pump's useful life. All other components and fluids shall be disposed of according to all applicable codes and regulations.

PUMP DISASSEMBLY



This pump may be used to handle liquids which may cause serious illness or injury through direct exposure or emitted fumes. Wear protective clothing, such as rubber gloves, face mask and rubber apron, as necessary, before disconnecting or servicing the pump or piping.

In the instructions which follow the **FRONT** is the head assembly end of the pump and the **REAR** is the drive (or backhead) end of the pump.

NOTE

It is strongly recommended that gaskets and O-rings be replaced whenever the pump is reassembled.

Preparing for Disassembly

The pump should be removed from the system piping and drained for servicing. Close all valves in the suction and discharge lines to isolate the pump. Position drain pans and/or absorbant material under and around the pump suction and discharge ports. Disconnect the suction and discharge hose/piping.

Remove the hardware securing the pump to the power source and separate the power source and pump assembly. Retain all connection parts such as shaft keys, etc.

Use a hoist and sling with sufficient capacity to position the pump in a suitably sized drain pan or surround the pump with absorbant material. Some pumps are equipped with drain plugs in the head and backhead. Remove the plug(s) and drain the pump before proceeding with disassembly.

Pressure Relief Valve (10)

If the pump is equipped with a pressure relief valve (10A), it can be mounted on either the head assembly (01A) or the housing assembly (04). Some models are equipped with one of each. Take note as to the direction in which the relief valve is mounted. To remove either style, remove the cap-screws (B) securing the relief valve to the pump. The O-rings (10C) may remain in the head (01A) or in the housing (04A). Remove and discard the O-rings. For relief valve maintenance, see **RELIEF VALVE DISASSEMBLY** followed by **RELIEF VALVE REASSEMBLY** at the end of this section.

Foot Bracket Kit (08, R Size Only)

Remove the hardware (B and D) securing the foot bracket (08A) to the head (01A) and backhead (06A).

Head/Idler Kit (01/02)

Disengage the hardware (B) and separate the head jacket (if so equipped) and/or head assembly (01A) from the housing (04A).



Use caution to prevent the idler assembly from dropping off the idler pin; the idler may be damaged if it falls on a hard surface.

Pull the head assembly (01A) from the housing assembly (04). Take care not to let the idler assembly (02) slide off the idler pin (01AB). Remove and discard the gasket (01B).



Use caution when handling the idler (02A) and the rotor shaft assembly (03A). These parts have sharp edges which will grow sharper with use.

NOTE

The idler bushing (02B) may be damaged during removal. Do not remove the idler bushing unless replacement is required.

Remove the assembled idler (02) and bushing (02B) from the head assembly. Inspect the idler bushing for excessive wear or scoring. If replacement is required, use an arbor (or hydraulic) press and a suitably sized dowel to remove the idler bushing (02B) from the idler (02A).

To remove the idler pin (01AB), lay the head assembly (01A) on an arbor (or hydraulic) press with the idler pin (01AB) facing down and press the idler pin (01AB) from the head (01AA).

Gland Removal (04N)

NOTE

*Part of the seal assembly (5) will be removed with the gland (04N). Check the **Parts List** furnished with your pump to identify the seal, refer to **Seal Appendix, Section F** for removal of the seal and re-*

lated components, then proceed as follows with pump disassembly.

Remove the nuts (D) and slide the stuffing box (04N) off the rotor shaft assembly (03A). Remove the stuffing box gasket (05P).

Remove the seal assembly (05) and related components as described in **Seal Appendix, Section F**.

Backhead Removal (06, R Size Only)

(Figure E-2 Only)

Disengage the screws (B) securing the backhead (06A) to the housing assembly (04) and separate the assemblies. Remove and discard the gasket (06B).

NOTE

The shaft bushing (04B) may be damaged during removal. Do not remove the shaft bushing unless replacement is required.

If your pump is equipped with a graphite or silicon carbide shaft bushing (04B), the old bushing can be removed by breaking it into pieces using a hammer and chisel. **Use caution** not to damage the I.D. of the backhead.

If your pump is equipped with a bronze shaft bushing, the bushing must be machined out of the backhead. **Use caution** not to damage the I.D. of the backhead.

Rotor/Shaft Removal (03)

Slide the rotor/shaft assembly (03A) out of the housing (04A). Due to close machine tolerances and assembly practices, the rotor/shaft is available only as an assembly. Further disassembly is not required.

Seal Removal (05)

The seal assembly (05) is available in a variety of configurations. Check the **Parts List** furnished with your pump to identify the seal, then refer to **Seal Appendix, Section F**, for removal of the seal and related components.

Housing Assembly (04, D, G, J, N Sizes Only)

(Figure E-1 Only)

NOTE

The shaft bushing (04B) may be damaged during removal. Do not remove the shaft bushing unless replacement is required.

If your pump is equipped with a graphite or silicon carbide shaft bushing (04B), the old bushing can be removed by breaking it into pieces using a hammer and chisel. **Use caution** not to damage the I.D. of the housing.

If your pump is equipped with a bronze shaft bushing, the bushing must be machined out of the housing. **Use caution** not to damage the I.D. of the housing.

PUMP REASSEMBLY



Use caution when handling the idler (02A) and the rotor shaft assembly (03A). These parts have sharp edges which will grow sharper with use.

Cleaning and Inspection



Most cleaning solvents are toxic and flammable. Use them only in a well ventilated area free from flame, sparks, and excessive heat. Read and follow all precautions printed on solvent containers.

Clean and inspect the pump parts (except the seal assembly) with a cloth soaked in fresh cleaning solvent. Inspect all parts for excessive wear or for any nicks or burrs. Remove nicks or burrs using emery cloth or a fine file. Replace any parts that are badly worn or damaged.

Clean and inspect the seal assembly as indicated in the appropriate section of the **Seal Appendix, Section F**.

Bushing Preparation

When replacing bushings, lightly oil the O.D. of the replacement bushing before installation.



Be very careful when installing graphite bushings. Graphite is extremely brittle and will crack if improperly installed. Use a press to install the bushing with one continuous motion until the bushing is fully seated. Stopping in mid-stroke will cause the bushing to crack. After installation, check the bushing for cracks.

NOTE

*When installing **high temperature graphite bushings**, heat the part that receives the bushing to 500°F and place the bushing in a freezer for at least one hour. This will allow easy installation without breakage and provide a tight shrink fit after cooling.*

Housing Assembly (04)

Clean and inspect the housing (04A) with a cloth soaked in fresh cleaning solvent. Replace the housing if badly worn or damaged.



Most cleaning solvents are toxic and flammable. Use them only in a well ventilated area free from flame, sparks, and excessive heat. Read and follow all precautions printed on solvent containers.

When installing a replacement shaft bushing (04), position the housing on the bed of an arbor (or hydraulic) press with the drive end facing down. Press the bushing into the housing until fully seated against the bore shoulder.

Backhead (06)

(Figure E-2 Only)

Clean and inspect the backhead (06) with a cloth soaked in fresh cleaning solvent. Replace the backhead if badly worn or damaged.



Most cleaning solvents are toxic and flammable. Use them only in a well ventilated area free from flame, sparks, and excessive heat. Read and follow all precautions printed on solvent containers.

When installing a replacement shaft bushing (04), position the backhead on the bed of an arbor (or hydraulic) press with the drive end facing down. Press the bushing into the backhead until fully seated against the bore shoulder.



Be very careful when installing graphite bushings. Graphite is extremely brittle and will crack if improperly installed. Use a press to install the bushing with one continuous motion until the bushing is fully seated. Stopping in mid-stroke will cause the bushing to crack. After installation, check the bushing for cracks.

NOTE

*When installing **high temperature graphite bushings**, heat the part that receives the bushing to 500°F and place the bushing in a freezer for at least one hour. This will allow easy installation without breakage and provide a tight shrink fit after cooling.*

Install a new gasket (06B) and secure the backhead to the housing (04A) with the previously removed capscrews (B).

Rotor/Shaft Assembly (03)

Inspect the rotor/shaft assembly (03A) for excessive wear, scoring or scratches along the shaft sealing surface. If replacement is required, the

shaft and rotor must be replaced as an assembly. Small scratches can be dressed with a fine file or emery cloth. Replace the rotor/shaft assembly or any other parts if wear or damage is extensive.

Carefully slide the rotor/shaft assembly into the housing. **Use caution** not to scratch the I.D. of the housing bushings (04B).

Head/Idler Kit (01/02)

If the idler pin (01AB) was removed, apply Loctite Pipe Sealant with Teflon No. 565 or equivalent compound to the I.D. of the idler pin bore in the head (01A). Position the pin in the head with the chamfered side toward the head and the milled flat side facing the crescent. (If the pin is stepped, position it with the large chamfered end toward the head.) Use an arbor (or hydraulic) press to press the pin into the head until it bottoms out.

NOTE

When properly installed, the pin will be positioned 0.010 inch below the surface of the crescent.

Lightly oil the I.D. of the idler (02A), and use an arbor (or hydraulic) press to install the idler bushing (02B) in the idler. The bushing should be centered at both ends of the idler.

Place the head (01A) on a flat surface. Lightly oil the idler bushing (02B) and pin (01AB); install the idler assembly (02) on the pin. Spin the idler to make certain that it moves freely on the pin.

See **SETTING END CLEARANCE** and calculate the number and thickness of gaskets (01B) required for your application and hydraulic pump size. Position the gasket(s) against the head, and slide the head into the housing assembly. Rotate the head (01A) until the groove in the head matches the groove in the housing. Secure the head to the housing with the capscrews (B).

Seal Installation (05)

The seal assembly (05) is available in a variety of configurations. Check the **Parts List** furnished with your pump to identify the seal, then refer to **Seal**

Appendix, Section F, for installation of the seal and related components.

Gland Installation (04N)

NOTE

*The seal assembly (5) must be installed with the gland. Check the **Parts List** furnished with your pump to identify the seal, refer to **Seal Appendix, Section F** for installation of the seal and related components, then proceed as follows with pump reassembly.*

Install the gland gasket (05P). With the seal and related components installed, slide the gland (04N) over the rotor shaft assembly (03A) and secure it to the housing (or backhead) with the nuts (D).

Foot Bracket Kit (08, R Size Only)

Secure the foot bracket (08A) to the head (01A) and backhead assembly (06A, Figure 2) with the hardware (B and D).

SETTING END CLEARANCE

(Figures E-1 and E-4)

The end clearance between the head (01AA) and the face of the rotor (03A) should be checked and adjusted as required as part of a regular preventive maintenance schedule, when performance drops or the pump is disassembled.

NOTE

*The end clearance is established **without** the head gasket set (01B) in place.*

Slide the head assembly into the housing assembly. Rotate the head (01AA) until the groove in the head matches the groove in the housing. Secure the head to the housing with the capscrews (B). The head **must** be drawn completely tight against the housing to establish the correct end clearance.

Use a feeler gauge to measure the clearance between the front of the housing assembly and the back of the head as shown in Figure E-4.

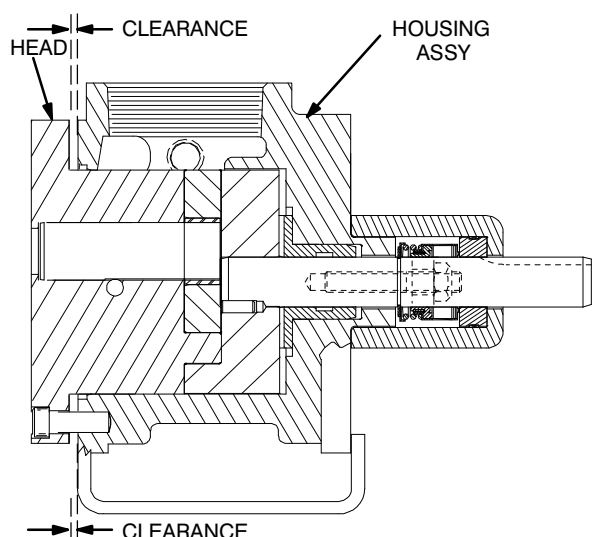

Figure E-4. End Clearance Adjustment

See Tables E-1 or E-2 to determine the gasket(s) (01B) required for the viscosity and temperature of the liquid being pumped. Remove the head from the housing assembly and install the gasket(s). Reinstall the head on the housing assembly (04) and secure with the capscrews (B).

NOTE

The gasket set (01B) includes (2) 0.006 inch gaskets and (2) 0.015 inch gaskets and will accommodate all standard clearances. If additional clearance is required, order two kits.

Feeler Gauge Reading	2500 SSU 225°F (107°C)	250,000 SSU 300°F (149°C)
0.000–0.002	(1) 0.015 (1) 0.006	(2) 0.015
0.003–0.006	(2) 0.015	(2) 0.015 (1) 0.006
0.007–0.010	(2) 0.015 (1) 0.006	(2) 0.015 (2) 0.006

Notes:
Viscosities and Temperatures are Maximums.
Gasket Quantities Shown in Parenthesis.
For Special Applications, Consult Your Local Gorman-Rupp Distributor or the Factory.

**Table E-1. End Clearance Gaskets
(Based on Liquid Viscosity)**

Feeler Gauge Reading	Std Rotor Trims	35C, 35D, 35J, 35L & 35M Rotor Trims
0.000–0.002	(1) 0.015 (1) 0.006	(2) 0.015
0.003–0.006	(2) 0.015	(2) 0.015 (1) 0.006
0.007–0.010	(2) 0.015 (1) 0.006	(2) 0.015 (2) 0.006
0.011–0.014	(2) 0.015 (2) 0.006	(3) 0.015 (1) 0.006
0.015–0.018	(3) 0.015 (2) 0.006	(3) 0.015 (2) 0.006

Notes:
Consult Pump Parts List For Rotor Trim Code.
For Rotor Trim Codes Not Listed or for Special Applications, Consult Your Local Gorman-Rupp Distributor or the Factory.

**Table E-2. End Clearance Gaskets
(Based on Rotor Trim Code)**

RELIEF VALVE DISASSEMBLY

(Figure E-6)

NOTE

If the relief valve is low pressure, it will have one internal spring (10AE). If the relief valve is high pressure, it will have two internal springs (10AE and 10AF).

Unscrew the cap (10AN) from the bonnet (10AK) and remove the gasket (10AP). Back off the adjustment capscrew (10AM) to relieve pressure on the spring(s) (10AE and/or 10AF).

Unscrew the bonnet from the valve body (10AA). Remove the valve (10AD) and spring(s) (10AE and/or 10AF). The spring guide (10AH) is an O-ring fit in the bonnet. Remove and discard the O-rings.

If the warning plate (10AB) must be replaced, remove the drive screws (BM), and remove the plate.

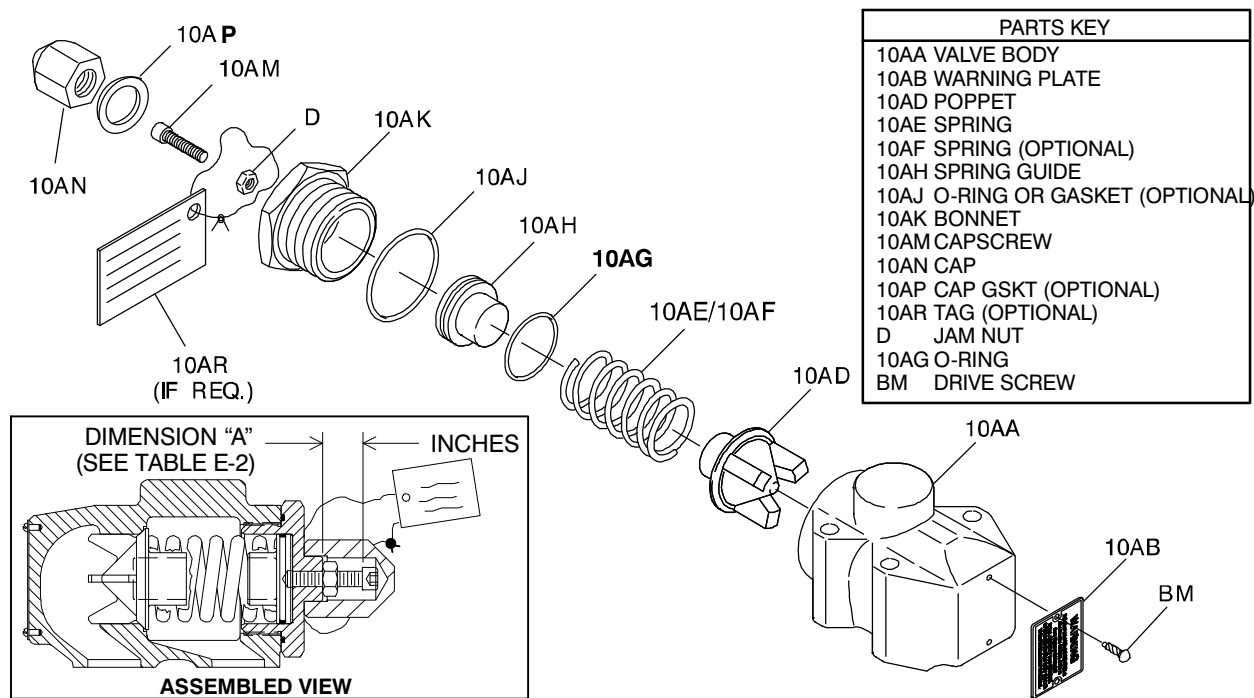

Figure E-5. Pressure Relief Valve Assembly

RELIEF VALVE REASSEMBLY

(Figure E-5)



Do not return the pump to service without the warning plate (10AB) installed. Failure to observe the warning on the plate could result in destruction of the pump, and injury or death to personnel.

Inspect the components for wear, grooves, or other damage that might cause leakage. If any components are worn, replace the defective parts.

If removed, attach the warning plate (10AB) to the valve body (10AA) using the drive screws (BM).

If used, lightly oil the O-ring (10AJ) and install it in the groove on the bonnet (10AK).

Lightly oil the O-ring (10AG) and install it in the groove on the spring guide (10AH). Start the large end of the spring guide into the bonnet (10AK), and push the guide in until it bottoms out.

Insert the valve (10AD), finned end first, into the valve body (10AA). Install the spring(s) (10AE and/or 10AF). Make certain that the spring (10AE) fits **over** the spring guide (10AH), and the optional spring (10AF) fits **into** the guide, and thread the bonnet into the valve body.

Install the jam nut (D) on the adjustment capscrew (10AM), and thread the capscrew into the bonnet until the desired height "A" is reached. See Table E-3 and adjust the capscrew (10AM) to the proper "A" dimension for desired cracking pressure.



Never operate the pump without the adjusting screw jam nut in place. Otherwise, the relief valve spring(s) can be compressed too far for the valve to open. If the valve does not open, excessive pressure can develop, causing damage to the pump and possible injury to personnel.

Refer to the separate Parts List accompanying your pump, and determine the specific hydraulic size (D, G, J, etc.).

PUMP HYDRAULIC SIZE	SINGLE SPRING OPTION CODE	CRACKING PRESSURE (PSI)	DIMENSION "A" (INCHES) (Fig. E-7)	DOUBLE SPRING OPTION CODE	CRACKING PRESSURE (PSI)	DIMENSION "A" (INCHES) (Fig. E-7)
D & G	STD	50 MIN.	.60 FULLY OUT	25A 25E 25H 25K	100 MIN.	.60 FULLY OUT
		* 75	.47		125	.51
	25D	100	.33		* 150	.42
	25G	130 MAX.	.16 FULLY IN		175	.33
	25J				200	.23
					225 MAX.	.16 FULLY IN
J & N	STD	30 MIN.	1.17 FULLY OUT	25A 25E 25H 25K	50 MIN.	1.17 FULLY OUT
		50	.88		100	.93
	* 75	.57	125		.83	
	25D	95 MAX.	.31 FULLY IN		* 150	.72
	25G				175	.61
	25J				200	.50
R	STD	55 MIN.	1.23 FULLY OUT	25A 25H 25K	105 MIN.	1.23 FULLY OUT
		75	.89		125	.90
	100	.51	* 150		.70	
	25D	110 MAX.	.37 FULLY IN		175	.55
	25G				190 MAX.	.37 FULLY IN
	25J	*				

Table E-3 . Cracking (Valve Opening) Settings (* Denotes Factory Setting)

After adjustment, tighten the jam nut (D) flush against the bonnet.

Place the optional warning tag (10AR) between the bonnet and the cap (10AN). Install the cap, and tighten until fully seated against the bonnet.

Relief Valve (10) Installation



If pump rotation is changed, the position of the head-mounted pressure relief valve (10A) must also be changed. The relief valve must **always** be mounted so the cap

on the relief valve is positioned toward the suction port.

Lubricate and install the O-ring(s) (10C) on the housing assembly (04A) or the head assembly (01A). Secure the relief valve (10A) with the capscrews (B).



Do not return the pump to service without the warning plate (10AB) installed. Failure to observe the warning on the plate could result in destruction of the pump, and injury or death to personnel.

If the warning plate (10AB) has been removed, secure it with the drive screws (BM).

SEAL APPENDIX – SECTION F

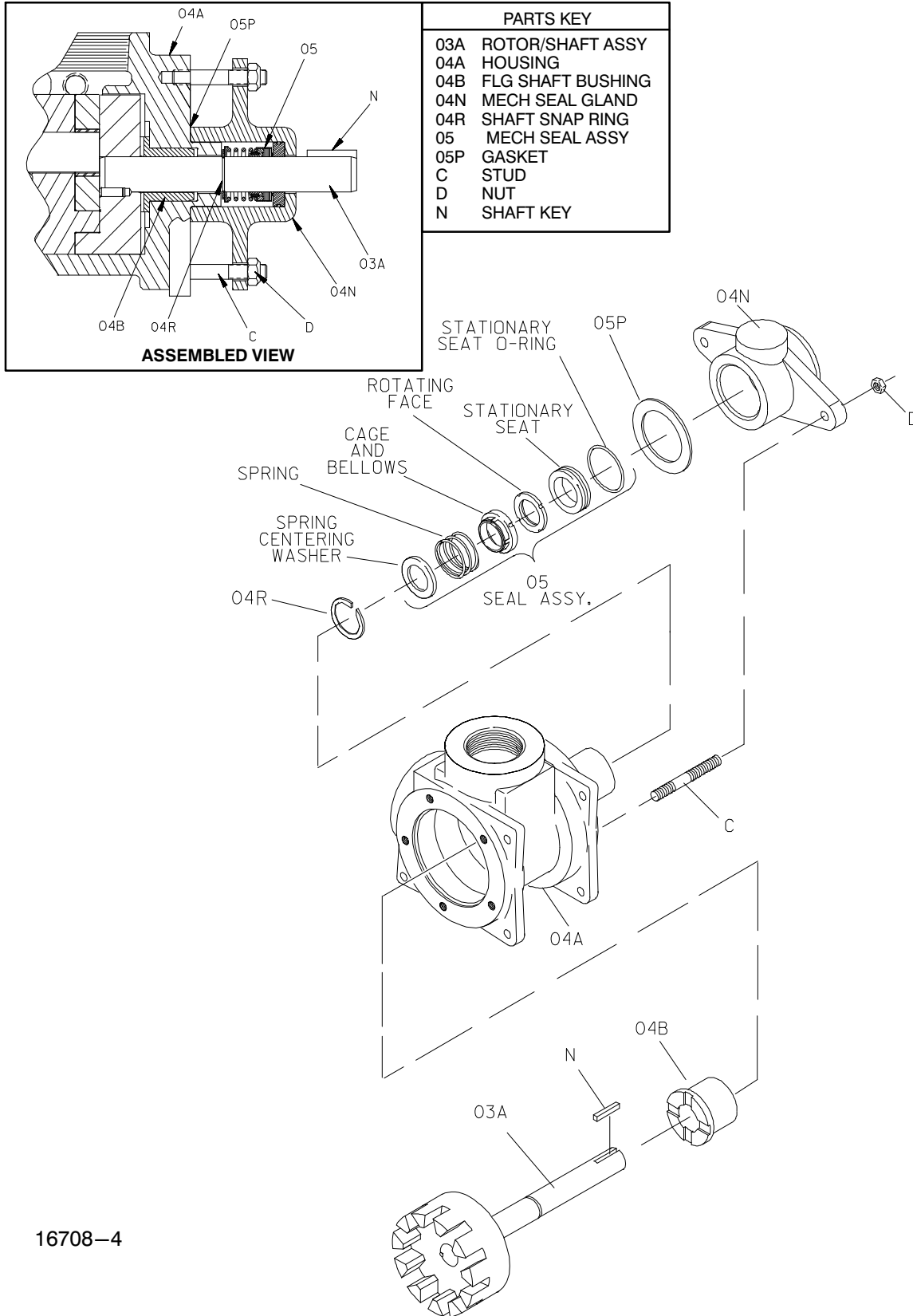

16708-4

Figure F-1. Standard Friction Drive And Optional 60A And 61J Mechanical Seals

Seal Removal

(Figures E-1 and F-1)

Separate the pump and driver and remove the shaft key (N).

Remove the nuts (D) and slide the gland (04N) and stationary seal components off the shaft as a unit. Press the seal stationary seat and O-ring out of the gland from the back side. Remove the gasket (05P).

Apply oil to the shaft and work it up under the rubber seal bellows. Slide the rotating portion of the seal off the shaft. Remove the seal spring and spring centering washer.

It is not necessary to remove the shaft snap ring (04R) unless the rotor and shaft assembly (03A) is to be removed. Use snap ring pliers to remove the snap ring if required.

Continue as required with **PUMP DISASSEMBLY**.

Seal Installation

(Figures E-1 and F-1)

See **PUMP REASSEMBLY**, and reassemble the pump up to the rotor and shaft assembly (03A).

Clean the seal cavity and shaft with a cloth soaked in fresh cleaning solvent.



Most cleaning solvents are toxic and flammable. Use them only in a well ventilated area free from flame, sparks, and excessive heat. Read and follow all precautions printed on solvent containers.

The seal is not normally reused because wear patterns on the finished faces cannot be realigned during reassembly. This could result in premature failure. If necessary to reuse an old seal in an emer-

gency, **carefully** wash all metallic parts in fresh cleaning solvent and allow to dry thoroughly.

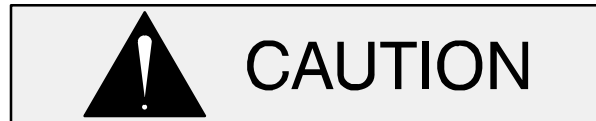

Seal components **must** be kept clean. Handle seal parts with extreme caution to prevent damage. Use care not to contaminate the precision-finished faces; even fingerprints on the faces can shorten seal life. If necessary to clean the faces, use a clean cloth and wipe in a circular pattern.

Inspect the seal components for wear, scoring, grooves, and other damage that might cause leakage. If any components are worn, replace the complete seal; **never mix old and new seal parts**.

If a replacement seal is being used, unwrap the mechanical seal components. Check that the seal faces are clean, undamaged and free of any foreign matter.

Lubricate the stationary element O-ring with light oil. Position the stationary element in the gland (04N) with the sealing face up. Cover the sealing face with a clean tissue. Use a push tube (I.D. slightly larger than the shaft diameter) to press the stationary element into the gland until fully seated.

If removed, install the shaft snap ring (04R) in the groove in the rotor/shaft assembly (03A). Lightly oil the shaft of the rotor/shaft assembly. Slide the spring centering washer and spring onto the shaft until fully seated against the snap ring. Position the rotating portion of the seal on the shaft with the sealing face toward the drive end of the shaft. Place a clean tissue over the sealing face of this rotating subassembly and slide it onto the shaft until the seal retainer seats squarely against the spring.

Install a new gasket (05P). Carefully slide the assembled gland and stationary seal components onto the shaft until the sealing faces contact. Install the nuts (D) and tighten them alternately until the gland is fully seated.

Reinstall the shaft key (N) and reconnect the driver.

SEAL APPENDIX – SECTION F

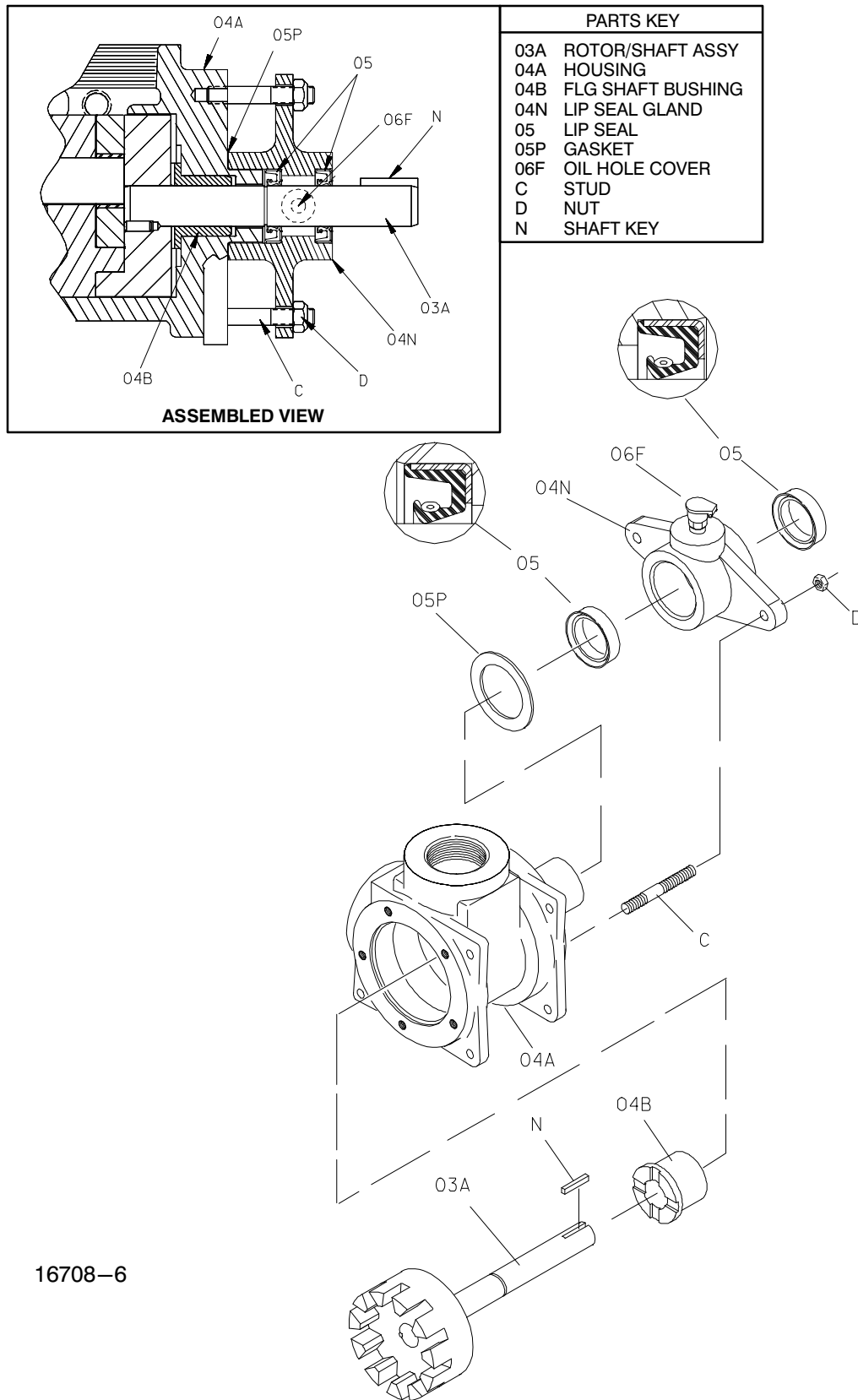

Figure F-2. Optional 65A Lip Seal

Seal Removal

(Figures E-1 and F-2)

Separate the pump and driver and remove the shaft key (N).

There are no provisions for draining oil from the reservoir between the two oil seals (05). Place a drip pan under the drive end of the pump and thoroughly clean up any spillage that may occur.

Remove the nuts (D) and slide the gland (04N) and lip seals (05) off the shaft as a unit. Remove the gasket (05P).

Use a dowel or other suitable tool to press the lip seals out of the gland.

It is not necessary to remove the shaft snap ring (05D) unless the rotor and shaft assembly (03A) is to be removed. Use snap ring pliers to remove the snap ring if required.

Continue as required with **PUMP DISASSEMBLY**.

Seal Installation

(Figures E-1 and F-2)

See **PUMP REASSEMBLY**, and reassemble the pump up to the rotor and shaft assembly (03A).

Clean the seal cavity and shaft with a cloth soaked in fresh cleaning solvent.



Most cleaning solvents are toxic and flammable. Use them only in a well ventilated area free from flame, sparks, and excessive heat. Read and follow all precautions printed on solvent containers.

Lightly lubricate the I.D. of the gland (04N) with oil. Press the lip seals (05) into the gland with the lips positioned as shown in Figure F-2.

Install a new gasket (05P) over the shoulder on the back of the housing (04A).

Lubricate the lip seal areas on the shaft with oil. Carefully slide the assembled gland and lip seals onto the shaft until the gland seats against the gasket. **Use caution** not to roll or cut the lip seals on the shaft keyway.

Install the nuts (D) and tighten them alternately until the gland is fully seated.

Lubricate the lip seals as indicated in **Barrier Liquids for Optional Double Lipseal in Installation, Section B**.

Reinstall the shaft key (N) and reconnect the driver.

SEAL APPENDIX – SECTION F

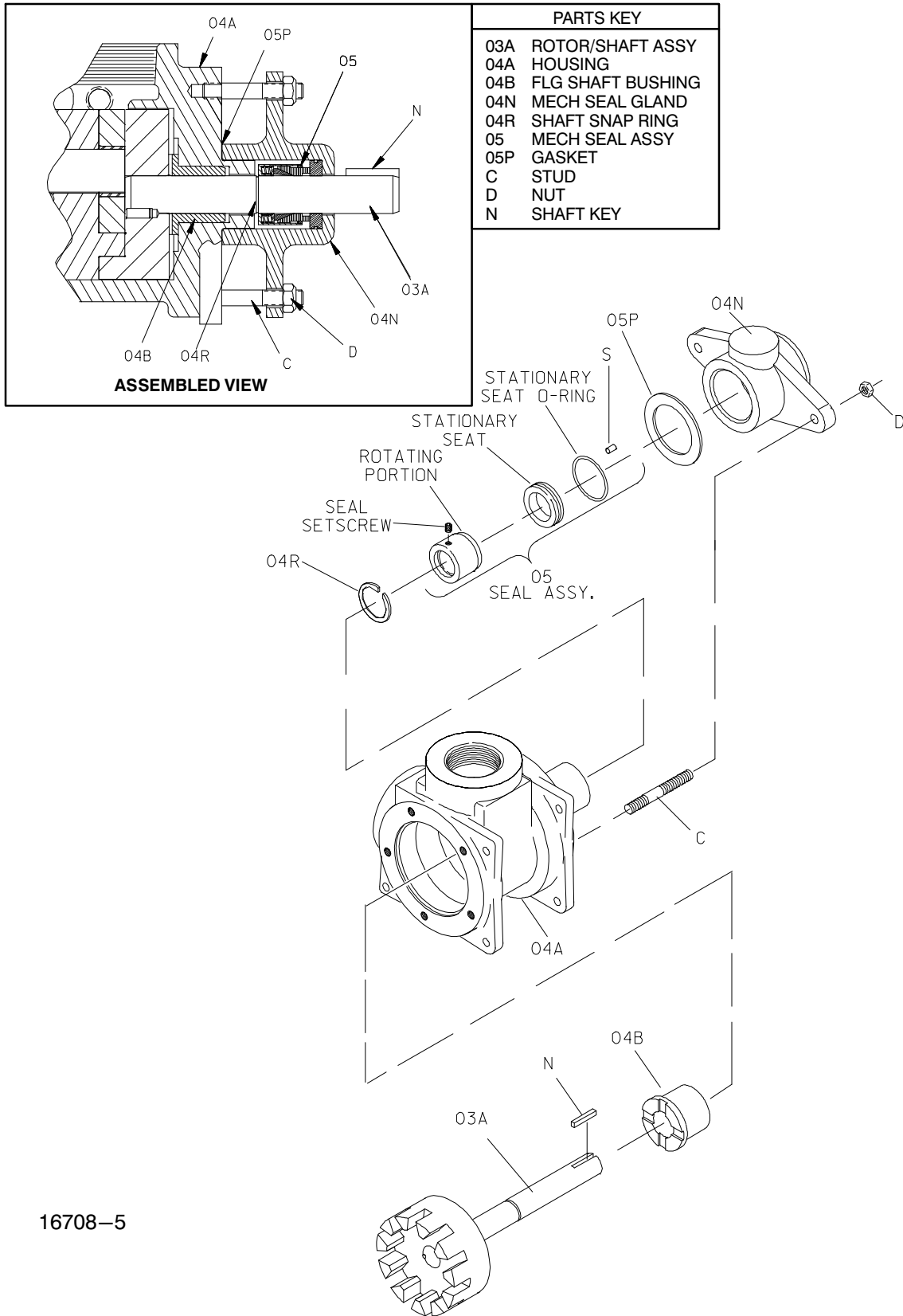

16708-5

Figure F-3. Positive Drive (Option 60D) Seal

Seal Removal

(Figures E-1 and F-3)

Remove the nuts (D) and slide the gland (04N) and stationary seal components off the shaft as a unit. Press the seal stationary seat and O-ring out of the gland from the back side. Remove the gasket (05P).

Use an allen wrench to loosen the seal retainer setscrews. Lightly oil the shaft and slide the rotating portion of the seal off the shaft.

It is not necessary to remove the shaft snap ring (04R) unless the rotor and shaft assembly (03A) is to be removed. Use snap ring pliers to remove the snap ring if required.

Continue as required with **PUMP DISASSEMBLY**.

Seal Installation

(Figures E-1 and F-3)

See **PUMP REASSEMBLY**, and reassemble the pump up to the backhead kit (06).

Clean the seal cavity and shaft with a cloth soaked in fresh cleaning solvent.



Most cleaning solvents are toxic and flammable. Use them only in a well ventilated area free from flame, sparks, and excessive heat. Read and follow all precautions printed on solvent containers.

The seal is not normally reused because wear patterns on the finished faces cannot be realigned during reassembly. This could result in premature failure. If necessary to reuse an old seal in an emergency, **carefully** wash all metallic parts in fresh cleaning solvent and allow to dry thoroughly.



Seal components **must** be kept clean. Handle seal parts with extreme caution to prevent damage. Use care not to contaminate the precision-finished faces; even fin-

gerprints on the faces can shorten seal life. If necessary to clean the faces, use a clean cloth and wipe in a circular pattern.

Inspect the seal components for wear, scoring, grooves, and other damage that might cause leakage. If any components are worn, replace the complete seal; **never mix old and new seal parts**.

If a replacement seal is being used, unwrap the mechanical seal components. Check that the seal faces are clean, undamaged and free of any foreign matter.



New seal assemblies may be equipped with spring holding clips for storage purposes. Do not remove these clips until the seal is installed on the pump shaft. Once the seal is installed, remove and discard these clips using caution so that they do not pop off abruptly and cause personal injury. Failure to remove these clips will result in seal failure and possible pump damage.

If removed, install the shaft snap ring (04R) in the groove in the rotor/shaft assembly (03A). Lightly oil the shaft of the rotor/shaft assembly. Position the rotating portion of the seal on the shaft with the sealing face toward the drive end of the shaft. When the seal is positioned on the full diameter of the shaft, carefully remove the spring holding clips. Continue to slide the seal onto the shaft until the spring retainer seats against the snap ring (05D). Secure the rotating portion of the seal to the shaft by tightening the setscrews in the drive band.

Lubricate the stationary element O-ring with light oil. Position the stationary element in the gland (04N) with the sealing face up. Cover the sealing face with a clean tissue. Use a push tube (I.D. slightly larger than the shaft diameter) to press the stationary element into the gland until fully seated.

Install a new gasket (05P). Carefully slide the assembled gland and stationary seal components onto the shaft until the sealing faces contact. Install the nuts (D) and tighten them alternately until the gland is fully seated.

Reinstall the shaft key (N) and reconnect the driver.

SEAL APPENDIX – SECTION F

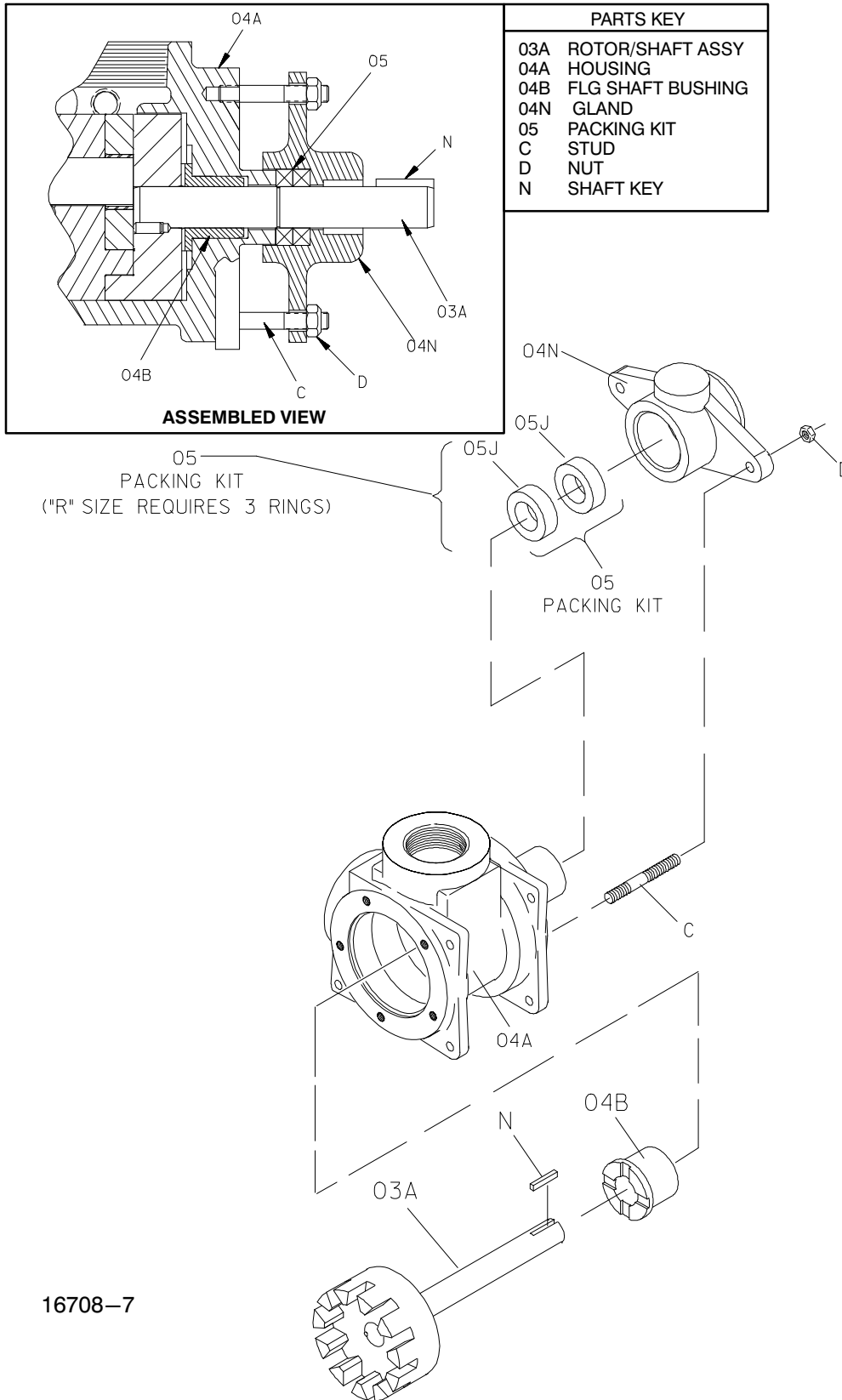

16708-7

Figure F-4. Standard Packing Seal (Option 65)

Seal Removal

(Figures E-1 and F-4)

Separate the pump and driver and remove the shaft key (N).

Remove the nuts (D) and slide the gland (04N) and packing rings (05) off the shaft as a unit. Remove the gasket (05P).

Use a stiff wire with a hooked end to pull the packing rings out of the gland.

Continue as required with **PUMP DISASSEMBLY**.

Seal Installation

(Figures E-1 and F-4)

See **PUMP REASSEMBLY**, and reassemble the pump up to the rotor and shaft assembly (03A).

Clean the seal cavity and shaft with a cloth soaked in fresh cleaning solvent.



WARNING!

Most cleaning solvents are toxic and flammable. Use them only in a well ventilated area free from flame, sparks, and excessive heat. Read and follow all precautions printed on solvent containers.

NOTE

It is recommended that replacement packing rings pre-cut to the correct width and length and packaged in sets (see the separate Parts List accompanying your pump) be ordered from your Gorman-Rupp distributor or the factory. However, if bulk commercial packing will be used, prepare and install it in accordance with the steps outlined below in order to ensure that the packing will form a tight seal.

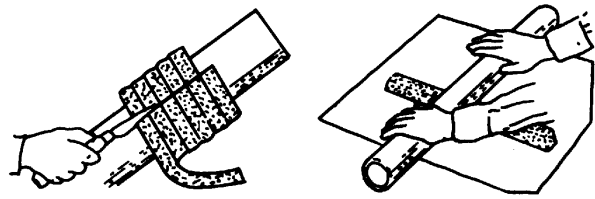

Figure F-4A.

Step 1: Determine how much bulk packing will be required to fill the seal cavity and wrap it around a rod the same diameter as the shaft. With the packing wrapped around the rod, cut through each turn as shown in Figure F-4A.

If the cut rings are too thick and will not fit in the packing cavity, place each turn on a clean piece of paper and use a length of pipe to roll the ring until the thickness has been reduced. **Never** attempt to flatten a packing ring with a hammer.



Figure F-4B.

Step 2: It is critical that the ends of the cut packing ring meet in a tight parallel fit to ensure proper sealing. Check this fit; it should be correct if the packing was cut while wrapped around a rod, but if the packing was cut while laid out straight the ends will meet at an angle. **Never** install packing rings with an angled gap; pressure on adjacent packing rings will cause them to work into the gap and prevent the angled ring from closing properly around the shaft.

Some channel-type packing with a lead core may require a slight gap between packing rings to allow for expansion. Consult the packing manufacturer's installation instructions and follow the recommendations.

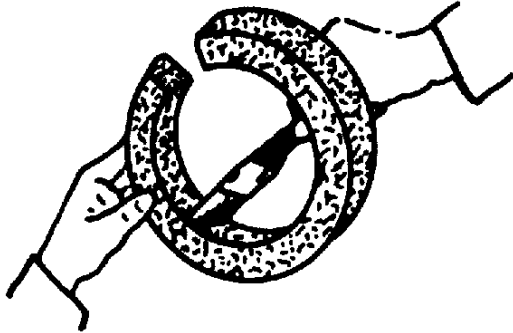

Figure F-4C.

Step 3: Lubricate all metallic packings (foil type, lead core, etc.) with the lubricant recommended by the manufacturer. Generally swabbing the I.D. of the packing with SAE No. 30 non-detergent oil provides sufficient lubrication.

Lubricate the new packing rings with non-detergent oil before installation. For best performance, do not stretch or separate packing braids.

Position a dowel the same diameter as the shaft in the center of the gland bore. Wrap the packing rings around the dowel so the ends of each ring are 180° opposite each other and press them into the lubricated gland bore.

Install a new gasket (05P) over the shoulder on the back of the housing (04A).

Remove the dowel from the gland bore. Carefully slide the assembled gland and packing rings onto the shaft until the packing rings seat against the back shoulder on the housing (04A).

Install the nuts (D) and tighten them alternately until the gland begins to compress the packing rings. Do not over-tighten the gland nuts. They should be tight enough to hold the packing in place and still allow the shaft to turn freely.



Do not overtighten the gland nuts. If the packing rings are compressed too tightly, they may cause the shaft to overheat and damage the pump.

Reinstall the shaft key (N) and reconnect the driver.

Final Packing Adjustment

Start the pump and tighten the gland nuts evenly while the pump is operating. A slight flow of liquid should flow through the packing (8–10 drops per minute). Do not over-tighten the gland nuts and cut off this flow. After the gland has been adjusted, stop the pump. The shaft should rotate freely. If it does not, the gland is too tight.

Replace the packing if the flow of liquid through the packing cannot be controlled by adjusting the gland.

O-RING APPENDIX – SECTION G

O-ring Part Numbers are based on the hydraulic size of the pump, which is included in the pump model number. In the following example, the first letter in the hydraulic size is the rotor diameter code. The second letter indicates tooth length. **O-ring part numbers are keyed to the first letter in the hydraulic field.**

(every pump does not necessarily use each O-ring identified). O-ring part numbers begin with a 5-digit family number which identifies the O-ring material. To identify the appropriate 5-digit family number, refer to the Parts List accompanying the pump. The last 3 digits completing the part number are based on the hydraulic size of the pump.

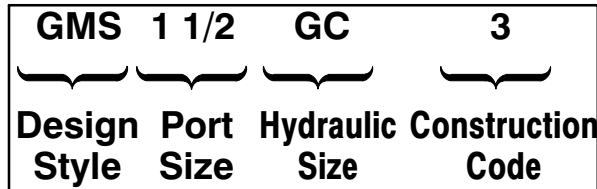

Example: Model GMS1 1/2GC3. If the Parts List accompanying the pump indicates that it is equipped with Viton® O-rings (family group 25154), then the Coverplate/Relief Valve O-ring (Item 10C) would be Part Number 25154-029. Correspondingly, if the O-rings were Neoprene®, Item 10C Part Number would be 25151-029.

In the chart below, the **Item Number** refers to O-rings identified in the Parts Keys in Sections E and F

O-RING FAMILY NUMBERS			
5-DIGIT FAMILY	O-RING MATERIAL	5-DIGIT FAMILY	O-RING MATERIAL
25151-	NEOPRENE®	25156-	KALREZ®
25152-	BUNA-N	25157-	TEFLON®-ENCAPSULATED
25154-	VITON®	25158-	CHEMRAZ®

O-RING SUFFIX (DASH) NUMBERS								
ITEM NO.	HYD. GROUP SIZE	DASH NUMBER	ITEM NO.	HYD. GROUP SIZE	DASH NUMBER	ITEM NO.	HYD. GROUP SIZE	DASH NUMBER
01C	D	-144	10AG	D	-028	10C	D	-021
	G	-152		G	-028		G	-029
	J	-159		J	-034		J	-135
	N	-164		N	-034		N	-135
	R	-172		R	-042		R	-145
01E	D	-021	10AJ	D	-033			
	G	-029		G	-033			
	J	-135		J	-040			
	N	-135		N	-040			
	R	-145		R	-045			
06G	D	-135						
	G	-152						
	J	-159						
	N	-164						
	R	-172						

NOTE: Neoprene, Kalrez, Teflon and Viton are Registered Trademarks of the DuPont Corp. Chemraz is a Registered Trademark of Green, Tweed and Co.

Table G-1. O-Ring Information

**For Warranty Information, Please Visit
www.grpumps.com/warranty
or call:
U.S.: 419-755-1280
Canada: 519-631-2870
International: +1-419-755-1352**

GORMAN-RUPP PUMPS