



HS AND HSV SERIES HYDRAULIC SUBMERSIBLE PUMPS

**MANUAL
PART 1 of 3**

INSTALLATION AND OPERATION

GORMAN-RUPP PUMPS

www.grpumps.com

INTRODUCTION

Thank You for purchasing a Gorman-Rupp Hydraulic Submersible Pump. **Read this manual** carefully to learn how to safely install and operate your pump. Failure to do so could result in personal injury or damage to the pump.

A set of manuals accompanies your pump. Each set consists of three parts; the Installation/Operation Manual contains essential information on installing and operating the pump. However, since pump installations are seldom identical, some of the information only summarizes general recommendations and practices required to inspect, position, and arrange the pump and piping.

The Parts List Manual provides a performance curve, pump model cross-section drawing, and parts list for your pump.

The Maintenance and Repair Manual provides troubleshooting and maintenance instructions required to properly diagnose operational problems, and to service the pump components.

The pump is a hydraulic motor-driven submersible model, capable of handling liquids that may be volatile or flammable, and which could cause serious illness or injury through direct exposure or emitted fumes.

The pump is designed to be driven **only** by an open-center type hydraulic power source with flows and pressures **not exceeding** the nominal specifications shown for your pump in Table 1, Section B. **Do not use closed-center valves or operate the pump at higher flows or pressures.** Closed-center valves or operation at higher flows or pressures will damage the pump motor and/or seal, and **void the pump warranty.** Consult the factory for additional information concerning the appropriate hydraulic power source.

If there are any questions regarding the pump which are not covered in this manual or in other literature accompanying the unit, please contact your Gorman-Rupp distributor or the Gorman-Rupp Company:

The Gorman-Rupp Company
P.O. Box 1217
Mansfield, Ohio 44901-1217
 or:
Gorman-Rupp of Canada Limited
70 Burwell Road
St. Thomas, Ontario N5P 3R7

CONTENTS

SAFETY – SECTION A

INSTALLATION – SECTION B

PREINSTALLATION INSPECTION	PAGE B – 1
Lubrication	PAGE B – 1
PUMP INSTALLATION	PAGE B – 2
Pump and Power Source Specifications	PAGE B – 1
Lifting	PAGE B – 3
Hydraulic Power Source Connections	PAGE B – 3
Rotation	PAGE B – 3
Positioning the Pump	PAGE B – 4
PIPING	PAGE B – 4

OPERATION – SECTION C

STARTING	PAGE C – 1
OPERATIONAL CHECKS	PAGE C – 2
Hydraulic Oil Level/Temperature	PAGE C – 2
Low Oil Shutdown	PAGE C – 2
Oil Cooler	PAGE C – 2
System Leaks	PAGE C – 2
STOPPING	PAGE C – 5
BEARING TEMPERATURE CHECK	PAGE C – 5

RECORDING MODEL AND SERIAL NUMBERS

Please record the model and serial number for your Hydraulic Submersible Pump in the spaces provided below. Your Gorman-Rupp distributor needs this information when you require parts or service.

Model: _____

Serial Number: _____

WARRANTY INFORMATION

The warranty provided with your Hydraulic Submersible Pump is part of Gorman-Rupp’s support program for customers who operate and maintain their equipment as described in this and the other accompanying literature. Please note that should

The following are used to alert personnel to procedures which require special attention, to those which could damage equipment, and to those which could be dangerous to personnel:



Immediate hazards which WILL result in severe personal injury or death. These instructions describe the procedure required and the injury which will result from failure to follow the procedure.



Hazards or unsafe practices which COULD result in severe personal injury or death. These instructions describe the procedure required and the injury which could result from failure to follow the procedure.

the equipment be abused or modified to change its performance beyond the original factory specifications, the warranty will become void and any claim will be denied.

If the pump is to be powered by any source other than a Gorman-Rupp hydraulic submersible power source, contact the Gorman-Rupp Company before installing and operating the equipment. Gorman-Rupp assumes no responsibility for damage to the pump or any other hydraulic equipment due to misapplication of the pump, or use with a non-approved power source.

NOTICE

Gorman-Rupp assumes no responsibility, either expressed or implied, for environmental damage resulting from leakage or spills which may occur during operation or storage of this equipment.



Hazards or unsafe practices which COULD result in minor personal injury or product or property damage. These instructions describe the requirements and the possible damage which could result from failure to follow the procedure.

NOTE

Instructions to aid in installation, operation, and maintenance or which clarify a procedure.

SAFETY - SECTION A

This information applies to HS and HSV Series submersible hydraulic motor driven pumps.



Before attempting to service the hydraulic power source or pump:

1. Familiarize yourself with this manual.
2. Shut down the hydraulic power source and take precautions to ensure that it will remain inoperative.
3. Allow the hydraulic oil to cool before attempting to disconnect or service the pump.



This pump is designed to pump materials that may be volatile or flammable. **Do not** attempt to pump any liquids for which the pump is not designed, or which may damage the pump or endanger personnel as a result of pump failure. Consult the factory for specific application data.



This pump is designed to pump materials which could cause serious illness or injury through direct exposure or emitted fumes. Wear protective clothing, such as rubber gloves, face mask and rubber apron, as necessary, before disconnecting or servicing the pump or piping.



Use lifting and moving equipment in good repair and with adequate capacity to prevent injuries to personnel or damage to equipment. Attach adequate lifting equipment only to the lifting device on the pump. Hydraulic hoses to the power source **must** be removed before lifting. Make certain that all personnel are clear of the area before lifting.



After the pump has been installed, make certain that the pump and all piping or hose connections are tight, properly supported and secure before operation.



Do not operate an internal combustion engine in an explosive atmosphere. When operating internal combustion engines in an enclosed area, make certain that exhaust fumes are piped to the outside. These fumes contain carbon monoxide, a deadly gas that is colorless, tasteless, and odorless.



Fuel used by internal combustion engines presents an extreme explosion and fire hazard. Make certain that all fuel lines are securely connected and free of leaks. Never refuel a hot or running engine. Avoid overfilling the fuel tank, and clean up any fuel spills immediately.

diately. Always use the correct type of fuel.



If using a customer-installed power source, **do not** use closed-center valves. Return flow from the hydraulic motor must be allowed to return directly to the oil reservoir to enable the pump impeller to gradually slow to a stop. Closed-center valves will block this flow, causing damage to the hydraulic motor and/or the pump seal.

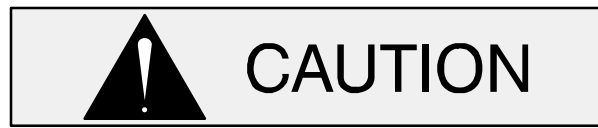

Make sure hydraulic hose connections are fully tightened. Hydraulic hoses are equipped with check valves in each end to prevent oil from escaping when disconnected. Hose connections **must** be tight to fully open these check valves. Failure to tighten connections can cause excessive hydraulic system pressure, resulting in damage to the hydraulic motor and/or other components.

INSTALLATION – SECTION B

Review all SAFETY information in Section A.

This section is intended only to summarize recommended installation practices for the pump. If there are any questions concerning your specific application, contact your Gorman-Rupp distributor or the Gorman-Rupp Company.

PREINSTALLATION INSPECTION

The pump was inspected and tested before shipment. Before installation, inspect the pump for damage which may have occurred during shipment. Check as follows:

- a. Inspect the pump assembly for cracks, dents, damaged threads on the hydraulic connecting hoses, and other obvious damage.
- b. Check for and tighten loose attaching hardware. Since gaskets tend to shrink after drying, check for loose hardware at mating surfaces.
- c. If the pump was shipped with hydraulic hoses, inspect the hoses for cuts or damage to the threaded ends.
- d. Check the pump hydraulic motor for any oil leaks, and tighten any hardware as required.
- e. Carefully read all tags, decals, and markings on the pump assembly, and perform all duties as indicated.
- f. Check that the hydraulic power source provides the required horsepower and flow to properly and safely operate the pump (see Table 1).

If anything on the pump appears to be abnormal, contact your Gorman-Rupp distributor or the factory to determine the repair or updating policy. **Do**

not put the pump into service until appropriate action has been taken.

Lubrication

The pump was fully lubricated when shipped from the factory. However, **always** check the lubricant level before installing the pump (see **LUBRICATION** in **MAINTENANCE AND REPAIR**).

PUMP INSTALLATION

Pump and Power Source Specifications

The Gorman-Rupp Company manufactures a hydraulic power unit specifically designed to power the hydraulic pump. **Only open-center valves** may be used in a customer-supplied power source, with flows and pressures **not exceeding** the nominal specifications shown for your pump in Table 1. **Do not use closed-center valves, or operate the pump at higher flows or pressures.** Closed-center valves or operation at higher flows or pressures will damage the pump motor and/or seal, and **void the pump warranty.**



Do not use closed-center valves. Return flow from the hydraulic motor must be allowed to return directly to the oil reservoir to enable the pump impeller to gradually slow to a stop. Closed-center valves will block this flow, causing damage to the hydraulic motor and/or the pump seal.

See Figure 1 for a typical hydraulic schematic for a customer-supplied power source. Consult the factory for additional information concerning the appropriate hydraulic power source.

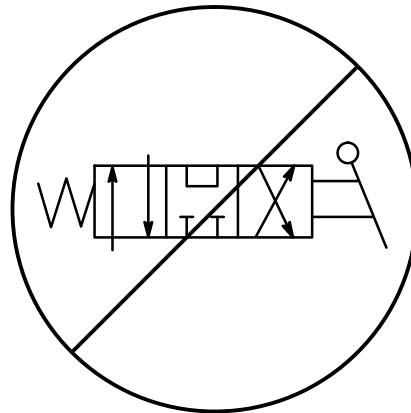
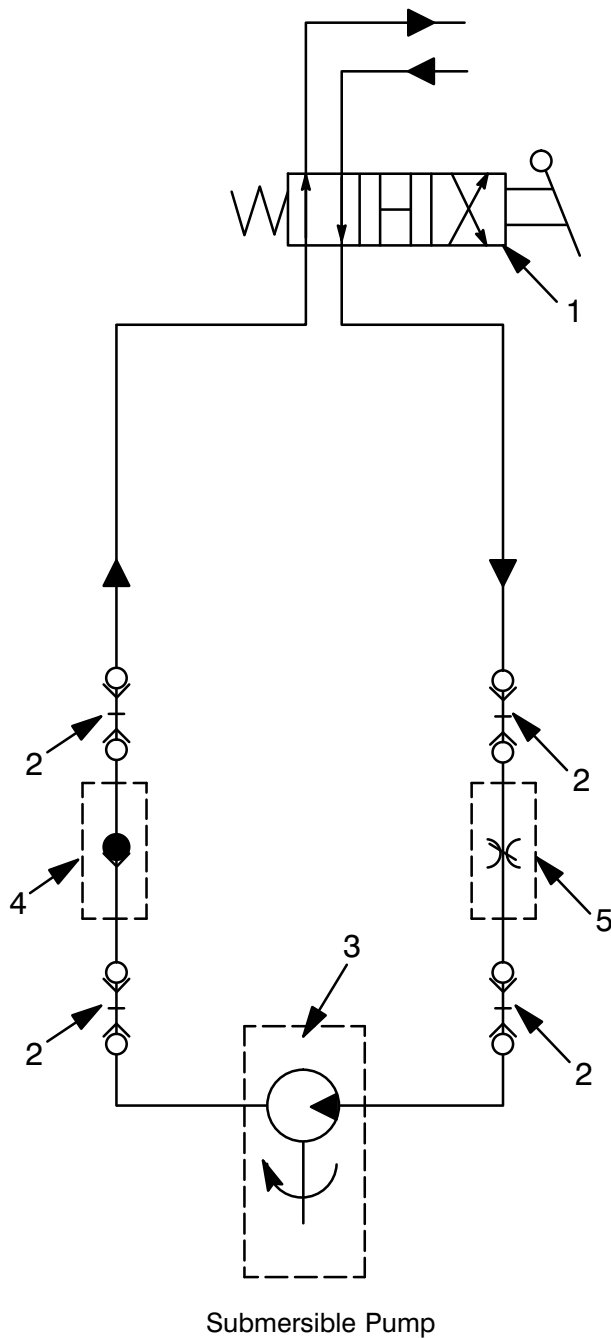

WARNING!

Do not use closed-center valves. Return flow from the hydraulic motor must be allowed to return directly to the oil reservoir to enable the pump impeller to gradually slow to a stop. Closed-center valves will block this flow, causing damage to the hydraulic motor and/or the pump seal.

Legend

- 1) 4-Way Open-Center Directional Valve (Must be operated in forward direction only or use check valve (4) to prevent reversing.)
- 2) Valved Quick Disconnect Coupling
- 3) Hydraulic Motor Driven Submersible Pump
- 4) Check Valve (Recommended)
- 5) Flow Control (Recommended if hydraulic flow is greater than flow required by submersible pump.)

Figure 1. Typical Hydraulic Schematic for Customer-Supplied Power Source (Including Hydraulic Pump)

Table 1. Pump and Nominal Hydraulic Power Source Specifications

Pump Model	Min. Power Source Horsepower	Max. Hydraulic Output	Max. Operating Pressure	Min. Reservoir Capacity
HSV4A31-HYD HSV6A31-HYD HSV6B31-HYD	60	32 GPM (7260 LPH)	2900 PSI (205 kg/cm ²)	45 U.S. Gal (170 L)
HSV3A1-HYD HSV3B31-HYD	10	8 GPM (1817 LPH)	2500 PSI (176 kg/cm ²)	4 U.S. Gal (15 L)

Lifting

Use lifting and moving equipment with a capacity of at least **5 times** the weight of the pump, not including the weight of any customer installed accessories. Customer-installed equipment such as discharge piping **must** be removed before attempting to lift. Refer to the Pump Specification Data Sheet or contact the Gorman-Rupp Company for the approximate weight of your pump.



Do not attempt to lift the pump by the hydraulic hoses or the piping. Attach proper lifting equipment to the lifting device fitted to the pump. If chains or cable are wrapped around the pump to lift it, make certain that they are positioned so as not to damage the pump, and so that the load will be balanced.

Hydraulic Power Source Connections

The hydraulic connections on the hoses supplied with the pump are male and female. The threads on these hoses must be kept clean and protected. Be sure hydraulic hoses and connections are clean before making connections at the pump and power source. Check connections to be sure they are tight before starting the power source.



Make sure hydraulic hose connections are fully tightened. Hydraulic hoses are equipped with check valves in each end. Hose connections **must be tight** to fully open these check valves. Failure to tighten connections can cause excessive hydraulic pressure, resulting in damage to the hydraulic motor and/or other components.

Rotation

Before putting the pump into service, check pump rotation.



While checking impeller rotation, secure the pump to prevent rolling.

Suspend the pump by the lifting handle. **Quickly** apply power and note the direction of pump kickback. **As viewed from the top**, the pump should kickback in a **counterclockwise** direction (see Figure 2); this will indicate that impeller rotation is correct.

If the pump kicks back in a clockwise direction, impeller rotation is incorrect. Consult the **Maintenance and Repair** manual and make sure pressure is supplied to correct port of the hydraulic motor. Recheck pump kickback; it should now be in a counterclockwise direction.

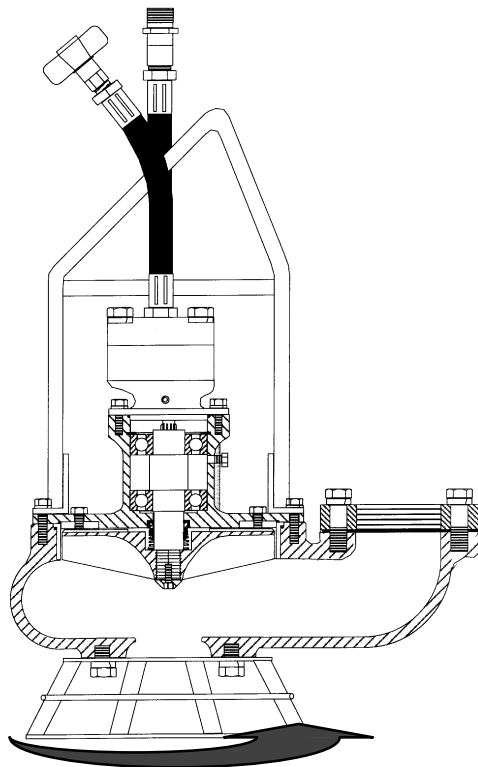

DIRECTION OF KICKBACK

Figure 2. Kickback Direction (All Models)

Positioning the Pump

NOTE

Refer to **OPERATION**, Section C and perform a test on dry land before submerging the pump.

This pump is designed to operate fully or partially submerged. It may also be operated in air for extended periods.

The pump will operate if positioned on its side, but this is not recommended because the hydraulic motor torque could cause the pump to roll during operation.

The pump should be independently secured and supported by the lifting device fitted on the pump. If the application involves a lot of debris, protect the pump from excessive wear and clogging by suspending it in a perforated barrel or culvert pipe. If the bottom is heavily sludge-covered, rest the pump on support blocks or suspend it from a raft or similar device near the surface of the liquid. See Figure 2 for typical pump installations.

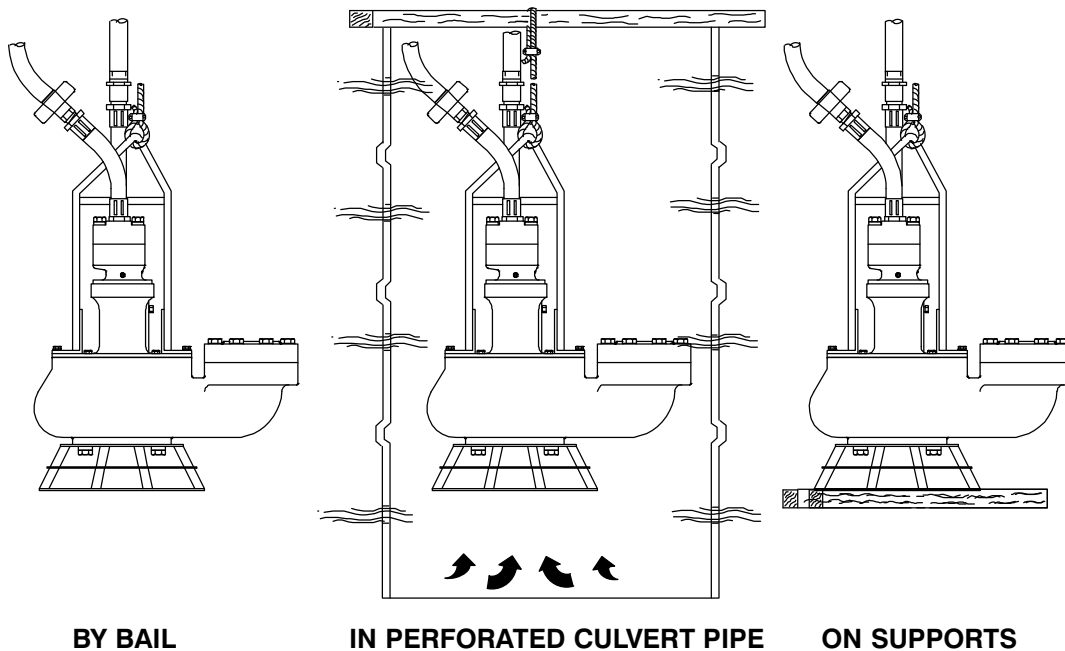

BY BAIL

IN PERFORATED CULVERT PIPE

ON SUPPORTS

Figure 3. Typical Pump Installations

PIPING

No suction piping is required in a standard submerged application. The pump is provided with a

suction strainer to prevent large solids from clogging the impeller. All liquid entering the pump must pass through the strainer. Any spherical solids

which pass through the strainer will pass through the pump.

Either hose or rigid pipe may be used for discharge piping. To facilitate mobility and maintenance, it is recommended that the discharge line be fitted with a quick disconnect fitting near the pump. The discharge line must be independently supported to avoid strain and vibration on the pump.

For maximum pumping capacity, keep the discharge as short and straight as possible. Minimize the use of elbows and fittings which increase friction losses through the discharge piping system.

It is recommended that a check valve or throttling valve be installed in the discharge line to control siphoning or back flow when the pump is shut off.

OPERATION – SECTION C

Review all SAFETY information in Section A.

The Gorman-Rupp Company manufactures a hydraulic power unit specifically designed to power the hydraulic pump. A customer-installed power source may be used to operate the pump; however, since operating procedures vary with the power source used, the following instructions apply to operation with a Gorman-Rupp power unit. Consult the factory for specific information using a customer-installed power source.

Refer to the INSTALLATION section of this manual before startup.

Follow the instructions on all tags, labels and decals attached to the power source.



Do not operate an internal combustion engine in an explosive atmosphere. When operating internal combustion engines in an enclosed area, make certain that exhaust fumes are piped to the outside. These fumes contain carbon monoxide, a deadly gas that is colorless, tasteless, and odorless.



Never tamper with the governor to gain more power. The governor establishes safe operating limits that should not be exceeded. Consult the factory or the power unit specification data sheet for the maximum continuous operating speed.



If using a customer-installed power source, **do not** use closed-center valves. Return flow from the hydraulic

motor must be allowed to return directly to the oil reservoir to enable the pump impeller to gradually slow to a stop. Closed-center valves will block this flow, causing damage to the hydraulic motor and/or the pump seal.

STARTING

1. Position the submersible pump away from personnel for a dry test on land.
2. Refer to the engine operation manual, start the engine and allow it to warm up for one or two minutes. (On units equipped with a 45 gallon [170 liter] hydraulic tank, adjust engine speed to 2300 RPM after warm up.)

NOTE

If the engine is equipped with a shutdown system, hold the reset button in until the engine starts and the engine oil pressure is maintained.

3. Turn the hydraulic pressure control valve clockwise until it stops. This energizes the hydraulic system.



Do not use the hydraulic pressure control valve to regulate hydraulic pressure; this valve is on/off only.

4. Check the hydraulic submersible pump to be sure it is operating.
5. Check all connections and the pump hydraulic motor for any oil leaks, and correct as required.



Make sure hydraulic hose connections are fully tightened. Hydraulic hoses are equipped with check valves in each end to prevent oil from escaping when disconnected. Hose connections **must** be tight to fully open these check valves.

Failure to tighten connections can cause excessive hydraulic system pressure, resulting in damage to the hydraulic motor and/or other components.

6. De-energize the hydraulic system. Connect the discharge hose and install the pump as described in **INSTALLATION**, Section B. Energize the hydraulic system again and adjust the engine speed to achieve the desired pump output.
7. If full volume is not required, the engine speed may be slowed down as necessary to conserve fuel. **Do not** increase engine speed once the factory-set system operating pressure is achieved.

NOTE

*Some pump models are equipped with a vented screw (see the Parts Identification List in the **MAINTENANCE AND REPAIR MANUAL**) which is designed to relieve trapped air in the pump casing. The pump will not operate if this trapped air is not removed. If the pump does not produce flow, de-energize the hydraulic system, remove the pump from the wet well or sump, and check to ensure that the hole in the vented screw is not clogged.*

OPERATIONAL CHECKS

Hydraulic Oil Level/Temperature

1. Maintain the hydraulic oil level to the top of the sight glass on the side of the hydraulic reservoir.
2. After initial startup, check the hydraulic oil level in the reservoir. Filling the hydraulic hoses initially will cause the level to drop.
3. During operation, check to be sure the hydraulic oil operating temperature never exceeds

170°F (77°C). If the temperature becomes excessive, shut down the system and allow the oil to cool. Check for insufficient oil in the reservoir, kinked hydraulic hoses, inadequate ventilation of the reservoir or oil cooler, a clogged return line filter (on models equipped with a 45 gallon [170 liter] hydraulic tank, the gauge on the filter will read in the red or above 40 PSI), or the submersible pump may be running dry for extended periods of time.

Low Oil Shutdown

1. The low oil shutdown switch is mounted on the front of the hydraulic oil reservoir (on units equipped with emergency shutdown packages). It will shut down the engine in the event of loss of hydraulic oil to protect against damage to the system.

Oil Cooler

1. If your hydraulic power unit is equipped with an engine-mounted air/oil cooler to cool the hydraulic oil, be sure the cooling fins are kept clean so air can circulate freely through it.

System Leaks

1. Check all system components regularly for leaks. When checking the relief valve, check the control valve and tubing. Replace the valve, and repair or replace tubing, fittings, oil cooler or any other components at the first sign of leakage.

STOPPING

1. To stop the pump, de-energize the system (turn the control valve counter-clockwise).
2. Reduce the engine speed slowly before stopping to prevent possible system damage.

**For Warranty Information, Please Visit
www.grpumps.com/warranty
or call:
U.S.: 419-755-1280
Canada: 519-631-2870
International: +1-419-755-1352**

GORMAN-RUPP PUMPS