

**INSTALLATION, OPERATION,
AND MAINTENANCE MANUAL**
WITH PARTS LIST

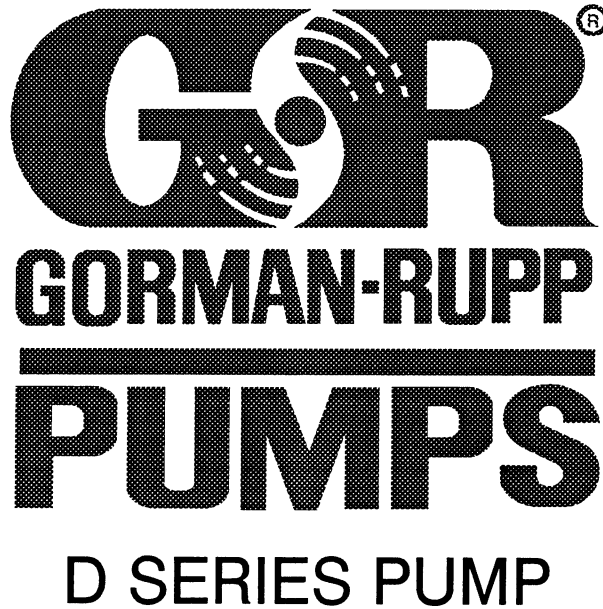

MODEL
3D-6LD325

THE GORMAN-RUPP COMPANY • MANSFIELD, OHIO

GORMAN-RUPP OF CANADA LIMITED • ST. THOMAS, ONTARIO, CANADA Printed in U.S.A.

©Copyright by the Gorman-Rupp Company



The engine exhaust from this product contains chemicals known to the State of California to cause cancer, birth defects or other reproductive harm.

TABLE OF CONTENTS

INTRODUCTION	PAGE I – 1
SAFETY - SECTION A	PAGE A – 1
INSTALLATION – SECTION B	PAGE B – 1
Pump Dimensions	PAGE B – 1
PREINSTALLATION INSPECTION	PAGE B – 1
POSITIONING PUMP	PAGE B – 2
Lifting	PAGE B – 2
Mounting	PAGE B – 2
SUCTION AND DISCHARGE PIPING	PAGE B – 2
Materials	PAGE B – 2
Line Configuration	PAGE B – 2
Fixed, Rigid Piping	PAGE B – 2
Gauges	PAGE B – 3
SUCTION LINES	PAGE B – 3
Fittings	PAGE B – 4
Strainers	PAGE B – 4
Sealing	PAGE B – 4
DISCHARGE LINES	PAGE B – 4
Siphoning	PAGE B – 4
Valves	PAGE B – 4
ALIGNMENT	PAGE B – 4
OPERATION – SECTION C	PAGE C – 1
STARTING	PAGE C – 1
OPERATION	PAGE C – 1
Priming	PAGE C – 1
OPERATION CHECKS	PAGE C – 1
Gearbox Check	PAGE C – 1
Leakage Check	PAGE C – 1
Strainer Check	PAGE C – 1
Accumulator Chamber Check	PAGE C – 1
STOPPING	PAGE C – 2
Cold Weather Preservation	PAGE C – 2
GEARBOX TEMPERATURE CHECK	PAGE C – 2
TROUBLESHOOTING – SECTION D	PAGE D – 1
PUMP MAINTENANCE AND REPAIR - SECTION E	PAGE E – 1
STANDARD PERFORMANCE CHART	PAGE E – 1
PARTS LISTS:	
Pump Model	PAGE E – 3
Diaphragm Pot Assembly	PAGE E – 5
Plunger Rod Assembly	PAGE E – 7
Gearbox Assembly	PAGE E – 9

TABLE OF CONTENTS
(continued)

PUMP AND SEAL DISASSEMBLY AND REASSEMBLY	PAGE E – 10
Suction And Discharge Flap Valve Removal	PAGE E – 10
Diaphragm Removal	PAGE E – 10
Plunger Rod Removal And Disassembly	PAGE E – 10
Gearbox Removal And Disassembly	PAGE E – 11
Gearbox Reassembly And Installation	PAGE E – 12
Plunger Rod Reassembly And Installation	PAGE E – 14
Diaphragm Installation	PAGE E – 14
Suction And Discharge Flap Valve Installation	PAGE E – 15
LUBRICATION	PAGE E – 15
Plunger Rod Assembly	PAGE E – 15
Gearbox	PAGE E – 15
Engine	PAGE E – 15

INTRODUCTION

This Installation, Operation, and Maintenance manual is designed to help you achieve the best performance and longest life from your Gorman-Rupp pump.

This is a D Series, engine-driven, positive displacement pump utilizing a single-action diaphragm to produce a straight-through flow of liquid. The pump is flex-coupled to a 6.5 H.P., four cycle, air-cooled

single cylinder Lombardini diesel engine, model 6LD325.

The pump is ideally suited to industrial and contractor's applications since it will handle liquids ranging from clear water to construction-site muck. The basic material of construction for wetted parts is aluminum, with neoprene flap valves and a **DURABLE 1000™** diaphragm.

If there are any questions regarding the pump or its application which are not covered in this manual or in other literature accompanying this unit, please contact your Gorman-Rupp distributor, or write:

The Gorman-Rupp Company
P.O. Box 1217
Mansfield, Ohio 44901-1217

or

Gorman-Rupp of Canada Limited
70 Burwell Road
St. Thomas, Ontario N5P 3R7

The following are used to alert maintenance personnel to procedures which require special attention, to those which could damage equipment, and to those which could be dangerous to personnel:



Immediate hazards which WILL result in severe personal injury or death. These instructions describe the procedure required and the injury which will result from failure to follow the procedure.



Hazards or unsafe practices which COULD result in severe personal injury or death. These instructions describe the procedure required and the injury which could result from failure to follow the procedure.



Hazards or unsafe practices which COULD result in minor personal injury or product or property damage. These instructions describe the requirements and the possible damage which could result from failure to follow the procedure.

NOTE

Instructions to aid in installation, operation, and maintenance or which clarify a procedure.

SAFETY - SECTION A

This information applies to D Series engine driven diaphragm pumps. Refer to the manual accompanying the engine before attempting to begin operation.



Before attempting to open or service the pump:

1. Familiarize yourself with this manual.
2. Shut down the engine and take precautions to ensure that the pump will remain inoperative.
3. Drain the pump.



This pump is designed to handle non-volatile non-flammable liquids containing specified entrained solids. Do not attempt to pump volatile, corrosive, or flammable liquids which may damage the pump or endanger personnel as a result of pump failure.



After the pump has been located in operating position, make certain that the wheels have been blocked and secured to prevent creeping before attempting to operate the pump.



After the pump has been installed, make certain that the pump and all piping or

hose connections are tight, properly supported and secure before operation.



Do not operate the pump without the eccentric and coupling guards in place over the rotating parts. Exposed rotating parts can catch clothing, fingers, or tools, causing severe injury to personnel.



The gearbox provided on this pump is designed for operation at 2600 RPM maximum input speed. If operated at a higher RPM, pump components may be destroyed.



Never tamper with the governor to gain more power. The governor establishes safe operating limits that should not be exceeded. The maximum continuous operating speed for this pump is 2600 RPM.



Do not operate an internal combustion engine in an explosive atmosphere. When operating internal combustion engines in an enclosed area, make certain that exhaust fumes are piped to the outside. These fumes contain carbon monoxide, a deadly gas that is colorless, tasteless, and odorless.



Fuel used by internal combustion engines presents an extreme explosion and fire hazard. Make certain that all fuel lines are securely connected and free of leaks. Never refuel a hot or running engine. Avoid overfilling the fuel tank. Always use the correct type of fuel.



Never install a positive shut-off valve in the discharge line; discharge restrictions will cause excessive friction loss resulting in overloading and destruction of pump and drive components. It is strongly recommended that unless absolutely necessary, no positive shut-off valve be installed in the suction line; excessive restriction will cause incomplete filling of the diaphragm chamber and result in shortened diaphragm life.

INSTALLATION – SECTION B

Review all **SAFETY** information in Section A.

For further assistance, contact your Gorman-Rupp distributor or the Gorman-Rupp Company.

Since pump installations are seldom identical, this section offers only general recommendations and practices required to inspect, position, and arrange the pump and piping.

Pump Dimensions

See Figure 1 for the approximate physical dimensions of this pump.

OUTLINE DRAWING

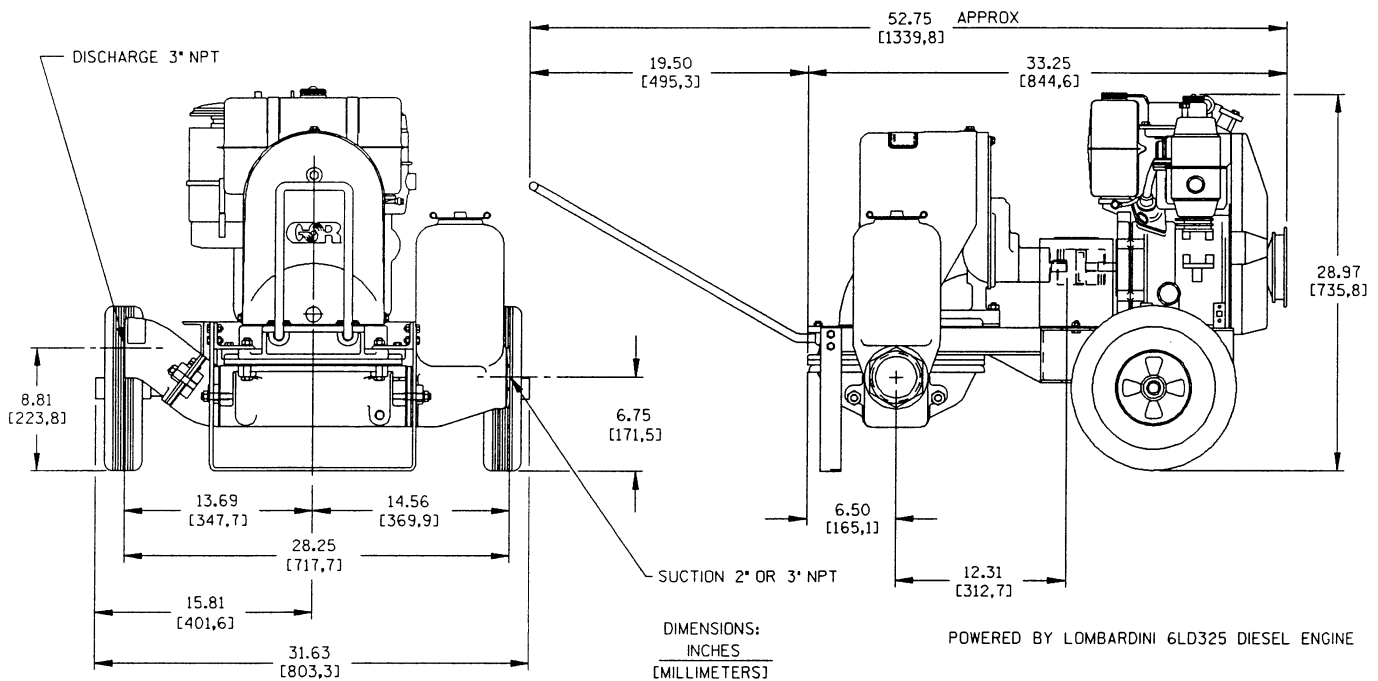

Figure 1. Pump Model 3D-6LD325

PREINSTALLATION INSPECTION

The pump assembly was inspected and tested before shipment from the factory. Before installation, inspect the pump for damage which may have occurred during shipment. Check as follows:

- Inspect the pump and engine for cracks, dents, damaged threads, and other obvious damage.
- Check for and tighten loose attaching hardware. Since gaskets tend to shrink after drying, check for loose hardware at mating surfaces.
- Carefully read all tags, decals, and markings on the pump assembly, and perform all duties indicated.
- Check levels and lubricate as necessary. Refer to **LUBRICATION** in the **MAINTENANCE AND REPAIR** section of this manual and perform duties as instructed.
- If the pump and engine have been stored for more than 12 months, some of the components or lubricants may have exceeded their maximum shelf life. These **must be inspected or replaced** to ensure maximum pump service.

If the maximum shelf life has been exceeded, or if anything appears to be abnormal, contact your Gorman-Rupp distributor or the factory to determine the repair or updating policy. **Do not** put the pump into service until appropriate action has been taken.

POSITIONING PUMP

Lifting

This pump is designed to be easily positioned for operation using the drawbar and wheels. The total pump weight is approximately **275 pounds (125 kg)**, not including accessories or options. Customer installed equipment such as suction and discharge hoses **must** be removed before attempting to lift.



The pump assembly can be seriously damaged if the cables or chains used to lift and move the unit are improperly wrapped around the pump.

Mounting

Locate the pump in an accessible place as close as practical to the liquid being pumped. Level mounting is essential for proper operation.

The pump may have to be supported or shimmed to provide for level operation or to eliminate vibration.

After the pump has been positioned, block the wheels and secure the pump to prevent creeping.

To ensure sufficient lubrication and fuel supply to the engine, **do not** position the pump and engine more than 15° off horizontal for continuous operation. The pump and engine may be positioned up to 30° off horizontal for **intermittent operation only**; however, the engine manufacturer should be consulted for continuous operation at angles greater than 15°.

SUCTION AND DISCHARGE PIPING

Pump performance is adversely effected by increased suction lift, discharge elevation, and friction losses. See Page E-1 to be sure your overall application allows pump to operate within the safe operation range.

Materials

Either pipe or hose maybe used for suction and discharge lines; however, the materials must be compatible with the liquid being pumped. If hose is used in suction lines, it must be the rigid-wall, reinforced type to prevent collapse under suction. Using piping couplings in suction lines is not recommended.

Line Configuration

Keep suction and discharge lines as straight as possible to minimize friction losses. Make minimum use of elbows and fittings, which substantially increase friction loss. If elbows are necessary, use the long-radius type to minimize friction loss.

Never pull a line into place by tightening connections at the pump. Lines near the pump must be independently supported to avoid strain on the pump which could cause excessive vibration and increased diaphragm and gear train wear. If hose-type lines are used, they should have adequate support to secure them when filled with liquid and under pressure.

Fixed, Rigid Piping

This pump is equipped with an integral suction accumulator chamber which promotes an efficient flow of liquid and acts as an air cushion against shock. Since the air in this chamber will leak away during pump operation, the air must be replenished periodically. To introduce air into the chamber, stop the pump and remove the suction accumulator plug and integral gasket; this will break prime and allow the liquid in the chamber to drain away through the suction line.

If the pump is mounted in a system with fixed, rigid piping, it is recommended that a flexible connection be installed at or near the suction and discharge ports to absorb shock which would otherwise be transmitted through the drive train and greatly accelerate pump wear.

In a fixed piping installation, properly sized surge suppressors **must** be installed in both suction and discharge lines. If commercial surge suppressors are not readily available, air chambers may be fabricated from pipe as shown in Figure 2.

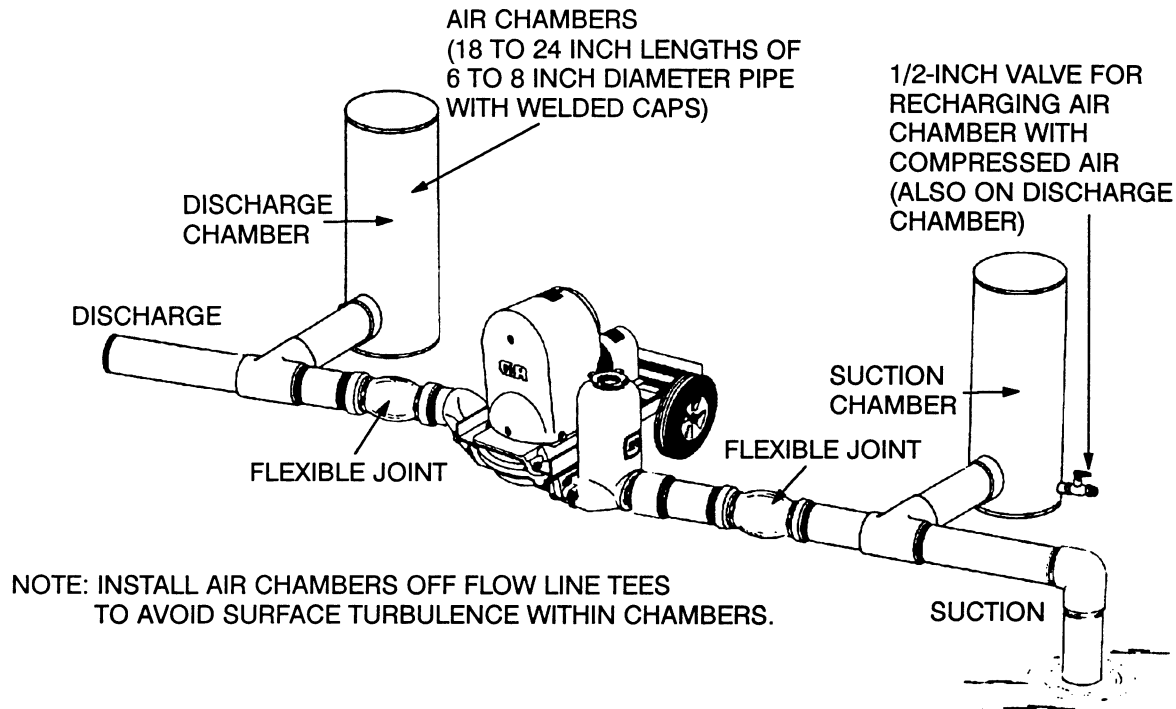

Figure 2. Fixed Piping Installation

Note that the air chambers have not been installed directly in the flow line, but have been installed off tees to avoid turbulence within the chambers. The air chambers are fitted with valves to permit introduction of small amounts of compressed air to further dampen shock; this compressed air will leak away during operation, and should be replaced from time to time. If the suction chamber floods, open the suction chamber valve to break prime and allow the liquid in chamber to drain through the suction line.

Gauges

Most pumps are drilled and tapped for installing discharge pressure and vacuum suction gauges. If these gauges are desired for pumps that are not tapped, drill and tap the suction and discharge lines not less than 18 inches (457,2 mm) from the suction and discharge ports and install the lines. Installation closer to the pump may result in erratic readings.

SUCTION LINES

To avoid air pockets which could affect pump priming, the suction line must be as short and direct as possible. When operation involves a suction lift, the

line must always slope upward to the pump from the source of the liquid being pumped; if the line slopes down to the pump at any point along the suction run, air pockets will be created.

NOTE

Maximum pump performance is realized at suction lifts of 5 feet (1,5 m) or less. Use the shortest possible length of suction hose or piping; lengths of 25 feet (7,6 m) or longer will reduce the capacity of the pump.

It is strongly recommended that no positive shut-off valve be installed in the suction line; excessive restrictions will cause incomplete filling of the diaphragm chamber and result in short diaphragm life.

Fittings

Suction lines should be the same size as the pump inlet. If reducers are used in suction lines, they should be the eccentric type, and should be installed with the flat part of the reducers uppermost to avoid creating air pockets. The suction line should not be restricted more than 1 inch (25,4 mm) below the nominal suction size.

The use of pipe couplings in the suction line is not recommended.

Strainers

If a strainer is furnished with the pump, be certain to use it; any spherical solids which pass through a strainer furnished with the pump will also pass through the pump itself.

If a strainer is not furnished with the pump, but is installed by the pump user, make certain that the total area of the openings in the strainer is at least three or four times the cross section of the suction line, and that the openings will not permit passage of solids larger than the solids handling capability of the pump.

This pump is designed to handle up to 2-1/4 inch (57,1 mm) diameter spherical solids.

Sealing

Since even a slight leak will affect priming, head, and capacity, especially when operating with a high suction lift, all connections in the suction line should be sealed with pipe dope to ensure an airtight seal. Follow the sealant manufacturer's recommendations when selecting and applying the pipe dope. The pipe dope should be compatible with the liquid being pumped.

DISCHARGE LINES



The discharge line must be the same size as, or larger than, the suction line. Never install or operate the pump with a discharge line smaller than the suction; a restricted discharge line will cause excessive friction loss resulting in overloading and destruction of pump and drive components.

Siphoning

Do not terminate the discharge line at a level lower than that of the liquid being pumped unless a siphon breaker is used in the line. Otherwise, a siphoning action causing damage to the pump could result.

Valves

The pump is provided with integral suction and discharge check valves.



Never install a positive shut-off valve in the discharge line; discharge restrictions will cause excessive friction loss resulting in overloading and destruction of pump and drive components. It is strongly recommended that unless absolutely necessary, no positive shut-off valve be installed in the suction line; excessive restriction will cause incomplete filling of the diaphragm chamber and result in shortened diaphragm life.

ALIGNMENT



Before attempting to open or service the pump:

1. **Familiarize yourself with this manual.**
2. **Shut down the engine and take precautions to ensure that the pump will remain inoperative.**
3. **Drain the pump.**



It is imperative that alignment be checked before the pump is operated.

The pump end, gearbox and engine were aligned and secured at the factory, but fastening hardware may have loosened during shipment. It is imperative that this hardware and the alignment be checked after the pump is installed and **before** operation. Adjustments may be made by loosening the securing hardware and shifting or shimming components as required.

To check coupling alignment, use a feeler gauge or taper gauge between the coupling halves every 90°. The coupling is in alignment when the hubs are the same distance apart at all points.

To check parallel adjustment, lay a straightedge across both coupling halves at the top, bottom and sides. The horizontal parallel adjustment is correct when the straightedge rests evenly on both halves of the coupling at all points. Use a feeler gauge between the coupling to measure any misalignment.



Do not operate the pump without the eccentric and coupling guards in place over the rotating parts. Exposed rotating parts can catch clothing, fingers, or tools, causing severe injury to personnel.

OPERATION – SECTION C

Review all **SAFETY** information in Section A.

Follow the instructions on all tags, labels and decals attached to the pump.



This pump is designed to handle non-volatile non-flammable liquids containing specified entrained solids. Do not attempt to pump volatile, corrosive, or flammable liquids which may damage the pump or endanger personnel as a result of pump failure.

Pump application will affect its performance, especially discharge velocities. Consult the Gorman-Rupp factory for actual performance levels for the pump.

Install the pump and piping as described in **INSTALLATION**. Make sure that the piping connections are tight, and that the pump is securely mounted. Check that components are properly lubricated (see **LUBRICATION** in **MAINTENANCE AND REPAIR**).



Make certain that any positive shut-off valve installed in the suction line is open before operating the pump; excessive restriction will cause incomplete filling of the diaphragm chamber and result in shortened diaphragm life. No positive shut-off valve should be installed in the discharge line.

STARTING

Consult the operations manual furnished with the engine. Open any valves installed in the suction line and start the pump.

OPERATION



The pump is designed to operate at ap-

proximately 60 cycles per minute through a gearbox with a 43.36:1 ratio at a maximum input speed of 2600 RPM. Make certain that input speed does not exceed this RPM. Operation at higher RPM can cause pump components to be damaged or destroyed.

Priming

The pump may not prime immediately because the suction line must first fill with liquid. If the pump fails to prime within five minutes, stop the engine and check the suction line for leaks.

OPERATION CHECKS

Gearbox Check

Check that the gearbox is properly lubricated (see **LUBRICATION** in **MAINTENANCE AND REPAIR**).

Leakage Check

No leakage should be visible at pump mating surfaces, connections or fittings. Keep all line connections and fittings tight to maintain maximum pump efficiency.

Strainer Check

If a suction strainer has been installed, check and clean it as necessary. It should be cleaned if pump flow begins to drop. If a vacuum suction gauge has been installed, monitor and record the readings regularly to detect strainer blockage.

Accumulator Chamber Check

Check periodically to ensure that there is sufficient air in the integral suction accumulator chamber. Replenish as required (see **Fixed, Rigid Piping** in Section B for details).

STOPPING

After stopping the pump, shut down the engine and take precautions to ensure that the pump will remain inoperative.

If the pump will be idle for more than a few hours, or if it has been pumping liquids containing a large amount of solids, flush it with clean water.

Cold Weather Preservation

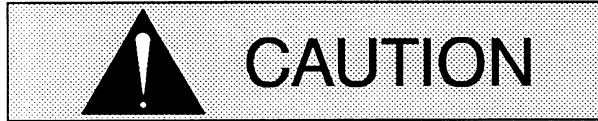

The primary construction materials of this pump are aluminum, with neoprene flap valves and a **DURABLUE 1000™** diaphragm. Do not attempt to clean or flush this pump with any liquid which would attack pump fittings or components. Avoid cleaning with cleaning solvent.

In below freezing conditions, drain the water from the pump and the lines when the pump is not in operation. Also, clean out any solids by flushing with a hose.

GEARBOX TEMPERATURE CHECK

The gearbox runs higher than ambient temperatures because of heat generated by friction. Temperatures of approximately 200°F (93°C) are considered normal, and can operate intermittently at 250°F (121°C).

Checking gearbox temperatures by hand is inaccurate. Place a contact-type thermometer against the housing and record this temperature for future reference.

A sudden increase in gearbox temperature is a warning that the bearings are at the point of failing. Make certain that the bearing lubricant is of the proper viscosity and at the correct level (see **LUBRICATION** in Section E). Bearing overheating can also be caused by shaft misalignment and/or excessive vibration.

When pumps are first started, the bearings may seem to run at temperatures above normal. Continued operation should bring the temperatures down to normal levels within 20 minutes or less.

TROUBLESHOOTING – SECTION D

Review all SAFETY information in Section A.



Before attempting to open or service the pump:

- 1. Familiarize yourself with this manual.**
- 2. Shut down the engine and take precautions to ensure that the pump will remain inoperative.**
- 3. Drain the pump.**

TROUBLE	POSSIBLE CAUSE	PROBABLE REMEDY
PUMP FAILS TO PRIME	Air leak in suction line. Lining of suction hose collapsed. Integral suction or discharge check valve clogged, binding, or not seating properly. Cracked or broken diaphragm. Diaphragm not securely in place. Strainer clogged.	Correct leak. Replace suction hose. Clean valves, check that flange nuts are tight. Replace diaphragm. Secure diaphragm. Check strainer and clean if necessary
PUMP STOPS OR FAILS TO DELIVER RATED FLOW OR PRESSURE	Air leak in suction line. Suction intake not properly submerged. Lining of suction hose collapsed. Cracked or broken diaphragm. Diaphragm not securely in place. Strainer clogged. Integral suction or discharge check valve clogged, binding, or not seating properly.	Correct leak. Check installation. Replace suction hose. Replace diaphragm. Secure diaphragm. Check strainer and clean if necessary Clean valves, check that flange nuts are tight.

TROUBLE	POSSIBLE CAUSE	PROBABLE REMEDY
PUMP REQUIRES TOO MUCH POWER	Liquid solution too thick. Pump speed too high. Integral discharge check valve clogged or binding. Bearings in engine or gearbox worn or binding.	Dilute if possible. Check engine output. Clean valve. Check bearings.
PUMP CLOGS FREQUENTLY	Integral suction or discharge check valve clogged, binding, or not seating properly. Liquid solution too thick.	Clean valves, check that flange nuts are tight. Dilute if possible.
EXCESSIVE NOISE	Pump, gearbox, or engine not securely mounted. Gearbox or engine not properly lubricated.	Check and tighten mounting bolts. See LUBRICATION in MAINTENANCE AND REPAIR .
BEARINGS RUN TOO HOT	Bearing temperature is high, but within limits. Low or incorrect lubricant. Drive misaligned.	Check bearing temperature regularly to monitor any increase. Check for proper type and level of lubricant. Align drive properly.

PUMP MAINTENANCE AND REPAIR - SECTION E

MAINTENANCE AND REPAIR OF THE WEARING PARTS OF THE PUMP WILL MAINTAIN PEAK OPERATING PERFORMANCE.

IN GALLONS PER MINUTE AT 60 STROKES PER MINUTE				
STATIC LIFT IN FEET	STATIC DISCHARGE HEAD IN FEET			
	5	10	15	20
5	78	67	66	68
10	73	64	66	62
15	68	60	64	59
20	64	59	65	59
25	56	56	60	56

IN LITERS PER MINUTE AT 60 STROKES PER MINUTE				
STATIC LIFT IN METERS	STATIC DISCHARGE HEAD IN METERS			
	1,5	3,0	4,6	6,1
1,5	295,2	253,6	249,8	257,4
3,0	276,3	242,2	249,8	234,7
4,6	257,4	227,1	242,2	223,3
6,1	242,2	223,3	246,0	223,3
7,6	212,0	212,0	227,1	212,0

* STANDARD PERFORMANCE TEST DATA FOR PUMP MODEL 3D-6LD325

* Based on 70° F (21° C) clear water at sea level with minimum suction lift, using 2 inch (5,08 cm) suction hose and 3 inch (7,62 cm) non-collapsible discharge hose. Since pump installations are seldom identical, your performance may be different due to such factors as viscosity, specific gravity, elevation, temperature, and impeller trim.

If your pump serial number is followed by an "N", your pump is **NOT** a standard production model. Contact the Gorman-Rupp Company to verify performance or part numbers.



Never tamper with the governor to gain more power. The governor establishes safe operating limits that should not be exceeded. The maximum continuous operating speed for this pump is 2600 RPM.

SECTION DRAWING

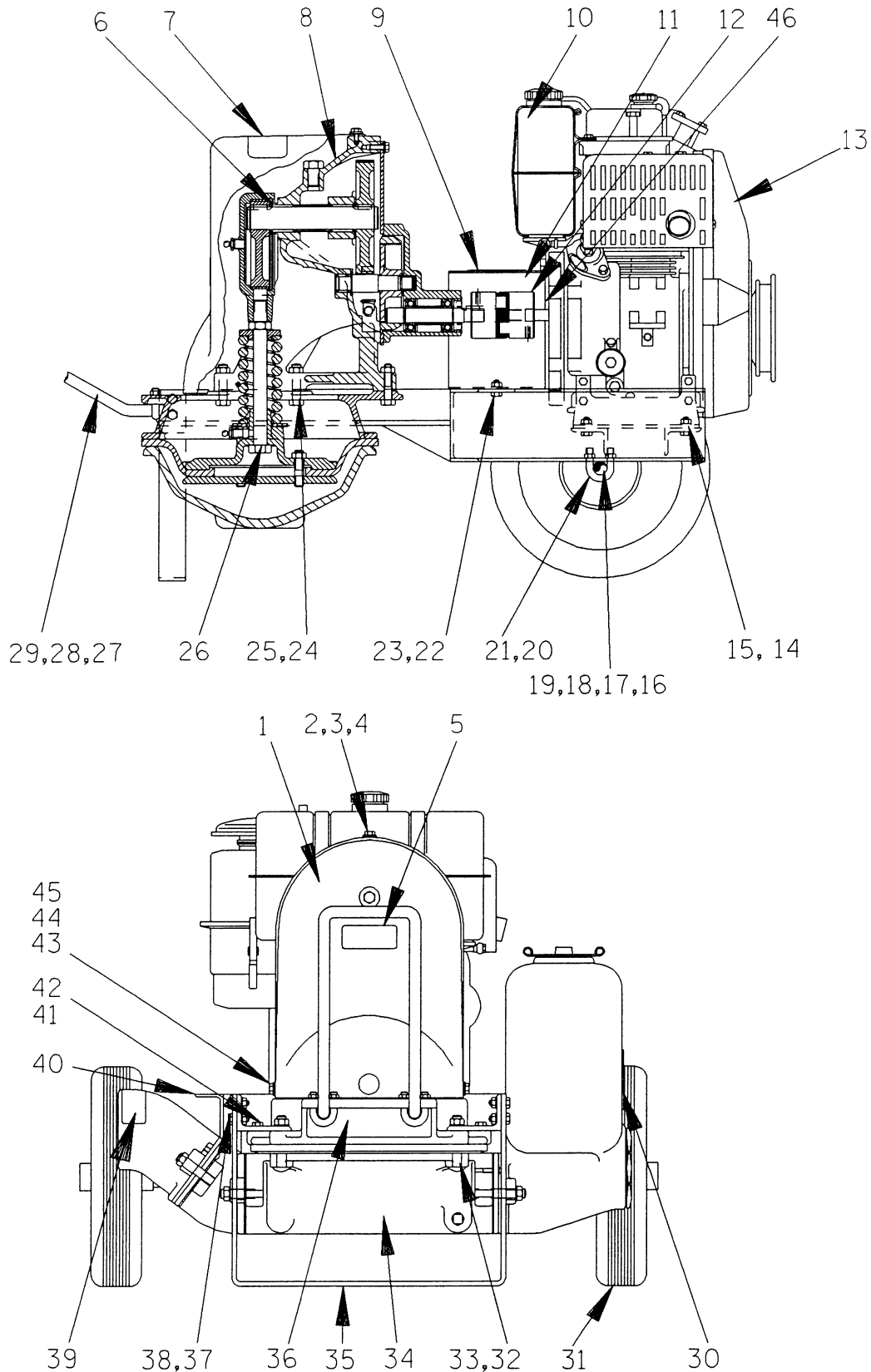

Figure 1. Pump Model 3D-6LD325

PARTS LIST
Pump Model 3D-6LD325
 (From S/N 1022341 up)

If your pump serial number is followed by an "N", your pump is **NOT** a standard production model. Contact the Gorman-Rupp Company to verify part numbers.

ITEM NO.	PART NAME	PART NUMBER	MAT'L CODE	QTY	ITEM NO.	PART NAME	PART NUMBER	MAT'L CODE	QTY
1	ECCENTRIC GUARD	38861-501	23200	1	27	DRAW BAR	5438	15990	1
2	NYLOCK CAPSCREW	BT0403	15991	1	28	U-BOLT	5495	15991	2
3	WASHER	S157	-----	1	29	HEX NUT W/FLANGE	21765-314	-----	4
4	FLAT WASHER	K04	15991	1	30	SUCTION DECAL	6588AG	-----	1
5	LUBRICATION DECAL	38817-066	-----	1	31	PNEUMATIC WHEEL	S263	-----	2
6	SNAP RING	5385	-----	1	32	FLAT WASHER	K08	15991	4
7	GUARD WARNING DECAL	38816-063	-----	1	33	HEX NUT	D08	15991	4
8	GEARBOX ASSY	44161-008	-----	1	34	DIAPHRAGM POT ASSY	46475-701	-----	1
9	GUARD WARNING DECAL	38816-063	-----	1	35	FRONT STAND	13759L	15990	1
10	WARNING DECAL	2613FE	-----	1	36	DIAPHRAGM RING	13582	13010	1
11	COUPLING GUARD	34613-005	15020	1	37	HEX HD CAPSCREW	B0605	15991	4
12 *	COUPLING	48113-004	-----	1	38	HEX NUT W/FLANGE	21765-314	-----	4
13	LOMBARDINI ENGINE	29226-003	-----	1	39	DISCHARGE DECAL	6588BJ	-----	1
14	HEX HD CAPSCREW	B0605	15991	4	40	BASE ASSY	41546-099	24150	1
15	HEX NUT W/FLANGE	21765-314	-----	4	41	HEX HD CAPSCREW	B0604	15991	2
16	AXLE	4607Q	15990	1	42	LOCKWASHER	J06	15991	2
17	CLAMP	S967	-----	2	43	HEX HD CAPSCREW	B0402-1/2	15991	2
18	FLAT WASHER	S1532	-----	4	44	T-TYPE LOCKWASHER	AK04	15991	2
19	HAIRCLIP PIN	21183-010	-----	4	45	FLAT WASHER	K04	15991	2
20	U-BOLT	4610	15990	2	46	SPACER SLEEVE	31411-082	15030	1
21	HEX NUT W/FLANGE	21765-314	-----	4					
22	HEX HD CAPSCREW	B0404	15991	2		NOT SHOWN:			
23	HEX NUT W/FLANGE	21765-310	-----	2		NAME PLATE	2613BP	13990	1
24	HEX HD CAPSCREW	B0608	15991	5		DRIVE SCREW	BM#04-03	15990	4
25	HEX NUT W/FLANGE	21765-314	-----	5		STRAINER	9026D	24001	1
26	PLUNGER ROD ASSY	5685	-----	1		TRADEMARK DECAL	38812-049	-----	1

* INDICATES PARTS RECOMMENDED FOR STOCK

Above Serial Numbers Do Not Apply To Pumps Made In Canada.

CANADIAN SERIAL NO. AND UP

SECTION DRAWING

NOTE:
FLAP VALVE ASSEMBLY SHOWN IN POSITION
ON DISCHARGE SIDE. SUCTION SIDE TO
OPEN IN SAME DIRECTION.

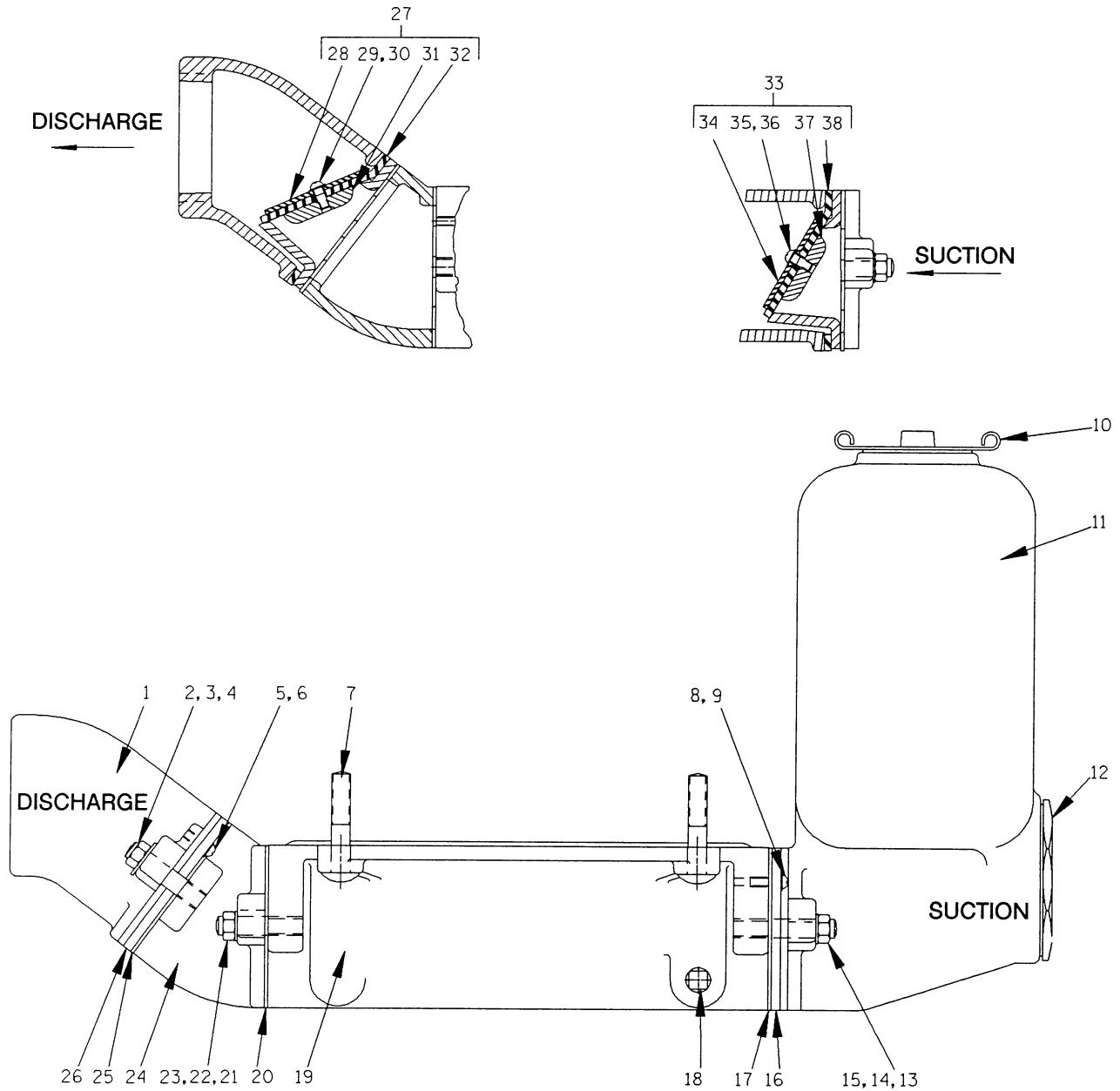

Figure 2. 46475-701 Diaphragm Pot Assembly

PARTS LIST
46475-701 Diaphragm Pot Assembly

ITEM NO.	PART NAME	PART NUMBER	MAT'L CODE	QTY
1	DISCHARGE FLANGE	5658	13040	1
2	STUD	C0810	15991	2
3	HEX NUT	D08	15991	2
4	FLAT WASHER	KE08	15991	2
5	RD HD MACHINE SCREW	X0404	15991	2
6	LOCKWASHER	J04	15991	2
7	RIB MACHINE BOLT	BJ0811	15990	4
8	RD HD MACHINE SCREW	X0404	15991	2
9	LOCKWASHER	J04	15991	2
10	SUCT ACCUMULATOR PLUG AND GASKET	S591A	-----	1
11	SUCTION ACCUMULATOR	5376	13010	1
12	REDUCER PIPE BUSHING	AP4832	11999	1
13	STUD	C0810	15991	2
14	FLAT WASHER	K07	15991	2
15	HEX NUT	D08	15991	2
16	VALVE SEAT	5374	10010	1
17	* SUCTION ACCUMULATOR GASKET	5374G	19100	1
18	DIAPHRAGM POT DRAIN PLUG	P06	15079	1
19	DIAPHRAGM POT	5375	13010	1
20	* DISCHARGE FLANGE GASKET	5374G	19100	1
21	STUD	C0809	15991	2
22	FLAT WASHER	K07	15991	2
23	HEX NUT	D08	15991	2
24	DISCHARGE FLANGE	5377	13040	1
25	* DISCHARGE FLANGE GASKET	5374G	19100	1
26	VALVE SEAT	5374	10010	1
27	DISCHARGE FLAP VALVE ASSY	46413-013	-----	1
28	-VALVE WEIGHT	5428	15990	1
29	-RD HD MACHINE SCREW	X0403	17000	2
30	-LOCKWASHER	J04	17000	2
31	-VALVE WEIGHT	5426	13010	1
32	* -FLAP VALVE	5427	19100	1
33	SUCTION FLAP VALVE ASSY	46413-013	-----	1
34	-VALVE WEIGHT	5428	15990	1
35	-RD HD MACHINE SCREW	X0403	17000	2
36	-LOCKWASHER	J04	17000	2
37	-VALVE WEIGHT	5426	13010	1
38	* -FLAP VALVE	5427	19100	1

* INDICATES PARTS RECOMMENDED FOR STOCK

SECTION DRAWING

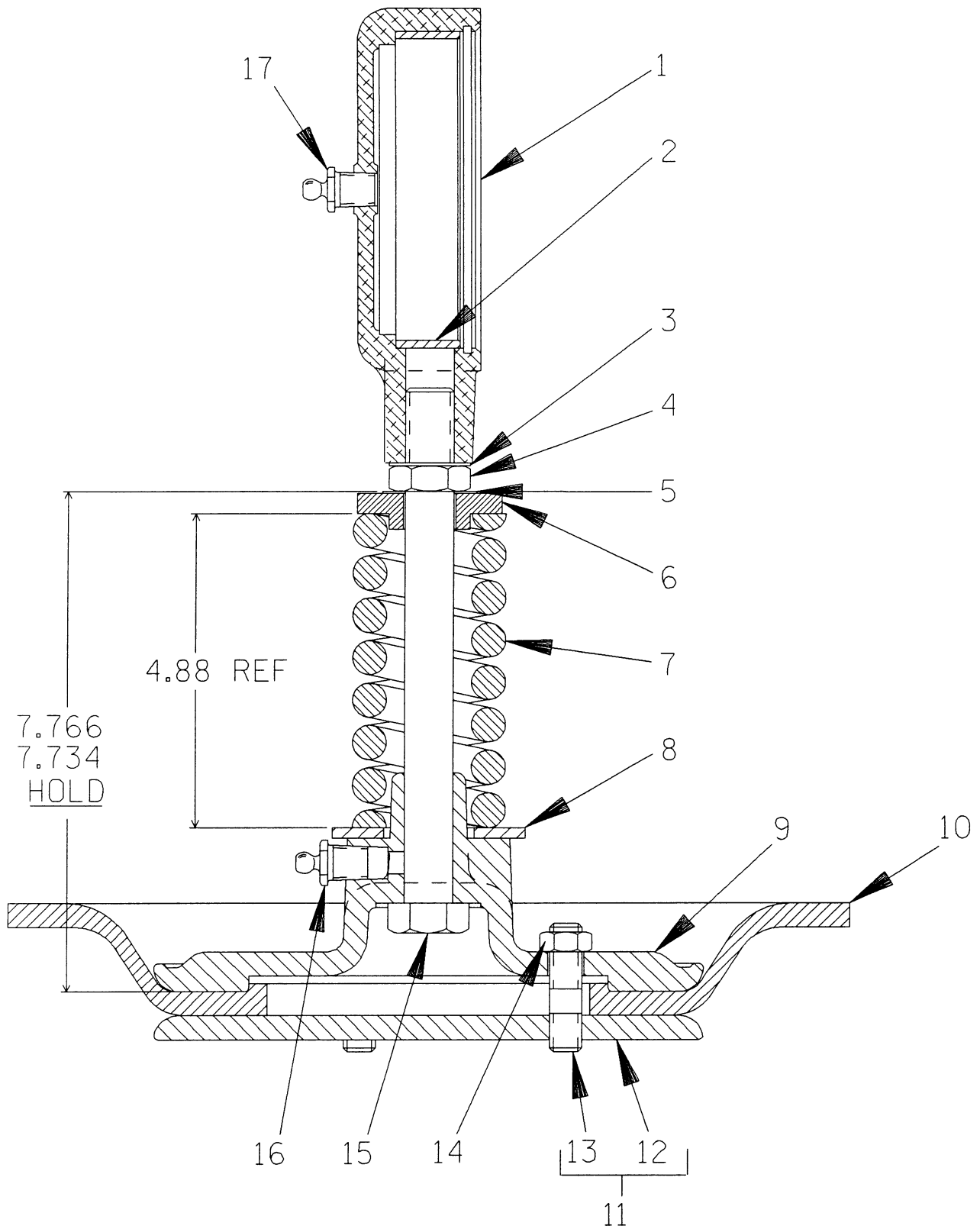

Figure 3. Standard 5685 And Optional 5685B Plunger Rod Assembly

PARTS LIST
5685 Standard Plunger Rod Assembly And
5685B Optional Plunger Rod Assembly

ITEM NO.	PART NAME	PART NUMBER	MAT'L CODE	QTY
1	ECCENTRIC CAP	5373	13010	1
2	* ECCENTRIC BEARING	5610	14000	1
3	T-TYPE LOCKWASHER	AK12	15991	1
4	JAM NUT	AT12	15991	1
5	* ADJUSTING SHIM SET	11840B	15991	4
6	SPRING WASHER	5384	15991	1
7	SPRING	5398	16081	1
8	FLAT WASHER	K20	15991	1
9	DIAPHRAGM PLATE	5381	10010	1
10	STANDARD 'DURABLU 1000™' DIAPHRAGM	26844-041	-----	1
	OPTIONAL 'BUNA-N' DIAPHRAGM	S1042	-----	1
11	DIAPHRAGM PLATE ASSY	5394	-----	1
12	-DIAPHRAGM PLATE	5394A	10030	1
13	-STUD	C0808	15991	3
14	HEX NUT	D08	15991	3
15	PLUNGER ROD	21612-577	-----	1
16	LUBRICATION FITTING	S191	-----	1
17	LUBRICATION FITTING	S191	-----	1
OPTIONAL:				
	OIL RESISTANT DIAPHRAGM	S701	-----	1

* INDICATES PARTS RECOMMENDED FOR STOCK

NOTE: ALL PARTS IDENTICAL BETWEEN STANDARD AND
 OPTIONAL PLUNGER ROD ASSEMBLIES EXCEPT DIAPHRAGM

SECTION DRAWING

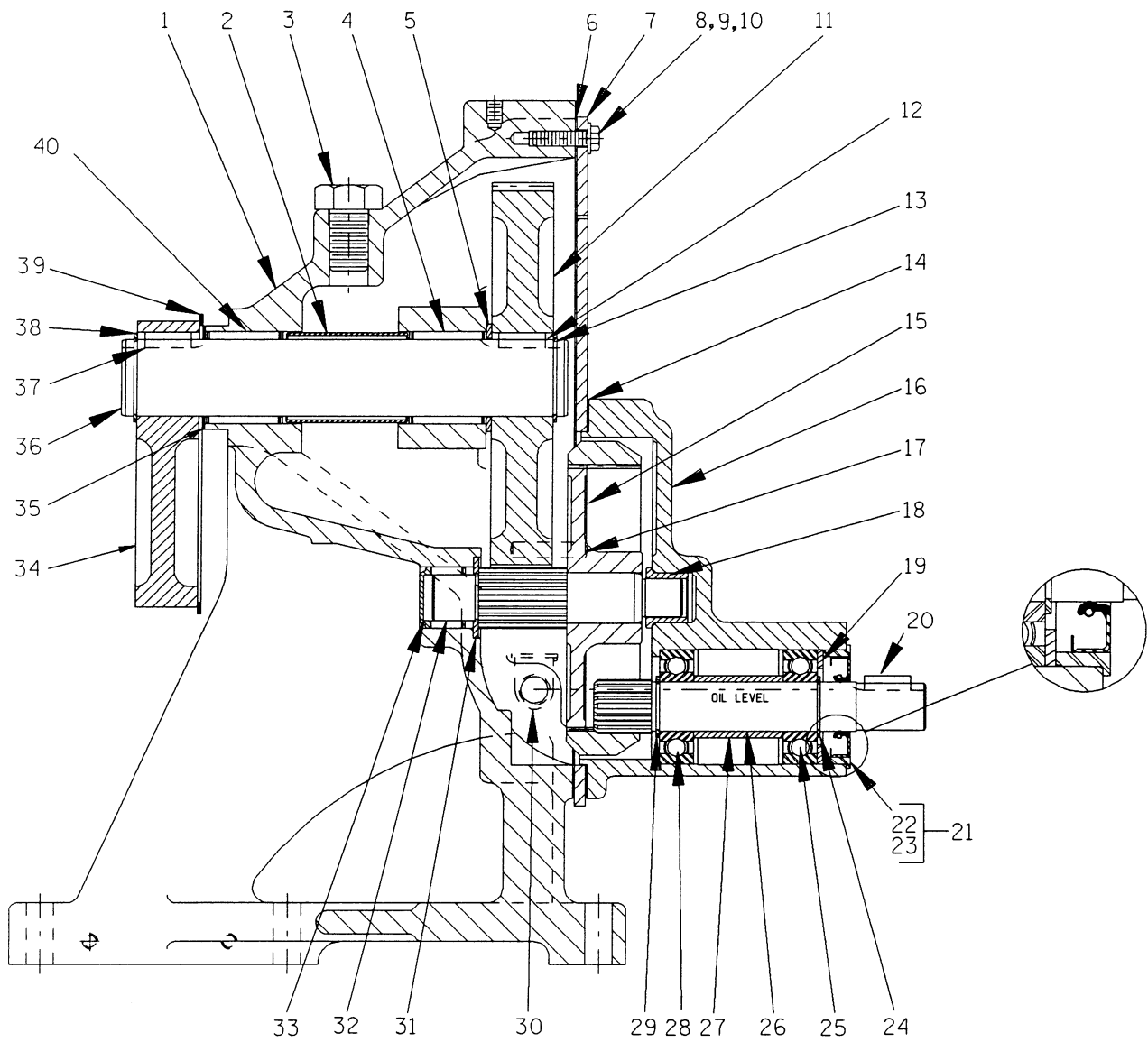

Figure 4. 44161-008 Gearbox Assembly

PARTS LIST
44161-008 Gearbox Assembly

ITEM NO.	PART NAME	PART NUMBER	MAT'L CODE	QTY
1	GEAR HOUSING	5367	13010	1
2	SPACER SLEEVE	S952	-----	1
3	HEX HD CAPSCREW	B1004	15991	1
4	* DRIVE SHAFT BEARING	S702	-----	1
5	SPACER WASHER	5395	15990	1
6	* HOUSING GASKET	5367G	20050	1
7	COVER PLATE	5396	15990	1
8	HEX HD CAPSCREW	B0403	15991	7
9	LOCKWASHER	J04	15991	9
10	HEX HD CAPSCREW	B0407	15991	2
11	DRIVE GEAR	5334	16060	1
12	* DRIVE SHAFT KEY	31811-040	15990	1
13	SNAP RING	S700	-----	1
14	* BEARING HOUSING GASKET	S825	-----	1
15	INTERNAL GEAR	S823	-----	1
16	BEARING HOUSING	5918A	13010	1
17	LOCATING PIN	AA0405	15990	2
18	* PINION BUSHING	S824	-----	1
19	WASHER	2M	15990	3
20	* DRIVE KEY	N0304	15990	1
21	OIL SEAL ASSY	14408	-----	1
22	-OIL SEAL ADAPTOR	14407	15000	1
23	* -OIL SEAL	25227-355	-----	1
24	BEARING SNAP RING	S269	-----	1
25	* DRIVE PINION BALL BEARING	S1044	-----	1
26	PINION DRIVE SHAFT	8211	16070	1
27	SLEEVE	5922	15070	1
28	* DRIVE PINION BALL BEARING	S1044	-----	1
29	BEARING SNAP RING	S269	-----	1
30	OIL CUP	S617	-----	1
31	SPACER WASHER	5382	15991	1
32	PINION SHAFT	5333	16020	1
33	* PINION BEARING	S703	-----	1
34	ECCENTRIC CAM	5378A	10080	1
35	ADJUSTING SHIM SET	13103A	15990	1
36	DRIVE SHAFT	5397	15020	1
37	* DRIVE SHAFT KEY	31811-040	15990	1
38	SNAP RING	S700	-----	1
39	WASHER	6531	18040	1
40	* DRIVE SHAFT BEARING	S702	-----	1

* INDICATES PARTS RECOMMENDED FOR STOCK

PUMP AND SEAL DISASSEMBLY AND REASSEMBLY

Review all SAFETY information in Section A.

Follow the instructions on all tags, label and decals attached to the pump.

This pump requires little service due to its rugged, minimum-maintenance design. However, if it becomes necessary to inspect or replace the wearing parts, follow these instructions which are keyed to the sectional views (see Figures 1, 2, 3 and 4) and the accompanying parts lists.

Before attempting to service the pump, shutdown the engine and take precautions to ensure that it will remain inoperative. Close all valves in the suction and discharge lines.

For engine disassembly and repair, consult the literature supplied with the engine, or contact your local Lombardini engine representative.

Most service functions may be performed without separating the pump and gearbox from the engine. If major repair is required, the pump, gearbox and engine must be disconnected.



Before attempting to open or service the pump:

1. Familiarize yourself with this manual.
2. Shut down the engine and take precautions to ensure that the pump will remain inoperative.
3. Drain the pump.

Before attempting to service the pump, drain the pump by removing the drain plug (18, Figure 2). Clean and reinstall the drain plug.

Suction And Discharge Flap Valve Removal (Figure 2)

To service the suction and discharge flap valves, remove the suction and discharge piping.

To service the suction flap valve assembly (33), remove the suction accumulator (11) by disconnect-

ing the hardware (14 and 15) securing it to the diaphragm pot (19). Remove the hardware (8 and 9) securing the valve seat (16) and flap valve assembly to the diaphragm pot. Pull the flap valve assembly from the suction port.

To service the discharge flap valve assembly (27), remove the hardware (3 and 4) to remove the outboard discharge flange (1). Remove the hardware (5 and 6) securing the valve seat (26) and discharge flap valve assembly to the outboard discharge flange.

To remove the inboard discharge flange (24), remove the hardware (22 and 23) securing the flange to the diaphragm pot. Pull the flap assembly from the discharge port.

The suction and discharge flap valve assemblies are identical parts and operate in the same direction. For removal and/or replacement, remove the hardware (29, 30, 35 and 36) securing the flap valve weights (28, 31, 34 and 37) to the flap valves (32 and 38). Inspect and replace as required.

If no further disassembly is required, see **Suction And Discharge Flap Valve Installation**.

Diaphragm Removal

(Figure 1)

To remove the diaphragm (10, Figure 3), disengage the hardware (32 and 33) and remove the diaphragm pot assembly (34). Inspect the diaphragm ring (36) for wear or damage. If replacement is required, the gearbox assembly (8) must be removed.

(Figure 3)

Remove the nuts (14). Separate the lower diaphragm plate assembly (11) from the diaphragm (10) and the upper diaphragm plate (9). Inspect the diaphragm and replace as required.

If no further disassembly is required, see **Diaphragm Installation**.

Plunger Rod Removal And Disassembly (Figure 1)

With the diaphragm pot assembly and diaphragm removed, disengage the hardware (2, 3, 4, 43, 44 and 45) and remove the eccentric guard (1).

Removing the retaining ring (6) and slide the plunger rod assembly (26) off the eccentric cam drive shaft (36, Figure 4).

(Figure 3)

Use a socket wrench to hold the plunger rod (15) securely, and unscrew the eccentric cap (1). Remove the T-type lockwasher (3), jam nut (4), adjusting shims (5), spring washer (6) and spring (7). Remove the flat washer (8) and slide the plunger rod out of the upper diaphragm plate (9).

Inspect the eccentric bearing (2) for excessive wear. If replacement is necessary, cut the bearing with a chisel. **Be careful** not to damage the eccentric cap.

Gearbox Removal And Disassembly**(Figure 1)**

When properly operated and maintained, the gearbox assembly (8) should not require disassembly. Disassemble the gearbox **only** when there is evidence of wear or damage.



Shaft and bearing disassembly in the field is not recommended. These operations should be performed only in a properly equipped shop by qualified personnel.

Support the diaphragm ring (36) with wooden blocks. Remove the hardware (24 and 25) securing the gearbox to the diaphragm ring. Inspect the diaphragm ring for wear or damage and replace as necessary.

Disengage the hardware (22 and 23) and remove the coupling guard (11). Loosen the hardware securing the coupling (12) and separate the halves. Remove the gearbox assembly, and slide the coupling half off the pinion drive shaft (26, Figure 4).

(Figure 4)

Before attempting to disassemble the gearbox assembly, drain the lubricant by removing the oil cup (30) and turning the gearbox on its side. Clean and reinstall the oil cup.

Remove the two lower and the five upper pieces of hardware (8, 9 and 10) securing the cover plate (7) to the gear housing (1). Pull the bearing housing (16) and cover plate from the pinion shaft (32) and gear

(15). Remove the gasket (6) and clean the mating surfaces. Replace the gasket as necessary.

Remove the remaining two pieces of hardware (9 and 10) and separate the cover plate from the bearing housing. Remove the gasket (14) and clean the mating surfaces. Replace the gasket as necessary.

To disassemble the pinion drive shaft components, remove the key (20) and pry the oil seal assembly (21) from the bearing housing. Press the oil seal (23) from the seal adaptor (22).

Remove the washer (19) and slide the assembled pinion drive shaft (26) and bearings (25 and 28) and sleeve (27) from the bearing housing.

After removing the shaft and bearings, clean and inspect the bearings **in place** as follows.



To prevent damage during removal from the shaft, it is recommended that bearings be cleaned and inspected **in place**. It is **strongly** recommended that the bearings be replaced **any** time the shaft and bearings are removed.

Clean the bearing housing, shaft and all component parts (except the bearings) with a soft cloth soaked in cleaning solvent. Inspect the parts for wear or damage and replace as necessary.



Most cleaning solvents are toxic and flammable. Use them only in a well-ventilated area free from excessive heat, sparks, and flame. Read and follow all precautions printed on solvent containers.

Clean the bearings thoroughly in **fresh** cleaning solvent. Dry the bearings with filtered compressed air and coat with light oil.



Bearings must be kept free of all dirt and

foreign material. Failure to do so will greatly shorten bearing life. **Do not** spin dry bearings. This may scratch the balls or races and cause premature bearing failure.

Rotate the bearings by hand to check for roughness or binding and inspect the bearing balls. If rotation is rough or the bearing balls are discolored, replace the bearings.

The bearing tolerances provide a tight press fit onto the shaft and a snug slip fit into the bearing housing. Replace the bearings, shaft, or bearing housing if the proper bearing fit is not achieved.

Inspect the sleeve (27) and replace as necessary.

If bearing and sleeve replacement is required, remove the snap ring (24). Using a bearing puller, remove the bearing (25) from the drive pinion. Remove the sleeve and pull the bearing (28) from the shaft.

NOTE

It is not necessary to remove the snap ring (29) unless replacement is required. Use snap ring pliers to remove the ring.

Inspect the pinion bushing (18) for excessive wear. If replacement is required, use a bearing puller or similar device to remove the bushing from the bearing housing.

Slide the pinion shaft (32) and gear (15) out of the pinion bearing (33). Remove the spacer washer (31).

Inspect the pinion shaft and gear for wear or broken teeth. If replacement is required, use an arbor (or hydraulic) press to remove the shaft from the gear.

Use an arbor (or hydraulic) press, to remove the pinion bearing from the gear housing.

NOTE

It is not necessary to remove the drive shaft (36), drive gear (11), shaft bearing (4) or eccentric cam (34) unless wear or damage is obvious. Inspect the parts, and if replacement is necessary, proceed as follows:

Remove the snap ring (38) from the drive shaft. Using a bearing puller, remove the eccentric cam and key (37) from the drive shaft. Remove the eccentric cam shim set (35) and washer (39). Tie and tag the shims or measure and record their thickness for ease of reassembly.

Slide the drive shaft and gear out of the gear housing. Slide the spacer washer (5) off the drive shaft.

Remove the snap ring (13). Use an arbor (or hydraulic) press to remove the gear (11) and key (12) from the shaft.

To remove the drive shaft bearings (4 and 40), the spacer sleeve (2) must be coiled into a smaller diameter to allow passage through the I.D. of the bearings.

NOTE

After the spacer sleeve is compressed, it will be permanently damaged and require replacement.

To remove the spacer sleeve, remove the capscrew (3) and use a pointed tool to rotate the perforated steel sleeve until the seam is visible through the tapped hole. Apply pressure on one side of the seam until one edge overlaps the other. Reach through the I.D. of the bearings and continue to coil the spacer sleeve until it can be removed. Reinstall the capscrew (3).

Use an arbor (or hydraulic) press to remove the bearings (4 and 40) from the gear housing.

It is not necessary to remove the locating pins (17) from the gear housing unless they are bent or damaged. If replacement is required, press the pins from the housing.

Gearbox Reassembly And Installation

(Figure 4)

Inspect the shaft for distortion, nicks or scratches. Dress small nicks and burrs with a fine file or emery cloth. Replace the shaft if defective.

NOTE

*The needle bearings (4, 33 and 40) should **not** be heated. These bearings are designed to be pressed into the gear housing, not onto the shafts (32 and 36).*



To prevent damage during removal from the shaft, it is recommended that bearings be cleaned and inspected **in place**. It is **strongly** recommended that the bearings be replaced **any** time the shaft and bearings are removed.

The bearings may be heated to ease installation. An induction heater, hot oil bath, electric oven, or hot plate may be used to heat the bearings. Bearings should **never** be heated with a direct flame or directly on a hot plate.

NOTE

*If a hot oil bath is used to heat the bearings, both the oil and the container must be **absolutely** clean. If the oil has been previously used, it must be **thoroughly** filtered.*

Heat the bearings to a uniform temperature **no higher than 250°F (120°C)**, and slide the bearings onto the shaft, one at a time, until they are fully seated. This should be done quickly, in one continuous motion, to prevent the bearings from cooling and sticking on the shaft.



Use caution when handling hot bearings to prevent burns.

After the bearings have been installed and allowed to cool, check to ensure that they have not moved out of position in shrinking. If movement has occurred, use a suitable sized sleeve and a press to reposition the bearings.

If heating the bearings is not practical, use a suitable sized sleeve and an arbor (or hydraulic) press to install the bearings on the shaft.



When installing the bearings onto the shaft, **never** press or hit against the outer race,

balls, or ball cage. Press **only** on the inner race.

If removed, install the snap ring (29) in the groove on the pinion drive shaft (26). Install the bearing (28) on the pinion drive shaft against the snap ring. Install the sleeve (27). Install the bearing (25) onto the pinion drive shaft until squarely seated against the sleeve. Secure the bearing with the snap ring (24). Wrap the shaft and bearings in a clean cloth until reassembly in the bearing housing.

Install the bearing (40) in the gear housing until it is flush with the outer machined face of the housing. Install a new spacer sleeve (2) through the open bearing bore, and then press the bearing (4) into the bore until it is flush with the inner machined face on the housing.



When installing the bearings into the bearing bore, push against the outer race. **Never** hit the balls or ball cage.

Install the gear key (12) on the drive shaft (36). Press the drive gear (11) onto the drive shaft and secure with the snap ring (13). **Be sure** the drive gear seats against the snap ring.

Install the washer (5) onto the drive shaft and slide the assembled drive shaft and gear through the bearings in the gear housing. Install the same thickness of shims (35) as previously removed. Install the washer (39) and drive shaft key (37). Press the eccentric cam (34) onto the shaft and secure with the snap ring (38).

Press the pinion bearing (33) into the gear housing until the closed end is flush with the outer face of the bore.

Press the internal gear (15) onto the pinion shaft until it seats squarely against the pinion shoulder. Position the spacer washer (31) in the gear housing and slide the pinion shaft through the washer into the pinion bearing.

Press the pinion bushing (18) into the bearing housing until fully seated.

Slide the assembled pinion drive shaft and bearings into the bearing housing (16) until the bearing (28) is fully seated against the bore shoulder.

Press the oil seal (23) into the adaptor (22) with the lip positioned as shown in Figure 4. The outer face of the oil seal should be just flush with the face of the adaptor.

Install the washer (19) in the bearing housing, and press the oil seal assembly (21) into the bearing housing until fully seated. **Be careful** not to damage the oil seal lip on the pinion keyway.

Install the bearing housing gasket (14), and secure the cover plate (7) to the bearing housing with two of the capscrews and lockwashers (8 and 9).

If the locating pins (17) were removed, press them into the gear housing (1). Install the housing gasket (6), and position the bearing housing and cover plate against the gearing housing so that the locating pins align with the holes in the cover plate. Be sure the teeth on the drive pinion (26) mesh with those on the internal gear (15). Tap against the bearing housing with a soft-faced mallet or wood block until the pinion bushing (18) fully engages the pinion shaft (32).

Secure the cover plate to the gear housing with the remaining attaching hardware (8, 9 and 10).

NOTE

The two longer capscrews (10) must be installed in the two lower holes in the gear housing.

Install the drive key (20) in the drive pinion.

(Figure 1)

Install the coupling half (12) on the drive pinion (26, Figure 4).

Secure the gearbox assembly (8) to the diaphragm ring (36) with the hardware (24 and 25). Connect the coupling halves and check alignment as described in Section B.

Secure the coupling guard (11) to the base with hardware (22 and 23).

Lubricate the gearbox as described in **LUBRICATION**.

Plunger Rod Reassembly And Installation

(Figure 3)

Clean the bore of the eccentric cap (1) with a cloth soaked in cleaning solvent.



Most cleaning solvents are toxic and flammable. Use them only in a well-ventilated area free from excessive heat, sparks, and flame. Read and follow all precautions printed on solvent containers.

Press the eccentric bearing (2) into the cap with an arbor (or hydraulic) press.

Slide the plunger rod (15) through the upper diaphragm plate (9). Install the flat washer (8), spring (7), spring washer (6) adjusting shims (5) and jam nut (4). Compress the spring to the dimension shown in Figure 3) by tightening the jam nut.

Install the T-type lockwasher (3). Apply 'Loctite #242 Threadlocker on the plunger rod thread, and screw the eccentric cap on until tight.

NOTE

The lubrication fitting (16) in the diaphragm plate must face the same direction as the lubrication fitting (17) in the eccentric cap.

Lubricate the eccentric bearing (2) with a thin coating of No.2 lithium base grease.

Diaphragm Installation

(Figure 3)

Position the diaphragm (10) on the upper diaphragm plate, making sure the lip is properly seated. Slide the studs (13) in the lower diaphragm plate through the holes in the upper plate and secure with the nuts (14).

(Figure 1)

Install the plunger rod assembly (26) onto the eccentric cam (34), Figure 4). Secure with the snap ring (6).

Install the eccentric guard (1), and secure with the hardware (2, 3, 4, 43, 44 and 45).

Lubricate the plunger rod assembly as described in **LUBRICATION**, Section E.

Secure the diaphragm pot assembly (34) to the diaphragm ring (36) with the hardware (32 and 33).

Suction And Discharge Flap Valve Installation (Figure 2)

Inspect the flap valve components and replace as required. Subassemble the flap valve weights (28, 31, 34 and 37) and flap valves (32 and 38) with the hardware (29, 30, 35 and 36).

If the inboard discharge flange (24) was removed, clean the mating surfaces and install the gasket (20). Secure the flange to the diaphragm pot with the hardware (22 and 23).

Subassemble the valve seat (26) and discharge flap valve (27) to the discharge flange (1) with the weights positioned as shown in Figure 2. Secure with the hardware (3 and 4). Check the operation of the flap valve to ensure proper seating and free movement.

Clean the mating surfaces of the valve seat and discharge flange (24). Install the gasket (25) and secure the discharge flanges with the hardware (5 and 6).

Subassemble the suction flap valve (33), gasket (17) and valve seat (16) to the diaphragm pot (19) with the weights positioned as shown in Figure 2. Secure with the hardware (8 and 9).

Check the operation of the flap valve to ensure proper seating and free movement. Secure the suction accumulator (11) to the diaphragm pot with the hardware (14 and 15).

Connect the suction and discharge piping as described in **INSTALLATION**, Section B.

Refer to **OPERATION**, Section C before starting the pump.

LUBRICATION

Plunger Rod Assembly

(Figure 3)



The eccentric bearing should be lubricated thoroughly after each 8 hours of operation. Failure to do so may cause the bearing to overheat and fail.

Before attempting to lubricate the plunger rod assembly, set the engine control on the stop position. Use the engine pull rope to rotate the eccentric cam until the grease fittings (16 and 17) can be accessed through the holes in the eccentric guard (1, Figure 1).

Apply No. 2 lithium base grease to the upper lubrication fitting until grease escapes from the eccentric cap. Lubricate the lower fitting until grease escapes from the top of the upper diaphragm plate inside the spring.

Gearbox

(Figure 4)

The gearbox was fully lubricated when shipped from the factory. Check the oil level regularly at the oil cup (30), and keep the oil cup full. Lubricate with SAE No. 30 non-detergent when lubrication is required. **Do not** over-lubricate. Over lubrication can cause the bearings to overheat resulting in premature bearing failure.

Under normal conditions, drain the gearbox once each year. Change the oil more frequently if the pump is operated continuously or installed in an environment with rapid temperature change.



Monitor the condition of the bearing lubricant regularly for evidence of rust or moisture condensation. This is especially important in areas where variable hot and cold temperatures are common.

When lubricating a dry (or overhauled) gearbox, add one ounce of 'Molykote M Gear Guard' and 'top off' with clean oil.

For cold weather operation, consult the factory or a lubricant supplier for the recommended grade of oil.

Engine

(Figure 1)

Refer to the engine manufacturer's recommendations or contact your local Lombardini engine representative.

**For U.S. and International Warranty Information,
Please Visit www.grpumps.com/warranty
or call:
U.S.: 419-755-1280
International: +1-419-755-1352**

**For Canadian Warranty Information,
Please Visit www.grcanada.com/warranty
or call:
519-631-2870**