

---

**INSTALLATION, OPERATION,  
AND MAINTENANCE MANUAL**  
WITH PARTS LIST



**0 SERIES PUMPS**

MODEL
<b>04E1-GA</b>

**THE GORMAN-RUPP COMPANY • MANSFIELD, OHIO**  
GORMAN-RUPP OF CANADA LIMITED • ST. THOMAS, ONTARIO, CANADA Printed in U.S.A.



# TABLE OF CONTENTS

<b>INTRODUCTION</b> .....	<b>PAGE I - 1</b>
<b>SAFETY - SECTION A</b> .....	<b>PAGE A - 1</b>
<b>INSTALLATION - SECTION B</b> .....	<b>PAGE B - 1</b>
Pump Dimensions .....	PAGE B - 1
<b>PREINSTALLATION INSPECTION</b> .....	<b>PAGE B - 1</b>
<b>VEHICLE REQUIREMENTS</b> .....	<b>PAGE B - 2</b>
Tank Preparation .....	PAGE B - 2
<b>POSITIONING PUMP</b> .....	<b>PAGE B - 2</b>
Lifting .....	PAGE B - 2
<b>ALIGNMENT</b> .....	<b>PAGE B - 3</b>
<b>SUCTION AND DISCHARGE PIPING</b> .....	<b>PAGE B - 4</b>
Typical System Installation .....	PAGE B - 4
Piping .....	PAGE B - 5
Sealing .....	PAGE B - 5
Valves .....	PAGE B - 5
Siphoning .....	PAGE B - 6
Eductors .....	PAGE B - 6
<b>OPERATION - SECTION C</b> .....	<b>PAGE C - 1</b>
<b>PRIMING</b> .....	<b>PAGE C - 1</b>
<b>GROUNDING</b> .....	<b>PAGE C - 1</b>
<b>STARTING</b> .....	<b>PAGE C - 1</b>
Rotation .....	PAGE C - 1
Drive .....	PAGE C - 2
<b>OPERATION</b> .....	<b>PAGE C - 2</b>
Leakage .....	PAGE C - 2
Liquid Temperature And Overheating .....	PAGE C - 2
Strainer Check .....	PAGE C - 2
Pump Vacuum Check .....	PAGE C - 2
<b>STOPPING</b> .....	<b>PAGE C - 3</b>
Cold Weather Preservation .....	PAGE C - 3
<b>GEARBOX TEMPERATURE CHECK</b> .....	<b>PAGE C - 3</b>
<b>TROUBLESHOOTING - SECTION D</b> .....	<b>PAGE D - 1</b>
<b>PUMP MAINTENANCE AND REPAIR - SECTION E</b> .....	<b>PAGE E - 1</b>
<b>PERFORMANCE CURVES</b> .....	<b>PAGE E - 1</b>
<b>PARTS LIST:</b>	
Pump Model .....	PAGE E - 3
<b>PUMP AND SEAL DISASSEMBLY AND REASSEMBLY</b> .....	<b>PAGE E - 4</b>
Removing Pump and Gearbox .....	PAGE E - 4
Suction Head and Wear Ring Removal .....	PAGE E - 5
Impeller Removal And Pump Casing Wear Ring Removal .....	PAGE E - 5
Seal Removal and Disassembly .....	PAGE E - 5
Pump Casing Removal .....	PAGE E - 5

**TABLE OF CONTENTS**  
**(continued)**

<b>PUMP AND SEAL REASSEMBLY</b> .....	<b>PAGE E - 6</b>
Pump Casing Installation .....	<b>PAGE E - 6</b>
Seal Reassembly and Installation .....	<b>PAGE E - 6</b>
Impeller And Pump Casing Wear Ring Installation .....	<b>PAGE E - 8</b>
Suction Head and Wear Ring Installation .....	<b>PAGE E - 9</b>
Installing Pump and Gearbox .....	<b>PAGE E - 9</b>
<b>GEARBOX DISASSEMBLY</b> .....	<b>PAGE E - 9</b>
<b>GEARBOX REASSEMBLY</b> .....	<b>PAGE E - 10</b>
<b>LUBRICATION</b> .....	<b>PAGE E - 11</b>
Seal Assembly .....	<b>PAGE E - 11</b>
Gearbox .....	<b>PAGE E - 11</b>

## INTRODUCTION

This Installation, Operation, and Maintenance manual is designed to help you achieve the best performance and longest life from your Gorman-Rupp pump.

This pump is an 0 Series, enclosed impeller, centrifugal model, with straight-in suction and without a suction check valve. The pump is equipped with "Victaulic" suction and discharge fittings, and is designed for vehicular mounting in water or petroleum

service. The basic material of construction for wetted parts is aluminum, with cast iron wearing parts.

The pump is close-coupled to an integral speed increaser with a 2.19:1 input ratio, with a maximum input speed of 2250 RPM. Power is transmitted to the gearbox through a customer-installed universal shaft assembly.

If there are any questions regarding the pump or its application which are not covered in this manual or in other literature accompanying this unit, please contact your Gorman-Rupp distributor, or write:

**The Gorman-Rupp Company**  
P.O. Box 1217  
Mansfield, Ohio 44901-1217

or

**Gorman-Rupp of Canada Limited**  
70 Burwell Road  
St. Thomas, Ontario N5P 3R7

For information or technical assistance on the power source, contact the power source manufacturer's local dealer or representative.

The following are used to alert maintenance personnel to procedures which require special attention, to those which could damage equipment, and to those which could be dangerous to personnel:



**Immediate hazards which WILL result in severe personal injury or death. These instructions describe the procedure required and the injury which will result from failure to follow the procedure.**



**Hazards or unsafe practices which COULD result in severe personal injury or death. These instructions describe the procedure required and the injury which could result from failure to follow the procedure.**



Hazards or unsafe practices which COULD result in minor personal injury or product or property damage. These instructions describe the requirements and the possible damage which could result from failure to follow the procedure.

### NOTE

*Instructions to aid in installation, operation, and maintenance or which clarify a procedure.*



### SAFETY – SECTION A

This information applies to 0 Series power take-off pumps. Refer to the manual accompanying the vehicle before attempting to begin operation.



Before attempting to open or service the pump:

1. Familiarize yourself with this manual.
2. Switch off the vehicle ignition and remove the key to ensure that the pump will remain inoperative.
3. Allow the pump to cool if overheated.
4. Check the temperature before opening any covers, plates, or plugs.
5. Close the suction and discharge valves.
6. Vent the pump slowly and cautiously.
7. Drain the pump.



This pump is designed for vehicular mounting in water or petroleum service. Do not attempt to pump corrosive materials, or any liquids which may damage the pump or endanger personnel as a result of pump failure.



If this pump is used with volatile and/or flammable liquids, be certain proper safety practices are followed before op-

erating or servicing the pump. Provide adequate ventilation, prohibit smoking, wear static-resistant clothing and shoes. Clean up all fuel spills immediately after occurrence.



Use lifting and moving equipment in good repair and with adequate capacity to prevent injuries to personnel or damage to equipment. Suction and discharge hoses and piping must be removed from the pump before lifting.



After the pump has been positioned, make certain that the pump and all piping connections are tight, properly supported and secure before operation.



Do not operate the pump without the guards in place over the rotating parts. Exposed rotating parts can catch clothing, fingers, or tools, causing severe injury to personnel.



Do not operate the pump against a closed discharge valve for long periods of time. If operated against a closed discharge valve, pump components will deteriorate, and the liquid could come to a boil, build pressure, and cause the pump casing to rupture or explode.



If this pump is used with volatile and/or flammable liquids, overheating may produce dangerous fumes. Take precautions to ensure the area surrounding the pump is adequately ventilated. Allow the pump to cool and use extreme caution when venting the pump, or when removing covers, plates, plugs, or fitting.



Allow an overheated pump to cool before servicing. Do not remove plates, covers, gauges, pipe plugs, or fittings from an overheated pump. Liquid within the pump can reach boiling temperatures, and vapor pressure within the pump can cause parts being disengaged to be ejected with great force. After the pump cools, drain the liquid from the pump by removing the casing drain plug. Use caution when removing the plug to prevent injury to personnel from hot liquid.



**Never run this pump backwards. Be certain that rotation is correct before fully engaging the pump.**



After the vehicle is positioned for pump maintenance, block the wheels and set the emergency brake before attempting to disconnect the drive shaft or remove the pump. Be sure the pump is properly reinstalled and secure before operation.



Never tamper with the governor to gain more power. The governor establishes safe operating limits that should not be exceeded. Limit the maximum input speed and operation range as indicated on the performance curves on Page E-1.



The gearbox provided on this pump is designed for operation at 2250 RPM maximum input speed. If operated at a higher RPM, pump components may be destroyed.



Never run the pump dry of pumping medium. There must be a supply of liquid to the pump at all times to prevent destruction of the shaft seal faces.



## INSTALLATION – SECTION B

### Review all SAFETY Information In Section A.

Since pump installations are seldom identical, this section offers only general recommendations and practices required to inspect, position, and arrange the pump and piping.



**Do not test or operate your pump and integral gearbox before reading the installation and operation instructions in this manual.**

This pump is a self-priming centrifugal model with an integral speed increasing gearbox assembly. The pump is designed for vehicular mounting in water or petroleum service, where the liquid is supplied to the pump under pressure. Since the pressure supplied to the pump is critical to performance and

safety, be sure to limit the incoming pressure to 50% of the maximum permissible operating pressure as shown on the pump performance curve (see Section E, Page 1).

The integral gearbox is designed to be driven through the vehicle transfer case by a customer-supplied universal shaft assembly. The pump casing or gearbox may be rotated in 45° increments to assist with alignment with the vehicle tank; however, if the gearbox is to be rotated, some modifications must be made to the gearbox to ensure adequate lubrication. Consult the factory for details.

For further assistance, contact your Gorman-Rupp distributor or the Gorman-Rupp Company.

### Pump Dimensions

See Figure 1 for the approximate physical dimensions of this pump.

### OUTLINE DRAWING

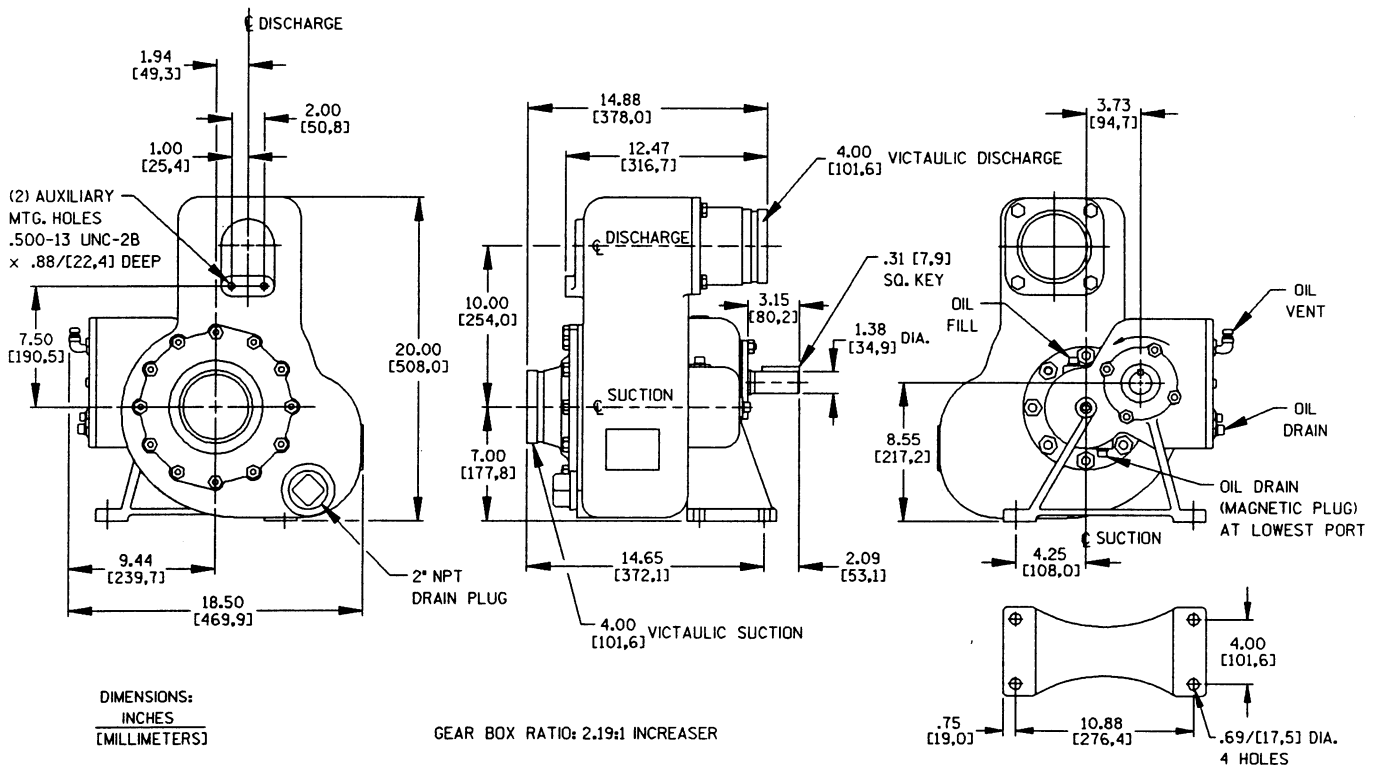

**Figure 1. Pump Model 04E1-GA**

### PREINSTALLATION INSPECTION

The pump assembly was inspected and tested before shipment from the factory. Before installation,

inspect the pump for damage which may have occurred during shipment. Check as follows:

- a. Inspect the pump and gearbox for cracks, dents, damaged threads, and other obvious damage.
- b. Check for and tighten loose attaching hardware. Since gaskets tend to shrink after drying, check for loose hardware at mating surfaces.
- c. Carefully read all tags, decals, and markings on the pump assembly, and perform all duties indicated. Note the direction of rotation indicated on the pump. Check that the pump shaft rotates in the required direction.



Only operate this pump in the direction indicated on the pump body and/or the accompanying decal. Reverse rotation of the shaft will adversely effect pump performance, and the pump and/or gearbox could be seriously damaged.

- d. Check levels and lubricate as necessary. Refer to **LUBRICATION** in the **MAINTENANCE AND REPAIR** section of this manual and perform duties as instructed.
- e. If the pump and gearbox have been stored for more than 12 months, some of the components or lubricants may have exceeded their maximum shelf life. These **must be inspected or replaced** to ensure maximum pump service.

If the maximum shelf life has been exceeded, or if anything appears to be abnormal, contact your Gorman-Rupp distributor or the factory to determine the repair or updating policy. **Do not** put the pump into service until appropriate action has been taken.

## VEHICLE REQUIREMENTS

The following instructions apply equally to new installations, rebuilds or retrofits.

### Tank Preparation

It is **essential** that any tank scale, dirt, or other foreign material be removed from the tank and piping

prior to pump installation. Failure to do so could result in clogging or damage to the pump.



Damage to the pump resulting from debris in the suction line **will not** be covered by the pump warranty.

Before connecting the suction and discharge piping, carefully check the storage tank and piping for construction debris such as nuts, bolts, wire, weld slag, and other foreign material. Install a commercially available 80 mesh screen in the suction line to prevent debris from entering the pump.

## POSITIONING PUMP

### Lifting

Use lifting equipment with a capacity of at least **650 pounds (295 kg.)**. This pump weighs approximately **124 pounds (56 kg.)**, not including the weight of piping or customer-accessories.



The pump assembly can be seriously damaged if the cables or chains used to lift and move the unit are improperly wrapped around the pump.

Due to the confined mounting location, specialized equipment such as a transmission jack with custom brackets should be used to lift and position the pump and gearbox.

### NOTE

*If the gearbox is rotated out of the standard position shown in Figure 1, the oil fill and drain plugs must be relocated. The magnetic drain plug must be relocated to the lowest port, and the oil vent and elbow must be relocated to the highest port. Consult the factory for correct positioning of the fill plug to provide for proper lubrication of the gearbox.*

**ALIGNMENT**



**When installing and/or aligning universal shaft assemblies, switch off the vehicle ignition and remove the key to ensure that the pump will remain inoperative.**

The alignment of the pump and its power source is critical for trouble-free mechanical operation. Before checking alignment, make sure that the gearbox mounting bolts are tight.

When connecting the universal joint drive shaft assembly to a PTO unit, install, support, and align the drive shaft in accordance with the manufacturer's instructions. The pump and the drive power source are generally positioned so that shaft centerlines are

parallel and horizontal. The maximum operating angle should not exceed 15 degrees (see Figure 2).

Check the direction of rotation of the PTO unit before starting the pump. The drive shaft must rotate in the direction shown on the body of the pump, gearbox, and/or decals, tags, and labels.



**Do not operate the pump without the guard in place over the rotating parts. Exposed rotating parts can catch clothing, fingers, or tools, causing severe injury to personnel.**

After the power take-off has been aligned, block the wheels of the external power source, engage the braking system, or take other precautions to ensure that the power source will remain stationary. Block the wheels on the unit to prevent creeping.

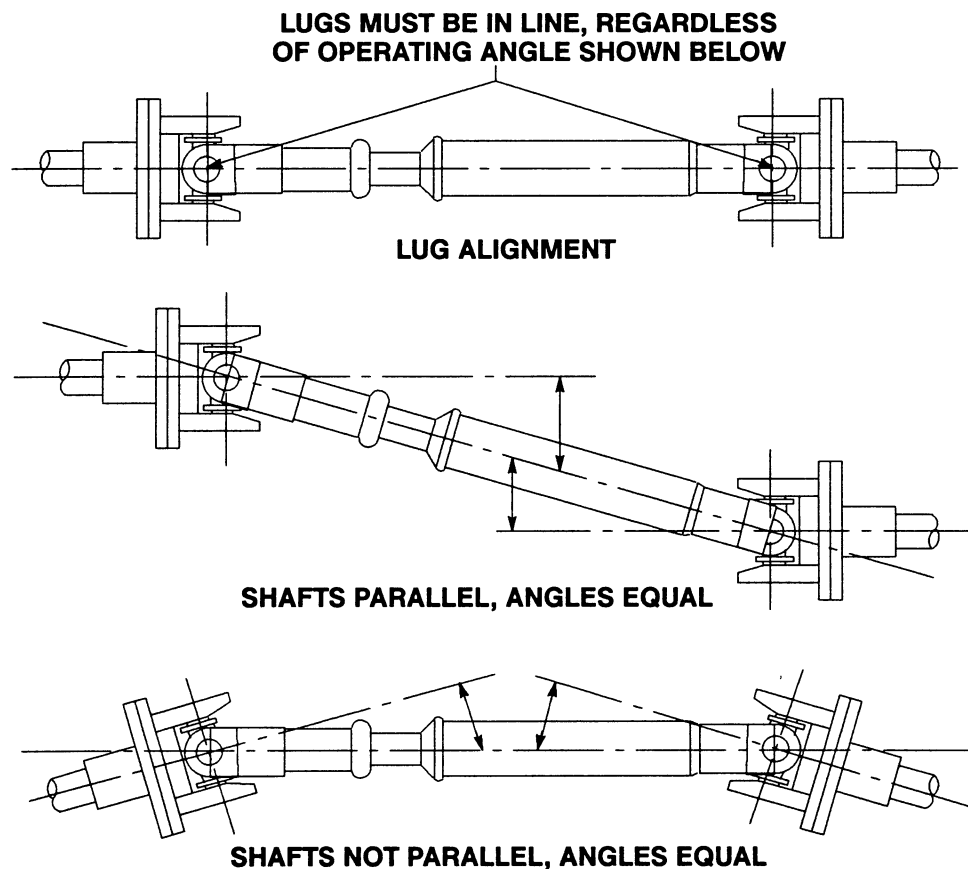

**Figure 2. Proper Installation And Alignment of Universal Assembly**

**SUCTION AND DISCHARGE PIPING**

related piping and safety accessories. Some of the accessories are available from Gorman-Rupp as optional equipment.

**Typical System Installation**

Tank filling and dispensing operations require a system utilizing flow-directing (FDF) valves, eductors,

Refer to Figures 3 and 4 for illustrations of typical piping systems for tank filling and dispensing.

**SCHEMATIC SYSTEM USING EDUCTOR FOR DISPENSING AND FILLING**

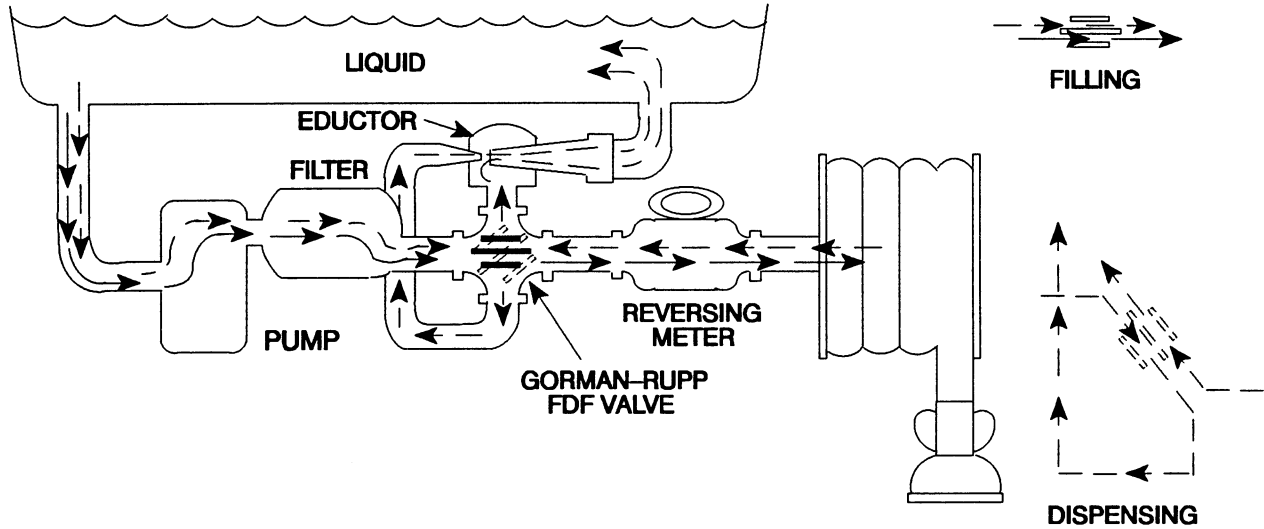

**Figure 3. Typical System Installation Using Educator For Filling And Dispensing**

**SCHEMATIC SYSTEM USING PUMP FOR DISPENSING AND FILLING**

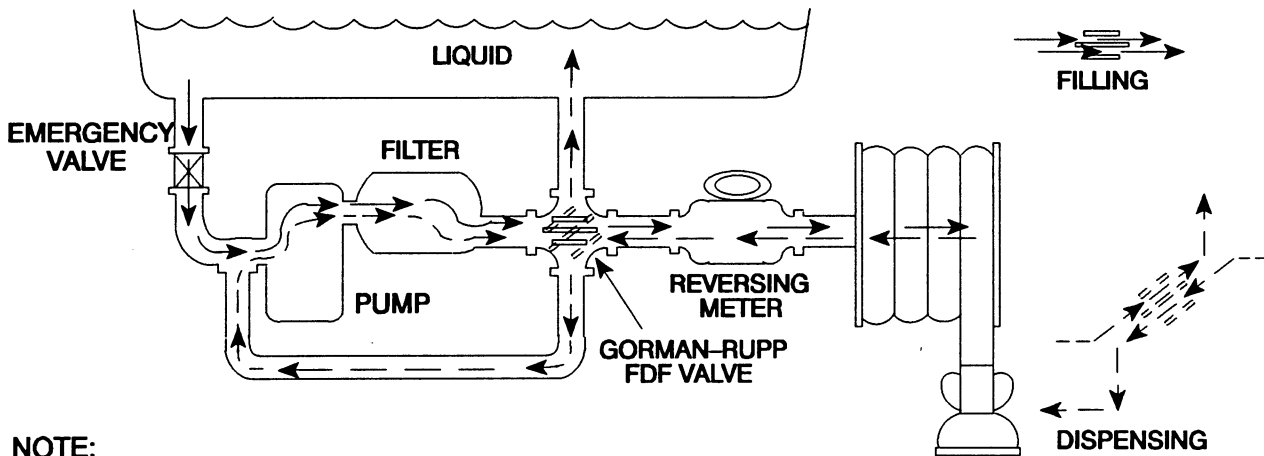

**NOTE:**  
 EMERGENCY VALVE OPEN FOR FILLING  
 EMERGENCY VALVE CLOSED FOR DISPENSING

**Figure 4. Typical Installation Using Pump For Filling And Dispensing**

## Piping

All piping material must be compatible with the liquid being pumped. If hose is used in suction lines, it must be the rigid-wall, reinforced type to prevent collapse under suction. Using piping couplings in suction lines is not recommended.

A suction strainer was not furnished with this pump since it is **not** designed to handle liquids containing solids. However, to protect the pump from accidental damage a commercially available 80 mesh screen should be installed in the suction line. Make certain that the total open area of the screen is at least three or four times the cross section of the suction line to ensure an adequate supply of liquid to the pump.



Damage to the pump resulting from debris in the suction line **will not** be covered by the pump warranty.

Before connecting the suction and discharge piping, carefully check the storage tank and piping for construction debris such as nuts, bolts, wire, weld slag, and other foreign material. Install a commercially available 80 mesh screen in the suction line to prevent debris from entering the pump.

If a throttling valve is desired in the discharge line, use a valve as large as the largest pipe to minimize

friction losses. Never install a throttling valve in a suction line.

With high discharge heads, it is recommended that a throttling valve and a system check valve be installed in the discharge line to protect the pump from excessive shock pressure and reverse rotation when it is stopped.

## Sealing

Since even a slight leak will affect priming, head, and capacity, especially when operating with a high suction lift, all connections in the suction line should be sealed with pipe dope to ensure an airtight seal. Follow the sealant manufacturer's recommendations when selecting and applying the pipe dope.

## Valves

Gorman-Rupp manufactures several sizes of flow-diverting (FDF) valves for use in truck-mounted pumping applications. The valves are designed to reverse the flow of liquid with only the turn of a handle. This allows the same pump to fill or dispense from the tank.



The FDF valve is designed for directing flow only. It will not serve as a positive shutoff or throttling valve.

See Figure 5 illustrating the theory of operation for a typical FDF valve. Consult the factory for further assistance or other sizes.

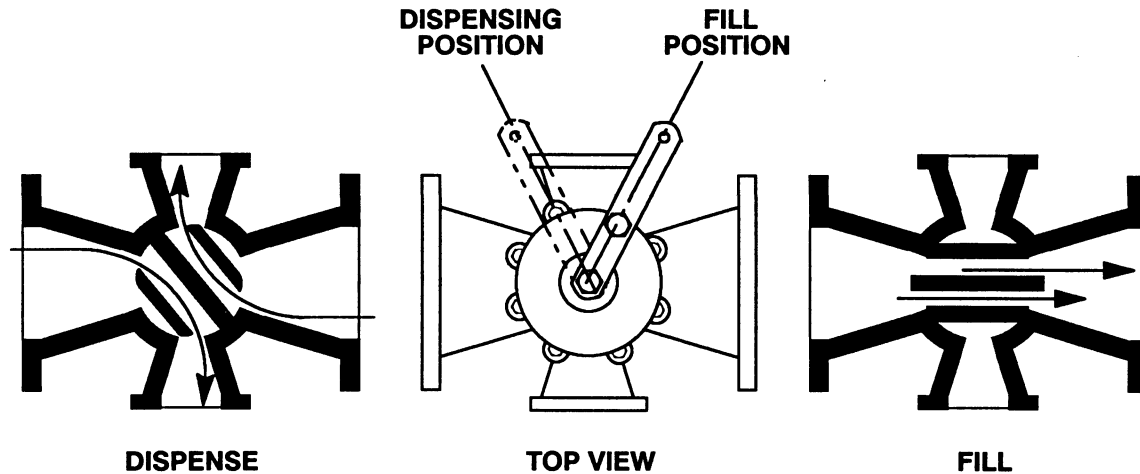

**Figure 5. FDF Valve Theory of Operation**

When the center web of the valve is aligned with the larger ports (filling position), the flow passes straight through. When the handle is turned to the dispensing position, the web blocks the straight flow and opens two paths of flow through the larger ports to the smaller ports.

#### **Siphoning**

Do not terminate the discharge line at a level lower than that of the liquid being pumped unless a siphon breaker is used in the line. Otherwise, a siphoning action causing damage to the pump could result.

#### **Eductors**

An eductor may be used in conjunction with an FDF valve to increase dispensing rates and improve efficiency. An eductor may also be used to collapse the tank service hose after the tank has been filled or emptied.

Contact the Gorman-Rupp Company or an authorized distributor for specifications and performance data on eductors or FDF valves.

## OPERATION – SECTION C

Review all SAFETY information in Section A.

Follow the instructions on all tags, labels and decals attached to the pump.



This pump is designed for vehicular mounting in water or petroleum service. Do not attempt to pump corrosive materials, or any liquids which may damage the pump or endanger personnel as a result of pump failure.



The gearbox provided on this pump is designed for operation at 2250 RPM maximum input speed. If operated at a higher RPM, pump components may be destroyed.

### PRIMING

Install the pump and piping as described in **INSTALLATION**. Make sure that the piping connections are tight, and that the pump is securely mounted. Check that the pump is properly lubricated (see **LUBRICATION** in **MAINTENANCE AND REPAIR**).

This pump is self-priming, but the pump should never be operated unless there is liquid in the pump casing.



Never operate this pump unless there is liquid in the pump casing. The pump will not prime when dry. Extended operation of a dry pump will destroy the seal assembly.

Add liquid to the pump casing when:

1. The pump is being put into service for the first time.
2. The pump has not been used for a considerable length of time.
3. The liquid in the pump casing has evaporated.

When installed in a flooded suction application, simply open the system valves and permit the incoming liquid to evacuate the air. After the pump and piping system have completely filled, evacuate any remaining air pockets in the pump or suction line by loosening a pipe plug or opening bleeder valves.

Once the pump casing has been filled, the pump will prime and reprime as necessary.

### GROUNDING

To eliminate electrostatic build-up when pumping petroleum products, the pump must be grounded by attaching a ground wire to a ground rod (grounding is not required when pumping water). Install the ground rod in accordance with the National Electric Code and all local codes. Be sure the clamp or fastener has made a tight electrical connection with the rod.



Inspect and test the ground wire assembly for conductivity. Replace broken or frayed wire before resuming operation.

### STARTING

Consult the operations manual furnished with the vehicle.

#### Rotation

The correct direction of pump rotation is counterclockwise when facing the input shaft. The pump could be damaged and performance adversely af-

ected by incorrect rotation. If pump performance is not within the specified limits (see the curve on Page E-1), check the direction of rotation before further troubleshooting.

### Drive

This pump is designed for operation with a power take-off unit coupled to the drive shaft on the gearbox. The gearbox assembly has a ratio of 2.19:1, and is designed for operation at 2250 RPM maximum input speed. **Do not** operate at a higher input speed.



The gearbox provided on this pump is designed for operation at 2250 RPM maximum input speed. If operated at a higher RPM, pump components may be destroyed.

## OPERATION

Partially open the discharge throttling valve so that the discharge line fills slowly to prevent damage to piping, gaskets, and other devices in the line which could be affected by shock resulting from rapid filling of the line. When the discharge line is completely filled, adjust the discharge throttling valve to the desired flow rate.

### Leakage

No leakage should be visible at pump mating surfaces, or at pump connections or fittings. Keep all line connections and fittings tight to maintain maximum pump efficiency.

### Liquid Temperature And Overheating

The **maximum** liquid temperature for this pump is 160° F (71 °C). Do not apply it at a higher operating temperature.

Overheating can occur if operated with the valves in the suction or discharge lines closed. Operating against closed valves could bring the liquid to a boil, build pressure, and cause the pump to rupture or ex-

plode. If overheating occurs, stop the pump and allow it to cool before servicing it. Refill the pump casing with cool liquid.



**Allow an overheated pump to cool before servicing. Do not remove plates, covers, gauges, pipe plugs, or fittings from an overheated pump. Liquid within the pump can reach boiling temperatures, and vapor pressure within the pump can cause parts being disengaged to be ejected with great force. After the pump cools, drain the liquid from the pump by removing the casing drain plug. Use caution when removing the plug to prevent injury to personnel from hot liquid.**

### Strainer Check

If a suction strainer has been shipped with the pump or installed by the user, check the strainer regularly, and clean it as necessary. The strainer should also be checked if pump flow rate begins to drop. If a vacuum suction gauge has been installed, monitor and record the readings regularly to detect strainer blockage.

**Never** introduce air or steam pressure into the pump casing or piping to remove a blockage. This could result in personal injury or damage to the equipment. If backflushing is absolutely necessary, liquid pressure **must** be limited to 50% of the maximum permissible operating pressure shown on the pump performance curve (see Section E, Page 1).

### Pump Vacuum Check

Since this pump does not have a suction check valve, the discharge line must be fitted with a check valve if a pump vacuum reading is to be taken.

With the pump inoperative, install a vacuum gauge in the system, using pipe dope on the threads. Block the suction line and start the pump. At operating speed the pump should pull a vacuum of 15 to 17 inches (381 to 432 mm) or more of mercury when pumping petroleum, or 20 inches (508 mm) or more



of mercury when pumping water. If it does not, check for air leaks in the seal, gasket, or discharge valve.

Open the suction line, and read the vacuum gauge with the pump primed and at operation speed. Shut off the pump. The vacuum gauge reading will immediately drop proportionate to static suction lift, and should then stabilize. If the vacuum reading falls off rapidly after stabilization, an air leak exists. Before checking for the source of the leak, check the point of installation of the vacuum gauge.

### NOTE

*Petroleum products are very sensitive to changes in temperature. Warmer temperatures elevate the product vapor pressure, resulting in low vacuum readings. Do not mistake temperature problems for faulty pump installation or performance.*

## STOPPING

Never halt the flow of liquid suddenly. If the liquid being pumped is stopped abruptly, damaging shock waves can be transmitted to the pump and piping system. Close all connecting valves slowly.

On engine driven pumps, reduce the throttle speed slowly and allow the engine to idle briefly before stopping.



If the application involves a high discharge head, gradually close the discharge throttling valve before stopping the pump.

After stopping the pump, switch off the vehicle ignition and remove the key to ensure that the pump will remain inoperative.

### Cold Weather Preservation

If the application of this pump is limited to petroleum products, normal freezing conditions will not damage the pump. However, during extremely severe conditions care should be exercised during start-up, especially if the pump has been idle for more than a few hours.

When pumping water, drain the pump to prevent damage during freezing conditions.

## GEARBOX TEMPERATURE CHECK

The gearbox runs higher than ambient temperatures because of heat generated by friction. Temperatures of approximately 200°F (93°C) are considered normal, and can operate intermittently at 250°F (121°C).

Checking gearbox temperatures by hand is inaccurate. Place a contact-type thermometer against the housing and record this temperature for future reference.

A sudden increase in gearbox temperature is a warning that the bearings are at the point of failing. Make certain that the bearing lubricant is of the proper viscosity and at the correct level (see **LUBRICATION** in Section E). Bearing overheating can also be caused by shaft misalignment and/or excessive vibration.

When pumps are first started, the bearings may seem to run at temperatures above normal. Continued operation should bring the temperatures down to normal levels within 20 minutes or less.



## TROUBLESHOOTING – SECTION D

Review all SAFETY information in Section A.



**Before attempting to open or service the pump:**

- 1. Familiarize yourself with this manual.**
- 2. Switch off the vehicle ignition and remove the key, or take other precautions to ensure that the pump will remain inoperative.**
- 3. Allow the pump to cool if overheated.**
- 4. Check the temperature before opening any covers, plates, or plugs.**
- 5. Close the suction and discharge valves.**
- 6. Vent the pump slowly and cautiously.**
- 7. Drain the pump.**

TROUBLE	POSSIBLE CAUSE	PROBABLE REMEDY
PUMP FAILS TO PRIME	Not enough liquid in casing.  Air leak in suction line.  Lining of suction hose collapsed.  Leaking or worn seal or pump gasket.  Pump speed too slow.  Strainer clogged.	Add liquid to casing. See <b>PRIMING</b> .  Correct leak.  Replace suction hose.  Check pump vacuum. Replace leaking or worn seal or gasket.  Check driver output; consult vehicle operation manual.  Check strainer and clean if necessary.
PUMP STOPS OR FAILS TO DELIVER RATED FLOW OR PRESSURE	Air leak in suction line.  Suction intake not submerged at proper level or sump too small.  Strainer clogged.  Pump speed too slow.  Lining of suction hose collapsed.	Correct leak.  Check installation and correct submergence as needed.  Check strainer and clean if necessary.  Check driver output; consult vehicle operation manual.  Replace suction hose.

TROUBLE	POSSIBLE CAUSE	PROBABLE REMEDY
PUMP STOPS OR FAILS TO DELIVER RATED FLOW OR PRESSURE (cont.)	<p>Impeller or other wearing parts worn or damaged.</p> <p>Suction lift or discharge head too high.</p> <p>Pump speed too slow.</p> <p>discharge line clogged or restricted; hose kinked.</p>	<p>Replace worn or damaged parts. Check that impeller is properly centered and rotates freely.</p> <p>Check piping installation and install bypass line if needed. See <b>INSTALLATION</b>.</p> <p>Check power source output; consult power source operation manual.</p> <p>Check discharge lines; straighten hose.</p>
PUMP REQUIRES TOO MUCH POWER	<p>Universal drive misaligned.</p> <p>Pump speed too high.</p> <p>Discharge head too low.</p>	<p>Align drive.</p> <p>Check driver output.</p> <p>Adjust discharge valve.</p>
EXCESSIVE NOISE	<p>Cavitation in pump.</p> <p>Pumping entrained air.</p> <p>Pump or drive not securely mounted.</p> <p>Universal drive misaligned.</p> <p>Low or incorrect lubricant.</p>	<p>Reduce suction lift and/or friction losses in suction line. Record vacuum and pressure gauge readings and consult local representative or factory.</p> <p>Locate and eliminate source of air bubble.</p> <p>Secure mounting hardware.</p> <p>Align drive.</p> <p>Check for proper type and level of lubricant.</p>
BEARINGS RUN TOO HOT	<p>Bearing temperature is high, but within limits.</p> <p>Low or incorrect lubricant.</p> <p>Suction and discharge lines not properly supported.</p> <p>Drive misaligned.</p> <p>Bearings in power source or gearbox worn or binding.</p>	<p>Check bearing temperature regularly to monitor any increase.</p> <p>Check for proper type and level of lubricant.</p> <p>Check piping installation for proper support.</p> <p>Align drive properly.</p> <p>Check bearings.</p>

## PUMP MAINTENANCE AND REPAIR - SECTION E

**MAINTENANCE AND REPAIR OF THE WEARING PARTS OF THE PUMP WILL MAINTAIN PEAK OPERATING PERFORMANCE.**

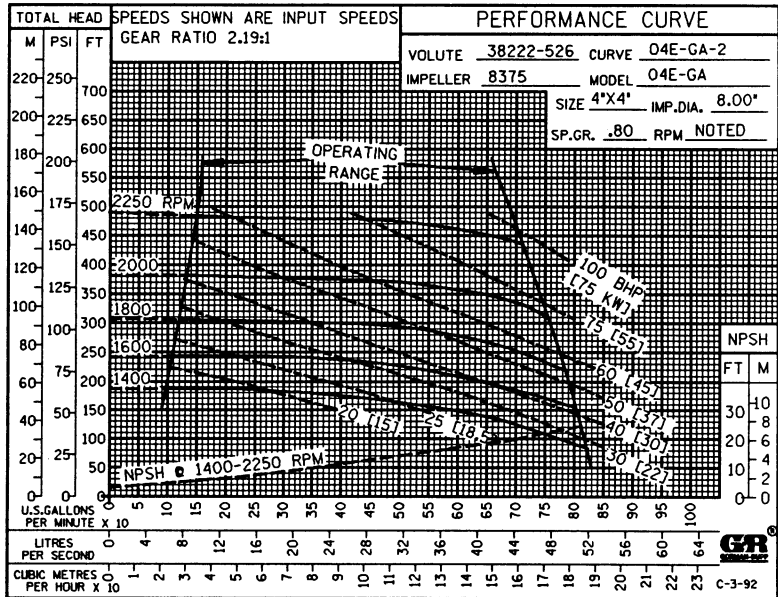
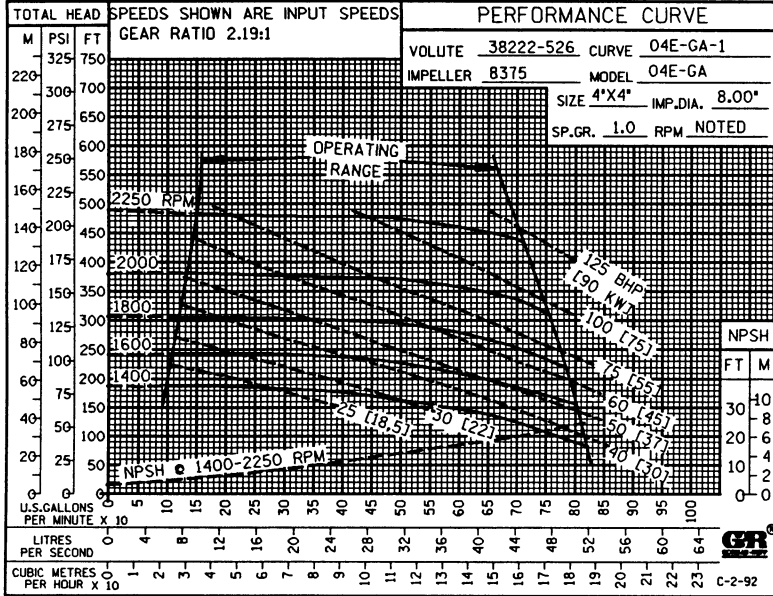

**\* STANDARD PERFORMANCE FOR PUMP MODEL 04E1-GA**

\* Based on 70° F (21° C) clear water (or corrected to 0.8 specific gravity) at sea level with minimum suction lift. Since pump installations are seldom identical, your performance may be different due to such factors as viscosity, specific gravity, elevation, temperature, and impeller trim.

Contact the Gorman-Rupp Company to verify part numbers.



Pump speed and operating condition points must be within the continuous performance range shown on the curve.

If your pump serial number is followed by an "N", your pump is NOT a standard production model.

SECTION DRAWING

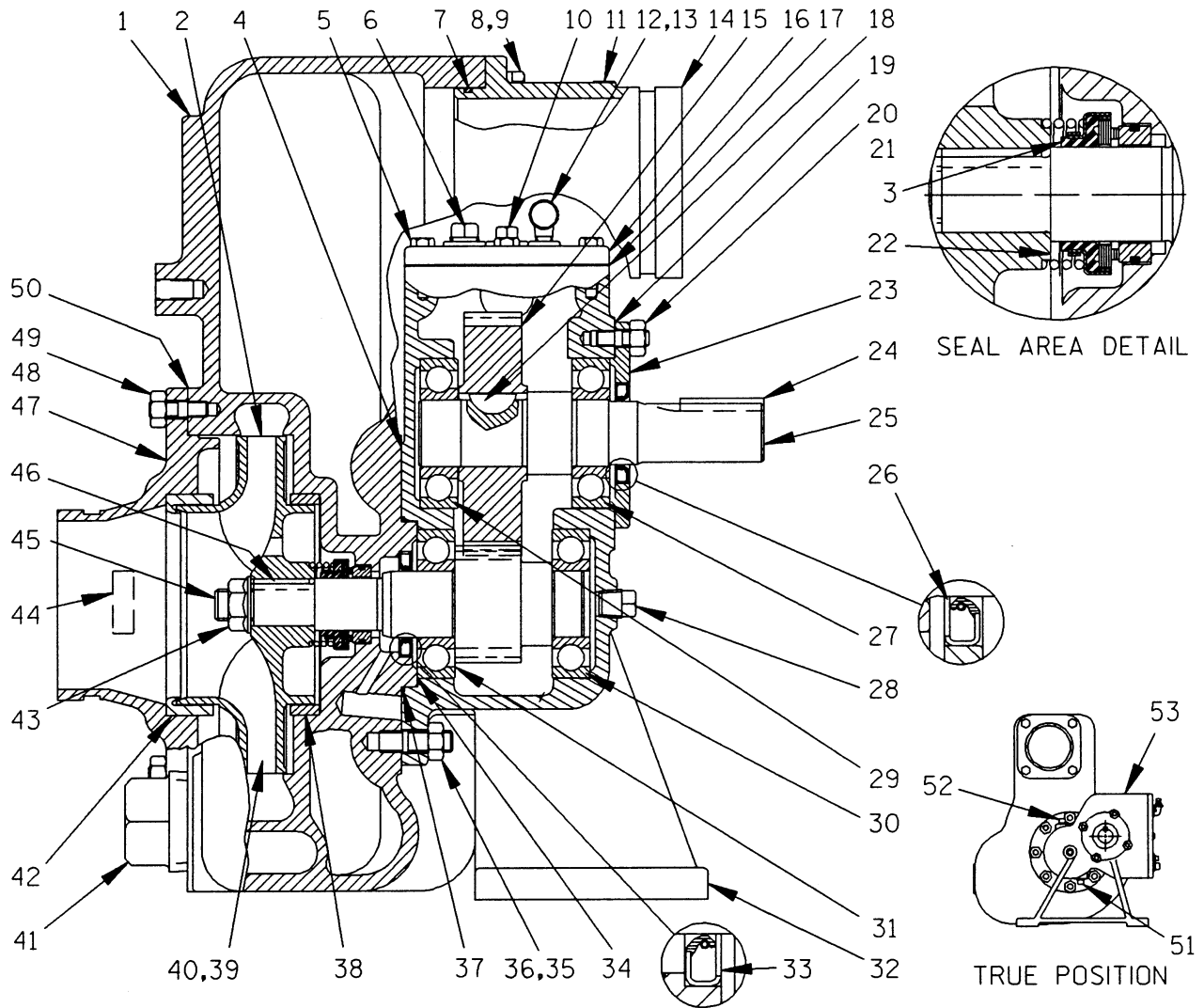

Figure 1. Pump Model 04E1-GA

**PARTS LIST**  
**Pump Model 04E1-GA**  
 (From S/N 1003835 up)

If your pump serial number is followed by an "N", your pump is **NOT** a standard production model. Contact the Gorman-Rupp Company to verify part numbers.

ITEM NO.	PART NAME	PART NUMBER	MAT'L CODE	QTY	ITEM NO.	PART NAME	PART NUMBER	MAT'L CODE	QTY
1	PUMP CASING	38222-528	13005	1	31 *	INBOARD PINION BRG	S1080	-----	1
2 *	IMPELLER	8375	1304R	1	32	GEARBOX HOUSING	10200	10010	1
3 *	SEAL ASSEMBLY	25271-192	-----	1	33 *	OIL SEAL	S2007	-----	1
4 *	GEARBOX HSG GASKET	8377G	18000	1	34 *	BEARING SHIM SET	8543	15990	1
5	HEX HD CAPSCREW	B0503	15991	8	35	STUD	C0807	15991	6
6	PIPE PLUG	P06	15079	1	36	HEX NUT	D08	15991	6
7 *	DISCH FLANGE O-RING	25155-244	-----	1	37 *	GEARBOX HSG O-RING	S2085	-----	1
8	HEX HD CAPSCREW	B0805	15991	4	38 *	WEAR RING	8464	10018	1
9	LOCKWASHER	J08	15991	4	39	NAME PLATE	38818-020	13990	1
10	PIPE PLUG	P04	15079	1	40	DRIVE SCREW	BM#04-03	15990	4
11	ROTATION DECAL	2613BM	-----	1	41	CASING DRAIN PLUG	P32	10009	1
12	STREET ELBOW	RS02	11999	1	42 *	WEAR RING	64H5	10018	1
13	AIR VENT	S1530	-----	1	43	IMP FLANGED NUT	22565-307	-----	1
14	DISCHARGE FLANGE	38641-314	13005	1	44	SUCTION STICKER	6588AG	-----	1
15	DRIVE GEAR	38541-206	16000	1	45	PINION SHAFT	38521-711	16000	1
16	COVER PLATE ASSY	10210A	24020	1	46 *	IMPELLER KEY	N0405 1/4	15990	1
17 *	COVER PLATE GASKET	10210G	18000	1	47	SUCTION HEAD	38247-206	13045	1
18 *	WOODRUFF KEY	AV1009	15990	1	48	STUD	C0605 1/2	15991	12
19 *	BEARING CAP GASKET	10213G	18000	1	49	HEX NUT	D06	15991	12
20	STUD	C0605	15991	4	50 *	SUCTION HEAD GASKET	8376G	20000	1
21	HEX NUT	D06	15991	4	51	MAGNETIC PIPE PLUG	PM06	15079	1
22 *	IMPELLER SHIM SET	2X	17090	1	52	PIPE PLUG	P06	15079	1
23	BEARING CAP	10213	10010	1	53	GEARBOX LUBE DECAL	38816-077	-----	1
24 *	SHAFT KEY	N0508	15990	1					
25	DRIVE SHAFT	10209	16040	1	NOT SHOWN:				
26 *	OIL SEAL	S506	-----	1	SHIPPING PLUG	11495C	15079	1	
27 *	OUTBOARD DRIVE BRG	S1080	-----	1	OPTIONAL:				
28	PIPE PLUG	P06	15079	1	BRONZE PARTS:				
29 *	INBOARD DRIVE BRG	S1080	-----	1	-IMPELLER	8375	14000	1	
30 *	OUTBOARD PINION BRG	S1080	-----	1	-WEAR RING	64H5	14000	1	

\* INDICATES PARTS RECOMMENDED FOR STOCK

Above Serial Numbers Do Not Apply To Pumps Made In Canada.

CANADIAN SERIAL NO. .... AND UP

## PUMP AND SEAL DISASSEMBLY AND REASSEMBLY

Review all SAFETY information in Section A.

Follow the instructions on all tags, label and decals attached to the pump.

This pump requires little service due to its rugged, minimum-maintenance design. However, if it becomes necessary to inspect or replace the wearing parts, follow these instructions which are keyed to the sectional view (see Figure 1) and the accompanying parts list.

Most service functions, such as impeller, wear ring, and seal replacement, may be performed by draining the pump and removing the suction head. However, due to the confined mounting location of the pump, it is recommended that the pump and gearbox be removed from the vehicle for service. The following instructions assume complete disassembly is required.

If the gearbox requires repair, proceed with **PUMP AND SEAL DISASSEMBLY**, followed by **GEARBOX DISASSEMBLY**.

Before attempting to service the pump, switch off the vehicle ignition and remove the key, or take other safety precautions to ensure that it will remain inoperative. Close all valves in the suction and discharge lines.



**Before attempting to open or service the pump:**

1. **Familiarize yourself with this manual.**
2. **Switch off the vehicle ignition and remove the key, or take other precautions to ensure that the pump will remain inoperative.**
3. **Allow the pump to cool if overheated.**

4. **Check the temperature before opening any covers, plates, or plugs.**
5. **Close the suction and discharge valves.**
6. **Vent the pump slowly and cautiously.**
7. **Drain the pump.**



**After the vehicle is positioned for pump maintenance, block the wheels and set the emergency brake before attempting to disconnect the drive shaft or remove the pump. Be sure the pump is properly reinstalled and secured before operation.**

### Removing Pump and Gearbox

Due to the confined mounting location, it is recommended that the pump and gearbox be removed from the vehicle for service.



The pump assembly can be seriously damaged if the cables or chains used to lift and move the unit are improperly wrapped around the pump.

Due to the confined mounting location, specialized equipment such as a transmission jack with custom brackets should be used to lift and position the pump and gearbox.

Close all valves in the suction and discharge lines. Remove the pump casing drain plug (41) and drain the pump. Clean and reinstall the drain plug using 'Loctite Primer N and PST'.





**Use lifting and moving equipment in good repair and with adequate capacity to prevent injuries to personnel or damage to equipment.**

Disconnect the P.T.O. shaft from the gearbox drive shaft. Remove all the hardware securing the pump and gearbox to the vehicle chassis. Tie and tag the any leveling shims used under the casing mounting feet to ease reassembly. Move the pump and gearbox to a clean, well-equipped shop for maintenance and repair.

#### **Suction Head and Wear Ring Removal**

The wear ring (42) can be serviced by removing the suction head (47). Remove the nuts (49) and pull the suction head and wear ring out of the pump casing. Remove the suction head gasket (50).

Inspect the wear ring (42) for excessive wear or scoring. The wear ring is secured in the suction head by a press fit. If replacement is required, use a small bit to drill two holes through the ring horizontally, 180° apart. Use a saw and chisel to complete the cuts through the ring, and remove it from the suction head. **Use caution** not to damage the suction head bore when removing the ring.



**Use caution not to damage the suction head when removing the wear ring.**

#### **Impeller And Pump Casing Wear Ring Removal**

Immobilize the drive shaft (25) and remove the impeller nut (43). **Be careful** not to damage the drive shaft.

Install three 1/4-20 UNC x 2-1/2 inch long capscrews (not supplied) in the tapped holes in the impeller. Use a suitable puller to remove the impeller from the shaft. Retain the shaft key (46). Remove the impeller adjusting shims (22). Use caution when removing

the impeller; tension on the seal spring will be released as the impeller is removed.

With the impeller removed, inspect the pump casing wear ring (38) for excessive wear or scoring. The wear ring is secured in the pump casing by a press fit. If replacement is required, use a small bit to drill two holes through the ring horizontally, 180° apart. Use a saw and chisel to complete the cuts through the ring, and remove it from the casing. **Use caution** not to damage the pump casing bore when removing the ring.



**Use caution not to damage the pump casing when removing the wear ring.**

#### **Seal Removal and Disassembly**

Remove the seal spring. Lubricate the pinion shaft (45) adjacent to the seal, and work oil up under the rubber bellows. Slide the rotating portion of the seal off the shaft.

Use a pair of stiff wires with hooked ends to hook the stationary element from the back side, and pull the element and O-ring from the seal bore in the pump casing.

#### **Pump Casing Removal**

If the oil seal (33), housing gasket (4), or O-ring (37) require replacement, or if the gearbox is to be disassembled, remove the nuts (36) and slide the pump casing off the shaft. Remove the housing gasket and O-ring.

Remove the bearing shims (34). Tie and tag the shims, or measure and record their thickness for ease of reassembly.

Place the pump casing (1) on a clean surface with the suction head opening facing up, and use a screwdriver or other suitable tool to press the oil seal (33) from the pump casing.

If the discharge flange (14) or O-ring (7) require replacement, remove the hardware (8 and 9), and pull the flange from the pump casing. Remove the O-ring from the groove in the flange.

If no further disassembly is required, proceed with **PUMP AND SEAL REASSEMBLY**. If the gearbox requires disassembly, do not reassemble the pump components at this time. Refer to **GEARBOX DISASSEMBLY** and **GEARBOX REASSEMBLY**, followed by **PUMP AND SEAL REASSEMBLY**.

## PUMP AND SEAL REASSEMBLY

If the gearbox requires disassembly, refer to **GEARBOX DISASSEMBLY** and **GEARBOX REASSEMBLY**, followed by **PUMP AND SEAL REASSEMBLY**.

### Pump Casing Installation

If the discharge flange (14) was removed, lubricate a new O-ring (7) and install it in the groove in the flange. Press the flange into the pump casing and secure it with the hardware (8 and 9).

If the wear ring (38) was removed for replacement, press the replacement ring into the pump casing (1) until it seats squarely against the shoulder bore.



The wear ring **must** seat squarely in the pump casing bore or binding and/or excessive wear will result.

Position the oil seal (33) in the casing bore with the lip positioned as shown in Figure 1. Press the oil seal into the bore until fully seated against the bore shoulder.

Lubricate the O-ring (37) and install it in the groove in the gearbox housing (32). Install the same thickness of bearing adjusting shims (34) as previously removed.

### NOTE

*Shaft endplay should be between .005 and .012 inch (0,127 and 0,305 mm). Add or remove bearing shims to achieve correct endplay.*

Install the gearbox housing gasket (4) over the casing studs (35). Carefully slide the pump casing over the shaft until fully seated against the gearbox hous-

ing. **Be careful** not to damage the lip of the oil seal on the shaft keyway. **Make sure** the bearing shims remain in position in the casing bore. Secure the casing to the gearbox with the nuts (36).

### Seal Reassembly and Installation

(Figures 1 and 2)

Clean the seal cavity and shaft with a cloth soaked in fresh cleaning solvent.



**Most cleaning solvents are toxic and flammable. Use them only in a well-ventilated area free from excessive heat, sparks, and flame. Read and follow all precautions printed on solvent containers.**

The seal is not normally reused because wear patterns on the finished faces cannot be realigned during reassembly. This could result in premature failure. If necessary to reuse an old seal in an emergency, carefully wash all metallic parts in **fresh** cleaning solvent and allow to dry thoroughly.

Handle the seal parts with extreme care to prevent damage. Be careful not to contaminate precision finished faces; even fingerprints on the faces can shorten seal life. If necessary, clean the faces with a non-oil based solvent and a clean, lint-free tissue. Wipe **lightly** in a concentric pattern to avoid scratching the faces.

Inspect the seal components for wear, scoring, grooves, and other damage that might cause leakage. Clean and polish the pinion shaft, or replace it if there are nicks or cuts on either end (see **GEARBOX DISASSEMBLY**). If any components are worn, replace the complete seal; **never mix old and new seal parts.**

If a replacement seal is being used, remove it from the container and inspect the precision finished faces to ensure that they are free of any foreign matter.

To ease installation of the seal, lubricate the stationary seat O-ring, bellows and pinion shaft with water

or a very small amount of oil, and apply a drop of light lubricating oil on the finished faces. Assemble

the seal as follows, (see Figure 2).

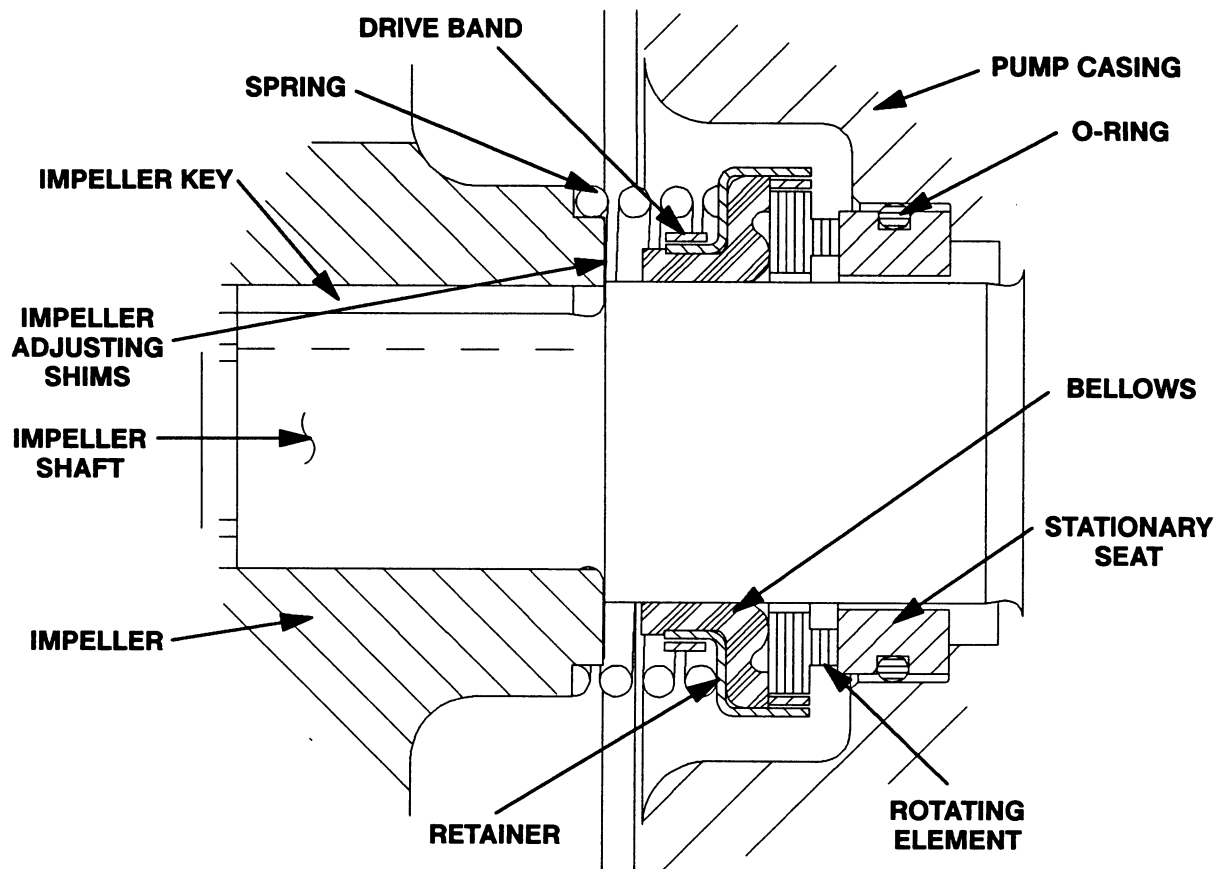
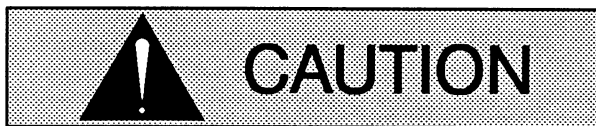

Figure 2. 25271-192 Seal Assembly



This seal is not designed for operation at temperatures above 160°F (71°C). Do not use at higher operating temperatures.

Inspect the pinion shaft (45) for distortion, nicks, scratches, or damage to the shaft keyway. Dress small nicks or burrs with a fine file or emery cloth. If excessive wear exists or the shaft is defective, refer to **GEARBOX DISASSEMBLY** and replace the shaft.

Lubricate the stationary seat O-ring with light oil and install it in the groove in the stationary seat. Use thumb pressure to press this subassembly into the pump casing until fully seated. Be careful not to damage the seal face. After installation, wipe the seal face in a concentric pattern with a clean, lint-free cloth to remove any fingerprints.

#### NOTE

*It is recommended that a tapered sleeve (see Figure 3) be installed over the shaft keyway to ease installation of the rotating portion of the seal. This tool can be made from steel tubing or black pipe.*

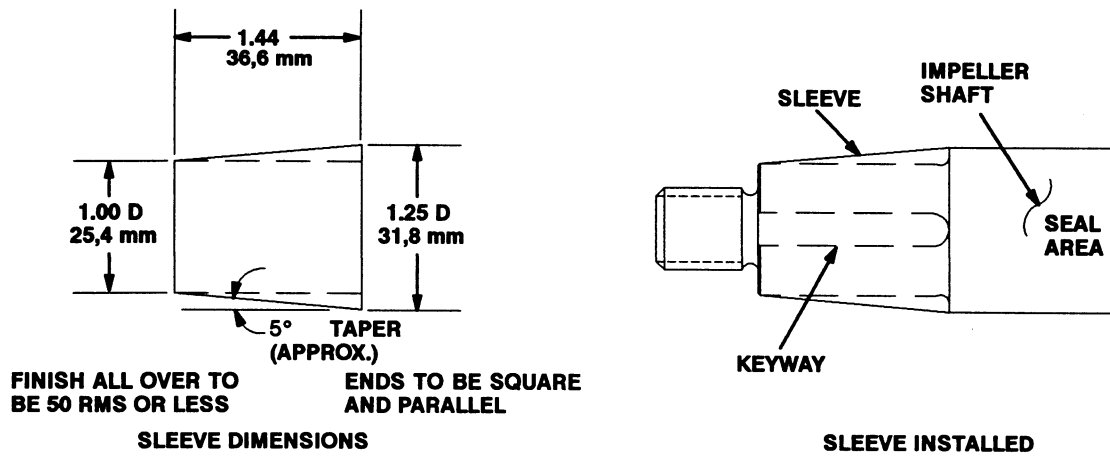

**Figure 3. Seal Installation Sleeve**

Lubricate the tapered sleeve and position it on the shaft. Position the rotating portion of the seal (consisting of the retainer, bellows and rotating element) on the sleeve, and apply even pressure against the shoulder of the seal retainer until the rotating sub-assembly slides onto the shaft and the seal faces contact. A push tube cut from a piece of plastic tubing would aid this installation. The I.D. of the tube should be approximately the same diameter as the I.D. of the seal spring.

Remove the tapered sleeve and install the seal spring. Make sure that all components of the seal are seated squarely.

**Impeller And Pump Casing Wear Ring Installation**

(Figures 1 and 4)

Inspect the impeller (2), and replace it if cracked or badly worn.

For maximum pump efficiency, the impeller must be centered within the volute scroll. To verify impeller positioning, measure the pump casing and impeller as shown in Figure 4. Use these measurements to calculate the required impeller location (dimension E). Add or remove impeller adjusting shims (22) to obtain dimension E.

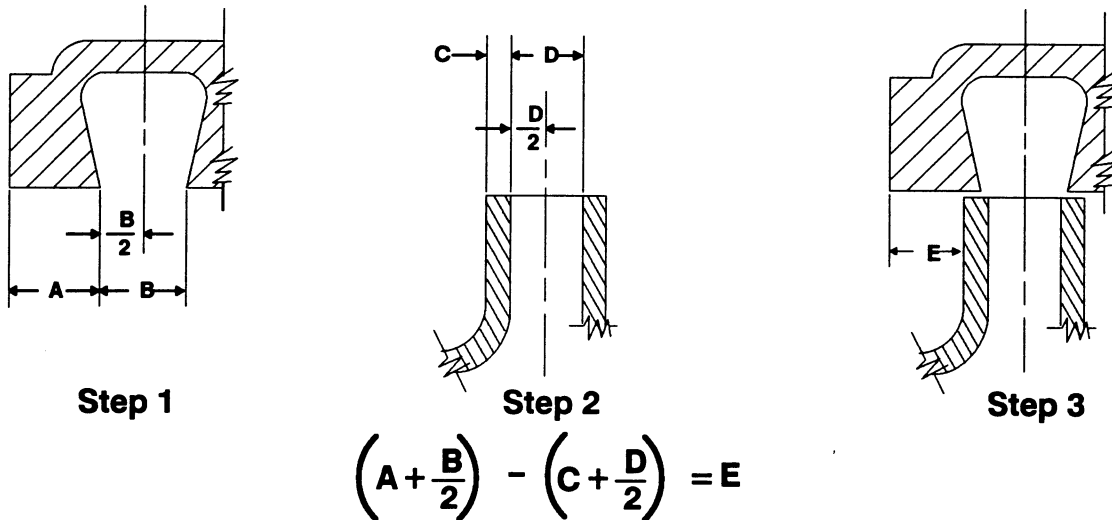

**Figure 4. Centering Impeller Within Pump Casing**

With the correct thickness of impeller adjusting shims installed, apply 'Loctite Primer Grade T', followed by 'Loctite Retaining Compound No. 242' to

the keyway, impeller key (46) and shaft threads (use no substitutes).

**NOTE**

*It is not recommended that substitute locking materials be used in this application. Use **only** the recommended 'Loctite' products.*

Align the impeller and key with the shaft keyway, and press the impeller onto the shaft until fully seated. **Be sure** the seal spring seats squarely over the shoulder on the back of the impeller.

After the impeller is installed, immobilize the drive shaft (25), and install the impeller nut (43). Torque the impeller nut to 120 ft. lbs. (1440 in. lbs. or 16.6 m. kg.).

**NOTE**

*After the impeller has been installed, check for free rotation. Correct any scraping or binding before further reassembly.*

**Suction Head and Wear Ring Installation**

If the wear ring (42) was removed for replacement, press the replacement ring into the suction head (47) until it seats squarely against the shoulder bore.



The wear ring **must** seat squarely in the suction head bore or binding and/or excessive wear will result.

Install the suction head gasket (50) over the studs (48). Slide the suction head over the studs, and secure with the nuts (49).

**Installing Pump and Gearbox**

Secure the pump and gearbox to the vehicle chassis with the previously removed hardware. Be sure to install any leveling shims used under the casing mounting feet.

Reconnect the P.T.O. shaft to the gearbox drive shaft, and check the alignment as described in **INSTALLATION**, Section B.

Install the suction and discharge lines and open all valves. Make certain that all piping connections are tight, properly supported and secure.

**Be sure** the pump and gearbox have been properly lubricated (see **LUBRICATION**).

Refer to **OPERATION**, Section C, before putting the pump back into service.

**GEARBOX DISASSEMBLY**

When the pump is properly operated and maintained, the gearbox should not require disassembly. Disassemble the gearbox **only** when there is evidence of wear or damage.



Gearbox disassembly in the field is not recommended. These operations should be performed only in a properly-equipped shop by qualified personnel.

If the gearbox requires disassembly, first disassemble the pump components as indicated in **PUMP AND SEAL DISASSEMBLY**.

Before attempting to disassemble the gearbox, remove the magnetic drain plug (51) and drain the lubricant. Clean and reinstall the drain plug.

With the pump end components removed, remove the pipe plug (28) and use a drift pin to tap the pinion shaft (45) and bearings (30 and 31) from the gearbox housing (32).

Remove the shaft key (24). Remove the nuts (21) and slide the bearing cap (23) and assembled oil seal (26) off the shaft. Remove the bearing cap gasket (19). Inspect the oil seal and, if replacement is required, press it from the bearing cap.

Disengage the capscrews (5) and remove the cover plate and gasket (16 and 17). Position two spacer bars on the drive side of the helical gear (15) to prevent it from moving as the drive shaft (25) is removed.

Install a standard 5/8-11 UNC x 1-1/4 inch long cap-screw (not supplied) in the tapped hole in the drive shaft and use a suitable puller to remove the drive shaft and assembled bearing (27) from the gearbox

housing. Retain the woodruff key (18) and helical gear as they come free of the shaft.

Remove the capscrew from the tapped hole in the end of the drive shaft.

The inboard bearing (29) will remain in the gearbox housing. Reach through the cover plate opening to remove the bearing.

After removing the shafts and bearings, clean and inspect the bearings **in place** as follows.



To prevent damage during removal from the shaft, it is recommended that bearings be cleaned and inspected **in place**. It is **strongly** recommended that the bearings be replaced **any** time the shaft and bearings are removed.

Clean the gear housing, helical gear, drive and pinion shafts, and all component parts (except the bearings) with a soft cloth soaked in cleaning solvent. Inspect the parts for wear or damage and replace as necessary.



**Most cleaning solvents are toxic and flammable. Use them only in a well-ventilated area free from excessive heat, sparks, and flame. Read and follow all precautions printed on solvent containers.**

Clean the bearings thoroughly in **fresh** cleaning solvent. Dry the bearings with filtered compressed air and coat with light oil.



Bearings must be kept free of all dirt and foreign material. Failure to do so will greatly shorten bearing life. **Do not** spin dry bear-

ings. This may scratch the balls or races and cause premature bearing failure.

Rotate the bearings by hand to check for roughness or binding and inspect the bearing balls. If rotation is rough or the bearing balls discolored, replace the bearings.

The bearing tolerances provide a tight press fit onto the shafts and a snug slip fit into the gearbox housing. Replace the bearings, shafts or gearbox housing if the proper bearing fit is not achieved.

If the bearings, pinion or drive shafts require replacement, use a suitable puller to remove the bearings.

## GEARBOX REASSEMBLY

Clean and inspect the bearings as indicated in **GEARBOX DISASSEMBLY**.



To prevent damage during removal from the shaft, it is recommended that bearings be cleaned and inspected **in place**. It is **strongly** recommended that the bearings be replaced **any** time the shaft and bearings are removed.

Inspect the helical gear (15), pinion shaft (45) and drive shaft (25) for distortion, excessive wear, broken teeth, damaged keyways, nicks or scratches, or for damage on the impeller or drive ends of the shafts. Dress small nicks or burrs with a fine file or emery cloth. Replace the shafts or gear as required.

## NOTE

*All of the bearings used in the gearbox are identical parts; however, the inboard drive shaft bearing (29) **should not** be heated and installed on the shaft prior to reassembling the gearbox.*

The outboard drive bearing (27) and pinion shaft bearings (30 and 31) may be heated to ease installation. An induction heater, hot oil bath, electric oven, or hot plate may be used to heat the bearings. Bearings should **never** be heated with a direct flame or directly on a hot plate.

## NOTE

*If a hot oil bath is used to heat the bearings, both the*

*oil and the container must be **absolutely clean**. If the oil has been previously used, it must be **thoroughly filtered**.*

Heat the bearings to a uniform temperature **no higher than 250°F (120°C)**, and slide them onto the shafts, one at a time, until they are fully seated. This should be done quickly, in one continuous motion, to prevent the bearings from cooling and sticking on the shaft.



**Use caution when handling hot bearings to prevent burns.**

After the bearings have been installed and allowed to cool, check to ensure that they have not moved out of position in shrinking. If movement has occurred, use a suitable sized sleeve and a press to reposition the bearings.

If heating the bearings is not practical, use a suitable sized sleeve and an arbor (or hydraulic) press to install the bearings onto the shafts.



When installing the bearings onto the shafts, **never** press or hit against the outer race, balls, or ball cage. Press **only** on the inner race.

Lay the gearbox housing on the bed of an arbor (or hydraulic) press with the pump side down, and support it so it is level and stable. Lubricate the inboard drive shaft bearing (29) and slide it into the gearbox housing bore until fully seated.

Install the woodruff key (18) in the shaft keyway. Position the helical gear (15) against the inboard bearing. Slide the drive shaft and assembled outboard bearing into the gearbox housing. Align the woodruff key with the gear keyway, and slide the gear onto the shaft. Press the drive shaft into the inboard bearing until fully seated. Install the cover plate and gasket (16 and 17) and secure with the capscrews (5).

Apply a light coating of oil to the lip of the oil seal (26), and press it into the bearing cap (23) with the lip positioned as shown in Figure 1. The face of the oil seal should be just flush with the outer face of the bearing cap.

Install the bearing cap gasket (19), and slide the bearing cap over the shaft, being careful not to damage or roll the oil seal lip. Secure the bearing cap with the nuts (21).

Position the bearing housing on a flat surface with the pump side up, and support it so it is level and stable.

Slide the pinion shaft into the gearbox housing until the gear teeth mesh with those of the helical gear, and the outboard bearing (30) seats squarely against the bearing bore.

Reinstall the pipe plug (28) in the gearbox housing.

Refer to **PUMP AND SEAL REASSEMBLY** and install the remaining pump components.

### NOTE

*Pinion shaft endplay should be between .005 to .012 (0,127 to 0,305 mm). Add or remove bearing shims (34) to achieve the correct endplay.*

After the pump components are installed, lubricate the gearbox as indicated in **LUBRICATION**.

## LUBRICATION

### Seal Assembly

The seal assembly is lubricated by the medium bearing pumped and no additional lubrication is required.

### Gearbox

The gearbox was fully lubricated when shipped from the factory. Check the oil level regularly at the oil fill pipe plug (52). When lubrication is required, remove the air vent (13) and add SAE No. 90 non-detergent gear oil. Fill the gearbox until the oil level reaches the bottom of the fill plug hole. Clean and reinstall the fill plug. **Do not** over lubricate. Over-lubrication

can cause the bearings to over-heat, resulting in premature bearing failure.

### NOTE

*If the gearbox is rotated out of the standard position, the oil fill and drain plugs must be relocated. The magnetic drain plug (51) must be relocated to the lowest port, and the oil vent and elbow (12 and 13) must be relocated to the highest port. Consult the factory for correct positioning of the fill plug to provide for proper lubrication of the gearbox.*

Under normal conditions, drain the gearbox once each year. Add 2 ounces (59 ml) of Dow Corning 'Molykote® M Gear Guard', then fill with approxi-

mately 23 ounces (680 ml) of SAE No. 90 non-detergent gear oil. Change the oil more frequently if the pump is operated continuously or installed in an environment with rapid temperature change.



Monitor the condition of the bearing lubricant regularly for evidence of rust or moisture condensation. This is especially important in areas where variable hot and cold temperatures are common.

For cold weather operation, consult the factory or a lubricant supplier for the recommended grade of oil.





**For U.S. and International Warranty Information,  
Please Visit [www.grpumps.com/warranty](http://www.grpumps.com/warranty)  
or call:  
U.S.: 419-755-1280  
International: +1-419-755-1352**

**For Canadian Warranty Information,  
Please Visit [www.grcanada.com/warranty](http://www.grcanada.com/warranty)  
or call:  
519-631-2870**