

**INSTALLATION, OPERATION,  
AND MAINTENANCE MANUAL**  
WITH PARTS LIST



|                 |
|-----------------|
| <b>MODEL</b>    |
| <b>06B3-F6L</b> |

**THE GORMAN-RUPP COMPANY • MANSFIELD, OHIO**

GORMAN-RUPP OF CANADA LIMITED • ST. THOMAS, ONTARIO, CANADA Printed in U.S.A.

©Copyright by the Gorman-Rupp Company



**The engine exhaust from this product contains chemicals known to the State of California to cause cancer, birth defects or other reproductive harm.**

# TABLE OF CONTENTS

|  |                   |
|--|-------------------|
| <b>INTRODUCTION</b> .....                            | <b>PAGE I – 1</b> |
| <b>SAFETY - SECTION A</b> .....                      | <b>PAGE A – 1</b> |
| <b>INSTALLATION – SECTION B</b> .....                | <b>PAGE B – 1</b> |
| Pump Dimensions .....                                | PAGE B – 1        |
| PREINSTALLATION INSPECTION .....                     | PAGE B – 1        |
| Battery Specifications And Installation .....        | PAGE B – 2        |
| POSITIONING PUMP .....                               | PAGE B – 2        |
| Lifting .....  | PAGE B – 2        |
| Mounting .....                                       | PAGE B – 2        |
| SUCTION AND DISCHARGE PIPING .....                   | PAGE B – 3        |
| Materials .....                                      | PAGE B – 3        |
| Line Configuration .....                             | PAGE B – 3        |
| Connections to Pump .....                            | PAGE B – 3        |
| Gauges .....   | PAGE B – 3        |
| SUCTION LINES .....                                  | PAGE B – 3        |
| Fittings .....                                       | PAGE B – 3        |
| Strainers .....                                      | PAGE B – 3        |
| Sealing .....  | PAGE B – 3        |
| Suction Lines In Sumps .....                         | PAGE B – 4        |
| Suction Line Positioning .....                       | PAGE B – 4        |
| DISCHARGE LINES .....                                | PAGE B – 5        |
| Siphoning .....                                      | PAGE B – 5        |
| Valves .....   | PAGE B – 5        |
| Bypass Lines .....                                   | PAGE B – 5        |
| ALIGNMENT .....                                      | PAGE B – 6        |
| <b>OPERATION – SECTION C</b> .....                   | <b>PAGE C – 1</b> |
| PRIMING .....  | PAGE C – 1        |
| STARTING .....                                       | PAGE C – 1        |
| OPERATION .....                                      | PAGE C – 1        |
| Lines With a Bypass .....                            | PAGE C – 1        |
| Lines Without a Bypass .....                         | PAGE C – 2        |
| Leakage .....  | PAGE C – 2        |
| Liquid Temperature And Overheating .....             | PAGE C – 2        |
| Strainer Check .....                                 | PAGE C – 2        |
| Pump Vacuum Check .....                              | PAGE C – 2        |
| STOPPING .....                                       | PAGE C – 2        |
| Cold Weather Preservation .....                      | PAGE C – 3        |
| BEARING TEMPERATURE CHECK .....                      | PAGE C – 3        |
| <b>TROUBLESHOOTING – SECTION D</b> .....             | <b>PAGE D – 1</b> |
| <b>PUMP MAINTENANCE AND REPAIR - SECTION E</b> ..... | <b>PAGE E – 1</b> |
| STANDARD PERFORMANCE CURVE .....                     | PAGE E – 1        |

**TABLE OF CONTENTS**  
**(continued)**

|   |             |
|---|-------------|
| PARTS LISTS:  |             |
| Pump Model .....                                    | PAGE E – 3  |
| Pump End Assembly .....                             | PAGE E – 5  |
| PUMP AND SEAL DISASSEMBLY AND REASSEMBLY .....      | PAGE E – 6  |
| Pump Disassembly .....                              | PAGE E – 6  |
| Impeller Removal .....                              | PAGE E – 7  |
| Seal Removal and Disassembly .....                  | PAGE E – 7  |
| Separating Intermediate From Engine .....           | PAGE E – 7  |
| Shaft and Bearing Removal and Disassembly .....     | PAGE E – 7  |
| Shaft and Bearing Reassembly and Installation ..... | PAGE E – 8  |
| Securing Intermediate To Engine .....               | PAGE E – 9  |
| Seal Reassembly and Installation .....              | PAGE E – 9  |
| Impeller Installation .....                         | PAGE E – 11 |
| Pump Reassembly .....                               | PAGE E – 11 |
| Final Pump Assembly .....                           | PAGE E – 11 |
| LUBRICATION .....                                   | PAGE E – 12 |
| Seal Assembly .....                                 | PAGE E – 12 |
| Bearings .....                                      | PAGE E – 12 |
| Engine .....  | PAGE E – 12 |

## INTRODUCTION

This Installation, Operation, and Maintenance manual is designed to help you achieve the best performance and longest life from your Gorman-Rupp pump.

This pump is a 0 Series, closed impeller, self-priming centrifugal model. The pump is designed with straight-in suction, without a suction check valve. It is close-coupled to a Deutz F6L diesel engine and designed for handling liquids that do not contain large solids. The basic material of construction for wetted parts is gray iron with bronze impeller and gray iron wear rings.

If there are any questions regarding the pump or its application which are not covered in this manual or in other literature accompanying this unit, please contact your Gorman-Rupp distributor, or write:

**The Gorman-Rupp Company**  
**P.O. Box 1217**  
**Mansfield, Ohio 44901-1217**  
 or  
**Gorman-Rupp of Canada Limited**  
**70 Burwell Road**  
**St. Thomas, Ontario N5P 3R7**

For information or technical assistance on the engine, contact the engine manufacturer's local dealer or representative.

Because pump installations are seldom identical, this manual cannot possibly provide detailed instructions and precautions for every aspect of each specific application. Therefore, it is the responsibility of the owner/installer of the pump to ensure that applications not addressed in this manual are performed **only** after establishing that neither operator safety nor pump integrity are compromised by the installation. Pumps and related equipment **must** be installed and operated ac-

ording to all national, local and industry standards.

The following are used to alert maintenance personnel to procedures which require special attention, to those which could damage equipment, and to those which could be dangerous to personnel:



**Immediate hazards which WILL result in severe personal injury or death. These instructions describe the procedure required and the injury which will result from failure to follow the procedure.**



**Hazards or unsafe practices which COULD result in severe personal injury or death. These instructions describe the procedure required and the injury which could result from failure to follow the procedure.**



Hazards or unsafe practices which COULD result in minor personal injury or product or property damage. These instructions describe the requirements and the possible damage which could result from failure to follow the procedure.

### NOTE

*Instructions to aid in installation, operation, and maintenance, or which clarify a procedure.*

## SAFETY - SECTION A

These warnings apply to 0 series engine driven pumps. Refer to the manual accompanying the engine before attempting to begin operation.

Because pump installations are seldom identical, this manual cannot possibly provide detailed instructions and precautions for each specific application. Therefore, it is the owner/installer's responsibility to ensure that applications not addressed in this manual are performed only after establishing that neither operator safety nor pump integrity are compromised by the installation.



Before attempting to open or service the pump:

1. Familiarize yourself with this manual.
2. Switch off the engine ignition and disconnect the positive battery cable to ensure that the pump will remain inoperative.
3. Allow the pump to completely cool if overheated.
4. Check the temperature before opening any covers, plates, or plugs.
5. Close the suction and discharge valves.
6. Vent the pump slowly and cautiously.
7. Drain the pump.



This pump is designed to handle clean liquids containing specified entrained solids. Do not attempt to pump volatile,

corrosive, or flammable liquids which may damage the pump or endanger personnel as a result of pump failure.



Use lifting and moving equipment in good repair and with adequate capacity to prevent injuries to personnel or damage to equipment. Suction and discharge hoses and piping must be removed from the pump before lifting.



After the pump has been installed, make certain that the pump and all piping or hose connections are tight, properly supported and secure before operation.



Do not operate the pump against a closed discharge valve for long periods of time. If operated against a closed discharge valve, pump components will deteriorate, and the liquid could come to a boil, build pressure, and cause the pump casing to rupture or explode.



Overheated pumps can cause severe burns and injuries. If overheating of the pump occurs:

1. Stop the pump immediately.
2. Ventilate the area.
3. Allow the pump to completely cool.
4. Check the temperature before opening any covers, plates, gauges, or plugs.

5. Vent the pump slowly and cautiously.
6. Refer to instructions in this manual before restarting the pump.



Do not remove plates, covers, gauges, pipe plugs, or fittings from an overheated pump. Vapor pressure within the pump can cause parts being disengaged to be ejected with great force. Allow the pump to cool before servicing.



Do not operate an internal combustion engine in an explosive atmosphere. When operating internal combustion engines in an enclosed area, make certain that exhaust fumes are piped to the outside. These fumes contain carbon

monoxide, a deadly gas that is colorless, tasteless, and odorless.



Fuel used by internal combustion engines presents an extreme explosion and fire hazard. Make certain that all fuel lines are securely connected and free of leaks. Never refuel a hot or running engine. Avoid overfilling the fuel tank. Always use the correct type of fuel.



Never tamper with the governor to gain more power. The governor establishes safe operating limits that should not be exceeded. The maximum continuous operating speed for this pump is 2000 RPM.

## INSTALLATION – SECTION B

### Review all SAFETY information in Section A.

Since pump installations are seldom identical, this section offers only general recommendations and practices required to inspect, position, and arrange the pump and piping.

Most of the information pertains to a standard **static lift** application where the pump is positioned above the free level of liquid to be pumped.

If installed in a **flooded suction application** where the liquid is supplied to the pump under pressure, some of the information such as mounting, line

configuration, and priming must be tailored to the specific application. Since the pressure supplied to the pump is critical to performance and safety, **be sure** to limit the incoming pressure to 50% of the maximum permissible operating pressure as shown on the pump performance curve.

For further assistance, contact your Gorman-Rupp distributor or the Gorman-Rupp Company.

### Pump Dimensions

See Figure 1 for the approximate physical dimensions of this pump.

### OUTLINE DRAWING

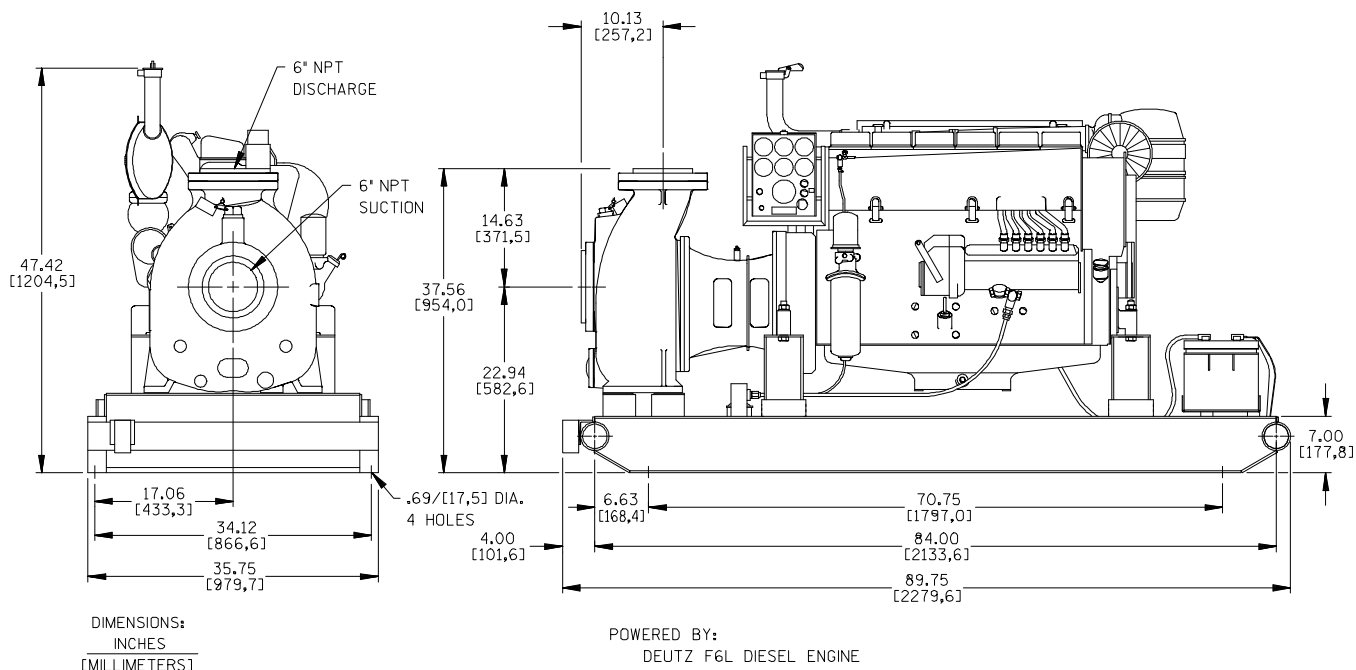

**Figure 1. Pump Model 06B3-F6L**

### PREINSTALLATION INSPECTION

The pump assembly was inspected and tested before shipment from the factory. Before installation, inspect the pump for damage which may have occurred during shipment. Check as follows:

- a. Inspect the pump and engine for cracks, dents, damaged threads, and other obvious damage.
- b. Check for and tighten loose attaching hardware. Since gaskets tend to shrink after drying, check for loose hardware at mating surfaces.



- c. Carefully read all tags, decals, and markings on the pump assembly, and perform all duties indicated.
- d. Check levels and lubricate as necessary. Refer to **LUBRICATION** in the **MAINTENANCE AND REPAIR** section of this manual and perform duties as instructed.
- e. If the pump and engine have been stored for more than 12 months, some of the components or lubricants may have exceeded their maximum shelf life. These **must be inspected or replaced** to ensure maximum pump service.

If the maximum shelf life has been exceeded, or if anything appears to be abnormal, contact your Gorman-Rupp distributor or the factory to determine the repair or updating policy. **Do not** put the pump into service until appropriate action has been taken.

**Battery Specifications And Installation**

Unless otherwise specified on the pump order, the engine battery was **not** included with the unit. Refer to the following specifications when selecting a battery.

**Table 1. Battery Specifications**

| Voltage  | Cold Crank Amps @ 0°F | Reserve Capacity @80°F (Minutes) | Amp/ Hr. Rating | Approx. Overall Dims. (Inches)    |
|----------|-----------------------|----------------------------------|-----------------|-----------------------------------|
| 12 Volts | 960-975               | 365                              | 175             | 20.5L<br>x<br>8.75W<br>x<br>9.75H |

Refer to the information accompanying the battery and/or electrolyte solution for activation and charging instructions.

Before installing the battery, clean the positive and negative cable connectors, and the battery terminals. Secure the battery by tightening the holddown brackets. The terminals and clamps may be coated with petroleum jelly to retard corrosion. Connect and tighten the positive cable first, then the negative cable.

**POSITIONING PUMP**



**Use lifting and moving equipment in good repair and with adequate capacity to prevent injuries to personnel or damage to equipment. Suction and discharge hoses and piping must be removed from the pump before lifting.**

**Lifting**

Use lifting equipment with a capacity of at least **11,350 pounds (5143,7 kg)**. This pump weighs approximately **2,268 pounds (1028,7 kg)**, not including the weight of accessories and optional wheel kit. Customer installed equipment such as suction and discharge piping **must** be removed before attempting to lift.

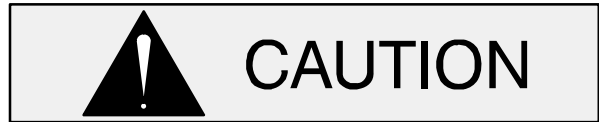

The pump assembly can be seriously damaged if the cables or chains used to lift and move the unit are improperly wrapped around the pump.

**Mounting**

Locate the pump in an accessible place as close as practical to the liquid being pumped. Level mounting is essential for proper operation.

The pump may have to be supported or shimmed to provide for level operation or to eliminate vibration.

If the pump has been mounted on a moveable base, make certain the base is stationary by setting the brake and blocking the wheels before attempting to operate the pump.

To ensure sufficient lubrication and fuel supply to the engine, **do not** position the pump and engine more than 15° off horizontal for continuous operation. The pump and engine may be positioned up to 30° off horizontal for **intermittent operation only**; however, the engine manufacturer should be

consulted for continuous operation at angles greater than 15°.

## SUCTION AND DISCHARGE PIPING

Pump performance is adversely effected by increased suction lift, discharge elevation, and friction losses. See the performance curve and notes on Page E-1 to be sure your overall application allows pump to operate within the safe operation range.

### Materials

Either pipe or hose may be used for suction and discharge lines; however, the materials must be compatible with the liquid being pumped. If hose is used in suction lines, it must be the rigid-wall, reinforced type to prevent collapse under suction. Using piping couplings in suction lines is not recommended.

### Line Configuration

Keep suction and discharge lines as straight as possible to minimize friction losses. Make minimum use of elbows and fittings, which substantially increase friction loss. If elbows are necessary, use the long-radius type to minimize friction loss.

### Connections to Pump

Before tightening a connecting flange, align it exactly with the pump port. Never pull a pipe line into place by tightening the flange bolts and/or couplings.

Lines near the pump must be independently supported to avoid strain on the pump which could cause excessive vibration, decreased bearing life, and increased shaft and seal wear. If hose-type lines are used, they should have adequate support to secure them when filled with liquid and under pressure.

### Gauges

Most pumps are drilled and tapped for installing discharge pressure and vacuum suction gauges. If these gauges are desired for pumps that are not tapped, drill and tap the suction and discharge

lines not less than 18 inches (457,2 mm) from the suction and discharge ports and install the lines. Installation closer to the pump may result in erratic readings.

## SUCTION LINES

To avoid air pockets which could affect pump priming, the suction line must be as short and direct as possible. When operation involves a suction lift, the line must always slope upward to the pump from the source of the liquid being pumped; if the line slopes down to the pump at any point along the suction run, air pockets will be created.

### Fittings

Suction lines should be the same size as the pump inlet. If reducers are used in suction lines, they should be the eccentric type, and should be installed with the flat part of the reducers uppermost to avoid creating air pockets. Valves are not normally used in suction lines, but if a valve is used, install it with the stem horizontal to avoid air pockets.

### Strainers

If a strainer is furnished with the pump, be certain to use it; any spherical solids which pass through a strainer furnished with the pump will also pass through the pump itself.

If a strainer is not furnished with the pump, but is installed by the pump user, make certain that the total area of the openings in the strainer is at least three or four times the cross section of the suction line, and that the openings will not permit passage of solids larger than the solids handling capability of the pump.

This pump is designed to handle up to 5/8-inch (15,88 mm) diameter spherical solids.

### Sealing

Since even a slight leak will affect priming, head, and capacity, especially when operating with a high suction lift, all connections in the suction line should be sealed with pipe dope to ensure an airtight seal. Follow the sealant manufacturer's recommendations when selecting and applying the

pipe dope. The pipe dope should be compatible with the liquid being pumped.

**Suction Lines In Sumps**

If a single suction line is installed in a sump, it should be positioned away from the wall of the sump at a distance equal to 1 1/2 times the diameter of the suction line.

If there is a liquid flow from an open pipe into the sump, the flow should be kept away from the suction inlet because the inflow will carry air down into the sump, and air entering the suction line will reduce pump efficiency.

If it is necessary to position inflow close to the suction inlet, install a baffle between the inflow and the suction inlet at a distance 1-1/2 times the diameter of the suction pipe. The baffle will allow entrained air to escape from the liquid before it is drawn into the suction inlet.

If two suction lines are installed in a single sump, the flow paths may interact, reducing the efficiency of one or both pumps. To avoid this, position the suction inlets so that they are separated by a distance equal to at least 3 times the diameter of the suction pipe.

**Suction Line Positioning**

The depth of submergence of the suction line is critical to efficient pump operation. Figure 2 shows recommended minimum submergence vs. velocity.

**NOTE**

*The pipe submergence required may be reduced by installing a standard pipe increaser fitting at the end of the suction line. The larger opening size will reduce the inlet velocity. Calculate the required submergence using the following formula based on the increased opening size (area or diameter).*

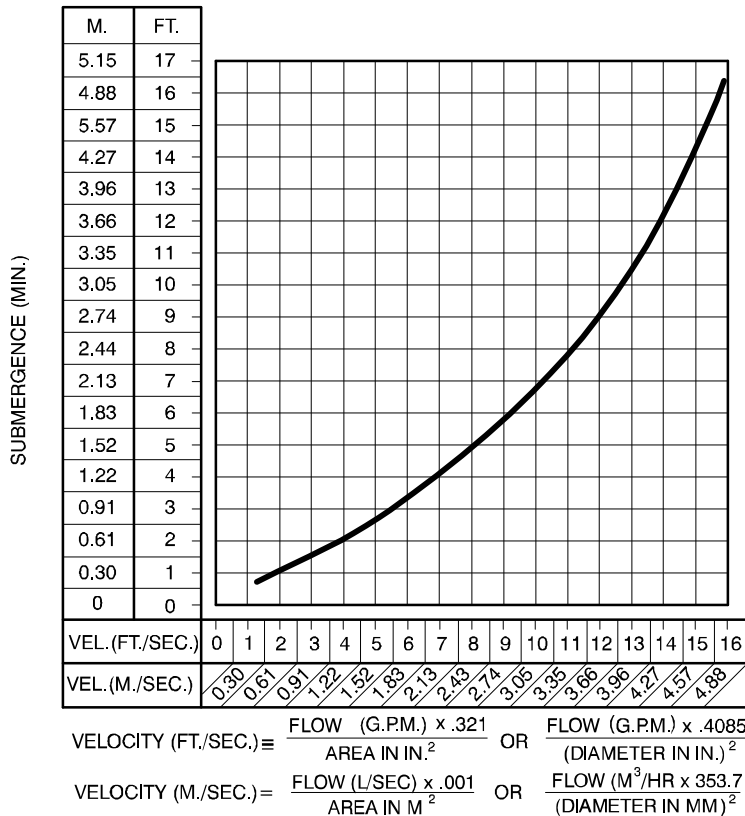

**Figure 2. Recommended Minimum Suction Line Submergence vs. Velocity**

## DISCHARGE LINES

### Siphoning

Do not terminate the discharge line at a level lower than that of the liquid being pumped unless a siphon breaker is used in the line. Otherwise, a siphoning action causing damage to the pump could result.

### Valves

If a throttling valve is desired in the discharge line, use a valve as large as the largest pipe to minimize friction losses. Never install a throttling valve in a suction line.

With high discharge heads, it is recommended that a throttling valve and a system check valve be installed in the discharge line to protect the pump from excessive shock pressure and reverse rotation when it is stopped.

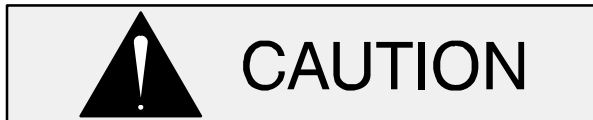

If the application involves a high discharge head, gradually close the discharge throttling valve before stopping the pump.

### Bypass Lines

Self-priming pumps are not air compressors. During the priming cycle, air from the suction line must be vented to atmosphere on the discharge side. If the discharge line is open, this air will be vented through the discharge. However, if a check valve has been installed in the discharge line, the discharge side of the pump must be opened to atmospheric pressure through a bypass line installed between the pump discharge and the check valve. A self-priming centrifugal pump **will not prime** if there is sufficient static liquid head to hold the discharge check valve closed.

#### NOTE

*The bypass line should be sized so that it does not affect pump discharge capacity; however, the bypass line should be at least 1 inch (25,4 mm) in di-*

*ameter to minimize the chance of plugging.*

In **low discharge head applications** (less than 30 feet), it is recommended that the bypass line be run back to the wet well, and located 6 inches below the water level or cut-off point of the low level pump. In some installations, this bypass outline may be terminated with a six-to-eight foot length of 1-1/4 inch I.D. (31,75 mm) **smooth-bore** hose; air and liquid vented during the priming process will then agitate the hose and break up any solids, grease, or other substances likely to cause clogging.



A bypass line that is returned to a wet well must be secured against being drawn into the pump suction inlet.

It is also recommended that pipe unions be installed at each 90° elbow in a bypass line to ease disassembly and maintenance.

In **high discharge head applications** (more than 30 feet), an excessive amount of liquid may be bypassed and forced back to the wet well under the full working pressure of the pump; this will reduce overall pumping efficiency. **Therefore, it is recommended that a Gorman-Rupp Automatic Air Release Valve be installed in the bypass line.**

Gorman-Rupp Automatic Air Release Valves are reliable, and require minimum maintenance. See **Automatic Air Release Valves** in this section for installation and theory of operation of the Automatic Air Release Valve. Consult your Gorman-Rupp distributor, or contact the Gorman-Rupp Company for selection of an Automatic Air Release Valve to fit your application.



**A manual shut-off valve should not be installed in any bypass line. A manual shut-off valve may inadvertently be left closed during operation. A pump which has lost prime may continue to operate without reaching prime, causing dan-**

gerous overheating and possible explosive rupture of the pump casing. Personnel could be severely injured.

Allow an over-heated pump to cool before servicing. DO NOT Remove plates, covers, gauges, or fittings from an over-heated pump. Liquid within the pump can reach boiling temperatures, and vapor pressure within the pump can cause parts being disengaged to be ejected with great force. After the pump cools,

drain the liquid from the pump by removing the casing drain plug. Use caution when removing the plug to prevent injury to personnel from hot liquid.

## ALIGNMENT

The alignment of the pump and the engine is critical for trouble-free mechanical operation. See Section E, **Securing Intermediate To Engine** for detailed information.

## OPERATION – SECTION C

Review all **SAFETY** Information in Section A.

Follow the instructions on all tags, labels and decals attached to the pump.



This pump is designed to handle clean liquids containing specified entrained solids. Do not attempt to pump volatile, corrosive, or flammable liquids which may damage the pump or endanger personnel as a result of pump failure.



Never tamper with the governor to gain more power. The governor establishes safe operating limits that should not be exceeded. The maximum continuous operating speed for this pump is 2000 rpm.

### PRIMING

Install the pump and piping as described in **INSTALLATION**. Make sure that the piping connections are tight, and that the pump is securely mounted. Check that the pump is properly lubricated (see **LUBRICATION** in **MAINTENANCE AND REPAIR**).

This pump is self-priming, but the pump should never be operated unless there is liquid in the pump casing.



Never operate this pump unless there is liquid in the pump casing. The pump will not prime when dry. extended operation of a dry pump will destroy the seal assembly.

Add liquid to the pump casing when:

1. The pump is being put into service for the first time.
2. The pump has not been used for a considerable length of time.
3. The liquid in the pump casing has evaporated.

Once the pump casing has been filled, the pump will prime and reprime as necessary.



After filling the pump casing, reinstall and tighten the fill plug. Do not attempt to operate the pump unless all connecting piping is securely installed. Otherwise, liquid in the pump forced out under pressure could cause injury to personnel.

To fill the pump, remove the pump casing fill cover or fill plug in the top of the casing, and add clean liquid until the casing is filled. Replace the fill cover or fill plug before operating the pump.

### STARTING

Consult the operations manual furnished with the engine.

### OPERATION

#### Lines With a Bypass

If a Gorman-Rupp Automatic Air Release Valve has been installed, the valve will automatically open to allow the pump to prime, and automatically close after priming is complete (see **INSTALLATION** for Air Release Valve operation).

If the bypass line is open, air from the suction line will be discharged through the bypass line back to the wet well during the priming cycle. Liquid will then continue to circulate through the bypass line while the pump is in operation.

## Lines Without a Bypass

Open all valves in the discharge line and start the power source. Priming is indicated by a positive reading on the discharge pressure gauge or by a quieter operation. The pump may not prime immediately because the suction line must first fill with liquid. If the pump fails to prime within five minutes, stop it and check the suction line for leaks.

After the pump has been primed, partially close the discharge line throttling valve in order to fill the line slowly and guard against excessive shock pressure which could damage pipe ends, gaskets, sprinkler heads, and any other fixtures connected to the line. When the discharge line is completely filled, adjust the throttling valve to the required flow rate.

## Leakage

No leakage should be visible at pump mating surfaces, or at pump connections or fittings. Keep all line connections and fittings tight to maintain maximum pump efficiency.

## Liquid Temperature And Overheating

The **maximum** liquid temperature for this pump is 160° F (71° C). Do not apply it at a higher operating temperature.

Overheating can occur if operated with the valves in the suction or discharge lines closed. Operating against closed valves could bring the liquid to a boil, build pressure, and cause the pump to rupture or explode. If overheating occurs, stop the pump and allow it to cool before servicing it. Refill the pump casing with cool liquid.



**Do not remove plates, covers, gauges, pipe plugs, or fittings from an overheated pump. Vapor pressure within the pump can cause parts being disengaged to be ejected with great force. allow the pump to cool before servicing.**

## Strainer Check

If a suction strainer has been shipped with the pump or installed by the user, check the strainer regularly, and clean it as necessary. The strainer should also be checked if pump flow rate begins to drop. If a vacuum suction gauge has been installed, monitor and record the readings regularly to detect strainer blockage.

**Never** introduce air or steam pressure into the pump casing or piping to remove a blockage. This could result in personal injury or damage to the equipment. If backflushing is absolutely necessary, **liquid pressure** must be limited to 50% of the maximum permissible operating pressure shown on the pump performance curve.

## Pump Vacuum Check

Since this pump does not have a suction check valve, the discharge line must be fitted with a check valve if a pump vacuum reading is to be taken.

With the pump inoperative, install a vacuum gauge in the system, using pipe dope on the threads. Block the suction line and start the pump. At operating speed the pump should pull a vacuum of 20 inches (508 mm) or more of mercury. If it does not, check for air leaks in the seal, gasket, or discharge valve.

Open the suction line, and read the vacuum gauge with the pump primed and at operation speed. Shut off the pump. The vacuum gauge reading will immediately drop proportionate to static suction lift, and should then stabilize. If the vacuum reading falls off rapidly after stabilization, an air leak exists. Before checking for the source of the leak, check the point of installation of the vacuum gauge.

## STOPPING

Never halt the flow of liquid suddenly. If the liquid being pumped is stopped abruptly, damaging shock waves can be transmitted to the pump and piping system. Close all connecting valves slowly.

On engine driven pumps, reduce the throttle speed slowly and allow the engine to idle briefly before stopping.

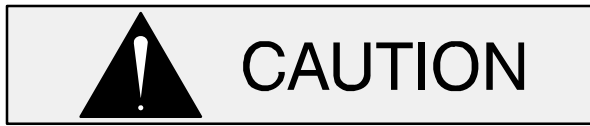

If the application involves a high discharge head, gradually close the discharge throttling valve before stopping the pump.

After stopping the pump, switch off the engine ignition and disconnect the positive battery cable to ensure that the pump will remain inoperative.

### **Cold Weather Preservation**

In below freezing conditions, drain the pump to prevent damage from freezing. Also, clean out any solids by flushing with a hose. Operate the pump for approximately one minute; this will remove any remaining liquid that could freeze the pump rotating parts. If the pump will be idle for more than a few hours, or if it has been pumping liquids containing a large amount of solids, drain the pump, and flush it thoroughly with clean water. To prevent large solids from clogging the drain port and preventing the pump from completely draining, insert a rod or stiff wire in the drain port, and agitate the

liquid during the draining process. Clean out any remaining solids by flushing with a hose.

### **BEARING TEMPERATURE CHECK**

Bearings normally run at higher than ambient temperatures because of heat generated by friction. Temperatures up to 160°F (71°C) are considered normal for bearings, and they can operate safely to at least 180°F (82°C).

Checking bearing temperatures by hand is inaccurate. Bearing temperatures can be measured accurately by placing a contact-type thermometer against the housing. Record this temperature for future reference.

A sudden increase in bearing temperatures is a warning that the bearings are at the point of failing to operate properly. Make certain that the bearing lubricant is of the proper viscosity and at the correct level (see **LUBRICATION** in Section E). Bearing overheating can also be caused by shaft misalignment and/or excessive vibration.

When pumps are first started, the bearings may seem to run at temperatures above normal. Continued operation should bring the temperatures down to normal levels.



## TROUBLESHOOTING – SECTION D

Review all SAFETY information in Section A.



**Before attempting to open or service the pump:**

1. Familiarize yourself with this manual.
2. Switch off engine ignition and disconnect the positive battery cable to ensure that the pump will remain inoperative.
3. Allow the pump to completely cool if overheated.
4. Check the temperature before opening any covers, plates, or plugs.
5. Close the suction and discharge valves.
6. Vent the pump slowly and cautiously.
7. Drain the pump.

**Table 1. Trouble Shooting Chart**

| <b>TROUBLE</b>  | <b>POSSIBLE CAUSE</b>                    | <b>PROBABLE REMEDY</b>   |
|---|--|--|
| PUMP FAILS TO PRIME                                   | Not enough liquid in casing.             | Add liquid to casing. See <b>PRIMING</b> .   |
|   | Air leak in suction line.                | Correct leak.  |
|   | Lining of suction hose collapsed.        | Replace suction hose.  |
|   | Leaking or worn seal or pump gasket.     | Check pump vacuum. Replace leaking or worn seal or gasket.                             |
|   | Suction lift or discharge head too high. | Check piping installation and install bypass line if needed. See <b>INSTALLATION</b> . |
|   | Strainer clogged.                        | Check strainer and clean if necessary.   |
| PUMP STOPS OR FAILS TO DELIVER RATED FLOW OR PRESSURE | Air leak in suction line.                | Correct leak.  |
|   | Lining of suction hose collapsed.        | Replace suction hose.  |
|   | Leaking or worn seal or pump gasket.     | Check pump vacuum. Replace leaking or worn seal or gasket.                             |

**Table 1. Trouble Shooting Chart (cont.)**

| <b>TROUBLE</b>  | <b>POSSIBLE CAUSE</b>   | <b>PROBABLE REMEDY</b>   |
|---|---|--|
| PUMP STOPS OR FAILS TO DELIVER RATED FLOW OR PRESSURE (cont.) | Strainer clogged.   | Check strainer and clean if necessary.   |
|   | Suction intake not submerged at proper level or sump too small. | Check installation and correct submergence as needed.  |
|   | Impeller or other wearing parts worn or damaged.                | Replace worn or damaged parts. Check that impeller is properly centered and rotates freely.  |
|   | Impeller clogged.   | Free impeller of debris.   |
|   | Discharge head too high.  | Install bypass line.   |
|   | Suction lift too high.  | Measure lift w/vacuum gauge. Reduce lift and/or friction losses in suction line.   |
|   | Pump speed too slow.  | Check engine output; consult engine operation manual.  |
| PUMP REQUIRES TOO MUCH POWER                                  | Pump speed too high.  | Check engine output.   |
|   | Discharge head too low.   | Adjust discharge valve.  |
|   | Liquid solution too thick.                                      | Dilute if possible.  |
|   | Bearing(s) frozen.  | Disassemble pump and check bearing(s).   |
| PUMP CLOGS FREQUENTLY   | Discharge flow too slow.  | Open discharge valve fully to increase flow rate, and run engine at maximum governed speed.  |
|   | Liquid solution too thick.                                      | Dilute if possible.  |
|   | Discharge line clogged or restricted; hose kinked.              | Check discharge lines; straighten hose.  |
| EXCESSIVE NOISE   | Cavitation in pump.   | Reduce suction lift and/or friction losses in suction line. Record vacuum and pressure gauge readings and consult local representative or factory. |
|   | Pumping entrained air.  | Locate and eliminate source of air bubble.   |
|   | Pump or drive not securely mounted.                             | Secure mounting hardware.  |
|   | Impeller clogged or damaged.                                    | Clean out debris; replace damaged parts.   |

**Table 1. Trouble Shooting Chart (cont.)**

| <b>TROUBLE</b>       | <b>POSSIBLE CAUSE</b>                               | <b>PROBABLE REMEDY</b>                                       |
|----------------------|---|--|
| BEARINGS RUN TOO HOT | Bearing temperature is high, but within limits.     | Check bearing temperature regularly to monitor any increase. |
|                      | Low or incorrect lubricant.                         | Check for proper type and level of lubricant.                |
|                      | Suction and discharge lines not properly supported. | Check piping installation for proper support.                |
|                      | Drive misaligned.                                   | Align drive properly.  |

## PREVENTIVE MAINTENANCE

Since pump applications are seldom identical, and pump wear is directly affected by such things as the abrasive qualities, pressure and temperature of the liquid being pumped, this section is intended only to provide general recommendations and practices for preventive maintenance. Regardless of the application however, following a routine preventive maintenance schedule will help assure trouble-free performance and long life from your Gorman-Rupp pump. For specific questions concerning your application, contact your Gorman-Rupp distributor or the Gorman-Rupp Company.

Record keeping is an essential component of a good preventive maintenance program. Changes in suction and discharge gauge readings (if so

equipped) between regularly scheduled inspections can indicate problems that can be corrected before system damage or catastrophic failure occurs. The appearance of wearing parts should also be documented at each inspection for comparison as well. Also, if records indicate that a certain part (such as the seal) fails at approximately the same duty cycle, the part can be checked and replaced before failure occurs, reducing unscheduled down time.

For new applications, a first inspection of wearing parts at 250 hours will give insight into the wear rate for your particular application. Subsequent inspections should be performed at the intervals shown on the chart below. Critical applications should be inspected more frequently.

| <b>Preventive Maintenance Schedule</b>  |                   |        |         |               |          |
|---|-------------------|--------|---------|---------------|----------|
| Item  | Service Interval* |        |         |               |          |
|   | Daily             | Weekly | Monthly | Semi-Annually | Annually |
| General Condition (Temperature, Unusual Noises or Vibrations, Cracks, Leaks, Loose Hardware, Etc.)  | I                 |        |         |               |          |
| Pump Performance (Gauges, Speed, Flow)  | I                 |        |         |               |          |
| Bearing Lubrication   |                   | I      |         |               | R        |
| Seal Lubrication (And Packing Adjustment, If So Equipped)   |                   | I      |         |               | R        |
| V-Belts (If So Equipped)  |                   |        | I       |               |          |
| Air Release Valve Plunger Rod (If So Equipped)  |                   |        | I       | C             |          |
| Front Impeller Clearance (Wear Plate)   |                   |        |         | I             |          |
| Rear Impeller Clearance (Seal Plate)  |                   |        |         | I             |          |
| Check Valve   |                   |        |         |               | I        |
| Pressure Relief Valve (If So Equipped)  |                   |        |         |               | C        |
| Pump and Driver Alignment   |                   |        |         |               | I        |
| Shaft Deflection  |                   |        |         |               | I        |
| Bearings  |                   |        |         |               | I        |
| Bearing Housing   |                   |        |         |               | I        |
| Piping  |                   |        |         |               | I        |
| Driver Lubrication – See Mfgr’s Literature  |                   |        |         |               | I        |
| <p>Legend:<br/>                     I = Inspect, Clean, Adjust, Repair or Replace as Necessary<br/>                     C = Clean<br/>                     R = Replace</p> <p>* Service interval based on an intermittent duty cycle equal to approximately 4000 hours annually. Adjust schedule as required for lower or higher duty cycles or extreme operating conditions.</p> |                   |        |         |               |          |

## PUMP MAINTENANCE AND REPAIR - SECTION E

**MAINTENANCE AND REPAIR OF THE WEARING PARTS OF THE PUMP WILL MAINTAIN PEAK OPERATING PERFORMANCE.**

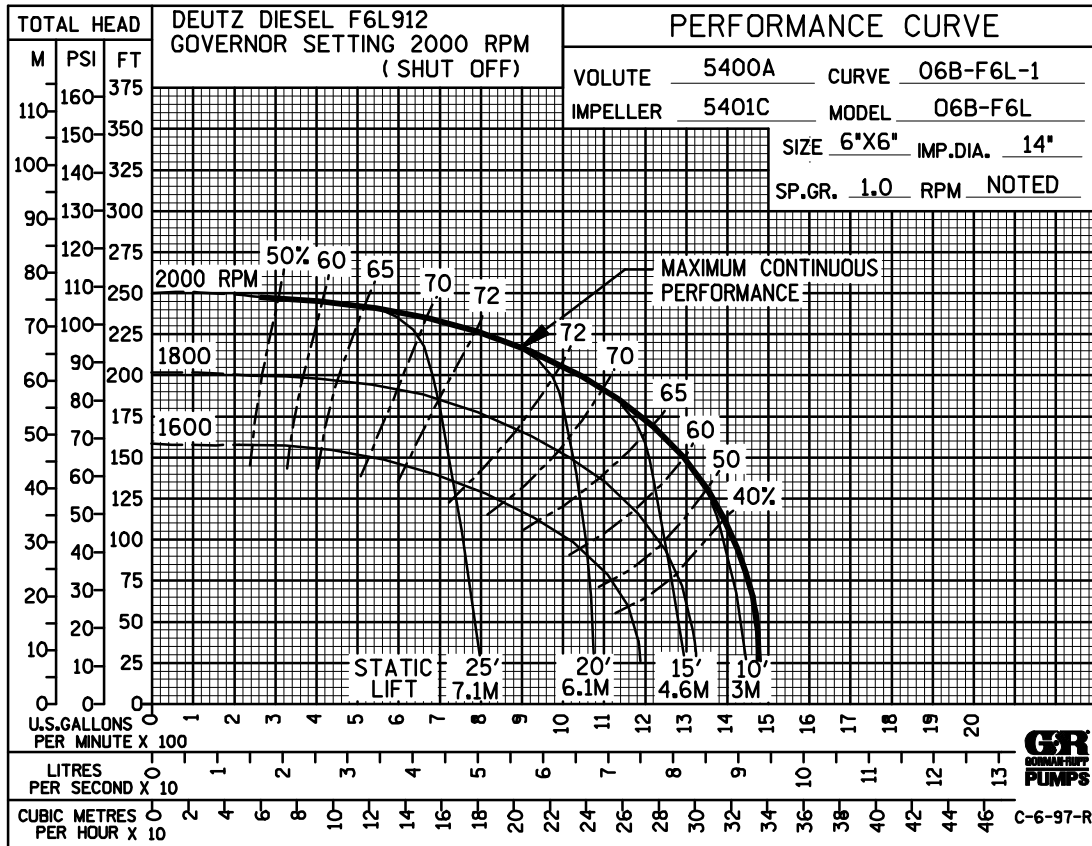

\* STANDARD PERFORMANCE FOR PUMP MODEL O6B3-F6L

\* Based on 70° F (21° C) clear water at sea level with minimum suction lift. Since pump installations are seldom identical, your performance may be different due to such factors as viscosity, specific gravity, elevation, temperature, and impeller trim.

If your pump serial number is followed by an "N", your pump is **NOT** a standard production model. Contact the Gorman-Rupp Company to verify performance or part numbers.



# WARNING!

**Never tamper with the governor to gain more power. The governor establishes safe operating limits that should not be exceeded. The maximum continuous operating speed for this pump is 2000 RPM.**

SECTION DRAWING

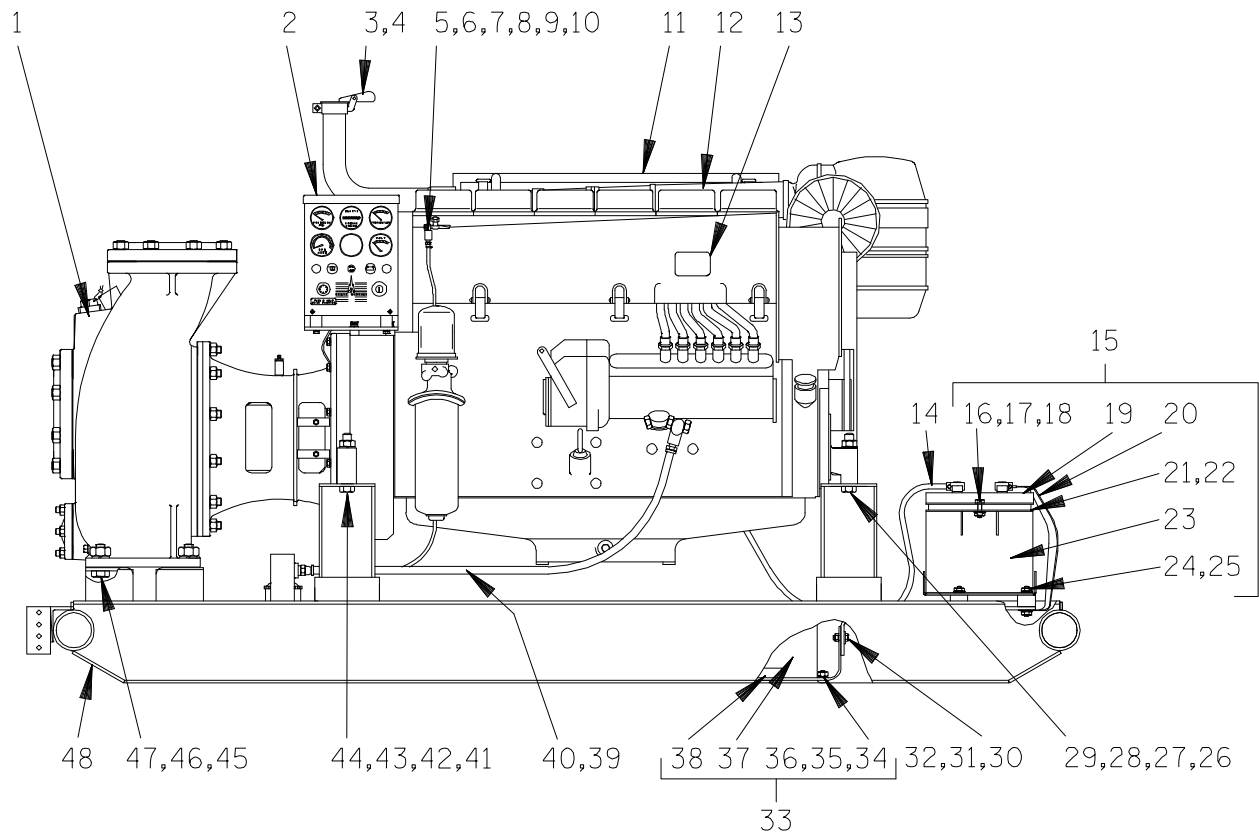

Figure 1. Pump Model 06B3-F6L

**PARTS LIST**  
**Pump Model 06B3—F6L**  
 (From S/N 1124544 up)

If your pump serial number is followed by an “N”, your pump is **NOT** a standard production model. Contact the Gorman-Rupp Company to verify part numbers.

| ITEM NO. | PART NAME          | PART NUMBER | MAT'L CODE | QTY | ITEM NO.             | PART NAME            | PART NUMBER | MAT'L CODE | QTY |
|----------|--------------------|-------------|------------|-----|----------------------|----------------------|-------------|------------|-----|
| 1        | PUMP END ASSY      | 06B3—(F6L)  | ----       | 1   | 31                   | FLAT WASHER          | K06         | 15991      | 10  |
| 2        | CONTROL PANEL      | 29277—012   | ----       | 1   | 32                   | HEX NUT W/FLG        | 21765—314   | ----       | 10  |
| 3        | EXHAUST ELBOW ASSY | 31912—036   | 15210      | 1   | 33                   | FUEL TANK & GRD ASSY | 46711—041   | ----       | 1   |
| 4        | WEATHER CAP        | S1387       | ----       | 1   | 34                   | —FLAT WASHER         | K06         | 15991      | 6   |
| 5        | FUEL RETURN LINE   | 11308A      | ----       | 1   | 35                   | —CARRIAGE BOLT       | AB0604      | 15991      | 6   |
| 6        | HOSE CLAMP         | 26518—641   | ----       | 2   | 36                   | —HEX NUT W/FLG       | 21765—314   | ----       | 6   |
| 7        | HOSE BARB FITTING  | 26523—443   | ----       | 1   | 37                   | —FUEL TANK ASSY      | 46711—042   | 24150      | 1   |
| 8        | MALE CONNECTOR     | 26523—382   | ----       | 1   | 38                   | —FUEL TANK GRD       | 34851—178   | 15080      | 1   |
| 9        | RED ELBOW          | Q0402       | 11999      | 1   | 39                   | HOSE ASSY            | 46341—801   | ----       | 1   |
| 10       | FUEL RETURN        | 14294       | 24030      | 1   | 40                   | MALE CONNECTOR       | S1447       | ----       | 1   |
| 11       | MUFFLER GRD ASSY   | 42331—035   | ----       | 1   | 41                   | HEX HD CAPSCREW      | B0815       | 15991      | 2   |
| 12       | DEUTZ F6L ENGINE   | 29217—111   | ----       | 1   | 42                   | FLAT WASHER          | K08         | 15991      | 2   |
| 13       | CAUTION DECAL      | 2613FJ      | ----       | 1   | 43                   | LOCK WASHER          | J08         | 15991      | 2   |
| 14       | CABLE ASSY 48”     | 47311—114   | ----       | 1   | 44                   | HEX NUT              | D08         | 15991      | 2   |
| 15       | BATTERY BOX ASSY   | GRP40—08C   | ----       | 1   | 45                   | HEX HD CAPSCREW      | B1209       | 15991      | 4   |
| 16       | —HEX HD CAPSCREW   | B0607       | 15991      | 2   | 46                   | LOCK WASHER          | J12         | 15991      | 4   |
| 17       | —FLAT WASHER       | K06         | 15991      | 2   | 47                   | HEX NUT              | D12         | 15991      | 4   |
| 18       | —HEX NUT W/FLG     | 21765—314   | ----       | 2   | 48                   | COMB BASE            | 41566—675   | 24150      | 1   |
| 19       | —BATT BOX LID ASSY | 42113—012   | 24150      | 1   |                      |                      |             |            |     |
| 20       | —GRND CABLE ASSY   | 47311—064   | ----       | 1   |                      |                      |             |            |     |
| 21       | —12V BATTERY       | SEE OPTIONS |            | 1   |                      |                      |             |            |     |
| 22       | —BATTERY TAG       | 38818—506   | ----       | 1   | NOT SHOWN:           |                      |             |            |     |
| 23       | —BATT BOX ASSY     | 42431—030   | 24150      | 1   | WARNING DECAL        | 2613FE               | ----        |            | 1   |
| 24       | —STUD MOUNT        | 24631—006   | ----       | 4   |                      |                      |             |            |     |
| 25       | —HEX NUT W/FLG     | 21765—314   | ----       | 8   | OPTIONS:             |                      |             |            |     |
| 26       | HEX HD CAPSCREW    | B0815       | 15991      | 2   | * 12V BATTERY        | 29331—506            | ----        |            | 1   |
| 27       | FLAT WASHER        | K08         | 15991      | 2   | WHEEL KIT            | GRP30—248G           | ----        |            | 1   |
| 28       | LOCK WASHER        | J08         | 15991      | 2   | REP MUFFLER GRD ASSY | 42331—050            | ----        |            | 1   |
| 29       | HEX NUT            | D08         | 15991      | 2   | HIGHWAY TRAILER      |                      |             |            |     |
| 30       | HEX HD CAPSCREW    | B0604       | 15991      | 10  | —BALL COUPLER        | 41583—691            | ----        |            | 1   |
|          |                    |             |            |     | —PINTLE EYE          | 41583—701            | ----        |            | 1   |

\* INDICATES PARTS RECOMMENDED FOR STOCK

SECTION DRAWING

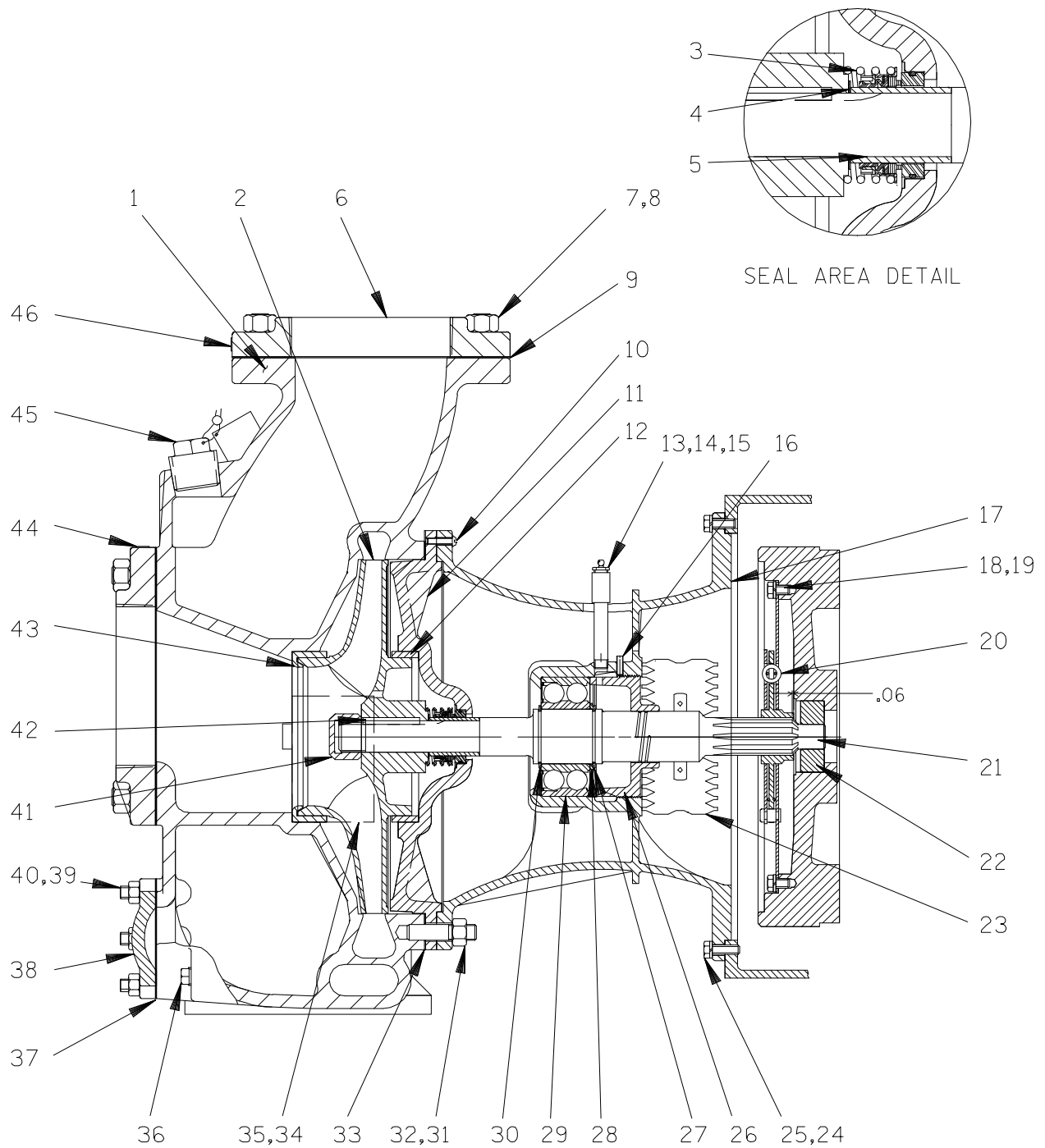

Figure 2. Pump End Assembly 06B3-(F6L)



**PARTS LIST**  
**Pump End Assembly 06B3-(F6L)**

| ITEM NO. | PART NAME         | PART NUMBER | MAT'L CODE | QTY | ITEM NO. | PART NAME          | PART NUMBER | MAT'L CODE | QTY |
|----------|-------------------|-------------|------------|-----|----------|--------------------|-------------|------------|-----|
| 1        | PUMP CASING       | 5400A       | 10010      | 1   | 24       | HEX HD CAPSCREW    | 22645-164   | ----       | 12  |
| 2 *      | IMPELLER          | 5401C       | 14000      | 1   | 25       | LOCKWASHER         | 21171-511   | ----       | 12  |
| 3 *      | SEAL ASSY         | 25271-207   | ----       | 1   | 26       | BRG RETAINING NUT  | 4329        | 10010      | 1   |
| 4 *      | IMP ADJ SHIM SET  | 37J         | 17090      | 1   | 27       | BRG RETAINING RING | S215        | ----       | 1   |
| 5 *      | SHAFT SLEEVE      | 5827        | 16000      | 1   | 28       | SPACER             | 31134-099   | 15010      | 1   |
| 6        | FLANGE            | 1758        | 10010      | 2   | 29 *     | BALL BEARING       | 23423-472   | ----       | 1   |
| 7        | STUD              | C1211       | 15991      | 16  | 30       | BRG RETAINING RING | S215        | ----       | 1   |
| 8        | HEX NUT           | D12         | 15991      | 16  | 31       | STUD               | C1010       | 15991      | 12  |
| 9 *      | DISCH FLANGE GSKT | 1679GC      | 20000      | 2   | 32       | HEX NUT            | D10         | 15991      | 12  |
| 10       | RD HD MACH SCREW  | X0404       | 17090      | 2   | 33 *     | CASING GSKT        | 4820G       | 20000      | 1   |
| 11       | SEAL PLATE        | 5792        | 10010      | 1   | 34       | NAME PLATE         | 38818-018   | 13990      | 1   |
| 12 *     | WEAR RING         | 5404B       | 10030      | 1   | 35       | DRIVE SCREW        | BM#04-03    | 17000      | 4   |
| 13       | LUBE FITTING      | S191        | ----       | 1   | 36       | PIPE PLUG          | P06         | 15079      | 1   |
| 14       | PIPE COUPLING     | AE04        | 15079      | 1   | 37 *     | COVER PLATE GSKT   | 4822G       | 20040      | 1   |
| 15       | PIPE NIPPLE       | T0412       | 15079      | 1   | 38       | COVER PLATE        | 4822        | 10010      | 1   |
| 16       | ALLEN HD SETSCREW | GA0403      | 15990      | 1   | 39       | STUD               | C0807       | 15991      | 6   |
| 17       | INTERMEDIATE BRKT | 7765A       | 10010      | 1   | 40       | HEX NUT            | D08         | 15991      | 6   |
| 18       | SOC HD CAPSCREW   | 22644-215   | ----       | 8   | 41 *     | IMPELLER NUT       | 5667        | 14000      | 1   |
| 19       | LOCKWASHER        | 21171-511   | ----       | 8   | 42       | KEY                | N0409       | 15990      | 1   |
| 20       | DRIVE PLATE ASSY  | 24521-165   | ----       | 1   | 43 *     | WEAR RING          | 5404C       | 10030      | 1   |
| 21 *     | IMPELLER SHAFT    | 12926       | 16040      | 1   | 44       | SUCTION STICKER    | 6588AG      | ----       | 1   |
| 22       | PILOT BUSHING     | 8312A       | 15010      | 1   | 45       | FILL PLUG ASSY     | 48271-067   | ----       | 1   |
| 23       | INTERM GUARD ASSY | 42381-504   | ----       | 2   | 46       | DISCHARGE STICKER  | 6588BJ      | ----       | 1   |

\* INDICATES PARTS RECOMMENDED FOR STOCK

## PUMP AND SEAL DISASSEMBLY AND REASSEMBLY

Review all SAFETY information in Section A.

Follow the instructions on all tags, label and decals attached to the pump.

This pump requires little service due to its rugged, minimum-maintenance design. However, if it becomes necessary to inspect or replace the wearing parts, follow these instructions which are keyed to the sectional views (see Figures 1 and 2) and the accompanying parts lists.

As described on the following pages, this manual will alert personnel to known procedures which require special attention, to those which could damage equipment, and to those which could be dangerous to personnel. However, this manual cannot possibly anticipate and provide detailed precautions for every situation that might occur during maintenance of the unit. Therefore, it is the responsibility of the owner/maintenance personnel to ensure that **only** safe, established maintenance procedures are used, and that any procedures not addressed in this manual are performed **only** after establishing that neither personal safety nor pump integrity are compromised by such practices.

Before attempting to service the pump, switch off the engine ignition and disconnect the positive battery cable to ensure that the pump will remain inoperative. Close all valves in the suction and discharge lines.

For engine disassembly and repair, consult the literature supplied with the engine, or contact your local Deutz engine representative.



**Before attempting to open or service the pump:**

1. **Familiarize yourself with this manual.**
2. **Switch off the engine ignition and disconnect the positive battery**

**cable to ensure that the pump will remain inoperative.**

3. **Allow the pump to completely cool if overheated.**
4. **Check the temperature before opening any covers, plates, or plugs.**
5. **Close the suction and discharge valves.**
6. **Vent the pump slowly and cautiously.**
7. **Drain the pump.**

### Pump Disassembly

(Figure 2)

Before attempting to service the pump, remove the pump casing drain plug (36) and drain the pump. Clean and reinstall the drain plug.

To service the wear ring (43), impeller (2), seal assembly (3), or seal plate (11), the pump casing (1) must be separated from the base and intermediate (17).

Remove the suction and discharge lines. Remove the hardware (45, 46, and 47, Figure 1) securing the casing to the base (48). Remove the hardware (32) and use a suitable hoist and sling to separate the pump casing and gasket (33) from the seal plate (11) and intermediate (17).

Tie and tag any leveling shims used under the casing feet to ease reassembly.



**Use lifting and moving equipment in good repair and with adequate capacity to prevent injuries to personnel or damage to equipment. Suction and discharge hoses and piping must be removed from the pump before lifting.**

Inspect the wear ring (43) for excessive wear or scoring. The wear ring is secured in the pump casing by a press fit, and if replacement is required, use a suitable puller to remove it.

## Impeller Removal

### (Figure 2)

Remove the impeller nut (41). Install three 3/8 - 16 UNC capscrews (not supplied) into the impeller hub and use a gear puller to slide the impeller off the shaft. Use caution not to damage the impeller.

Disengage the impeller key (42) and remove the impeller adjusting shims (4). Tie and tag the shims or measure and record their thickness for ease of reassembly.

Inspect the wear ring (43) and remove it if badly worn or damaged. The wear ring is secured by a press fit. If replacement is required, use a small bit to drill two holes through the ring horizontally, 180° apart. Use a saw and chisel to complete the cuts through the ring, and remove it from the casing. **Use caution** not to damage the pump casing when removing the ring.

## Seal Removal and Disassembly

### (Figure 2)

Remove the spring, shaft sleeve (5), retainer, bellows, and rotating element.

Remove the machine screw (10) and slide the seal plate and stationary element off the impeller shaft as a unit. Press the stationary seal element with O-ring out of the seal plate.

Inspect the wear ring (12) for excessive wear or damage. If replacement is required, use a suitable puller to remove it from the seal plate.

## Separating Intermediate From Engine

### (Figure 2)

To service the shaft (21) and bearings (29) or drive assembly, the intermediate (17) must be separated from the engine.

Support the intermediate using a suitable sling, and remove the hardware (24 and 25) securing it to the engine bellhousing. Separate the assemblies by pulling the intermediate straight away from the engine. As the assemblies separate, the impeller

shaft (21) will disengage from the drive plate assembly (20).

It is not necessary to remove the drive plate assembly from the engine flywheel unless the assembly or pilot bushing (22) must be replaced. To remove the drive plate assembly, disengage the hardware (18 and 19).

Inspect the pilot bushing for excessive wear or damage. If replacement is required, use a suitable puller to remove the pilot bushing from the flywheel.

## Shaft and Bearing Removal and Disassembly

### (Figure 2)

When the pump is properly operated and maintained, the shaft and bearing should not require disassembly. Disassemble the shaft and bearings **only** when there is evidence of wear or damage.



Shaft and bearing disassembly in the field is not recommended. These operations should be performed only in a properly equipped shop by qualified personnel.

After separating the intermediate from the engine, loosen the setscrews (16) and unscrew the bearing retainer nut (26) from the intermediate.

### NOTE

*There are no provisions for draining the grease from the intermediate cavity. Place a drip pan under the intermediate before removing the shaft and bearing.*

Place a block of wood against the impeller end of the shaft (21), and tap the shaft and assembled bearings (29) from the bearing bore. **Be careful** not to damage the shaft threads.

Remove the inboard bearing retaining ring (30) and press the bearing (29) from the shaft. It is not necessary to remove the outboard bearing retaining ring (27) from the shaft unless replacement is required. Remove the bearing spacer (28).

After removing the shaft and bearings, clean and inspect the bearings **in place** as follows.

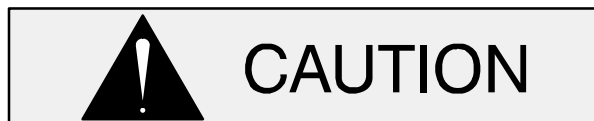

To prevent damage during removal from the shaft, it is recommended that bearings be cleaned and inspected **in place**. It is **strongly** recommended that the bearings be replaced **any** time the shaft and bearings are removed.

Clean the intermediate, shaft and all component parts (except the bearings) with a soft cloth soaked in cleaning solvent. Inspect the parts for wear or damage and replace as necessary.



**Most cleaning solvents are toxic and flammable. Use them only in a well ventilated area free from excessive heat, sparks, and flame. Read and follow all precautions printed on solvent containers.**

Clean the bearings thoroughly in **fresh** cleaning solvent. Dry the bearings with filtered compressed air and coat with light oil.



Bearings must be kept free of all dirt and foreign material. Failure to do so will greatly shorten bearing life. **Do not** spin dry bearings. This may scratch the balls or races and cause premature bearing failure.

Rotate the bearings by hand to check for roughness or binding and inspect the bearing balls. If rotation is rough or the bearing balls are discolored, replace the bearings.

The bearing tolerances provide a tight press fit onto the shaft and a snug slip fit into the intermedi-

ate. Replace the bearings, shaft, or intermediate if the proper bearing fit is not achieved.

### Shaft and Bearing Reassembly and Installation

Clean and inspect the bearings as indicated in **Shaft and Bearing Removal and Disassembly**.

Inspect the shaft for distortion, nicks or scratches or thread damage on the impeller end. Dress small nicks and burrs with a fine file or emery cloth. Replace the shaft if defective.

Install the outboard bearing retaining ring (27) if it was removed. Replace the bearing spacer (28).

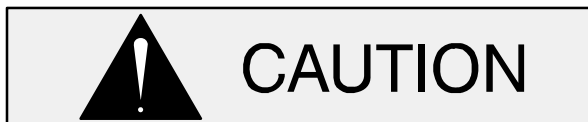

To prevent damage during removal from the shaft, it is recommended that bearings be cleaned and inspected **in place**. It is **strongly** recommended that the bearings be replaced **any** time the shaft and bearings are removed.

The bearings may be heated to ease installation. An induction heater, hot oil bath, electric oven, or hot plate may be used to heat the bearings. Bearings should **never** be heated with a direct flame or directly on a hot plate.

### NOTE

*If a hot oil bath is used to heat the bearings, both the oil and the container must be **absolutely** clean. If the oil has been previously used, it must be **thoroughly** filtered.*

Heat the bearings to a uniform temperature **no higher than 250°F (120°C)**, and slide the bearings onto the shaft, one at a time, until they are fully seated. This should be done quickly, in one continuous motion, to prevent the bearings from cooling and sticking on the shaft.



**Use caution when handling hot bearings to prevent burns.**

### NOTE

*Position the bearing (29) on the shaft with the*

shielded side **toward** the impeller.

After the bearings have been installed and allowed to cool, check to ensure that they have not moved away from the shaft shoulders in shrinking. If movement has occurred, use a suitable sized sleeve and a press to reposition the bearings against the shaft shoulders.

If heating the bearings is not practical, use a suitable sized sleeve and an arbor (or hydraulic) press to install the bearings on the shaft.



When installing the bearings onto the shaft, **never** press or hit against the outer race, balls, or ball cage. Press **only** on the inner race.

Pre-pack the bearing by hand (or use a bearing packer if available) with No. 0 lithium base grease until the bearing balls are thoroughly lubricated. Secure the bearing on the shaft with the inboard bearing retaining ring (30).

Slide the shaft and assembled bearings into the intermediate bore from the drive end until the bearing seats squarely against the bore shoulder.



When installing the shaft and bearings into the bearing bore, push against the outer race. **Never** hit the balls or ball cage.

Screw the bearing retaining nut (26) into the intermediate and check the shaft endplay. Adjust the bearing retaining nut to establish the correct endplay.

#### NOTE

*Impeller shaft endplay should be between .002 and .010 inch (0,05 mm to 0,25 mm). Adjust the bearing retaining nut to obtain the correct endplay. Secure the bearing retaining nut with setscrew (16).*

Lubricate the bearing cavity as indicated in **LUBRICATION** at the end of this section.

## Securing Intermediate To Engine

### (Figure 2)

Apply a thin coating of 'Never-Seez' lubricant to the inside diameter of the pilot bushing (22) and press it into the flywheel until fully seated.

Secure the drive plate assembly to the flywheel with the hardware (18 and 19).

Slide the shaft splines into the drive plate and secure the intermediate assembly to the engine bellhousing with the hardware (24 and 25).



If the flywheel bushing and drive plate are not properly positioned on the shaft, excessive wear and a preload condition could cause premature bearing failure.

## Seal Reassembly and Installation

### (Figures 2 and 3)

Clean the seal cavity and shaft with a cloth soaked in fresh cleaning solvent.



**Most cleaning solvents are toxic and flammable. Use them only in a well-ventilated area free from excessive heat, sparks, and flame. Read and follow all precautions printed on solvent containers.**

The seal is not normally reused because wear patterns on the finished faces cannot be realigned during reassembly. This could result in premature failure. If necessary to reuse an old seal in an emergency, **carefully** wash all metallic parts in fresh cleaning solvent and allow to dry thoroughly.

Handle the seal parts with extreme care to prevent damage. Be careful not to contaminate precision finished faces; even fingerprints on the faces can shorten seal life. If necessary, clean the faces with a non-oil based solvent and a clean, lint-free tissue. Wipe **lightly** in a concentric pattern to avoid scratching the faces.

Inspect the seal components for wear, scoring, grooves, and other damage that might cause leakage. Clean and polish the shaft sleeve, or replace it if there are nicks or cuts on either end. If any components are worn, replace the complete seal; **never mix old and new seal parts.**

If a replacement seal is being used, remove it from the container and inspect the precision finished

faces to ensure that they are free of any foreign matter.

To ease installation of the seal, lubricate the bellows and O-rings with water or a very **small** amount of light lubricating oil, and apply a drop of light lubricating oil on the finished faces. Assemble the seal as follows, (see Figure 3).

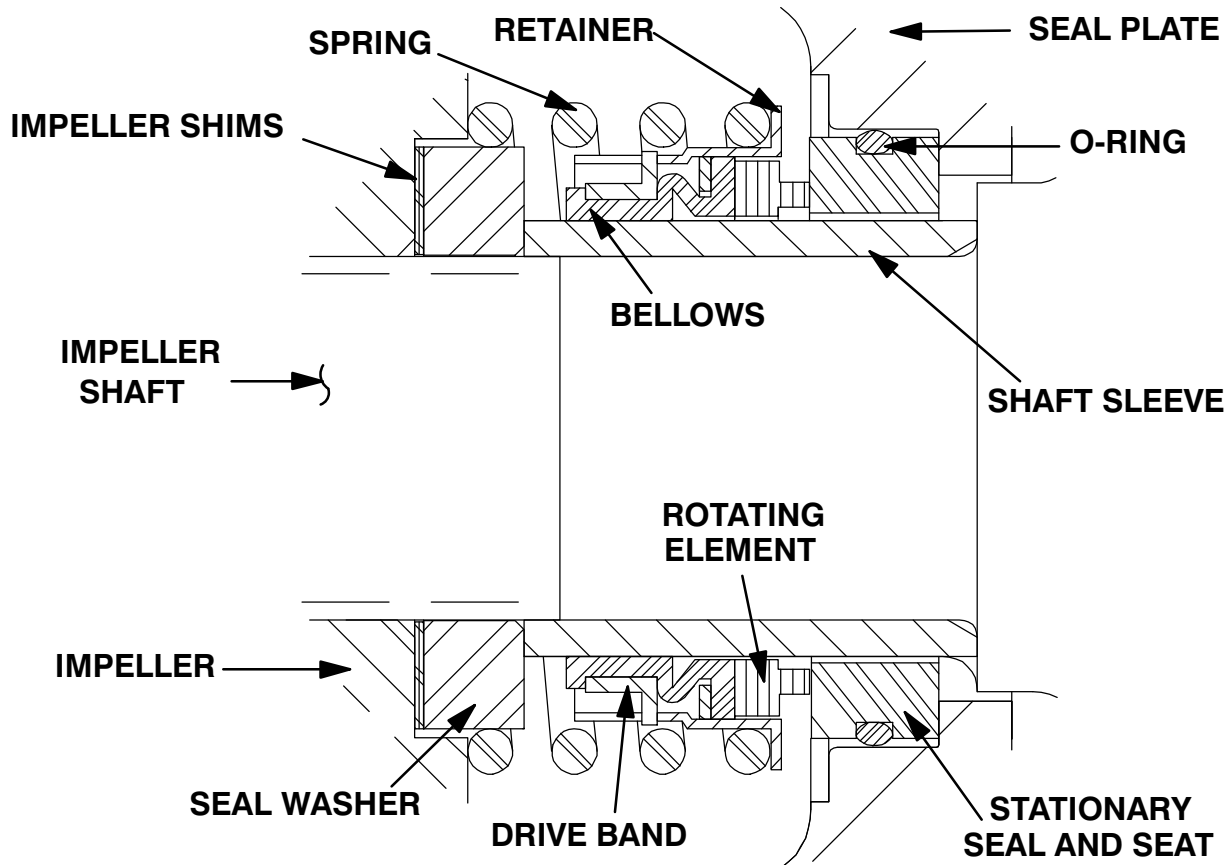

Figure 3. 25271-207 Seal Assembly



This seal is not designed for operation at temperatures above 160°F (71°C). Do not use at higher operating temperatures.

Lay the seal plate (11) on a flat surface with the impeller side facing up. If the wear ring (12) was removed, press the replacement ring into the seal plate until it seats squarely against the bore shoulder.



The wear ring **must** seat squarely in the seal plate bore or binding and/or excessive wear will result.

Subassemble the O-ring onto the stationary element and use even pressure to press this subassembly into the seal plate until it seats squarely against the shoulder bore. Position the shaft sleeve (5) through the I.D. of the stationary element with the chamfered end down.

Subassemble the rotating element into the retainer and bellows and slide this subassembly over the shaft sleeve until the polished faces contact.

Carefully slide the assembled seal plate, sleeve and seal over the shaft. Secure the seal plate to the intermediate with the round head machine screws (10). Install the seal spring.

**Impeller Installation**

(Figure 2)

Inspect the impeller, and replace it if cracked or badly worn.

Install the same thickness of impeller shims (4) as previously removed onto the shaft. Install the impeller key (42) and press the impeller on the shaft until fully seated.

For maximum pump efficiency, the impeller should be centered within the volute scroll.

To verify the impeller positioning, measure the pump casing and impeller as shown in Figure 4. Use these measurements to calculate the required impeller location (dimension E). Add or remove impeller adjusting shims until dimension E is obtained.

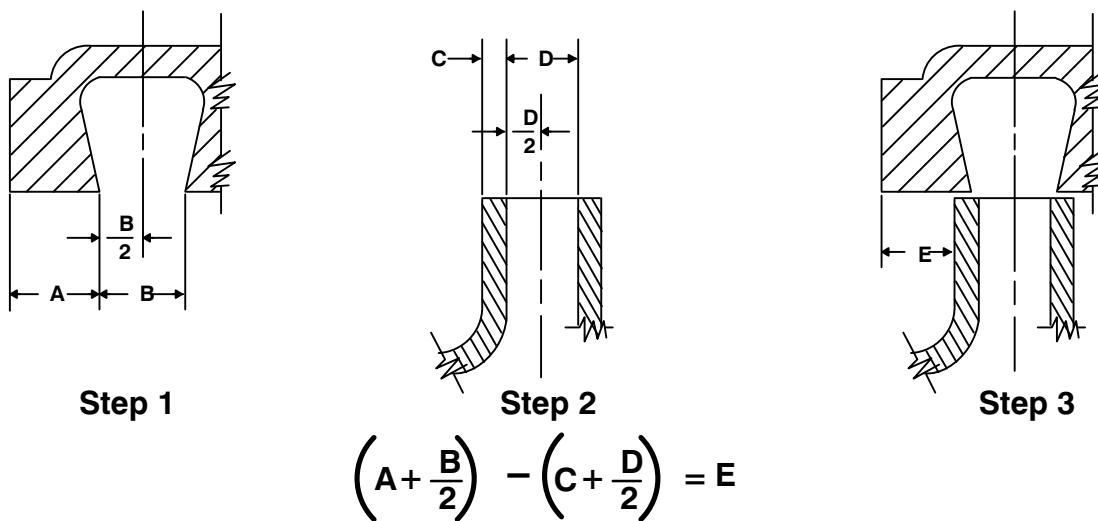

Figure 4. Centering Impeller Within Volute Scroll

**NOTE**

After the impeller has been properly positioned, check for free rotation. Correct any scraping binding before further reassembly.



The wear ring **must** seat squarely in the casing bore or binding and/or excessive wear will result.

Screw the impeller nut (41) onto the shaft until tight.

Install the casing gasket (33) and secure the casing to the seal plate and intermediate with the hardware (32). Reinstall any leveling shims under the casing mounting feet and secure the casing to the base (48) with the hardware (45, 46 and 47, Figure 1).

**Pump Reassembly**

(Figure 2)

If removed at disassembly, press the replacement wear ring (43) into the casing until it seats squarely against the shoulder bore.

**Final Pump Assembly**

(Figure 1)

**Be sure** the pump and engine are securely mounted to the base.

Install the suction and discharge lines and open all valves. Make certain that all piping connections are tight, properly supported and secure.

**Be sure** the pump, intermediate and engine have been properly lubricated, see **LUBRICATION**.

Fill the pump casing with clean liquid. Reinstall the fill plug and tighten it.

Refer to **OPERATION**, Section C, before putting the pump back into service.

## LUBRICATION

### Seal Assembly

The seal assembly is lubricated by the medium being pumped and no additional lubrication is required.

### Bearings

#### (Figure 2)

The intermediate was fully lubricated when shipped from the factory. Under normal conditions, add three shots of No. 0 lithium base grease from a grease gun through the grease fitting (13) after each 250 hours of operation or once each month, whichever comes first. **Do not** over-lubricate. Over-lubrication can cause the bearings to over-heat, resulting in premature bearing failure.



If grease is forced out around the shaft as new grease is added, the bearing cavity is full and should be disassembled and cleaned immediately.

There are no provisions in the bearing cavity to drain or flush the lubricant. The pump and intermediate must be disassembled to completely clean and maintain this cavity.

Under normal conditions, change the grease after each 5000 hours of operation, or at 12 month intervals, whichever comes first. Change the grease more frequently if the pump is operated continuously or installed in an environment where variable hot and cold temperatures are common.

When lubricating a dry (overhauled) intermediate, fill the cavity through the lubrication fitting with approximately one-third of a pound of grease (approximately one-third full).

For cold weather operation, consult the factory or a lubricant supplier for the recommended grade of lubricant.

### Engine

Consult the literature supplied with the engine, or contact your local Deutz engine representative.



**For U.S. and International Warranty Information,  
Please Visit [www.grpumps.com/warranty](http://www.grpumps.com/warranty)  
or call:  
U.S.: 419-755-1280  
International: +1-419-755-1352**

**For Canadian Warranty Information,  
Please Visit [www.grcanada.com/warranty](http://www.grcanada.com/warranty)  
or call:  
519-631-2870**