

**INSTALLATION, OPERATION,
AND MAINTENANCE MANUAL**
WITH PARTS LIST



80 SERIES PUMPS

<p>MODEL</p>
<p>88A2—F6L</p>

THE GORMAN-RUPP COMPANY • MANSFIELD, OHIO

www.gormanrupp.com

GORMAN-RUPP OF CANADA LIMITED • ST. THOMAS, ONTARIO, CANADA

Printed in U.S.A.

©Copyright by the Gorman-Rupp Company



The engine exhaust from this product contains chemicals known to the State of California to cause cancer, birth defects or other reproductive harm.

TABLE OF CONTENTS

INTRODUCTION	PAGE I – 1
SAFETY - SECTION A	PAGE A – 1
INSTALLATION – SECTION B	PAGE B – 1
Pump Dimensions	PAGE B – 1
PREINSTALLATION INSPECTION	PAGE B – 2
Battery Specifications And Installation	PAGE B – 2
POSITIONING PUMP	PAGE B – 2
Lifting	PAGE B – 2
Mounting	PAGE B – 3
SUCTION AND DISCHARGE PIPING	PAGE B – 3
Materials	PAGE B – 3
Line Configuration	PAGE B – 3
Connections to Pump	PAGE B – 3
Gauges	PAGE B – 3
SUCTION LINES	PAGE B – 3
Fittings	PAGE B – 3
Strainers	PAGE B – 3
Sealing	PAGE B – 3
Suction Lines In Sumps	PAGE B – 4
Suction Line Positioning	PAGE B – 4
DISCHARGE LINES	PAGE B – 5
Siphoning	PAGE B – 5
Valves	PAGE B – 5
Bypass Lines	PAGE B – 5
ALIGNMENT	PAGE B – 5
OPERATION – SECTION C	PAGE C – 1
PRIMING	PAGE C – 1
STARTING	PAGE C – 2
OPERATION	PAGE C – 2
Lines With a Bypass	PAGE C – 2
Lines Without a Bypass	PAGE C – 2
Leakage	PAGE C – 2
Liquid Temperature And Overheating	PAGE C – 3
Strainer Check	PAGE C – 3
Pump Vacuum Check	PAGE C – 3
STOPPING	PAGE C – 3
Safety Shutdown System	PAGE C – 3
OPERATION IN EXTREME HEAT	PAGE C – 4
BEARING TEMPERATURE CHECK	PAGE C – 4
Cold Weather Preservation	PAGE C – 4

TABLE OF CONTENTS
(continued)

TROUBLESHOOTING – SECTION D	PAGE D – 1
PREVENTIVE MAINTENANCE	PAGE D – 3
PUMP MAINTENANCE AND REPAIR - SECTION E	PAGE E – 1
PERFORMANCE CURVE	PAGE E – 1
PARTS LISTS:	
Pump Model	PAGE E – 3
Pump End Assembly	PAGE E – 5
Drive Assembly	PAGE E – 6
PUMP AND SEAL DISASSEMBLY AND REASSEMBLY	PAGE E – 7
Suction Check Valve Removal	PAGE E – 7
Separating Pump and Intermediate from Engine	PAGE E – 7
Loosening the Impeller	PAGE E – 8
Pump Casing and Wear Plate Removal	PAGE E – 8
Impeller Removal	PAGE E – 9
Seal Removal	PAGE E – 9
Shaft and Bearing Removal and Disassembly	PAGE E – 9
Shaft and Bearing Reassembly and Installation	PAGE E – 10
Seal Reassembly and Installation	PAGE E – 11
Impeller Installation	PAGE E – 13
Securing Intermediate and Drive Assembly to Engine	PAGE E – 13
Pump Casing and Wear Plate Installation	PAGE E – 14
Suction Check Valve Installation	PAGE E – 14
Final Pump Reassembly	PAGE E – 14
LUBRICATION	PAGE E – 14
Seal Assembly	PAGE E – 14
Bearings	PAGE E – 15
Engine	PAGE E – 15

INTRODUCTION

Thank You for purchasing a Gorman-Rupp pump. **Read this manual** carefully to learn how to safely install and operate your pump. Failure to do so could result in personal injury or damage to the pump.

This Installation, Operation, and Maintenance manual is designed to help you achieve the best performance and longest life from your Gorman-Rupp pump.

This pump is an 80 Series, semi-open impeller, self-priming centrifugal model with a suction check valve. The pump is close-coupled to an air-cooled Deutz diesel engine.

The pump is designed for handling most non-volatile, non-flammable liquids containing specified entrained solids. The basic material of construction for all wetted parts is gray iron and steel.

If there are any questions regarding the pump or its application which are not covered in this manual or in other literature accompanying this unit, please contact your Gorman-Rupp distributor, or write:

The Gorman-Rupp Company
P.O. Box 1217
Mansfield, Ohio 44901-1217
Phone: (419) 755-1011
 or:
Gorman-Rupp of Canada Limited
70 Burwell Road
St. Thomas, Ontario N5P 3R7
Phone: (519) 631-2870

For information or technical assistance on the engine, contact the engine manufacturer's local dealer or representative.

Because pump installations are seldom identical, this manual cannot possibly provide detailed instructions and precautions for every aspect of each specific application. Therefore, it is the responsibility of the owner/installer of the pump to ensure that applications not addressed in this manual are performed **only** after establishing that

neither operator safety nor pump integrity are compromised by the installation. Pumps and related equipment **must** be installed and operated according to all national, local and industry standards.

The following are used to alert maintenance personnel to procedures which require special attention, to those which could damage equipment, and to those which could be dangerous to personnel:



Immediate hazards which WILL result in severe personal injury or death. These instructions describe the procedure required and the injury which will result from failure to follow the procedure.



Hazards or unsafe practices which COULD result in severe personal injury or death. These instructions describe the procedure required and the injury which could result from failure to follow the procedure.



Hazards or unsafe practices which COULD result in minor personal injury or product or property damage. These instructions describe the requirements and the possible damage which could result from failure to follow the procedure.

NOTE

Instructions to aid in installation, operation, and maintenance, or which clarify a procedure.

SAFETY – SECTION A

This information applies to 80 Series Engine Driven pumps. Refer to the manual accompanying the engine before attempting to begin operation.

Because pump installations are seldom identical, this manual cannot possibly provide detailed instructions and precautions for each specific application. Therefore, it is the owner/installer's responsibility to ensure that applications not addressed in this manual are performed only after establishing that neither operator safety nor pump integrity are compromised by the installation.



Before attempting to open or service the pump:

1. Familiarize yourself with this manual.
2. Shut down the engine and disconnect the positive battery cable to ensure that the pump will remain inoperative.
3. Allow the pump to completely cool if overheated.
4. Check the temperature before opening any covers, plates, or plugs.
5. Close the suction and discharge valves.
6. Vent the pump slowly and cautiously.
7. Drain the pump.



If the pump is equipped with the optional automatic starting system, it is subject to automatic restart. Keep hands and clothing away from the unit to prevent injury during automatic operation.

Disconnect the positive battery cable before performing any maintenance. Failure to do so may result in serious personal injury.



This pump is designed to handle most non-volatile, non-flammable liquids containing specified entrained solids. Do not attempt to pump volatile, corrosive, or flammable materials, or any liquids which may damage the pump or endanger personnel as a result of pump failure.



Use lifting and moving equipment in good repair and with adequate capacity to prevent injuries to personnel or damage to equipment. Suction and discharge hoses and piping must be removed from the pump before lifting.



After the pump has been positioned, make certain that the pump and all piping or hose connections are tight, properly supported and secure before operation.



Do not operate the pump against a closed discharge valve for long periods of time. If operated against a closed discharge valve, pump components will deteriorate, and the liquid could come to a boil, build pressure, and cause the pump casing to rupture or explode.

**WARNING!**

Do not remove plates, covers, gauges, pipe plugs, or fittings from an overheated pump. Vapor pressure within the pump can cause parts being disengaged to be ejected with great force. Allow the pump to cool before servicing.

**DANGER!**

Do not operate an internal combustion engine in an explosive atmosphere. When operating internal combustion engines in an enclosed area, make certain that exhaust fumes are piped to the outside. These fumes contain carbon monoxide, a deadly gas that is colorless, tasteless, and odorless.

**WARNING!**

Fuel used by internal combustion engines presents an extreme explosion and fire hazard. Make certain that all fuel lines are securely connected and free of leaks. Never refuel a hot or running engine. Avoid overfilling the fuel tank. Always use the correct type of fuel.

**WARNING!**

Never tamper with the governor to gain more power. The governor establishes safe operating limits that should not be exceeded. The maximum continuous operating speed for this pump is 2100 RPM.

INSTALLATION – SECTION B

Review all SAFETY information in Section A.

Since pump installations are seldom identical, this section offers only general recommendations and practices required to inspect, position, and arrange the pump and piping.

Most of the information pertains to a standard **static lift** application where the pump is positioned above the free level of liquid to be pumped.

If installed in a **flooded suction application** where the liquid is supplied to the pump under pressure, some of the information such as mounting, line configuration, and priming must be tailored to the

specific application. Since the pressure supplied to the pump is critical to performance and safety, **be sure** to limit the incoming pressure to 50% of the maximum permissible operating pressure. If the pump is fitted with a Gorman-Rupp double grease lubricated seal, the maximum incoming pressure must be reduced to 10 p.s.i.

For further assistance, contact your Gorman-Rupp distributor or the Gorman-Rupp Company.

Pump Dimensions

See Figure 1 for the approximate physical dimensions of this pump.

OUTLINE DRAWING

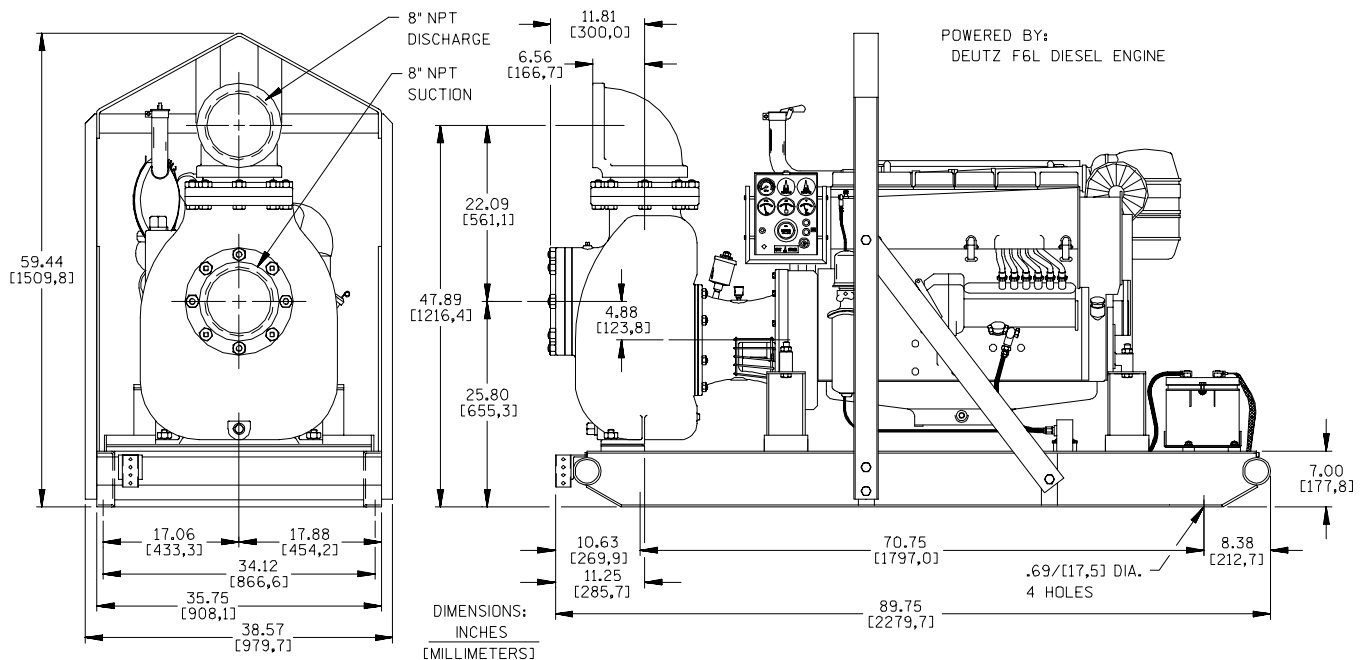

Figure 1. Pump Model 88A2-F6L

PREINSTALLATION INSPECTION

The pump assembly was inspected and tested before shipment from the factory. Before installation, inspect the pump for damage which may have occurred during shipment. Check as follows:

- a. Inspect the pump and engine for cracks, dents, damaged threads, and other obvious damage.
- b. Check for and tighten loose attaching hardware. Since gaskets tend to shrink after drying, check for loose hardware at mating surfaces.
- c. Carefully read all tags, decals, and markings on the pump assembly, and perform all duties indicated.
- d. Check levels and lubricate as necessary. Refer to **LUBRICATION** in the **MAINTENANCE AND REPAIR** section of this manual and perform duties as instructed.
- e. If the pump end has been stored for more than 12 months, some of the components or lubricants may have exceeded their maximum shelf life. These **must be inspected or replaced** to ensure maximum pump service.

If the maximum shelf life has been exceeded, or if anything appears to be abnormal, contact your Gorman-Rupp distributor or the factory to determine the repair or updating policy. **Do not** put the pump into service until appropriate action has been taken.

Battery Specifications And Installation

Unless otherwise specified on the pump order, the engine battery was **not** included with the unit. Refer to the following specifications when selecting a battery.

Table 1. Battery Specifications

Voltage	Cold Crank Amps @ 0°F	Reserve Capacity @80°F (Minutes)	Amp/Hr. Rating	Approx. Overall Dims. (Inches)
12 Volts	960-975	365	175	20.5L x 8.75W x 9.75H

Refer to the information accompanying the battery and/or electrolyte solution for activation and charging instructions.

Before installing the battery, clean the positive and negative cable connectors, and the battery terminals. Secure the battery by tightening the holddown brackets. The terminals and clamps may be coated with petroleum jelly to retard corrosion. Connect and tighten the positive cable first, then the negative cable.

POSITIONING PUMP



WARNING!

Use lifting and moving equipment in good repair and with adequate capacity to prevent injuries to personnel or damage to equipment. Suction and discharge hoses and piping must be removed from the pump before lifting.

Lifting

Pump unit weights will vary depending on the mounting and drive provided. Check the shipping tag on the unit packaging for the actual weight, and use lifting equipment with appropriate capacity. Drain the pump and remove all customer-installed equipment such as suction and discharge hoses or piping before attempting to lift existing, installed units.



CAUTION

The pump assembly can be seriously damaged if the cables or chains used to lift and move the unit are improperly wrapped around the pump.

Mounting

Locate the pump in an accessible place as close as practical to the liquid being pumped. Level mounting is essential for proper operation.

The pump may have to be supported or shimmed to provide for level operation or to eliminate vibration.

If the pump has been mounted on a moveable base, make certain the base is stationary by setting the brake and blocking the wheels before attempting to operate the pump.

To ensure sufficient lubrication and fuel supply to the engine, **do not** position the pump and engine more than 15° off horizontal for continuous operation. The pump and engine may be positioned up to 30° off horizontal for **intermittent operation only**; however, the engine manufacturer should be consulted for continuous operation at angles greater than 15°.

SUCTION AND DISCHARGE PIPING

Pump performance is adversely effected by increased suction lift, discharge elevation, and friction losses. See the performance curve and operating range shown on Page E-1 to be sure your overall application allows pump to operate within the safe operation range.

Materials

Either pipe or hose may be used for suction and discharge lines; however, the materials must be compatible with the liquid being pumped. If hose is used in suction lines, it must be the rigid-wall, reinforced type to prevent collapse under suction. Using piping couplings in suction lines is not recommended.

Line Configuration

Keep suction and discharge lines as straight as possible to minimize friction losses. Make minimum use of elbows and fittings, which substantially increase friction loss. If elbows are necessary, use the long-radius type to minimize friction loss.

Connections to Pump

Before tightening a connecting flange, align it exactly with the pump port. Never pull a pipe line into place by tightening the flange bolts and/or couplings.

Lines near the pump must be independently supported to avoid strain on the pump which could cause excessive vibration, decreased bearing life, and increased shaft and seal wear. If hose-type lines are used, they should have adequate support to secure them when filled with liquid and under pressure.

Gauges

Most pumps are drilled and tapped for installing discharge pressure and vacuum suction gauges. If these gauges are desired for pumps that are not tapped, drill and tap the suction and discharge lines not less than 18 inches (457 mm) from the suction and discharge ports and install the lines. Installation closer to the pump may result in erratic readings.

SUCTION LINES

To avoid air pockets which could affect pump priming, the suction line must be as short and direct as possible. When operation involves a suction lift, the line must always slope upward to the pump from the source of the liquid being pumped; if the line slopes down to the pump at any point along the suction run, air pockets will be created.

Fittings

Suction lines should be the same size as the pump inlet. If reducers are used in suction lines, they should be the eccentric type, and should be installed with the flat part of the reducers uppermost to avoid creating air pockets. Valves are not normally used in suction lines, but if a valve is used, install it with the stem horizontal to avoid air pockets.

Strainers

If a strainer is furnished with the pump, be certain to use it; any spherical solids which pass through a strainer furnished with the pump will also pass through the pump itself.

If a strainer is not furnished with the pump, but is installed by the pump user, make certain that the total area of the openings in the strainer is at least three or four times the cross section of the suction line, and that the openings will not permit passage of solids larger than the solids handling capability of the pump.

This pump is designed to handle up to 2 inch (50,8 mm) diameter spherical solids.

Sealing

Since even a slight leak will affect priming, head, and capacity, especially when operating with a high suction lift, all connections in the suction line should be sealed with pipe dope to ensure an air-

tight seal. Follow the sealant manufacturer’s recommendations when selecting and applying the pipe dope. The pipe dope should be compatible with the liquid being pumped.

Suction Lines In Sumps

If a single suction line is installed in a sump, it should be positioned away from the wall of the sump at a distance equal to 1 1/2 times the diameter of the suction line.

If there is a liquid flow from an open pipe into the sump, the flow should be kept away from the suction inlet because the inflow will carry air down into the sump, and air entering the suction line will reduce pump efficiency.

If it is necessary to position inflow close to the suction inlet, install a baffle between the inflow and the suction inlet at a distance 1 1/2 times the diameter of the suction pipe. The baffle will allow entrained air to escape from the liquid before it is drawn into the suction inlet.

If two suction lines are installed in a single sump, the flow paths may interact, reducing the efficiency of one or both pumps. To avoid this, position the suction inlets so that they are separated by a distance equal to at least 3 times the diameter of the suction pipe.

Suction Line Positioning

The depth of submergence of the suction line is critical to efficient pump operation. Figure 2 shows recommended minimum submergence vs. velocity.

NOTE

The pipe submergence required may be reduced by installing a standard pipe increaser fitting at the end of the suction line. The larger opening size will reduce the inlet velocity. Calculate the required submergence using the following formula based on the increased opening size (area or diameter).

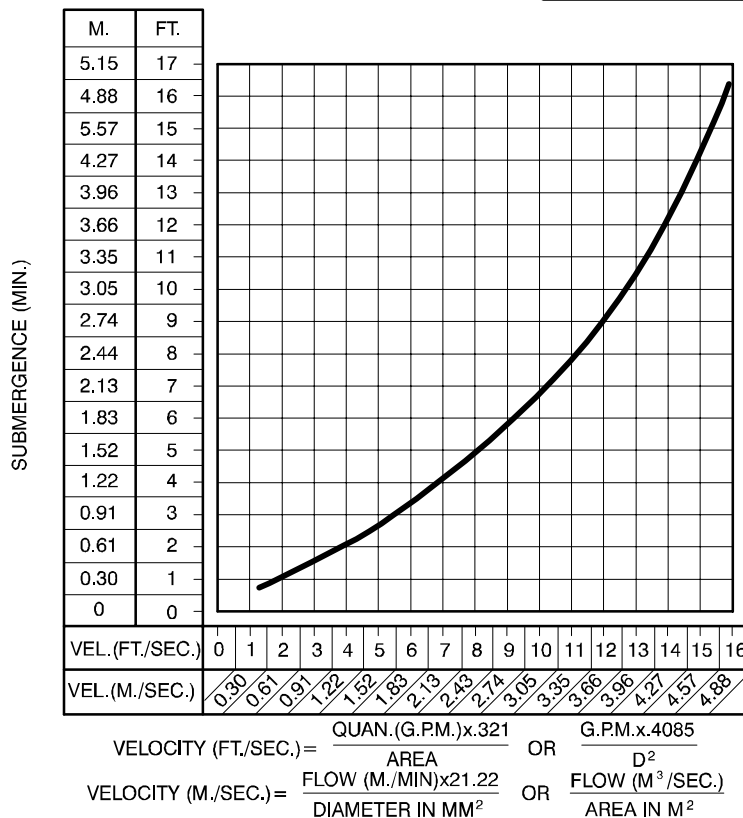

Figure 2. Recommended Minimum Suction Line Submergence vs. Velocity

DISCHARGE LINES

Siphoning

Do not terminate the discharge line at a level lower than that of the liquid being pumped unless a siphon breaker is used in the line. Otherwise, a siphoning action causing damage to the pump could result.

Valves

If a throttling valve is desired in the discharge line, use a valve as large as the largest pipe to minimize friction losses. Never install a throttling valve in a suction line.

With high discharge heads, it is recommended that a throttling valve and a system check valve be installed in the discharge line to protect the pump from excessive shock pressure and reverse rotation when it is stopped.



If the application involves a high discharge head, gradually close the discharge throttling valve before stopping the pump.

Bypass Lines

If a system check valve is used due to high discharge head, it may be necessary to vent trapped air from the top of the pump during the priming process. This may be accomplished by installing a bypass line from the top of the pump, back to the source of liquid. The end of the bypass line must be submerged. The line must be large enough to prevent clogging, but not so large as to affect pump discharge capacity.

ALIGNMENT

The alignment of the pump and engine are critical for trouble-free performance. See Section E, **Securing Intermediate And Drive Assembly To Engine** in **MAINTENANCE AND REPAIR**, for details.

OPERATION – SECTION C

Review all **SAFETY** information in Section A.

Follow the instructions on all tags, labels and decals attached to the pump.



Do not operate an internal combustion engine in an explosive atmosphere. When operating internal combustion engines in an enclosed area, make certain that exhaust fumes are piped to the outside. These fumes contain carbon monoxide, a deadly gas that is colorless, tasteless, and odorless.



This pump is designed to handle most non-volatile, non-flammable liquids containing specified entrained solids. Do not attempt to pump volatile, corrosive, or flammable materials, or any liquids which may damage the pump or endanger personnel as a result of pump failure.



Never tamper with the governor to gain more power. The governor establishes safe operating limits that should not be exceeded. The maximum continuous operating speed for this pump is 2100 RPM.

PRIMING

Install the pump and piping as described in **INSTALLATION**. Make sure that the piping connections are tight, and that the pump is securely mounted. Check that the pump is properly lubri-

cated (see **LUBRICATION** in **MAINTENANCE AND REPAIR**).

This pump is self priming, but the pump should never be operated unless there is liquid in the pump casing.



Never operate this pump unless there is liquid in the pump casing. The pump will not prime when dry. Extended operation of a dry pump will destroy the seal assembly.

Add liquid to the pump casing when:

1. The pump is being put into service for the first time.
2. The pump has not been used for a considerable length of time.
3. The liquid in the pump casing has evaporated.

When installed in a flooded suction application, simply open the system valves and permit the incoming liquid to evacuate the air. After the pump and piping system have completely filled, evacuate any remaining air pockets in the pump or suction line by loosening pipe plug or opening bleeder valves.

Once the pump casing has been filled, the pump will prime and reprime as necessary.



After filling the pump casing, reinstall and tighten the fill plug. Do not attempt to operate the pump unless all connecting piping is securely installed. Otherwise, liquid in the pump forced out under pressure could cause injury to personnel.

To fill the pump, remove the pump casing fill cover or fill plug in the top of the casing, and add clean liquid until the casing is filled. Replace the fill cover or fill plug before operating the pump.

STARTING

If the pump is equipped with the optional automatic starting system, it is subject to automatic restart. Keep hands and clothing away from the unit to prevent injury during automatic operation. Disconnect the positive battery cable before performing any maintenance. Failure to do so may result in serious personal injury.

Consult the operations manual furnished with the engine.

On initial start-up, set the engine speed at the half-throttle position. Turn the keyswitch on the control box to the "START" position until the engine starts. Release the key and the switch will return to the "RUN" position.

After the engine starts and the unit is fully primed, adjust the engine RPM until the desired flow rate is achieved.



Pump speed and operating condition points must be within the continuous performance range shown on the curve on page E-1.

OPERATION

Pump speed and operating condition points must be within the continuous performance range shown on the curve. (See Section E, Page 1.)

Lines With a Bypass

Close the discharge throttling valve (if so equipped) so that the pump will not have to prime against the weight of the liquid in the discharge line. Air from the suction line will be discharged through the bypass line back to the wet well during the priming cycle. When the pump is fully primed and liquid is flowing steadily from the bypass line, open the discharge throttling valve. Liquid will then continue to circulate through the bypass line while the pump is in operation.

Lines Without a Bypass

Open all valves in the discharge line and start the power source. Priming is indicated by a positive reading on the discharge pressure gauge or by a quieter operation. The pump may not prime immediately because the suction line must first fill with liquid. If the pump fails to prime within five minutes, stop it and check the suction line for leaks.

After the pump has been primed, partially close the discharge line throttling valve in order to fill the line slowly and guard against excessive shock pressure which could damage pipe ends, gaskets, sprinkler heads, and any other fixtures connected to the line. When the discharge line is completely filled, adjust the throttling valve to the required flow rate.



Do not operate the pump against a closed discharge throttling valve for long periods of time. If operated against a closed discharge throttling valve, pump components will deteriorate, and the liquid could come to a boil, build pressure, and cause the pump casing to rupture or explode.

Leakage

No leakage should be visible at pump mating surfaces, or at pump connections or fittings. Keep all line connections and fittings tight to maintain maximum pump efficiency.

Liquid Temperature And Overheating

The **maximum** liquid temperature for this pump is 110° F (43°C). Do not apply it at a higher operating temperature.

Overheating can occur if operated with the valves in the suction or discharge lines closed. Operating against closed valves could bring the liquid to a boil, build pressure, and cause the pump to rupture or explode. If overheating occurs, stop the pump and allow it to cool before servicing it. Refill the pump casing with cool liquid.



Allow an over-heated pump to completely cool before servicing. Do not remove plates, covers, gauges, or fittings from an over-heated pump. Liquid within the pump can reach boiling temperatures, and vapor pressure within the pump can cause parts being disengaged to be ejected with great force. After the pump completely cools, drain the liquid from the pump by removing the casing drain plug. Use caution when removing the plug to prevent injury to personnel from hot liquid.

Strainer Check

If a suction strainer has been shipped with the pump or installed by the user, check the strainer regularly, and clean it as necessary. The strainer should also be checked if pump flow rate begins to drop. If a vacuum suction gauge has been installed, monitor and record the readings regularly to detect strainer blockage.

Never introduce air or steam pressure into the pump casing or piping to remove a blockage. This could result in personal injury or damage to the equipment. If backflushing is absolutely necessary, **liquid pressure** must be limited to 50% of the maximum permissible operating pressure shown on the pump performance curve. (See Section E, Page 1.) If the pump is fitted with a Gorman-Rupp double grease lubricated seal, the maximum incoming pressure must be reduced to 10 p.s.i.

Pump Vacuum Check

With the pump inoperative, install a vacuum gauge in the system, using pipe dope on the threads. Block the suction line and start the pump. At operating speed the pump should pull a vacuum of 20 inches (508 mm) or more of mercury. If it does not, check for air leaks in the seal, gasket, or discharge valve.

Open the suction line, and read the vacuum gauge with the pump primed and at operation speed. Shut off the pump. The vacuum gauge reading will immediately drop proportionate to static suction lift, and should then stabilize. If the vacuum reading falls off rapidly after stabilization, an air leak exists. Before checking for the source of the leak, check the point of installation of the vacuum gauge.

STOPPING

Reduce the throttle speed slowly, and allow the engine to idle briefly before switching the HAND-OFF-AUTO switch to 'OFF'.



If the application involves a high discharge head, gradually close the discharge throttling valve before stopping the pump.

After stopping the pump, shut down the engine and disconnect the positive battery cable to ensure that the pump will remain inoperative.

Safety Shutdown System

The unit is equipped with a safety system to automatically shut down the engine under certain conditions. The engine will automatically shut down:

1. If the engine exceeds its safe operating temperature.
2. If the engine oil pressure drops below design limits.
3. If the engine fails to start within a pre-set period of time.
4. If the engine speed exceeds the safe operating range.
5. If the engine V-belt breaks.

Lights on the control panel will indicate which of the safety features has caused the engine to shut down.

Should any of the safety features cause the engine to shut down, **the cause must be determined and corrected** before putting the unit back into service. The engine **will not restart** until the HAND-OFF-AUTO switch has been returned to the 'OFF' position for at least 10 seconds.

All safety shutdown features are pre-set at the factory for optimum performance and safety; **do not** attempt to adjust these settings.



Never disconnect any of the safety shutdown features; this will void the warranty and could result in serious damage to the unit and/or injury to personnel. Safety shutdown features are pre-set at the factory; do not attempt to adjust any of the settings. Determine the cause of shutdown before putting the unit back into service. Consult the factory for additional information.

OPERATION IN EXTREME HEAT

The safety shutdown system will automatically stop the unit if engine operating temperature exceeds design limits. If engine over-temperature shutdown occurs, allow the unit to cool before re-starting.

If engine overheating continues, check the engine lubricant level and viscosity. Consult the engine operation manual for the recommended lubricant for operation in extreme heat.

If the unit is equipped with the optional auto-start control, the float(s) may need to be adjusted to allow shorter run and longer cooling periods, if possible.



If the pump is equipped with the option-

al automatic starting system, it is subject to automatic restart. Keep hands and clothing away from the unit to prevent injury during automatic operation. Disconnect the battery before performing any maintenance. Failure to do so may result in serious personal injury.

BEARING TEMPERATURE CHECK

Bearings normally run at higher than ambient temperatures because of heat generated by friction. Temperatures up to 160°F (71°C) are considered normal for bearings, and they can operate safely to at least 180°F (82°C).

Checking bearing temperatures by hand is inaccurate. Bearing temperatures can be measured accurately by placing a contact-type thermometer against the housing. Record this temperature for future reference.

A sudden increase in bearing temperatures is a warning that the bearings are at the point of failing to operate properly. Make certain that the bearing lubricant is of the proper viscosity and at the correct level (see **LUBRICATION** in Section E). Bearing overheating can also be caused by shaft misalignment and/or excessive vibration.

When pumps are first started, the bearings may seem to run at temperatures above normal. Continued operation should bring the temperatures down to normal levels.

Cold Weather Preservation

In below freezing conditions, drain the pump to prevent damage from freezing. Also, clean out any solids by flushing with a hose. Operate the pump for approximately one minute; this will remove any remaining liquid that could freeze the pump rotating parts. If the pump will be idle for more than a few hours, or if it has been pumping liquids containing a large amount of solids, drain the pump, and flush it thoroughly with clean water. To prevent large solids from clogging the drain port and preventing the pump from completely draining, insert a rod or stiff wire in the drain port, and agitate the liquid during the draining process. Clean out any remaining solids by flushing with a hose.

TROUBLESHOOTING – SECTION D

Review all SAFETY information in Section A.



Before attempting to open or service the pump:

1. Familiarize yourself with this manual.
2. Switch off the engine ignition and disconnect the positive battery

- able to ensure that the pump will remain inoperative.**
3. Allow the pump to completely cool if overheated.
 4. Check the temperature before opening any covers, plates, or plugs.
 5. Close the suction and discharge valves.
 6. Vent the pump slowly and cautiously.
 7. Drain the pump.

TROUBLE	POSSIBLE CAUSE	PROBABLE REMEDY
PUMP FAILS TO PRIME	Not enough liquid in casing. Suction check valve contaminated or damaged. Air leak in suction line. Lining of suction hose collapsed. Leaking or worn seal or pump gasket. Suction lift or discharge head too high. Strainer clogged. Suction check valve or foot valve clogged or binding.	Add liquid to casing. See PRIMING . Clean or replace check valve. Correct leak. Replace suction hose. Check pump vacuum. Replace leaking or worn seal or gasket. Check piping installation and install bypass line if needed. See INSTALLATION . Check strainer and clean if necessary. Clean valve.
PUMP STOPS OR FAILS TO DELIVER RATED FLOW OR PRESSURE	Air leak in suction line. Lining of suction hose collapsed. Leaking or worn seal or pump gasket. Suction intake not submerged at proper level or sump too small.	Correct leak. Replace suction hose. Check pump vacuum. Replace leaking or worn seal or gasket. Check installation and correct submergence as needed.

TROUBLE	POSSIBLE CAUSE	PROBABLE REMEDY
PUMP STOPS OR FAILS TO DELIVER RATED FLOW OR PRESSURE (cont.)	<p>Strainer clogged.</p> <p>Impeller or other wearing parts worn or damaged.</p> <p>Impeller clogged.</p> <p>Suction lift or discharge head too high.</p> <p>Pump speed too slow.</p>	<p>Check strainer and clean if necessary.</p> <p>Replace worn or damaged parts. Check that impeller is properly centered and rotates freely.</p> <p>Free impeller of debris.</p> <p>Check piping installation and install bypass line if needed. See INSTALLATION.</p> <p>Check engine output; consult engine operation manual.</p>
PUMP REQUIRES TOO MUCH POWER	<p>Pump speed too high.</p> <p>Discharge head too low.</p> <p>Liquid solution too thick.</p> <p>Bearing(s) frozen.</p>	<p>Check engine output.</p> <p>Adjust discharge valve.</p> <p>Dilute if possible.</p> <p>Disassemble pump and check bearing(s).</p>
PUMP CLOGS FREQUENTLY	<p>Discharge flow too slow.</p> <p>Suction check valve or foot valve clogged or binding.</p> <p>Discharge line clogged or restricted; hose kinked.</p>	<p>Open discharge valve fully to increase flow rate, and run engine at maximum governed speed.</p> <p>Clean valve.</p> <p>Check discharge lines; straighten hose.</p>
EXCESSIVE NOISE	<p>Cavitation in pump.</p> <p>Pumping entrained air.</p> <p>Pump or drive not securely mounted.</p> <p>Impeller clogged or damaged.</p>	<p>Reduce suction lift and/or friction losses in suction line. Record vacuum and pressure gauge readings and consult local representative or factory.</p> <p>Locate and eliminate source of air bubble.</p> <p>Secure mounting hardware.</p> <p>Clean out debris; replace damaged parts.</p>
BEARINGS RUN TOO HOT	<p>Bearing temperature is high, but within limits.</p> <p>Low or incorrect lubricant.</p> <p>Suction and discharge lines not properly supported.</p> <p>Drive misaligned.</p>	<p>Check bearing temperature regularly to monitor any increase.</p> <p>Check for proper type and level of lubricant.</p> <p>Check piping installation for proper support.</p> <p>Align drive properly.</p>

PREVENTIVE MAINTENANCE

Since pump applications are seldom identical, and pump wear is directly affected by such things as the abrasive qualities, pressure and temperature of the liquid being pumped, this section is intended only to provide general recommendations and practices for preventive maintenance. Regardless of the application however, following a routine preventive maintenance schedule will help assure trouble-free performance and long life from your Gorman-Rupp pump. For specific questions concerning your application, contact your Gorman-Rupp distributor or the Gorman-Rupp Company.

Record keeping is an essential component of a good preventive maintenance program. Changes in suction and discharge gauge readings (if so

equipped) between regularly scheduled inspections can indicate problems that can be corrected before system damage or catastrophic failure occurs. The appearance of wearing parts should also be documented at each inspection for comparison as well. Also, if records indicate that a certain part (such as the seal) fails at approximately the same duty cycle, the part can be checked and replaced before failure occurs, reducing unscheduled down time.

For new applications, a first inspection of wearing parts at 250 hours will give insight into the wear rate for your particular application. Subsequent inspections should be performed at the intervals shown on the chart below. Critical applications should be inspected more frequently.

Preventive Maintenance Schedule					
Item	Service Interval*				
	Daily	Weekly	Monthly	Semi-Annually	Annually
General Condition (Temperature, Unusual Noises or Vibrations, Cracks, Leaks, Loose Hardware, Etc.)	I				
Pump Performance (Gauges, Speed, Flow)	I				
Bearing Lubrication		I			R
Seal Lubrication (And Packing Adjustment, If So Equipped)		I			R
V-Belts (If So Equipped)			I		
Air Release Valve Plunger Rod (If So Equipped)			I	C	
Front Impeller Clearance (Wear Plate)				I	
Rear Impeller Clearance (Seal Plate)				I	
Check Valve					I
Pressure Relief Valve (If So Equipped)					C
Pump and Driver Alignment					I
Shaft Deflection					I
Bearings					I
Bearing Housing					I
Piping					I
Driver Lubrication – See Mfgr’s Literature					I

Legend:
 I = Inspect, Clean, Adjust, Repair or Replace as Necessary
 C = Clean
 R = Replace

* Service interval based on an intermittent duty cycle equal to approximately 4000 hours annually. Adjust schedule as required for lower or higher duty cycles or extreme operating conditions.

PUMP MAINTENANCE AND REPAIR - SECTION E

MAINTENANCE AND REPAIR OF THE WEARING PARTS OF THE PUMP WILL MAINTAIN PEAK OPERATING PERFORMANCE.

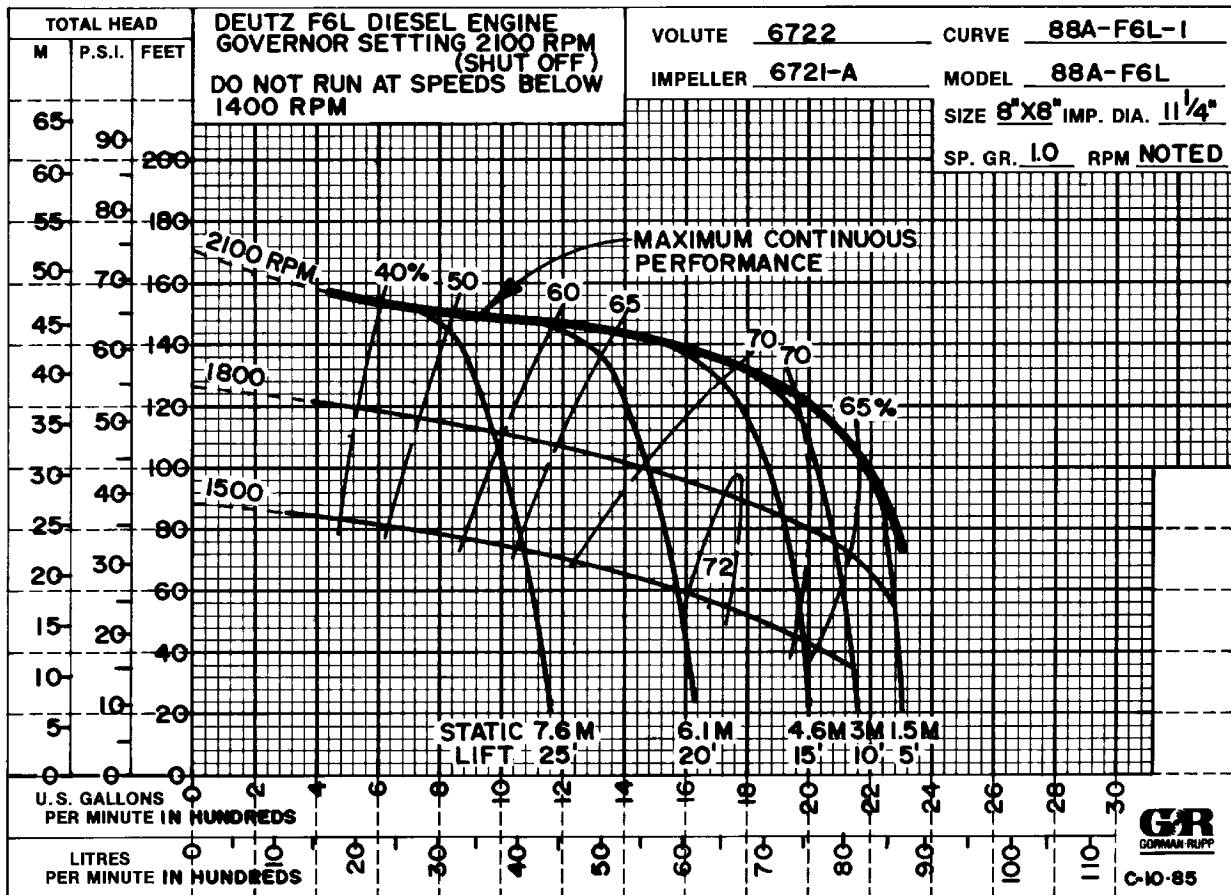

* STANDARD PERFORMANCE FOR PUMP MODEL 88A2-F6L

* Based on 70° F (21° C) clear water at sea level with minimum suction lift. Since pump installations are seldom identical, your performance may be different due to such factors as viscosity, specific gravity, elevation, temperature, and impeller trim.

Contact the Gorman-Rupp Company to verify performance or part numbers.



Pump speed and operating condition points must be within the continuous performance range shown on the curve.

If your pump serial number is followed by an "N", your pump is **NOT** a standard production model.

SECTION DRAWING

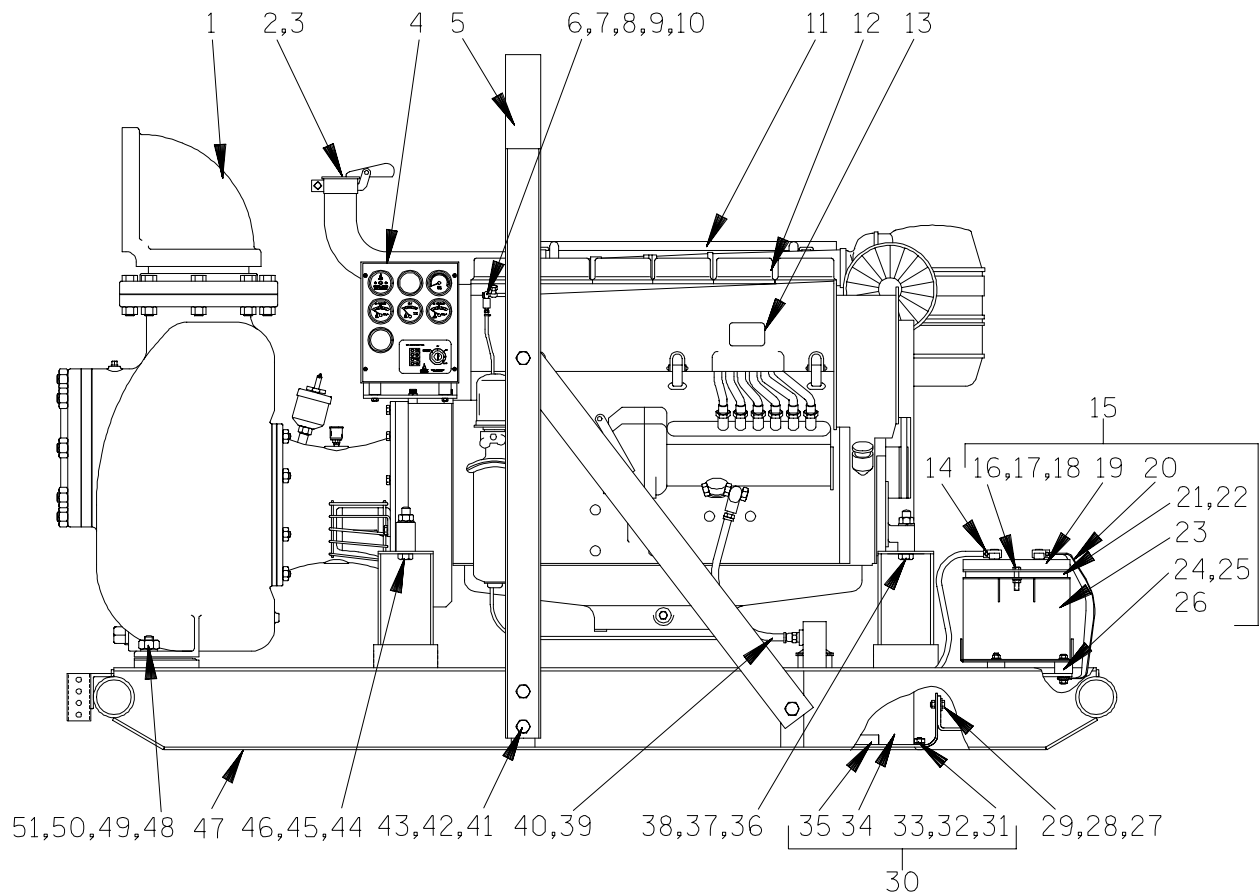

Figure 1. Pump Model 88A2-F6L

PARTS LIST
Pump Model 88A2-F6L
 (From S/N 1306307 up)

If your pump serial number is followed by an "N", your pump is **NOT** a standard production model. Contact the Gorman-Rupp Company to verify part numbers.

ITEM NO.	PART NAME	PART NUMBER	MAT'L CODE	QTY	ITEM NO.	PART NAME	PART NUMBER	MAT'L CODE	QTY
1	PUMP END ASSY	88A2-(SAE 3/10)		1	34	-FUEL TANK ASSY	46711-042	24150	1
2	EXHAUST ELBOW	31912-036	15210	1	35	-FUEL TANK GUARD	34851-178	15080	1
3	WEATHER CAP	S1387	----	1	36	HEX HD CAPSCREW	B0815	15991	2
4	CONTROL PANEL KIT	48122-503	----	1	37	LOCKWASHER	J08	15991	2
5	HOISTING BAIL	13351BB	24000	1	38	HEX NUT	D08	15991	2
6	FUEL RETURN LINE	11308F	----	1	39	HOSE ASSY	46341-803	----	1
7	HOSE CLAMP	26518-641	----	2	40	MALE CONNECTOR	S1447	----	1
8	MALE CONNECTOR	26523-382	----	1	41	HEX HD CAPSCREW	B1006	15991	8
9	REDUCER ELBOW	Q0402	11999	1	42	LOCKWASHER	J10	15991	8
10	FUEL RETURN LINE	14294	24030	1	43	HEX NUT	D10	15991	8
11	MUFFLER GUARD ASSY	42331-035	----	1	44	HEX HD CAPSCREW	B0815	15991	2
12	DEUTZ F6L ENGINE	29217-111	----	1	45	LOCKWASHER	J08	15991	2
13	CAUTION DECAL	2613FJ	----	1	46	HEX NUT	D08	15991	2
14	48" CABLE ASSY	47311-114	----	1	47	COMBINATION BASE	41566-688	24150	1
15	BATTERY BOX ASSY	GRP40-08C	----	1	48	HEX HD CAPSCREW	B1209	15991	2
16	-HEX HD CAPSCREW	B0607	15991	2	49	LOCKWASHER	J12	15991	2
17	-FLAT WASHER	K06	15991	2	50	HEX NUT	D12	15991	2
18	-FLANGED HEX NUT	21765-314	----	2	51	FLAT WASHER	K12	15991	2
19	-BATTERY BX LID ASSY	42113-012	24150	1		NOT SHOWN:			
20	-GROUND CABLE ASSY	47311-064	----	1		WARNING DECAL	2613FE	----	1
21	-12V BATTERY	SEE OPTIONS LIST	REF			ENGINE START UP TAG	38816-269	----	1
22	-BATTERY TAG	38818-506	----	1		OPTIONAL:			
23	-BATTERY BOX ASSY	42431-030	24150	1		* 12V BATTERY	29331-506	----	1
24	-FLANGED HEX NUT	21765-314	----	8		WHEEL KIT	GRP30-248D	----	1
25	-T TYPE LOCKWASHER	BL06	15991	1		REPAIR MUFFLER	42331-050	----	1
26	-STUD MOUNT	24631-006	----	4		GUARD ASSEMBLY			
27	HEX HD CAPSCREW	B0604	15991	10		IMP CLEAN-OUT KIT	48783-006	----	1
28	FLAT WASHER	K06	15991	10		HIGHWAY TRAILERS:			
29	FLANGED HEX NUT	21765-314	----	10		-2" BALL COUPLER	41583-691	----	1
30	FUEL TANK/GRD ASSY	46711-041	----	1		-3" I.D. PINTLE EYE	41583-701	----	1
31	-FLAT WASHER	K06	15991	6					
32	-CARRIAGE BOLT	AB0604	15991	6					
33	-FLANGED HEX NUT	21765-314	----	6					

* INDICATES PARTS RECOMMENDED FOR STOCK

SECTION DRAWING

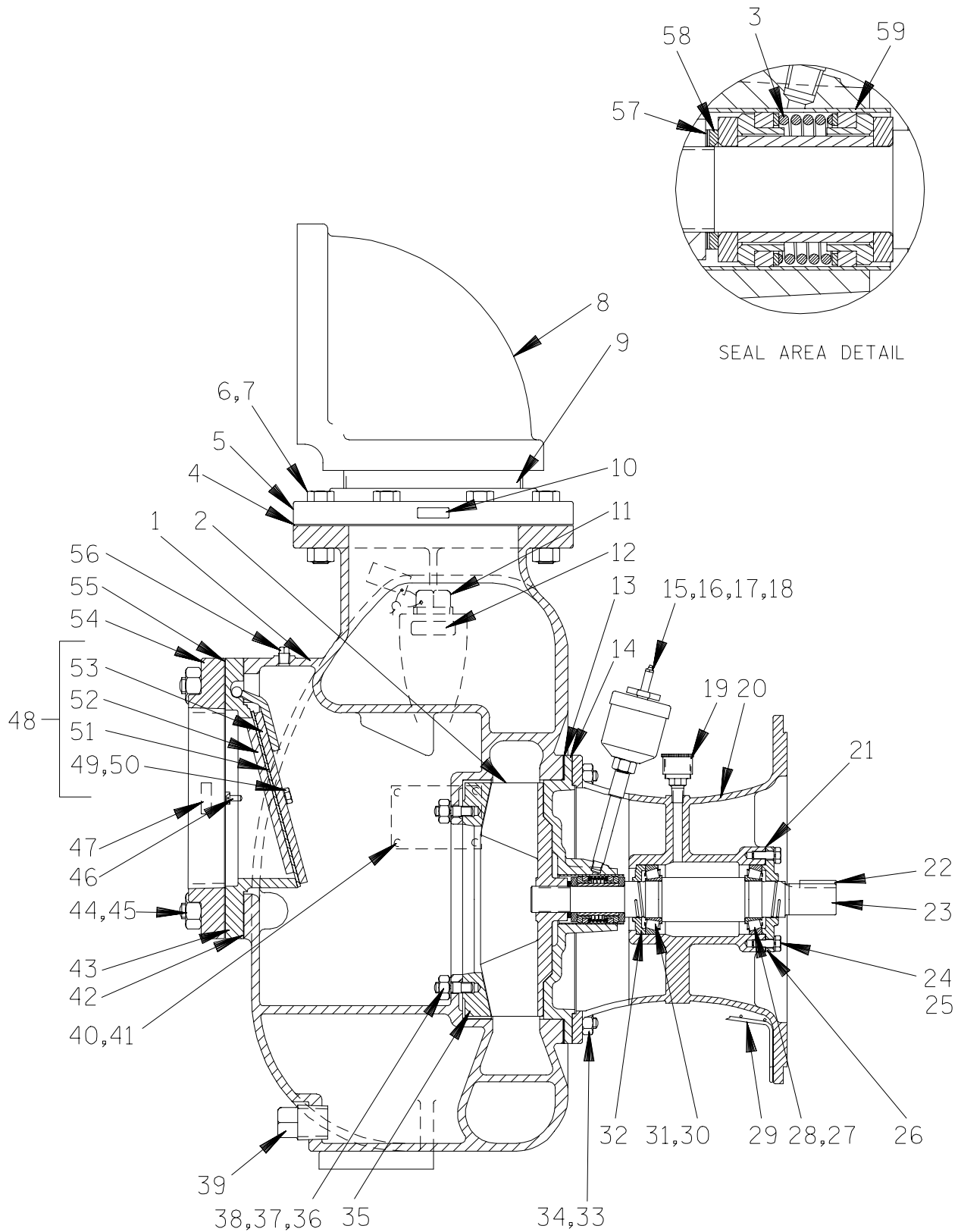

Figure 2. Pump End Assembly 88A2-(SAE 3/10)

PARTS LIST
Pump End Assembly 88A2--(SAE 3/10)

ITEM NO.	PART NAME	PART NUMBER	MAT'L CODE	QTY	ITEM NO.	PART NAME	PART NUMBER	MAT'L CODE	QTY
1	PUMP CASING	6722	10010	1	34	HEX NUT	D08	15991	8
2 *	IMPELLER	6721A	10010	1	35 *	WEAR PLATE	7209A	10010	1
3 *	SEAL ASSEMBLY	GS1250	----	1	36	STUD	C0808	15991	2
4 *	DISCH FLANGE GSKT	1759G	18000	1	37	LOCKWASHER	J08	15991	2
5	DISCHARGE FLANGE	1759	10010	1	38	HEX NUT	D08	15991	2
6	HEX HD CAPSCREW	B1212	15991	8	39	CASING DRAIN PLUG	P20	10009	1
7	HEX NUT	D12	15991	8	40	NAME PLATE	38818-024	13990	1
8	DISCHARGE ELBOW	R0128	10010	1	41	DRIVE SCREW	BM#04-03	17000	4
9	PIPE NIPPLE	T0128	15070	1	42 *	CHCK VLVE SEAT GSKT	7211G	18000	1
10	DISCHARGE STICKER	6588BJ	----	1	43	CHECK VALVE SEAT	7211	10010	1
11	FILL PLUG ASSY	48271-069	----	1	44	STUD	C1215	15991	8
12	PRIMING STICKER	6588AH	----	1	45	HEX NUT	D12	15991	8
13 *	CASING GSKT SET	34G	18000	1	46	RD HD MACH SCREW	X0404	17090	2
14	SEAL PLATE ASSY	2546	10010	1	47	SUCTION STICKER	6588AG	----	1
15	GREASE CUP	S1509	----	1	48	CHECK VALVE ASSY	7214	----	1
16	GREASE CUP INSTR	6588BD	----	1	49	-HEX HD CAPSCREW	B0604	17000	2
17	PIPE COUPLING	AE04	15079	1	50	-LOCKWASHER	J06	17000	2
18	HVY PIPE NIPPLE	THA0416	15079	1	51 *	-CHECK VALVE GSKT	7217	19070	1
19	GREASE CUP	S35	----	1	52	-VALVE WEIGHT	7216	15990	1
20	INTERMEDIATE BRKT	36C	10010	1	53	-VALVE WEIGHT	7215	24000	1
21 *	BEARING SHIM SET	S114	----	1	54	SUCTION FLANGE	1759	10010	1
22 *	IMP SHAFT KEY	N0607	15990	1	55 *	SUCT FLANGE GSKT	1759G	18000	1
23 *	IMP SHAFT	45	15010	1	56	PIPE PLUG	P04	15079	1
24	HEX HD CAPSCREW	B0604	15991	4	57 *	IMP ADJ SHIM SET	37J	17090	REF
25	LOCKWASHER	J06	15991	4	58 *	SEAL WASHER	3349	15990	1
26	BEARING CAP	43X	10010	1	59 *	SEAL LINER	2205	14080	REF
27 *	BEARING CUP	S1086	----	1	NOT SHOWN:				
28 *	BEARING CONE	S1087	----	1		STRAINER	S2279	----	1
29	INTERMEDIATE GUARD	42381-507	24152	2		DRIVE ASSY	44162-119	----	1
30 *	BEARING CUP	S1086	----	1		INSTRUCTION TAG	38817-085	----	1
31 *	BEARING CONE	S1087	----	1		LUBE DECAL	38816-075	----	1
32	BEARING CLOSURE	44	10010	1		WARNING DECAL	2613FE	'----	1
33	STUD	C0809	15991	8		G-R DECAL	GR-06	----	1

* INDICATES PARTS RECOMMENDED FOR STOCK

SECTION DRAWING

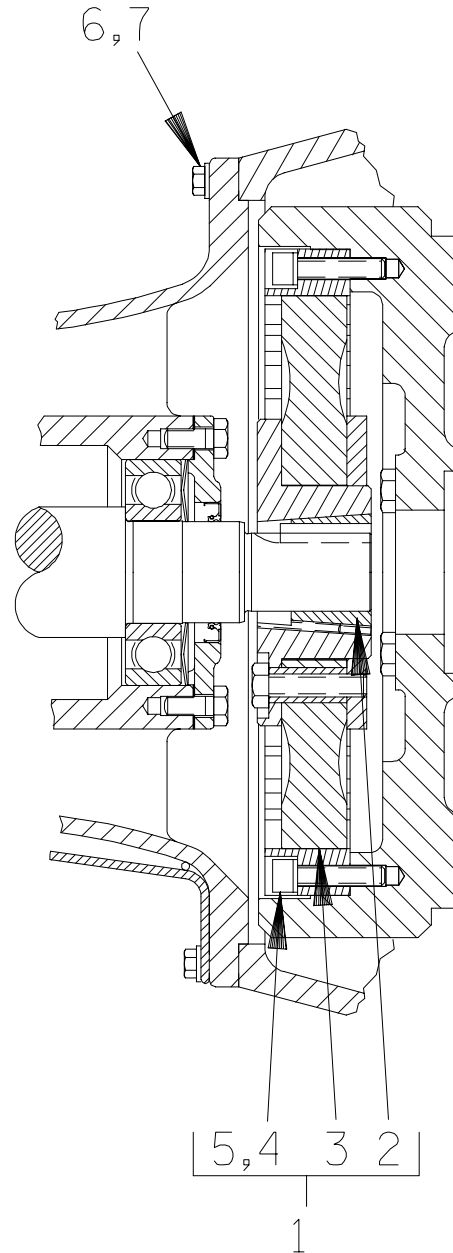

Figure 3. Drive Assembly For Pump End 88A2-(SAE 3/10)

ITEM NO.	PART NAME	PART NUMBER	MAT'L CODE	QTY
1	COUPLING KIT	48112-001	---	1
2	-BUSHING	24131-345	---	1
3	-COUPLING ASSEMBLY	44165-011	---	1
4	-LOCKWASHER	21171-536	---	8
5	-SOCKET HD CAPSCREW	22644-220	---	8
6	HEX HD CAPSCREW	22645-164	---	12
7	LOCKWASHER	21171-511	---	12

PUMP AND SEAL DISASSEMBLY AND REASSEMBLY

Review all SAFETY information in Section A.

Follow the instructions on all tags, label and decals attached to the pump.

This pump requires little service due to its rugged, minimum-maintenance design. However, if it becomes necessary to inspect or replace the wearing parts, follow these instructions which are keyed to the sectional views (see Figures 1, 2 and 3) and the accompanying parts lists.

As described on the following pages, this manual will alert personnel to known procedures which require special attention, to those which could damage equipment, and to those which could be dangerous to personnel. However, this manual cannot possibly anticipate and provide detailed precautions for every situation that might occur during maintenance of the unit. Therefore, it is the responsibility of the owner/maintenance personnel to ensure that **only** safe, established maintenance procedures are used, and that any procedures not addressed in this manual are performed **only** after establishing that neither personal safety nor pump integrity are compromised by such practices.

Before attempting to service the pump, shut down the engine and disconnect the positive battery cable to ensure that the pump will remain inoperative. Close all valves in the suction and discharge lines.

For engine disassembly and repair, consult the literature supplied with the engine, or contact your local engine representative.



Before attempting to open or service the pump:

1. Familiarize yourself with this manual.
2. Shut down the engine and disconnect the positive battery cable to ensure that the pump will remain inoperative.

3. Allow the pump to completely cool if overheated.
4. Check the temperature before opening any covers, plates, or plugs.
5. Close the suction and discharge valves.
6. Vent the pump slowly and cautiously.
7. Drain the pump.

Suction Check Valve Removal

(Figure 2)

Before attempting to service the pump, remove the pump casing drain plug (39) and drain the pump. Clean and reinstall the drain plug.

For access to the check valve, remove the suction piping. Remove the nuts (45) and separate the suction flange and gasket (54 and 55) from the pump casing (1). Replace the suction flange gasket as required.

Disengage the machine screws (46) and pull the check valve seat (43), gasket (42) and check valve assembly (48) from the suction port.

Inspect the check valve parts for wear or damage. If replacement is required, remove the hardware (49 and 50) and separate the check valve gasket (51) and weights (52 and 53).

Separating Pump and Intermediate from Engine

(Figure 3)

If the impeller or seal assembly require replacement, the pump end and drive assembly must be separated from the engine.

Support the pump using a suitable hoist and sling. Remove the hardware (48, 49, 50 and 51, Figure 1) securing the pump casing to the base.



Use lifting and moving equipment in good repair and with adequate capacity to prevent injuries to personnel or damage to equipment. Suction and dis-

charge hoses and piping must be removed from the pump before lifting.

Disengage the hardware (6 and 7) securing the drive assembly to the intermediate. Separate the pump end and drive assembly from the engine by pulling the pump end straight away from the engine.

As the assemblies separate, the flexible portion of the coupling assembly (3) will remain on the shaft. To remove the coupling from the shaft, unscrew the two allen head setscrews from the bushing (2). Screw one of the setscrews into the puller hole on the circumference of the bushing. As the coupling and bushing separate, remove the bushing, and slide the coupling off the shaft. Remove the shaft key (22, Figure 2).

It is not necessary to remove the outer ring of the coupling from the engine flywheel unless the coupling must be replaced. To remove the ring, disengage the hardware (4 and 5) securing it to the flywheel.

Remove any leveling shims used under the casing mounting feet. Tie and tag the shims for ease of reassembly.

Move the pump end to a clean, well equipped shop area for further disassembly.

Loosening Impeller

(Figure 2)

Before loosening the impeller, turn the cross arm on the automatic lubricating grease cup (15) clockwise until it rests against the cover (see Figure 4 in **LUBRICATION**). This will prevent the grease in the cup from escaping when the impeller is removed.

Reach through the suction port and wedge a block of wood between the vanes of the impeller and the pump casing to prevent rotation.

If removed, install the shaft key (22) in the shaft keyway. Install a lathe dog on the drive end of the

shaft (23) with the “V” notch positioned over the shaft key.

With the impeller rotation still blocked, see Figure 4 and use a long piece of heavy bar stock to pry against the arm of the lathe dog in a counterclockwise direction (when facing the drive end of the shaft). **Use caution** not to damage the shaft or keyway. When the impeller breaks loose, remove the lathe dog, key and wood block.

NOTE

Do not remove the impeller until the rotating assembly has been removed from the pump casing.

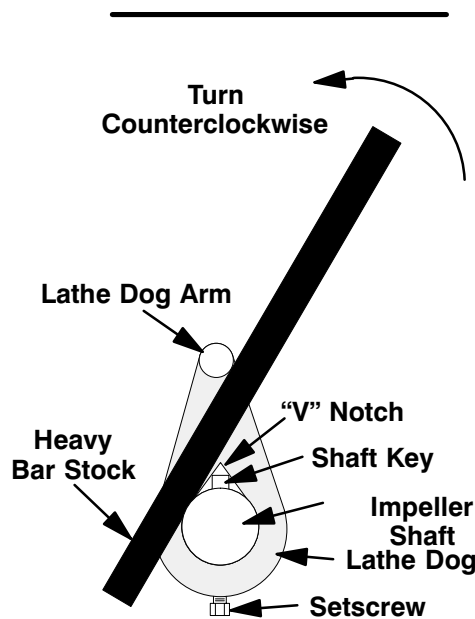

Figure 4. Loosening Impeller

Pump Casing and Wear Plate Removal

(Figure 2)

To service the impeller (2), seal assembly (3) or the seal plate (14), the pump casing must be separated from the intermediate (20). Use the lifting device to position the pump on a suitable work surface with the drive end facing up.

Support the intermediate using a suitable hoist and sling, and disengage the hardware (34) securing the seal plate and intermediate to the pump casing. Use the lifting device to pull the rotating portion of the pump out of the pump casing and remove the gasket set (13). For ease of reassembly, tie and tag the gaskets or measure and record their thickness.

Inspect the wear plate (35) and replace if scored or badly worn. To remove the wear plate, disengage the hardware (37 and 38) from the wear plate studs (36), and pull the wear plate from the pump casing.

Impeller Removal

(Figure 2)

Make certain that the cross arm on the grease cup has been turned down against the cover, then unscrew the impeller from the shaft in a counterclockwise direction (when facing the impeller). Use caution when removing the impeller; tension on the seal spring will be released as the impeller is unscrewed.

Inspect the impeller and replace it if cracked or badly worn. Slide the impeller adjusting shims (57) off the shaft. For ease of reassembly, tie and tag the shims or measure and record their thickness.

Seal Removal

(Figure 2)

For ease of disassembly, the seal and seal plate (14) may be removed as a single unit. Before attempting to remove the seal plate, remove the automatic grease cup and piping (15, 17 and 18).

Slide the seal washer (58) off the shaft. Remove the outer rotating element. Slide the seal plate, spacer sleeve, and remaining seal parts off the shaft as a unit.

Carefully remove the outer stationary seat, rotating element, packing ring, seal washer, and seal spring from the seal plate. Remove the spacer sleeve, inner seal washer, packing ring, stationary seat and rotating element. Use a stiff wire with a hooked end if necessary.

Inspect the seal liner (59) for wear or grooves that could cause leakage or damage to the seal packing rings. The seal liner is secured by a press fit into the seal plate and does not normally require replacement. If replacement is required, see **Seal Installation**.

If no further disassembly is required, refer to **Seal Installation**.

Shaft and Bearing Removal and Disassembly

(Figure 2)

When the pump is properly operated and maintained, the intermediate should not require disassembly. Disassemble the shaft and bearings **only** when there is evidence of wear or damage.

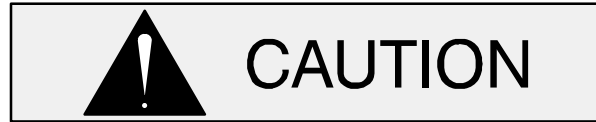

Shaft and bearing disassembly in the field is not recommended. These operations should be performed only in a properly-equipped shop by qualified personnel.

Disengage the hardware (24 and 25), and remove the bearing cap (26) and shims (21). Tie and tag the bearing shims, or measure and record their thickness for ease of reassembly.

Remove the outboard bearing cup (27) from the bearing cone (28).

NOTE

There are no provisions for draining the grease from the intermediate cavity. Place a drip pan under the intermediate before removing the shaft and bearings.

Place a block of wood against the impeller end of the shaft (23), and tap the shaft and assembled bearings from the intermediate. **Be careful** not to damage the shaft.

Use a suitably sized dowel and an arbor (or hydraulic) press to remove the bearing closure (32) and inboard bearing cup (30) from the intermediate.

After removing the shaft and bearings, clean and inspect the bearings **in place** as follows.



To prevent damage during removal from the shaft, it is recommended that bearings be cleaned and inspected **in place**. It is **strongly** recommended that the bearings be replaced **any** time the shaft and bearings are removed.

Clean the intermediate, shaft and all component parts (except the bearings) with a soft cloth soaked in cleaning solvent. Inspect the parts for wear or damage and replace as necessary.



Most cleaning solvents are toxic and flammable. Use them only in a well ventilated area free from excessive heat, sparks, and flame. Read and follow all precautions printed on solvent containers.

Clean the bearings thoroughly in **fresh** cleaning solvent. Dry the bearings with filtered compressed air and coat with light oil.

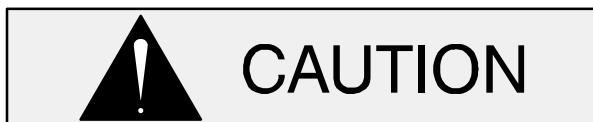

Bearings must be kept free of all dirt and foreign material. Failure to do so will greatly shorten bearing life. **Do not** spin dry bearings. This may scratch the rollers or races, and cause premature bearing failure.

Rotate the bearings by hand to check for roughness or binding and inspect the bearing rollers. If rotation is rough or the rollers are discolored, replace the bearings.

The bearing tolerances provide a tight press fit onto the shaft and a snug slip fit into the bearing housing. Replace the bearing cups or cones, the shaft, or intermediate if the proper bearing fit is not achieved.

If bearing replacement is required, use a bearing puller to remove the inboard and outboard bearing cones (28 and 31) from the shaft.

Shaft and Bearing Reassembly and Installation

(Figure 2)

Clean the intermediate, shaft and all component parts (except the bearings) with a soft cloth soaked in cleaning solvent. Inspect the parts for wear or damage and replace as necessary.



Most cleaning solvents are toxic and flammable. Use them only in a well ventilated area free from excessive heat, sparks, and flame. Read and follow all precautions printed on solvent containers.

Inspect the shaft for distortion, nicks or scratches, or for thread damage on the impeller end. Dress small nicks and burrs with a fine file or emery cloth. Replace the shaft if defective.

Pre-pack the bearings by hand (or use a bearing packer if available) with No. 0 lithium base grease until the bearing rollers are thoroughly lubricated.

Position the inboard and outboard bearing cones (28 and 31) on the impeller shaft (23) with the high side of the tapered roller bearings toward the lubrication cavity. Press the cones onto the shaft until seated squarely against the shaft shoulders.



When installing the bearings onto the shaft, **never** press or hit against the rollers or roll cage. Press **only** on the inner race.

Press the bearing closure (32) and inboard bearing cup (30) into the intermediate until seated squarely against the intermediate shoulder.



When installing the shaft and bearings into the bearing bore, push against the outer race. **Never** hit the rollers or roll cage.

Slide the shaft and assembled bearing cones into the intermediate bore from the drive end until the inboard bearing cone (31) fully engages the inboard bearing cup. Press the outboard bearing cup (27) over the outboard bearing cone (28).

Install the same thickness of bearing adjusting shims (21) as previously removed, and secure them with the bearing cap (26) and hardware (24 and 25).

NOTE

Shaft endplay should be between .003 and .005 inch (0,08 to 0,13mm). Add or remove bearing shims to establish the correct endplay.

Lubricate the bearings as indicated in **LUBRICATION** at the end of this section.

Seal Reassembly and Installation

(Figures 2 and 4)

Clean the seal cavity and shaft with a cloth soaked in fresh cleaning solvent.



Most cleaning solvents are toxic and flammable. Use them only in a well ventilated area free from excessive heat, sparks, and flame. Read and follow all precautions printed on solvent containers.

The seal is not normally reused because wear patterns on the finished faces cannot be realigned during reassembly. This could result in premature

failure. If necessary to reuse an old seal in an emergency, **carefully** wash all metallic parts in **fresh** cleaning solvent and allow to dry thoroughly.

Handle the seal parts with extreme care to prevent damage. Be careful not to contaminate precision finished faces; even fingerprints on the faces can shorten seal life. If necessary, clean the faces with a non-oil based solvent and a clean, lint-free tissue. Wipe **lightly** in a concentric pattern to avoid scratching the faces.

Inspect the seal components for wear, scoring, grooves, and other damage that might cause leakage. Clean and polish the seal spacer sleeve, or replace it if there are nicks or cuts on either end. If any components are worn, replace the complete seal; **never mix old and new seal parts.**

If a replacement seal is being used, remove it from the container and inspect the precision finished faces to ensure that they are free of any foreign matter.

To ease installation of the seal, lubricate the packing rings and seal liner with water or a very **small** amount of oil, and apply a drop of light lubricating oil on the finished faces. Assemble the seal as follows, (see Figure 4).

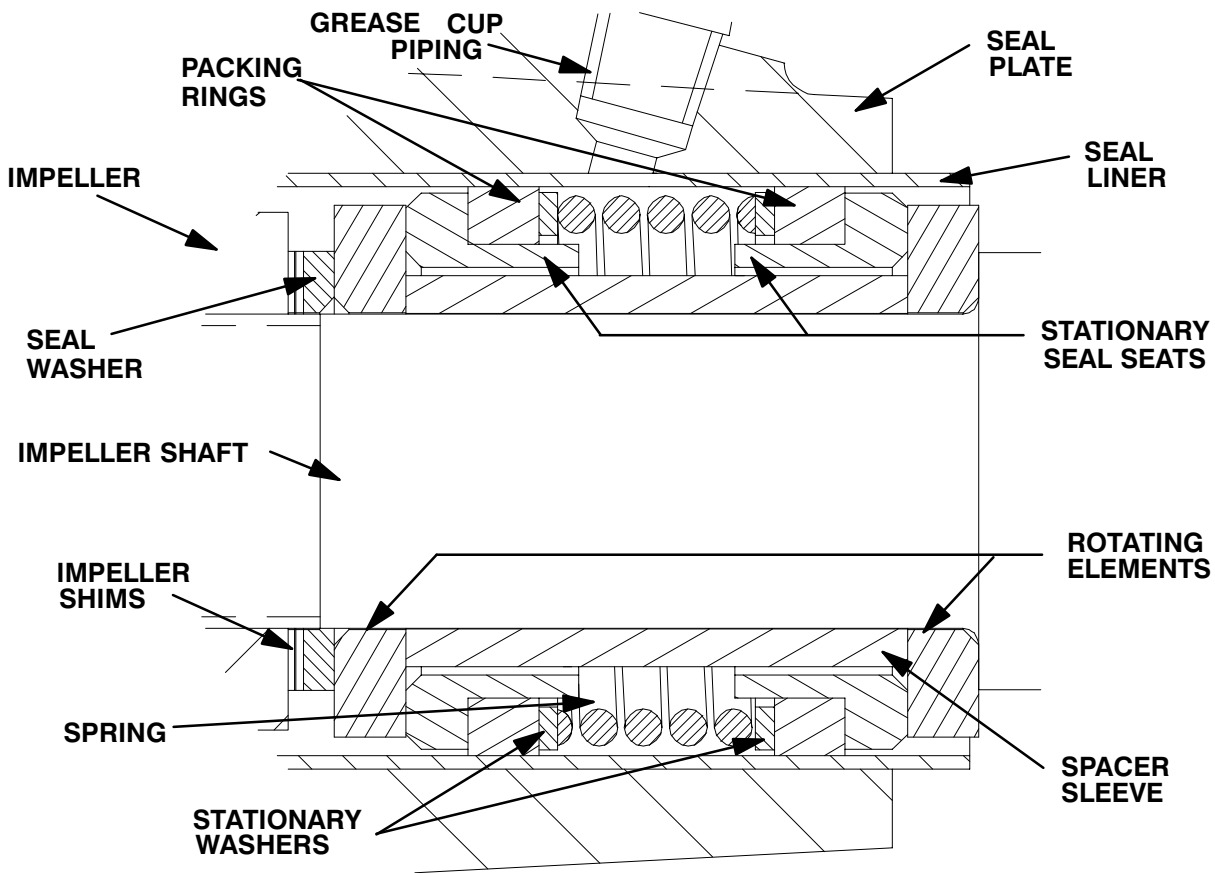

Figure 4. GS1250 Seal Assembly



This seal is not designed for operation at temperatures above 110°F (43°C). Do not use at higher operating temperatures.

Inspect the seal liner (59) and impeller shaft for burrs or sharp corners, and remove any that exist. Replace the seal liner if wear or grooves exist which could cause leakage or damage to the seal packing rings.

To replace the seal liner, position the seal plate (14) on the bed of an arbor (or hydraulic) press and use a new seal liner to press the old liner out. After the new liner is properly installed, a 1/4-inch diameter (6,4 mm) hole must be drilled through it to permit the flow of lubricant to the seal assembly. **Be careful** to center the drill in the threaded hole so not to damage the threads in the pump casing. Deburr the hole from the inside of the seal liner after drilling.

Slide the seal plate onto the shaft until fully seated against the intermediate. Align the threaded seal lubricant hole with the intermediate opening, and temporarily secure the seal plate to the intermediate with two capscrews and nuts (1/2 UNC by 1 1/2 inch long, not supplied).

Position the inboard rotating element on the shaft with the chamfered side facing the spacer washer, and slide it on until fully seated.

Subassemble the inboard stationary seat, packing ring and spring washer. Press this subassembly into the lubricated seal liner. A push tube cut from a length of plastic pipe would aid this installation. The O.D. of the pipe should be approximately the same diameter as the O.D. of the seal spring.

Install the spacer sleeve and spring.

Subassemble the outboard stationary seat, packing ring and spring washer. Press this subassembly into the lubricated seal liner.

Install the outboard rotating element with the chamfered side facing the impeller.

Slide the seal spacer washer (58) onto the shaft with the chamfered side facing the shaft shoulder.

Reinstall the automatic grease cup and piping (15, 17 and 18) in the seal plate. After the impeller has been installed, lubricate the seal as indicated in **LUBRICATION**.

Impeller Installation

(Figure 2)

Inspect the impeller, and replace it if cracked or badly worn. Inspect the impeller and shaft threads for dirt or damage, and clean or dress the threads as required.



The shaft and impeller threads **must** be completely clean before reinstalling the impeller. Even the slightest amount of dirt on the threads can cause the impeller to seize to the shaft, making future removal difficult or impossible without damage to the impeller or shaft.

Install the same thickness of impeller adjusting shims (57) as previously removed. Apply 'Never-Seez' or equivalent to the shaft threads and screw the impeller onto the shaft until tight. Be sure the seal spring seats squarely on the back side of the impeller.

NOTE

*At the slightest sign of binding, immediately back the impeller off, and check the threads for dirt. **Do not** try to force the impeller onto the shaft.*

A clearance of .020 to .040 inch (0,5 to 1,0 mm) between the impeller and the seal plate is recommended for maximum pump efficiency. Measure this clearance and add or subtract impeller shims as required.

NOTE

The seal plate must be tight against the intermedi-

ate while setting the back impeller clearance.

Securing Intermediate And Drive Assembly To Engine

(Figure 3)

Install the shaft key (22, Figure 2) in the shaft keyway. Position the flexible portion of the coupling assembly (3) on the shaft as shown in Figure 3.

NOTE

*The flexible portion of the coupling must be properly positioned on the shaft. The heads of the capscrews in the center of the coupling **must be positioned toward the pump end of the shaft.***

Align the keyway in the bushing (2) with the shaft key, and slide it onto the shaft until it is **just flush** with the end of the shaft. Rotate the flexible portion of the coupling until the tapped holes for the two setscrews align with those in the bushing, and install the setscrews.



Make certain that the flexible portion of the coupling is mounted as shown in Figure 3. **This is critical.** If the coupling is not properly positioned on the shaft, the coupling parts may not fully engage, or a pre-load condition can cause premature bearing failure.

The end of the shaft must be **just flush** with the face of the bushing. This will allow the two portions of the coupling to fully engage when the intermediate is secured to the engine bellhousing, without pre-loading the bearings.

With the flexible portion of the coupling and the bushing properly positioned on the shaft, tighten the two setscrews in an alternating sequence until the bushing and coupling are fully secured. Torque the setscrews to 14.6 ft. lbs. (175 in. lbs. or 2,02 m. kg.).

If the complete coupling assembly is being replaced, apply 'Loctite Retaining Compound No.

242' or equivalent to the threads of the hardware (4 and 5), and secure the outer ring of the coupling to the engine flywheel by torquing the hardware to 45 ft. lbs. (540 in. lbs. or 6,2 m. kg.).

Using a suitable lifting device, position the intermediate (20, Figure 2) so the flexible portion of the coupling seats inside the outer ring attached to the engine flywheel.

NOTE

To ease installation, **lightly** lubricate the rubber portion of the coupling with a **non-petroleum based lubricant** such as vegetable oil or glycerin, or a silicon-based lubricant such as "WD40" or equivalent. **Do not** use petroleum-based lubricants, or any other substance which may soften or otherwise damage the rubber.

Install the intermediate guards (29, Figure 2), and secure the intermediate to the engine bellhousing with the previously removed hardware (6 and 7).

Pump Casing and Wear Plate Installation

(Figure 2)

If the wear plate (35) was removed for replacement, secure the replacement wear plate to the pump casing with the hardware (37 and 38).

Remove the two capscrews temporarily securing the seal plate to the intermediate, and install the same thickness of pump casing gaskets (13) as previously removed. Secure the pump casing to the seal plate and intermediate with the nuts (34).

A clearance of .010 to .020 inch (0,3 to 0,5 mm) between the impeller and the wear plate is also recommended for maximum pump efficiency. This clearance can be obtained by removing gaskets from the casing gasket set until the impeller scrapes against the wear plate when the shaft is turned. After the impeller scrapes, add approximately .010 inch (0,3 mm) of gaskets.

(Figure 1)

Reinstall any leveling shims used under the pump casing mounting feet and secure the casing (1) to the base (48) with the previously removed hardware (49, 50, 51 and 52).

Suction Check Valve Installation

(Figure 2)

Inspect the check valve components and replace them as required. Subassemble the check valve weights (52 and 53) and gasket (51) using the attaching hardware (49 and 50).

Install the check valve assembly in the valve seat (43). Replace the seat gasket (42) and secure the valve seat to the suction port using the round head machine screws (46). Replace the suction flange gasket (55) and secure the suction flange (54) to the seat with the nuts (45).

Check the operation of the check valve to ensure proper seating and free movement.

Final Pump Reassembly

(Figure 1)

Be sure the pump and intermediate are secure to the engine (12) and the base (47).

Install the suction and discharge lines and open all valves. Make certain that all piping connections are tight, properly supported and secure.

Be sure the pump and engine have been properly lubricated, see **LUBRICATION**.

(Figure 2)

Before starting the pump, remove the fill plug assembly (11) and fill the pump casing with clean liquid. Reinstall the fill plug and tighten. (see **OPERATION**, Section C).

LUBRICATION

Seal Assembly

(Figure 2)

Fill the grease cup (15) through the grease fitting with No. 2 lithium base grease until grease escapes from the relief hole. Turn the grease cup arm counterclockwise until it is at the top of the stem; this will release the spring to apply grease to the seal (see Figure 5).

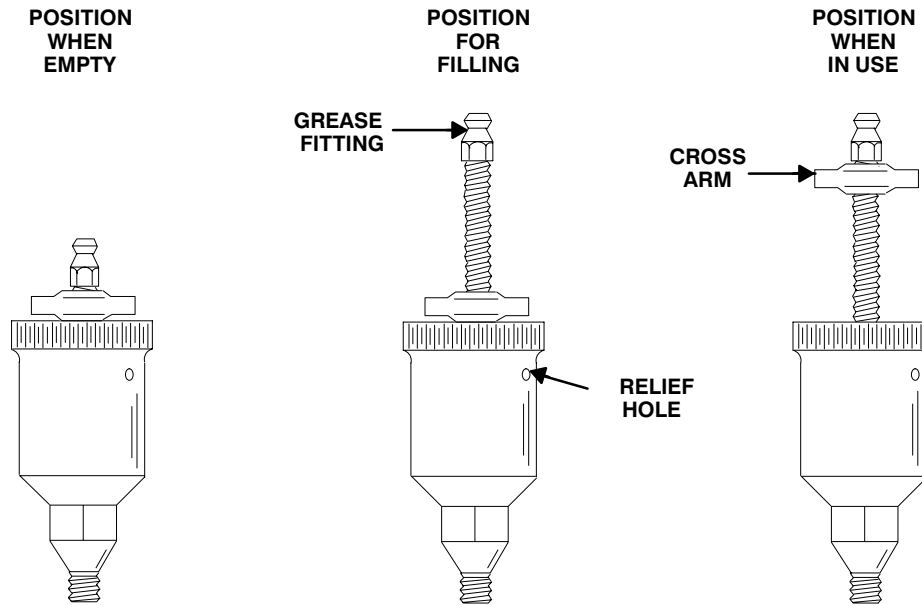

Figure 5. Automatic Lubricating Grease Cup

Bearings

(Figure 2)

The intermediate was fully lubricated when shipped from the factory. Under normal conditions, turn the cap on the grease cup (19) three complete turns to add No. 0 lithium base grease to the intermediate after each 250 hours of operation or once each month, whichever comes first. **Do not** over-lubricate. Over-lubrication can cause the bearings to over-heat, resulting in premature bearing failure.



If grease is forced out around the shaft as new grease is added, the bearing cavity is full and should be disassembled and cleaned immediately.

There are no provisions in the bearing cavity to drain or flush the lubricant. The pump and interme-

diated must be disassembled to completely clean and maintain this cavity.

Under normal conditions, change the grease after each 5000 hours of operation, or at 12 month intervals, whichever comes first. Change the grease more frequently if the pump is operated continuously or installed in an environment where variable hot and cold temperatures are common.

When lubricating a dry (overhauled) intermediate, fill the cavity through the grease cup with approximately one-third of a pound (151 gm) of grease (approximately one-third full).

For cold weather operation, consult the factory or a lubricant supplier for the recommended grade of lubricant.

Engine

Consult the literature supplied with the engine, or contact your local engine representative.

**For U.S. and International Warranty Information,
Please Visit www.grpumps.com/warranty
or call:
U.S.: 419-755-1280
International: +1-419-755-1352**

**For Canadian Warranty Information,
Please Visit www.grcanada.com/warranty
or call:
519-631-2870**