

**INSTALLATION, OPERATION,
AND MAINTENANCE MANUAL**
WITH PARTS LIST



80 SERIES PUMP

MODEL
810A2-F5L

THE GORMAN-RUPP COMPANY • MANSFIELD, OHIO

GORMAN-RUPP OF CANADA LIMITED • ST. THOMAS, ONTARIO, CANADA Printed in U.S.A.

©Copyright by the Gorman-Rupp Company



The engine exhaust from this product contains chemicals known to the State of California to cause cancer, birth defects or other reproductive harm.

TABLE OF CONTENTS

INTRODUCTION	PAGE I – 1
SAFETY - SECTION A	PAGE A – 1
INSTALLATION – SECTION B	PAGE B – 1
Pump Dimensions	PAGE B – 1
PREINSTALLATION INSPECTION	PAGE B – 1
Battery Specifications And Installation	PAGE B – 2
POSITIONING PUMP	PAGE B – 2
Lifting	PAGE B – 2
Mounting	PAGE B – 2
SUCTION AND DISCHARGE PIPING	PAGE B – 3
Materials	PAGE B – 3
Line Configuration	PAGE B – 3
Connections to Pump	PAGE B – 3
Gauges	PAGE B – 3
SUCTION LINES	PAGE B – 3
Fittings	PAGE B – 3
Sealing	PAGE B – 3
Suction Line Positioning	PAGE B – 3
FLOAT SWITCHES	PAGE B – 4
Installation	PAGE B – 4
DISCHARGE LINES	PAGE B – 5
Siphoning	PAGE B – 5
Valves	PAGE B – 5
Bypass Lines	PAGE B – 5
ALIGNMENT	PAGE B – 5
OPERATION – SECTION C	PAGE C – 1
PRIMING	PAGE C – 1
STARTING	PAGE C – 2
Manual Starting	PAGE C – 2
Automatic Starting	PAGE C – 2
OPERATION	PAGE C – 3
Lines With a Bypass	PAGE C – 3
Lines Without a Bypass	PAGE C – 3
Leakage	PAGE C – 3
Liquid Temperature And Overheating	PAGE C – 3
Strainer Check	PAGE C – 3
Pump Vacuum Check	PAGE C – 4
STOPPING	PAGE C – 4
Manual Stopping	PAGE C – 4
Automatic Stopping	PAGE C – 4
Safety Shutdown System	PAGE C – 4
OPERATION IN EXTREME HEAT	PAGE C – 4
BEARING TEMPERATURE CHECK	PAGE C – 5
Cold Weather Preservation	PAGE C – 5

TABLE OF CONTENTS
(continued)

TROUBLESHOOTING – SECTION D	PAGE D – 1
PREVENTIVE MAINTENANCE	PAGE D – 3
PUMP MAINTENANCE AND REPAIR - SECTION E	PAGE E – 1
STANDARD PERFORMANCE CURVE	PAGE E – 1
PARTS LISTS:	
Pump Model	PAGE E – 3
Pump End Assembly	PAGE E – 5
PUMP AND SEAL DISASSEMBLY AND REASSEMBLY	PAGE E – 6
Suction Check Valve Removal	PAGE E – 6
Pump Disassembly	PAGE E – 6
Impeller Removal	PAGE E – 7
Seal Removal	PAGE E – 7
Separating Intermediate And Drive Assembly From Engine	PAGE E – 7
Shaft And Bearing Removal And Disassembly	PAGE E – 8
Shaft and Bearing Reassembly And Installation	PAGE E – 8
Securing Intermediate And Drive Assembly To Engine	PAGE E – 10
Seal Reassembly and Installation	PAGE E – 10
Impeller Installation	PAGE E – 11
Pump Reassembly	PAGE E – 12
Suction Check Valve Installation	PAGE E – 12
Final Pump Reassembly	PAGE E – 12
LUBRICATION	PAGE E – 12
Seal Assembly	PAGE E – 12
Bearings	PAGE E – 13
Engine	PAGE E – 13

INTRODUCTION

This Installation, Operation, and Maintenance manual is designed to help you achieve the best performance and longest life from your Gorman-Rupp pump.

This pump is an 80 Series, semi-open impeller, self-priming centrifugal model with a suction check valve. The pump is designed for handling dirty water containing specified entrained solids. It is powered by an air-cooled Deutz diesel engine, model F5L-912D. The basic material of construction for all wetted parts is gray iron.

If there are any questions regarding the pump or its application which are not covered in this manual or in other literature accompanying this unit, please contact your Gorman-Rupp distributor, or write:

The Gorman-Rupp Company
P.O. Box 1217
Mansfield, Ohio 44901--1217
 or
Gorman-Rupp of Canada Limited
70 Burwell Road
St. Thomas, Ontario N5P 3R7

For information or technical assistance on the engine, contact the engine manufacturer's local dealer or representative.

Because pump installations are seldom identical, this manual cannot possibly provide detailed instructions and precautions for every aspect of each specific application. Therefore, it is the responsibility of the owner/installer of the pump to ensure that applications not addressed in this manual are performed **only** after establishing that neither operator safety nor pump integrity are compromised by the installation. Pumps and related equipment **must** be installed and operated according to all national, local and industry standards.

The following are used to alert maintenance personnel to procedures which require special attention, to those which could damage equipment, and to those which could be dangerous to personnel:



Immediate hazards which WILL result in severe personal injury or death. These instructions describe the procedure required and the injury which will result from failure to follow the procedure.



Hazards or unsafe practices which COULD result in severe personal injury or death. These instructions describe the procedure required and the injury which could result from failure to follow the procedure.



Hazards or unsafe practices which COULD result in minor personal injury or product or property damage. These instructions describe the requirements and the possible damage which could result from failure to follow the procedure.

NOTE

Instructions to aid in installation, operation, and maintenance, or which clarify a procedure.

SAFETY - SECTION A

These warnings apply to 80 Series Engine Driven pumps. Refer to the manual accompanying the engine before attempting to begin operation.

Because pump installations are seldom identical, this manual cannot possibly provide detailed instructions and precautions for each specific application. Therefore, it is the owner/installer's responsibility to ensure that applications not addressed in this manual are performed only after establishing that neither operator safety nor pump integrity are compromised by the installation.



Before attempting to open or service the pump:

1. Familiarize yourself with this manual.
2. Switch off the engine ignition and disconnect the positive battery cable to ensure that the pump will remain inoperative.
3. Allow the pump to completely cool if overheated.
4. Check the temperature before opening any covers, plates, or plugs.
5. Close the suction and discharge valves.
6. Vent the pump slowly and cautiously.
7. Drain the pump.



If the pump is equipped with the optional automatic starting system, it is subject to automatic restart. Keep hands

and clothing away from the unit to prevent injury during automatic operation. Disconnect the positive battery cable before performing any maintenance. Failure to do so may result in serious personal injury.



This pump is designed to handle dirty water containing specified entrained solids. Do not attempt to pump volatile, corrosive, or flammable liquids which may damage the pump or endanger personnel as a result of pump failure.



Use lifting and moving equipment in good repair and with adequate capacity to prevent injuries to personnel or damage to equipment. Suction and discharge hoses and piping must be removed from the pump before lifting.



After the pump has been installed, make certain that the pump and all piping or hose connections are tight, properly supported and secure before operation.



Do not operate the pump against a closed discharge valve for long periods of time. If operated against a closed discharge valve, pump components will deteriorate, and the liquid could come to a boil, build pressure, and cause the pump casing to rupture or explode.

**WARNING!**

Do not remove plates, covers, gauges, pipe plugs, or fittings from an overheated pump. Vapor pressure within the pump can cause parts being disengaged to be ejected with great force. Allow the pump to completely cool before servicing.

**DANGER!**

Do not operate an internal combustion engine in an explosive atmosphere. When operating internal combustion engines in an enclosed area, make certain that exhaust fumes are piped to the outside. These fumes contain carbon monoxide, a deadly gas that is colorless, tasteless, and odorless.

**WARNING!**

Fuel used by internal combustion engines presents an extreme explosion and fire hazard. Make certain that all fuel lines are securely connected and free of leaks. Never refuel a hot or running engine. Avoid overfilling the fuel tank. Always use the correct type of fuel.

**WARNING!**

Never tamper with the governor to gain more power. The governor establishes safe operating limits that should not be exceeded. The maximum continuous operating speed for this pump is 1980 RPM.

INSTALLATION – SECTION B

Review all **SAFETY** information in Section A.

Since pump installations are seldom identical, this section offers only general recommendations and practices required to inspect, position, and arrange the pump and piping.

Most of the information pertains to a standard **static lift** application where the pump is positioned above the free level of liquid to be pumped.

If installed in a **flooded suction application** where the liquid is supplied to the pump under pressure, some of the information such as mounting, line configuration, and priming must be tailored to the specific application. Since the pressure supplied

to the pump is critical to performance and safety, **be sure** to limit the incoming pressure to 50% of the maximum permissible operating pressure as shown on the pump performance curve. (See Section E, Page 1.) If the pump is fitted with a Gorman-Rupp double grease lubricated seal, the maximum incoming pressure must be reduced to 10 p.s.i.

For further assistance, contact your Gorman-Rupp distributor or the Gorman-Rupp Company.

Pump Dimensions

See Figure 1 for the approximate physical dimensions of this pump.

OUTLINE DRAWING

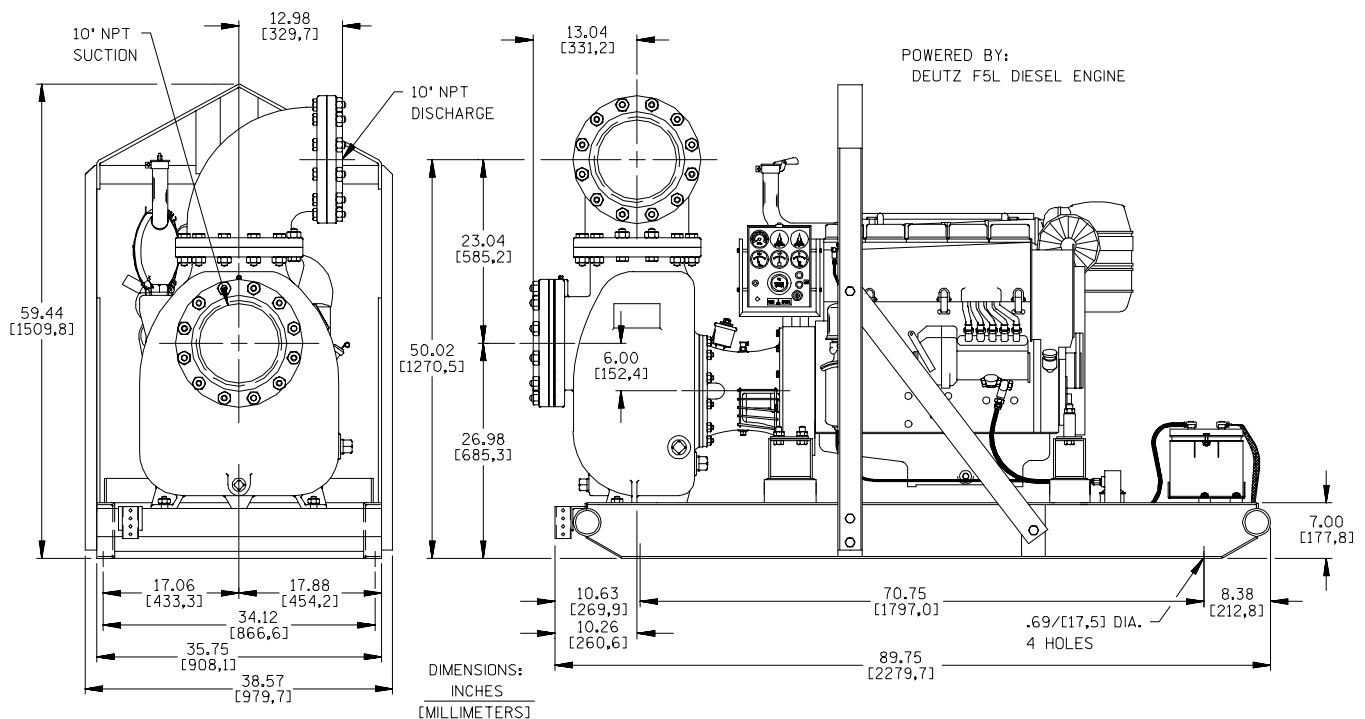

Figure 1. Pump Model 810A2–F5L

PREINSTALLATION INSPECTION

The pump assembly was inspected and tested before shipment from the factory. Before installation, inspect the pump for damage which may have occurred during shipment. Check as follows:

- Inspect the pump and engine for cracks, dents, damaged threads, and other obvious damage.
- Check for and tighten loose attaching hardware. Since gaskets tend to shrink after dry-

ing, check for loose hardware at mating surfaces.

- c. Carefully read all tags, decals, and markings on the pump assembly, and perform all duties indicated.
- d. Check levels and lubricate as necessary. Refer to **LUBRICATION** in the **MAINTENANCE AND REPAIR** section of this manual and perform duties as instructed.
- e. If the pump and engine have been stored for more than 12 months, some of the components or lubricants may have exceeded their maximum shelf life. These **must be inspected or replaced** to ensure maximum pump service.

If the maximum shelf life has been exceeded, or if anything appears to be abnormal, contact your Gorman-Rupp distributor or the factory to determine the repair or updating policy. **Do not** put the pump into service until appropriate action has been taken.

Battery Specifications And Installation

Unless otherwise specified on the pump order, the engine battery was **not** included with the unit. Refer to the following specifications when selecting a battery.

Table 1. Battery Specifications

Voltage	Cold Crank Amps @ 0° F	Reserve Capacity @ 80° F (Minutes)	Amp/ Hr. Rating	Approx. Overall Dims. (Inches)
12 Volts	960-975	365	175	20.5L x 8.75W x 9.75H

Refer to the information accompanying the battery and/or electrolyte solution for activation and charging instructions.

Before installing the battery, clean the positive and negative cable connectors, and the battery terminals. Secure the battery by tightening the holddown brackets. The terminals and clamps may be coated with petroleum jelly to retard corrosion. Connect and tighten the positive cable first, then the negative cable.

POSITIONING PUMP



Use lifting and moving equipment in good repair and with adequate capacity to prevent injuries to personnel or damage to equipment. Suction and discharge hoses and piping must be removed from the pump before lifting.

Lifting

Use lifting equipment with a capacity of at least **14,500 pounds (6577 kg)**. This pump weighs approximately **2890 pounds (1311 kg)**, not including the weight of accessories and optional wheel kit. Customer installed equipment such as suction and discharge piping **must** be removed before attempting to lift.



The pump assembly can be seriously damaged if the cables or chains used to lift and move the unit are improperly wrapped around the pump.

Mounting

Locate the pump in an accessible place as close as practical to the liquid being pumped. Level mounting is essential for proper operation.

The pump may have to be supported or shimmed to provide for level operation or to eliminate vibration.

If the pump has been mounted on a moveable base, make certain the base is stationary by setting the brake and blocking the wheels before attempting to operate the pump.

To ensure sufficient lubrication and fuel supply to the engine, **do not** position the pump and engine more than 15° off horizontal for continuous operation. The pump and engine may be positioned up to 30° off horizontal for **intermittent operation**

only; however, the engine manufacturer should be consulted for continuous operation at angles greater than 15°.

SUCTION AND DISCHARGE PIPING

Materials

Either pipe or hose may be used for suction and discharge lines; however, the materials must be compatible with the liquid being pumped. If hose is used in suction lines, it must be the rigid-wall, reinforced type to prevent collapse under suction. Using piping couplings in suction lines is not recommended.

Line Configuration

Keep suction and discharge lines as straight as possible to minimize friction losses. Make minimum use of elbows and fittings, which substantially increase friction loss. If elbows are necessary, use the long-radius type to minimize friction loss.

Connections to Pump

Before tightening a connecting flange, align it exactly with the pump port. Never pull a pipe line into place by tightening the flange bolts and/or couplings.

Lines near the pump must be independently supported to avoid strain on the pump which could cause excessive vibration, decreased bearing life, and increased shaft and seal wear. If hose-type lines are used, they should have adequate support to secure them when filled with liquid and under pressure.

Gauges

Most pumps are drilled and tapped for installing discharge pressure and vacuum suction gauges. If these gauges are desired for pumps that are not tapped, drill and tap the suction and discharge lines not less than 18 inches (457,20 mm) from the suction and discharge ports and install the lines. Installation closer to the pump may result in erratic readings.

SUCTION LINES

To avoid air pockets which could affect pump priming, the suction line must be as short and direct as possible. When operation involves a suction lift, the line must always slope upward to the pump from the source of the liquid being pumped; if the line slopes down to the pump at any point along the suction run, air pockets will be created.

Fittings

Suction lines should be the same size as the pump inlet. If reducers are used in suction lines, they should be the eccentric type, and should be installed with the flat part of the reducers uppermost to avoid creating air pockets. Valves are not normally used in suction lines, but if a valve is used, install it with the stem horizontal to avoid air pockets.

This pump is designed to handle up to 2 1/2 inch (63,5 mm) diameter spherical solids.

Sealing

Since even a slight leak will affect priming, head, and capacity, especially when operating with a high suction lift, all connections in the suction line should be sealed with pipe dope to ensure an airtight seal. Follow the sealant manufacturer's recommendations when selecting and applying the pipe dope. The pipe dope should be compatible with the liquid being pumped.

Suction Line Positioning

The depth of submergence of the suction line is critical to efficient pump operation. Figure 2 shows recommended minimum submergence vs. velocity.

NOTE

The pipe submergence required may be reduced by installing a standard pipe increaser fitting at the end of the suction line. The larger opening size will reduce the inlet velocity. Calculate the required submergence using the following formula based on the increased opening size (area or diameter).

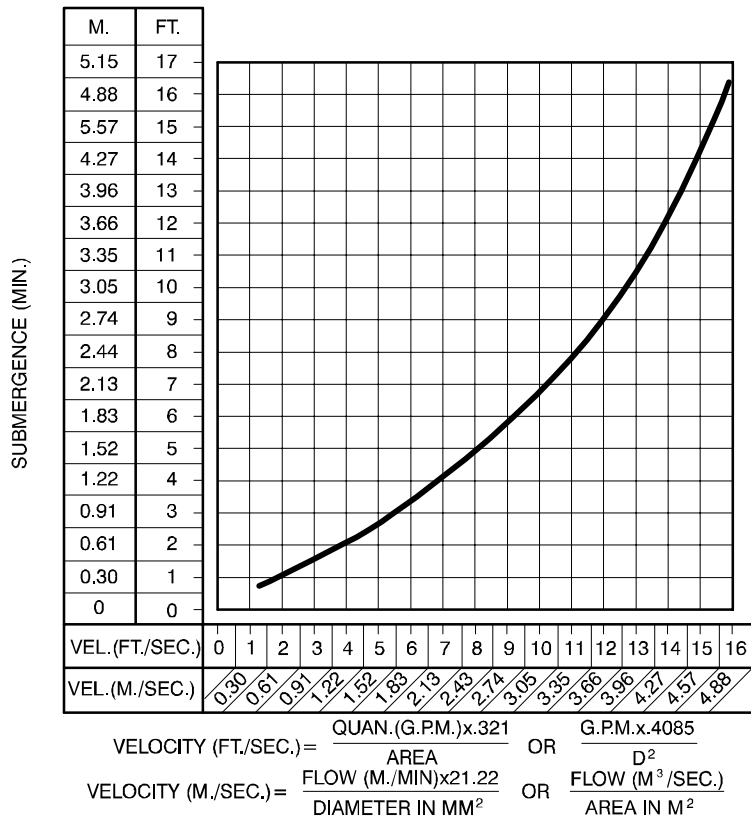

Figure 2. Recommended Minimum Suction Line Submergence vs. Velocity

FLOAT SWITCHES

Installation

The standard pump is **not** furnished with a means to automatically regulate liquid level. However, if the unit is equipped with the optional auto-start control system, the pump can be conformed to start and stop as the liquid level in the wet well or sump rises and falls. The autostart option employs either a single or double float switch system, where a bulb raises or lowers (floats) with the liquid level, thus activating an enclosed miniature switch. The floats are equipped with a socket type connector that plugs into a matching receptacle on the auto-start control box.

Standard floats are equipped with 50 feet (15,2 m) of cable.

When installing the floats, note the following:

- a. **Be sure** to provide sufficient room in the wet well or sump so that floats do not get obstructed or drawn into the suction line. If a flexible suction hose is used, it may be extended to lay along the bottom of the wet well or sump

and the float can be attached to the hose above the point where it bends along the bottom. Direct the suction line toward the flow, and the float(s) away from the flow. If a standpipe is available, attach the float switch cable to the standpipe in the sump at the approximate desired liquid level.

- b. In a single float system, the cable can be tethered to the suction line or standpipe approximately 6 inches (152 mm) above the float. This setting allows approximately 9 inches (229 mm) of liquid rise between pump start/stop. The start/stop interval may be increased by extending the float end of the cable. The liquid level in the sump will increase approximately 8 inches (203 mm) between start/stop intervals for every 6 inches (152 mm) of cable increase.
- c. If a double float switch system is used, position the "Start" float at the desired high water level in the sump, and the "Stop" float at the desired low water level in the pump.
- d. Refer to Figure 3 for additional float switch data.

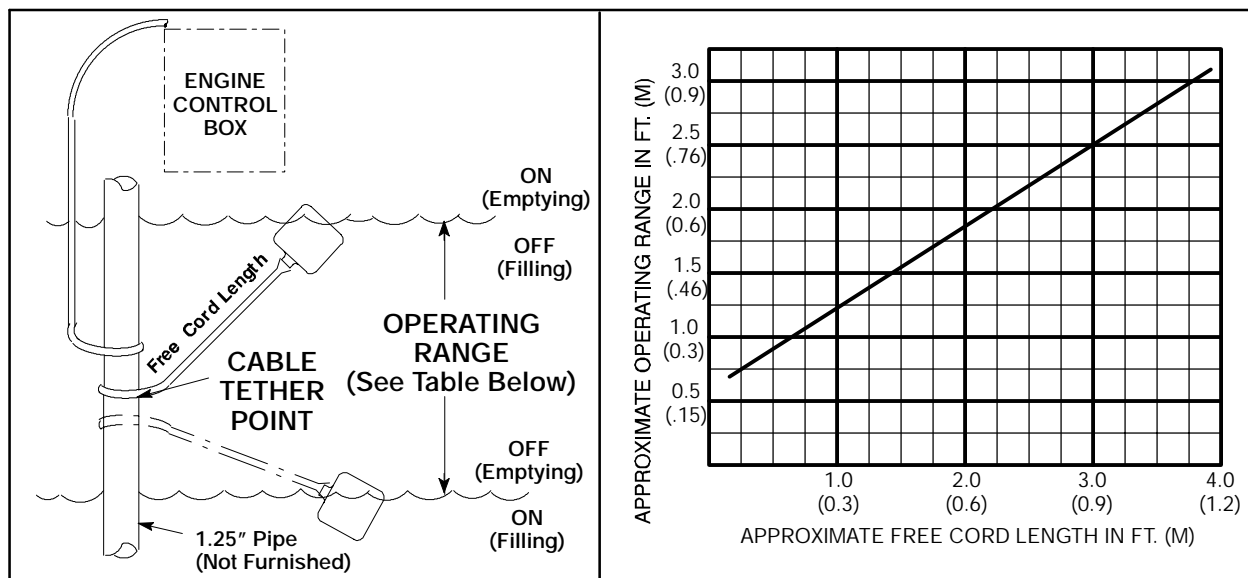

Figure 3. Float Switch Data

DISCHARGE LINES

Siphoning

Do not terminate the discharge line at a level lower than that of the liquid being pumped unless a siphon breaker is used in the line. Otherwise, a siphoning action causing damage to the pump could result.

Valves

If a throttling valve is desired in the discharge line, use a valve as large as the largest pipe to minimize friction losses. Never install a throttling valve in a suction line.

With high discharge heads, it is recommended that a throttling valve and a system check valve be installed in the discharge line to protect the pump from excessive shock pressure and reverse rotation when it is stopped.



If the application involves a high discharge head, gradually close the discharge throttling valve before stopping the pump.

Bypass Lines

If a system check valve is used due to high discharge head, it may be necessary to vent trapped air from the top of the pump during the priming process. This may be accomplished by installing a bypass line from the top of the pump, back to the source of liquid. The end of the bypass line must be submerged. The line must be large enough to prevent clogging, but not so large as to affect pump discharge capacity.

ALIGNMENT

The alignment of the pump and the engine is critical for trouble-free mechanical operation. See Section E, **Securing Intermediate And Drive Assembly To Engine** for detailed information.

OPERATION – SECTION C

Review all SAFETY information in Section A.

Follow the instructions on all tags, labels and decals attached to the pump.



Do not operate an internal combustion engine in an explosive atmosphere. When operating internal combustion engines in an enclosed area, make certain that exhaust fumes are piped to the outside. These fumes contain carbon monoxide, a deadly gas that is colorless, tasteless, and odorless.



This pump is designed to handle dirty water containing specified entrained solids. Do not attempt to pump volatile, corrosive, or flammable liquids which may damage the pump or endanger personnel as a result of pump failure.



Never tamper with the governor to gain more power. The governor establishes safe operating limits that should not be exceeded. The maximum continuous operating speed for this pump is 1980 RPM.

PRIMING

Install the pump and piping as described in **INSTALLATION**. Make sure that the piping connections are tight, and that the pump is securely mounted. Check that the pump is properly lubricated (see **LUBRICATION** in **MAINTENANCE AND REPAIR**).

This pump is self priming, but the pump should never be operated unless there is liquid in the pump casing.



Never operate this pump unless there is liquid in the pump casing. The pump will not prime when dry. Extended operation of a dry pump will destroy the seal assembly.

Add liquid to the pump casing when:

1. The pump is being put into service for the first time.
2. The pump has not been used for a considerable length of time.
3. The liquid in the pump casing has evaporated.

When installed in a flooded suction application, simply open the system valves and permit the incoming liquid to evacuate the air. After the pump and piping system have completely filled, evacuate any remaining air pockets in the pump or suction line by loosening pipe plug or opening bleeder valves.

Once the pump casing has been filled, the pump will prime and reprime as necessary.



After filling the pump casing, reinstall and tighten the fill plug. Do not attempt to operate the pump unless all connecting piping is securely installed. Otherwise, liquid in the pump forced out under pressure could cause injury to personnel.

To fill the pump, remove the pump casing fill cover or fill plug in the top of the casing, and add clean liquid until the casing is filled. Replace the fill cover or fill plug before operating the pump.

STARTING



If the pump is equipped with the optional automatic starting system, it is subject to automatic restart. Keep hands and clothing away from the unit to prevent injury during automatic operation. Disconnect the positive battery cable before performing any maintenance. Failure to do so may result in serious personal injury.

Consult the operations manual furnished with the engine.

Manual Starting

On initial start-up, set the engine speed at the half-throttle position. Turn the keyswitch on the control box to the "START" position until the engine starts. Release the key and the switch will return to the "RUN" position.

After the engine starts and the unit is fully primed, adjust the engine RPM until the desired flow rate is achieved.



Pump speed and operating condition points must be within the continuous performance range shown on the curve on page E-1.

Automatic Starting

If the unit is equipped with the optional autostart control system, install the float(s) as described in **INSTALLATION, Section B**.

Follow the procedures outlined for manual starting and throttle adjustment, then turn the key to the "AUTO START" position.

NOTE

For security purposes, the key can be removed with

the switch in the "AUTO START" position.

Press and hold the white "AUTO" button on the control panel until the red "AUTO" light illuminates. The auto-start system is now armed.

NOTE

The unit can continue to be started manually with the keyswitch in the "AUTO START" position by pressing the white "MAN" button on the control. The "Single Lightning Bolt" light on the control will illuminate in conjunction with an audible alarm before the unit starts. The unit can then be stopped manually by pressing the "OFF/SET" button.

In the auto-start mode, the "Single Lightning Bolt" light will illuminate in conjunction with an audible alarm when the liquid level in the sump or wet well rises and activates the float(s). The light will blink and the alarm will sound for approximately 8 seconds before the unit starts.

When the liquid level in the sump or wet well is sufficiently pumped down, the unit will automatically shut down.

NOTE

If the keyswitch is moved to the "OFF" position while in the auto-start mode, the engine will stop. However, the auto-start process will continue as soon as the keyswitch is moved back to the "AUTO START" position. To cancel the auto-start process, press the "OFF/SET" button.

The control panel is equipped with high oil temperature, low oil pressure, V-belt and start failure (3 attempts) safety shutdowns. If any of these problems occur, the red "Double Lightning Bolt" light will illuminate to indicate a system fault. When the problem is corrected, press the "OFF/SET" button to re-set the control.

NOTE

The "OFF/SET" button has dual functionality when in program mode. If necessary, consult the factory for details on programming functions.

The unit can be started manually with the keyswitch in the "AUTO START" position by pressing

the white "MAN" button. The "Single Lightning Bolt" light will illuminate in conjunction with an audible alarm before the unit starts.

Stop the unit manually by pressing the "OFF/SET" button.

OPERATION

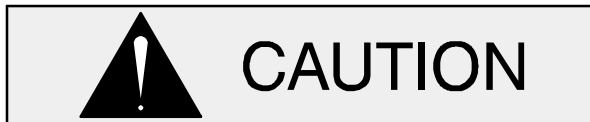

Pump speed and operating condition points must be within the continuous performance range shown on the curve. (See Section E, Page 1.)

Lines With a Bypass

Close the discharge throttling valve (if so equipped) so that the pump will not have to prime against the weight of the liquid in the discharge line. Air from the suction line will be discharged through the bypass line back to the wet well during the priming cycle. When the pump is fully primed and liquid is flowing steadily from the bypass line, open the discharge throttling valve. Liquid will then continue to circulate through the bypass line while the pump is in operation.

Lines Without a Bypass

Open all valves in the discharge line and start the power source. Priming is indicated by a positive reading on the discharge pressure gauge or by a quieter operation. The pump may not prime immediately because the suction line must first fill with liquid. If the pump fails to prime within five minutes, stop it and check the suction line for leaks.

After the pump has been primed, partially close the discharge line throttling valve in order to fill the line slowly and guard against excessive shock pressure which could damage pipe ends, gaskets, sprinkler heads, and any other fixtures connected to the line. When the discharge line is completely filled, adjust the throttling valve to the required flow rate.

Leakage

No leakage should be visible at pump mating surfaces, or at pump connections or fittings. Keep all line connections and fittings tight to maintain maximum pump efficiency.

Liquid Temperature And Overheating

The **maximum** liquid temperature for this pump is 110° F (43°C). Do not apply it at a higher operating temperature.

Overheating can occur if operated with the valves in the suction or discharge lines closed. Operating against closed valves could bring the liquid to a boil, build pressure, and cause the pump to rupture or explode. If overheating occurs, stop the pump and allow it to cool before servicing it. Refill the pump casing with cool liquid.



Do not remove plates, covers, gauges, pipe plugs, or fittings from an overheated pump. Vapor pressure within the pump can cause parts being disengaged to be ejected with great force. Allow the pump to cool before servicing.

Strainer Check

If a suction strainer has been shipped with the pump or installed by the user, check the strainer regularly, and clean it as necessary. The strainer should also be checked if pump flow rate begins to drop. If a vacuum suction gauge has been installed, monitor and record the readings regularly to detect strainer blockage.

Never introduce air or steam pressure into the pump casing or piping to remove a blockage. This could result in personal injury or damage to the equipment. If backflushing is absolutely necessary, **liquid pressure** must be limited to 50% of the maximum permissible operating pressure shown on the pump performance curve. (See Section E, Page 1.) If the pump is fitted with a Gorman-Rupp double grease lubricated seal, the maximum incoming pressure must be reduced to 10 p.s.i.

Pump Vacuum Check

With the pump inoperative, install a vacuum gauge in the system, using pipe dope on the threads. Block the suction line and start the pump. At operating speed the pump should pull a vacuum of 20 inches (508 mm) or more of mercury. If it does not, check for air leaks in the seal, gasket, or discharge valve.

Open the suction line, and read the vacuum gauge with the pump primed and at operation speed. Shut off the pump. The vacuum gauge reading will immediately drop proportionate to static suction lift, and should then stabilize. If the vacuum reading falls off rapidly after stabilization, an air leak exists. Before checking for the source of the leak, check the point of installation of the vacuum gauge.

STOPPING

Manual Stopping

In the manual mode, reduce the throttle speed slowly, and allow the engine to idle briefly before switching the HAND-OFF-AUTO switch to 'OFF'.



If the application involves a high discharge head, gradually close the discharge throttling valve before stopping the pump.

After stopping the pump, switch off the engine ignition and disconnect the positive battery cable to ensure that the pump will remain inoperative.

Automatic Stopping

In the automatic mode, the pump will stop when the liquid in the wet well or sump lowers and activates the "Off" float switch(s). The pump will restart automatically when the liquid rises and activates the "On" float switch(s).

Safety Shutdown System

The unit is equipped with a safety system to automatically shut down the engine under certain conditions. The engine will automatically shut down:

1. If the engine exceeds its safe operating temperature.
2. If the engine oil pressure drops below design limits.
3. If the engine fails to start within a pre-set period of time.
4. If the engine speed exceeds the safe operating range.
5. If the engine fan belt breaks.

Lights on the control panel will indicate which of the safety features has caused the engine to shut down.

Should any of the safety features cause the engine to shut down, **the cause must be determined and corrected** before putting the unit back into service. The engine **will not restart** until the HAND-OFF-AUTO switch has been returned to the 'OFF' position for at least 10 seconds.

All safety shutdown features are pre-set at the factory for optimum performance and safety; **do not** attempt to adjust these settings.



Never disconnect any of the safety shutdown features; this will void the warranty and could result in serious damage to the unit and/or injury to personnel. Safety shutdown features are pre-set at the factory; do not attempt to adjust any of the settings. Determine the cause of shutdown before putting the unit back into service. Consult the factory for additional information.

OPERATION IN EXTREME HEAT

The safety shutdown system will automatically stop the unit if engine operating temperature exceeds design limits. If engine over-temperature shutdown occurs, allow the unit to cool before re-starting.

If engine overheating continues, check the engine lubricant level and viscosity. Consult the engine

operation manual for the recommended lubricant for operation in extreme heat.

If the unit is equipped with the optional auto-start control, the float(s) may need to be adjusted to allow shorter run and longer cooling periods, if possible.



If the pump is equipped with the optional automatic starting system, it is subject to automatic restart. Keep hands and clothing away from the unit to prevent injury during automatic operation. Disconnect the battery before performing any maintenance. Failure to do so may result in serious personal injury.

BEARING TEMPERATURE CHECK

Bearings normally run at higher than ambient temperatures because of heat generated by friction. Temperatures up to 160°F (71°C) are considered normal for bearings, and they can operate safely to at least 180°F (82°C).

Checking bearing temperatures by hand is inaccurate. Bearing temperatures can be measured accurately by placing a contact-type thermometer

against the housing. Record this temperature for future reference.

A sudden increase in bearing temperatures is a warning that the bearings are at the point of failing to operate properly. Make certain that the bearing lubricant is of the proper viscosity and at the correct level (see **LUBRICATION** in Section E). Bearing overheating can also be caused by shaft misalignment and/or excessive vibration.

When pumps are first started, the bearings may seem to run at temperatures above normal. Continued operation should bring the temperatures down to normal levels.

Cold Weather Preservation

In below freezing conditions, drain the pump to prevent damage from freezing. Also, clean out any solids by flushing with a hose. Operate the pump for approximately one minute; this will remove any remaining liquid that could freeze the pump rotating parts. If the pump will be idle for more than a few hours, or if it has been pumping liquids containing a large amount of solids, drain the pump, and flush it thoroughly with clean water. To prevent large solids from clogging the drain port and preventing the pump from completely draining, insert a rod or stiff wire in the drain port, and agitate the liquid during the draining process. Clean out any remaining solids by flushing with a hose.

TROUBLESHOOTING – SECTION D

Review all SAFETY information in Section A.



Before attempting to open or service the pump:

1. Familiarize yourself with this manual.
2. Switch off engine ignition and disconnect the positive battery cable to ensure that the pump will remain inoperative.
3. Allow the pump to completely cool if overheated.
4. Check the temperature before opening any covers, plates, or plugs.

5. Close the suction and discharge valves.
6. Vent the pump slowly and cautiously.
7. Drain the pump.



If the pump is equipped with the optional automatic starting system, it is subject to automatic restart. Keep hands and clothing away from the unit to prevent injury during automatic operation. Disconnect the positive battery cable before performing any maintenance. Failure to do so may result in serious personal injury.

Table 1. Trouble Shooting Chart

TROUBLE	POSSIBLE CAUSE	PROBABLE REMEDY
PUMP FAILS TO PRIME	Not enough liquid in casing.	Add liquid to casing. See PRIMING .
	Suction check valve contaminated or damaged.	Clean or replace check valve.
	Air leak in suction line.	Correct leak.
	Lining of suction hose collapsed.	Replace suction hose.
	Leaking or worn seal or pump gasket.	Check pump vacuum. Replace leaking or worn seal or gasket.
	Suction lift or discharge head too high.	Check piping installation and install bypass line if needed. See INSTALLATION .
	Strainer clogged.	Check strainer and clean if necessary.
PUMP STOPS OR FAILS TO DELIVER RATED FLOW OR PRESSURE	Suction check valve or foot valve clogged or binding.	Repair priming device or check installation.
	Air leak in suction line.	Correct leak.
	Lining of suction hose collapsed.	Replace suction hose.

Table 1. Trouble Shooting Chart (cont.)

TROUBLE	POSSIBLE CAUSE	PROBABLE REMEDY
PUMP STOPS OR FAILS TO DELIVER RATED FLOW OR PRESSURE (cont.)	<p>Leaking or worn seal or pump gasket.</p> <p>Suction intake not submerged at proper level or sump too small.</p> <p>Strainer clogged.</p> <p>Impeller or other wearing parts worn or damaged.</p> <p>Impeller clogged.</p> <p>Suction lift too high.</p> <p>Pump speed too slow.</p>	<p>Check pump vacuum. Replace leaking or worn seal or gasket.</p> <p>Check installation and correct submergence as needed.</p> <p>Check strainer and clean if necessary.</p> <p>Replace worn or damaged parts. Check that impeller is properly centered and rotates freely.</p> <p>Free impeller of debris.</p> <p>Measure lift w/vacuum gauge. Reduce lift and/or friction losses in suction line.</p> <p>Check engine output; consult engine operation manual.</p>
PUMP REQUIRES TOO MUCH POWER	<p>Pump speed too high.</p> <p>Discharge head too low.</p> <p>Liquid solution too thick.</p> <p>Bearing(s) frozen.</p>	<p>Check engine output.</p> <p>Adjust discharge valve.</p> <p>Dilute if possible.</p> <p>Disassemble pump and check bearing(s).</p>
PUMP CLOGS FREQUENTLY	<p>Discharge flow too slow.</p> <p>Suction check valve or foot valve clogged or binding.</p> <p>Discharge line clogged or restricted; hose kinked.</p>	<p>Open discharge valve fully to increase flow rate, and run engine at maximum governed speed.</p> <p>Clean valve.</p> <p>Check discharge lines; straighten hose.</p>
EXCESSIVE NOISE	<p>Cavitation in pump.</p> <p>Pumping entrained air.</p> <p>Pump or drive not securely mounted.</p> <p>Impeller clogged or damaged.</p>	<p>Reduce suction lift and/or friction losses in suction line. Record vacuum and pressure gauge readings and consult local representative or factory.</p> <p>Locate and eliminate source of air bubble.</p> <p>Secure mounting hardware.</p> <p>Clean out debris; replace damaged parts.</p>

Table 1. Trouble Shooting Chart (cont.)

TROUBLE	POSSIBLE CAUSE	PROBABLE REMEDY
BEARINGS RUN TOO HOT	Bearing temperature is high, but within limits. Low or incorrect lubricant. Suction and discharge lines not properly supported. Drive misaligned.	Check bearing temperature regularly to monitor any increase. Check for proper type and level of lubricant. Check piping installation for proper support. Align drive properly.

PREVENTIVE MAINTENANCE

Since pump applications are seldom identical, and pump wear is directly affected by such things as the abrasive qualities, pressure and temperature of the liquid being pumped, this section is intended only to provide general recommendations and practices for preventive maintenance. Regardless of the application however, following a routine preventive maintenance schedule will help assure trouble-free performance and long life from your Gorman-Rupp pump. For specific questions concerning your application, contact your Gorman-Rupp distributor or the Gorman-Rupp Company.

Record keeping is an essential component of a good preventive maintenance program. Changes in suction and discharge gauge readings (if so

equipped) between regularly scheduled inspections can indicate problems that can be corrected before system damage or catastrophic failure occurs. The appearance of wearing parts should also be documented at each inspection for comparison as well. Also, if records indicate that a certain part (such as the seal) fails at approximately the same duty cycle, the part can be checked and replaced before failure occurs, reducing unscheduled down time.

For new applications, a first inspection of wearing parts at 250 hours will give insight into the wear rate for your particular application. Subsequent inspections should be performed at the intervals shown on the chart below. Critical applications should be inspected more frequently.

Preventive Maintenance Schedule					
Item	Service Interval*				
	Daily	Weekly	Monthly	Semi-Annually	Annually
General Condition (Temperature, Unusual Noises or Vibrations, Cracks, Leaks, Loose Hardware, Etc.)	I				
Pump Performance (Gauges, Speed, Flow)	I				
Bearing Lubrication		I			R
Seal Lubrication (And Packing Adjustment, If So Equipped)		I			R
V-Belts (If So Equipped)			I		
Air Release Valve Plunger Rod (If So Equipped)			I	C	
Front Impeller Clearance (Wear Plate)				I	
Rear Impeller Clearance (Seal Plate)				I	
Check Valve					I
Pressure Relief Valve (If So Equipped)					C
Pump and Driver Alignment					I
Shaft Deflection					I
Bearings					I
Bearing Housing					I
Piping					I
Driver Lubrication – See Mfgr’s Literature					I
<p>Legend: I = Inspect, Clean, Adjust, Repair or Replace as Necessary C = Clean R = Replace</p> <p>* Service interval based on an intermittent duty cycle equal to approximately 4000 hours annually. Adjust schedule as required for lower or higher duty cycles or extreme operating conditions.</p>					

PUMP MAINTENANCE AND REPAIR - SECTION E

MAINTENANCE AND REPAIR OF THE WEARING PARTS OF THE PUMP WILL MAINTAIN PEAK OPERATING PERFORMANCE.

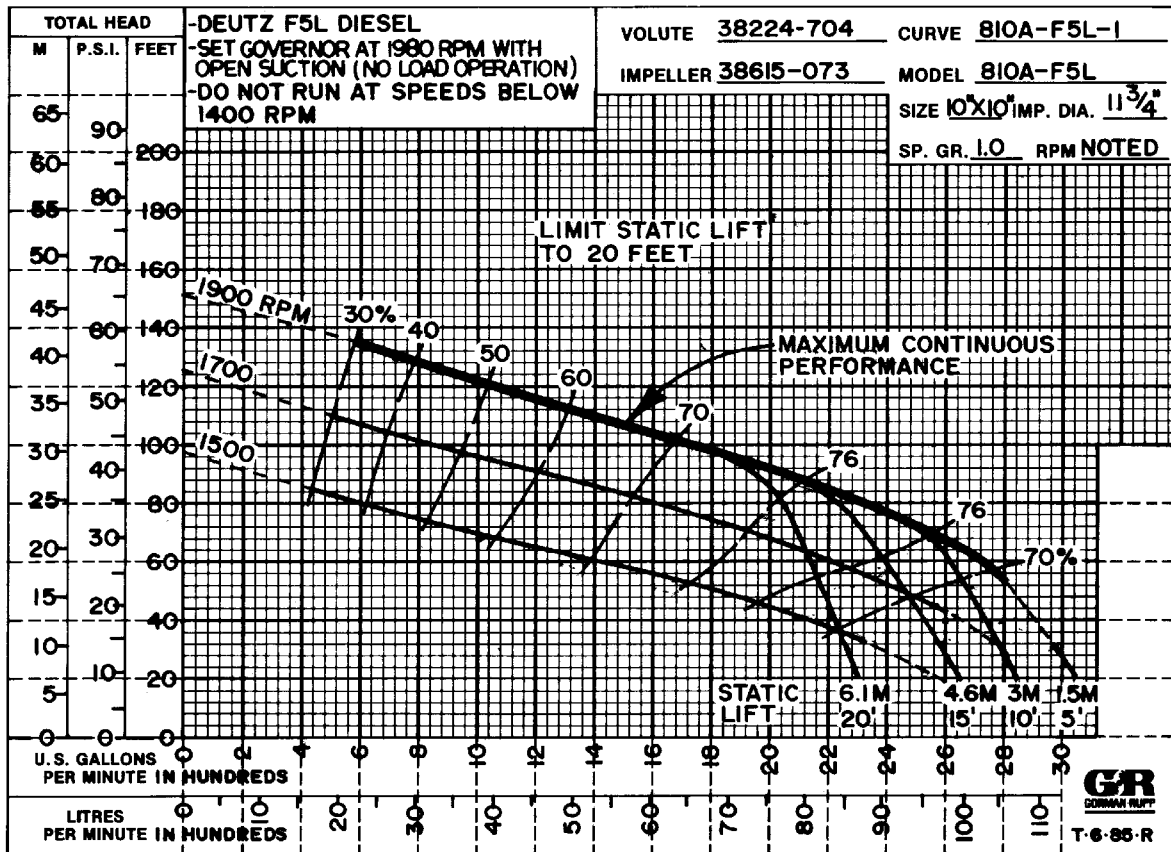

* STANDARD PERFORMANCE FOR PUMP MODEL 810A2--F5L

* Based on 70° F (21° C) clear water at sea level with minimum suction lift. Since pump installations are seldom identical, your performance may be different due to such factors as viscosity, specific gravity, elevation, temperature, and impeller trim.

Contact the Gorman-Rupp Company to verify performance or part numbers.



CAUTION

If your pump serial number is followed by an "N", your pump is **NOT** a standard production model.

Pump speed and operating condition points must be within the continuous performance range shown on the curve.

SECTION DRAWING

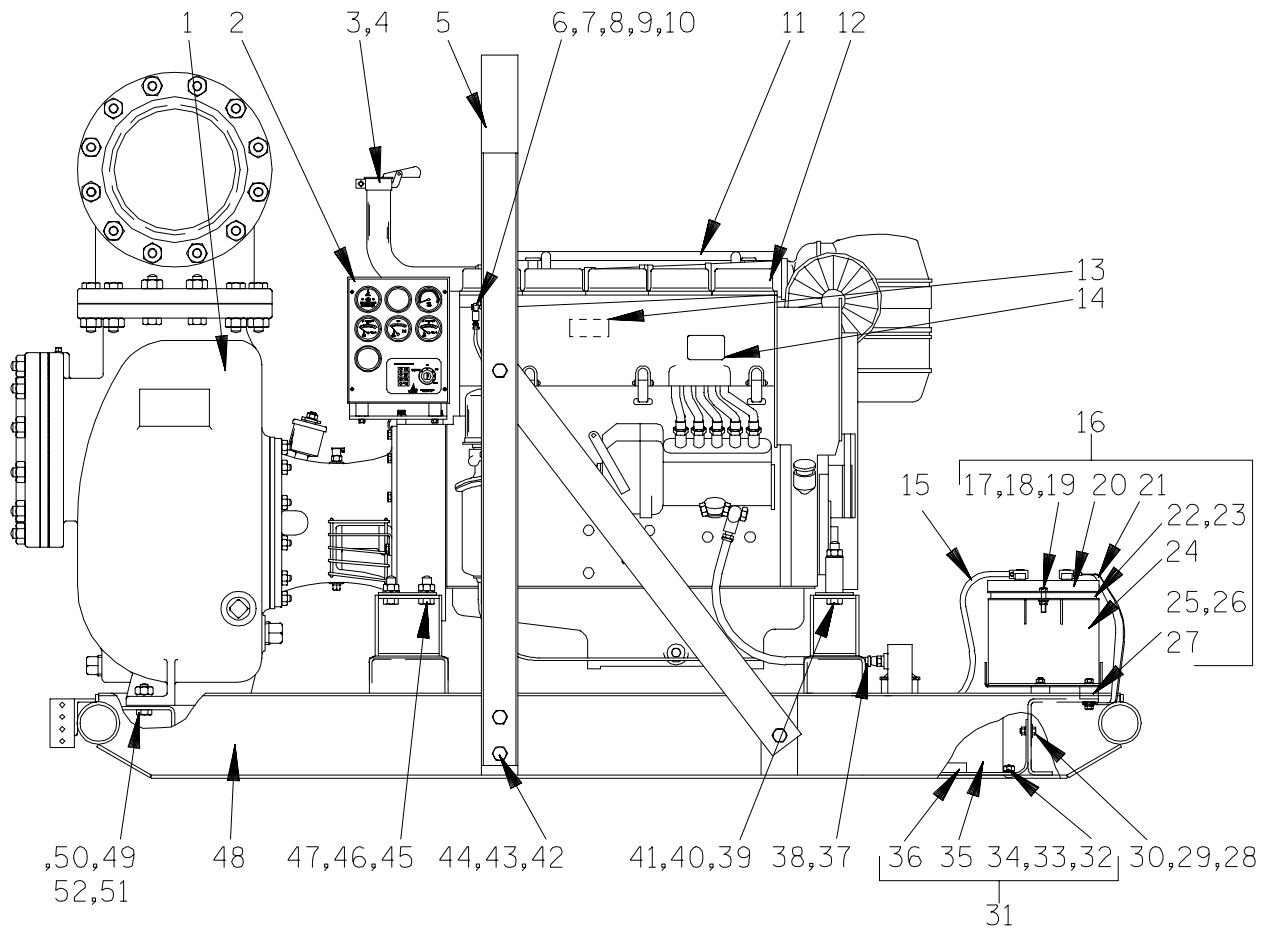

Figure 1. Pump Model 810A2-F5L

PARTS LIST
Pump Model 810A2–F5L
 (From S/N 1279234 up)

If your pump serial number is followed by an "N", your pump is **NOT** a standard production model. Contact the Gorman-Rupp Company to verify part numbers.

ITEM NO.	PART NAME	PART NUMBER	MAT'L CODE	QTY	ITEM NO.	PART NAME	PART NUMBER	MAT'L CODE	QTY
1	PUMP END ASSY	810A2–(F5L)	---	1	31	FUEL TANK ASSY	46711–041	---	1
2	CONTROL PANEL	48122–501	---	1	32	–FLAT WASHER	K06	15991	6
3	EXHAUST ELBOW	31912–024	15990	1	33	–CARRIAGE BOLT	AB0604	15991	6
4	WEATHER CAP	S1246	---	1	34	–FLANGED HEX NUT	21765–314	---	6
5	HOISTING BAIL	13351BB	24000	1	35	–FUEL TANK	46711–042	---	1
6	FUEL RETURN LINE	11308F	---	1	36	–TANK GUARD ASSY	34851–178	15080	1
7	HOSE CLAMP	26518–641	---	2	37	HOSE INLET ASSY	46341–796	---	1
8	MALE CONNECTOR	26523–382	---	1	38	MALE CONNECTOR	S1447	---	1
9	REDUCER ELBOW	Q0402	11999	1	39	HEX HD CAPSCREW	B1017	15991	2
10	FUEL RETURN LINE	14294	24030	1	40	LOCKWASHER	J10	15991	2
11	REPAIR MUFFLER GRD	42331–049	---	1	41	HEX NUT	D10	15991	2
12	DEUTZ F5L ENGINE	29217–061	---	1	42	HEX HD CAPSCREW	B1006	15991	8
13	WARNING DECAL	2613FE	---	1	43	LOCKWASHER	J10	15991	8
14	CAUTION DECAL	2613FJ	---	1	44	HEX NUT	D10	15991	8
15	POS BATTERY CABLE	47311–114	---	1	45	HEX HD CAPSCREW	B1007	15991	4
16	BATTERY BOX ASSY	GRP40–08C	---	1	46	LOCKWASHER	J10	15991	4
17	–HEX HD CAPSCREW	B0607	15991	2	47	HEX NUT	D10	15991	4
18	–FLAT WASHER	K06	15991	2	48	COMBINATION BASE	41566–686	24150	1
19	–FLANGED HEX NUT	21765–314	---	2	49	HEX HD CAPSCREW	B1209	15991	2
20	–BATTERY BOX LID	42113–012	24150	1	50	LOCKWASHER	J12	15991	2
21	–GROUND CABLE ASSY	47311–064	---	1	51	HEX NUT	D12	15991	2
22	–12V BATTERY	SEE OPTIONS LIST	REF		52	FLAT WASHER	K12	15991	2
23	–BATTERY TAG	38818–506	---	1		NOT SHOWN:			
24	–BATTERY BOX	42431–030	24150	1		ENGINE STARTUP TAG	38816–269	---	1
25	–FLANGED HEX NUT	21765–314	---	8		OPTIONAL:			
26	–T TYPE LOCKWASHER	BL06	15991	1		*12V BATTERY	29331–506	---	1
27	–STUD MOUNT	24631–006	---	4		WHEEL KIT	GRP30–248F	---	1
28	HEX HD CAPSCREW	B0604	15991	10					
29	FLAT WASHER	K06	15991	10					
30	FLANGED HEX NUT	21765–314	---	10					

* INDICATES PARTS RECOMMENDED FOR STOCK

SECTION DRAWING

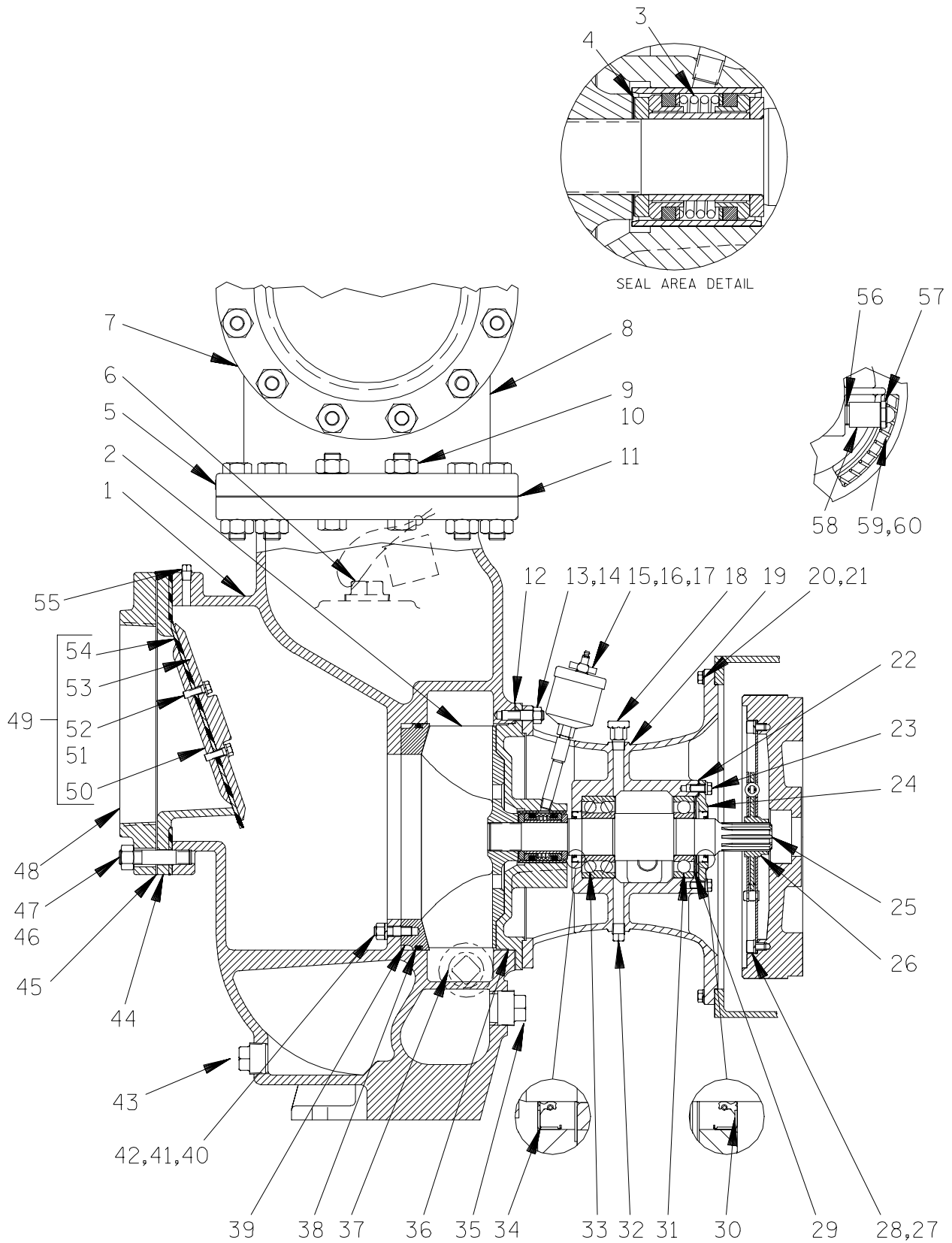

Figure 2. Pump End Assembly 810A2-(F5L)

PARTS LIST
Pump End Assembly 810A2--(F5L)

ITEM NO.	PART NAME	PART NUMBER	MAT'L CODE	QTY	ITEM NO.	PART NAME	PART NUMBER	MAT'L CODE	QTY
1	PUMP CASING	38224-704	10010	1	*	- SEAL LINER	7408	14010	REF
2	* IMPELLER	38615-073	11010	1	37	PIPE PLUG	P24	10009	1
3	* SEAL ASSY	GS1500	---	1	38	* WEAR PLT O-RING	S1865	---	1
4	* IMPELLER SHIM SET	5091	17090	REF	39	* WEAR PLATE	38691-860	10010	1
5	DISCHARGE STICKER	6588BJ	---	1	40	STUD	C0808	15991	3
6	FILL PLUG ASSY	48271-069	---	1	41	LOCKWASHER	J08	15991	3
7	DISCHARGE FLANGE	2751	10010	1	42	HEX NUT	D08	15991	3
8	FLANGED ELBOW	S5016	---	1	43	CASING DRAIN PLUG	P20	10009	1
9	HEX HD CAPSCREW	B1414	15991	24	44	CHECK VALVE SEAT	3286	10010	1
10	HEX NUT	D14	15991	24	45	* SUCT FLANGE GASKET	2751G	18000	1
11	* DISCH FLANGE GSKT	2751G	18000	2	46	STUD	C1215	15991	12
12	* CASING GASKET SET	48211-051	---	1	47	HEX NUT	D12	15991	12
13	STUD	C0809	15991	8	48	SUCTION FLANGE	2751	10010	1
14	HEX NUT	D08	15991	8	49	CHECK VALVE ASSY	3289	---	1
15	SEAL GREASE CUP	S1509	---	1	50	- VALVE WEIGHT	3287	10010	1
16	PIPE COUPLING	AE04	15079	1	51	- HEX HD CAPSCREW	B0605	17000	2
17	HEAVY PIPE NIPPLE	THA0412	15079	1	52	- LOCKWASHER	J06	17000	2
18	AIR VENT	S1703	---	1	53	- VALVE WEIGHT	3288	11000	1
19	INTERMEDIATE	38263-614	10010	1	54	* -CHECK VALVE GSKT	3290	19080	1
20	LOCKWASHER	21171-511	---	12	55	PIPE PLUG	P04	15079	1
21	CAPSCREW	22645-164	---	14	56	PIPE NIPPLE	T12	15079	1
22	* BEARING GASKET	5413G	18000	1	57	SIGHT GAUGE	S1471	---	1
23	HEX HD CAPSCREW	B0604	15991	4	58	PIPE COUPLING	AE12	15079	1
24	BEARING CAP	4185A	10010	1	59	INTERM GUARD	42381-031	24152	1
25	* IMPELLER SHAFT	38525-001	16040	1	60	INTERM GUARD	42381-032	24152	1
26	DRIVE PLATE ASSEMBLY	24521-165	---	1	NOT SHOWN:				
27	LOCKWASHER	21171-511	---	8		SUCTION STICKER	6588AG	---	1
28	SOC HD CAPSCREW	22644-215	---	8		STRAINER	3756	---	1
29	* WAVY WASHER	23963-327	---	1		NAME PLATE	38818-024	13990	1
30	* OIL SEAL	25258-622	---	1		DRIVE SCREW	BM#04-03	17000	4
31	* OUTBOARD BEARING	S1077	---	1		LUBE DECAL	38816-079	---	1
32	PEDESTAL DRAIN PLUG	P06	15079	1		INSTRUCTION TAG	38817-085	---	1
33	* INBOARD BEARING	23421-461	---	1		PRIMING STICKER	6588AH	---	1
34	* OIL SEAL	25258-622	---	1		GREASE CUP INSTR	6588BD	---	1
35	CASING DRAIN PLUG	P24	10009	1		G-R DECAL	GR-06	---	1
36	SEAL PLATE ASSY	42111-068	---	1					

* INDICATES PARTS RECOMMENDED FOR STOCK

PUMP AND SEAL DISASSEMBLY AND REASSEMBLY

Review all SAFETY information in Section A.

Follow the instructions on all tags, label and decals attached to the pump.

This pump requires little service due to its rugged, minimum-maintenance design. However, if it becomes necessary to inspect or replace the wearing parts, follow these instructions which are keyed to the sectional views (see Figures 1, 2 and 3) and the accompanying parts lists.

This manual will alert personnel to known procedures which require special attention, to those which could damage equipment, and to those which could be dangerous to personnel. However, this manual cannot possibly anticipate and provide detailed precautions for every situation that might occur during maintenance of the unit. Therefore, it is the responsibility of the owner/maintenance personnel to ensure that **only** safe, established maintenance procedures are used, and that any procedures not addressed in this manual are performed **only** after establishing that neither personal safety nor pump integrity are compromised by such practices.

Before attempting to service the pump, switch off the engine ignition and disconnect the positive battery cable to ensure that the pump will remain inoperative. Close all valves in the suction and discharge lines.

For engine disassembly and repair, consult the literature supplied with the engine, or contact your local Deutz engine representative.



Before attempting to open or service the pump:

1. Familiarize yourself with this manual.
2. Switch off the engine ignition and disconnect the positive battery cable to ensure that the pump will remain inoperative.

3. Allow the pump to completely cool if overheated.
4. Check the temperature before opening any covers, plates, or plugs.
5. Close the suction and discharge valves.
6. Vent the pump slowly and cautiously.
7. Drain the pump.

Suction Check Valve Removal

(Figure 2)

Before attempting to service the pump, remove the pump casing drain plug (43) and drain the pump. Clean and reinstall the drain plug.

For access to the check valve (49), remove the suction piping. Remove the nuts (47) and separate the suction flange (48) and gasket (45) from the pump casing (1). Replace the suction flange gasket as required.

Pull the check valve seat (44) and check valve assembly from the suction port.

Inspect the check valve parts for wear or damage. If replacement is required, remove the hardware (51 and 52) and separate the check valve gasket (54) and weights (50 and 53).

Pump Disassembly

(Figure 2)

To service the wear plate (39), impeller (2), or seal assembly (3), the pump casing (1) must be separated from the base and intermediate (19). See Figure 1 and remove the hardware (49, 50, 51 and 52) securing the pump casing to the base (48).

Support the pump casing using a suitable hoist and sling. Remove the nuts (14) and separate the pump casing and casing gasket set (12) from the seal plate (36) and intermediate (19). Replace the gasket set as required.

Tie and tag any leveling shims used under the pump casing mounting feet to ease reassembly. For ease of reassembly, tie and tag the gasket set or measure and record their thickness.



Use lifting and moving equipment in good repair and with adequate capacity to prevent injuries to personnel or damage to equipment. Suction and discharge hoses and piping must be removed from the pump before lifting.

Inspect the wear plate (39) and replace it if scored or worn. To remove the wear plate, disengage the hardware (41 and 42) from the wear plate studs (40) and pull the wear plate and O-ring (38) from the pump casing. Remove the O-ring.

Impeller Removal

(Figure 2)

Before removing the impeller, turn the cross arm on the automatic lubricating grease cup (15) clockwise until it rests against the cover (see Figure 5 in **LUBRICATION**). This will prevent the grease in the cup from escaping when the impeller is removed.

Use an impeller wrench to remove the impeller. If an impeller wrench is not available, place a block of wood against one of the vanes and strike it sharply with a hammer. **Be careful** not to damage the vane. Unscrew the impeller in a counterclockwise direction (when facing the impeller). Use caution when removing the impeller; tension on the seal spring will be released as the impeller is unscrewed.

Inspect the impeller and replace it if cracked or badly worn. Slide the impeller adjusting shims (4) off the shaft (25). For ease of reassembly, tie and tag the shims or measure and record their thickness.

Seal Removal

(Figure 2)

Make certain that the cross arm on the grease cup (15) has been turned down against the cover before removing the seal assembly.

For ease of disassembly, the seal and seal plate (36) may be removed as a single unit. Before attempting to remove the seal plate, remove the seal cavity grease cup and piping (15, 16 and 17).

Remove the outer rotating element. Slide the seal plate and seal parts off the shaft as a unit. Use caution not to drop or damage the seal parts while sliding them off the shaft.

Carefully remove the outer stationary seat, packing ring, seal washer and seal spring from the seal plate. Remove the spacer sleeve, inner seal washer, packing ring, stationary seat and rotating element.

NOTE

An alternate method of removing the seal without removing the seal plate is to remove the outer rotating element, and use a pair of stiff wires with hooked ends to pull the remaining seal parts out of the seal plate.

Inspect the seal liner for wear or grooves that could cause leakage or damage to the seal packing rings. The seal liner is secured by a press fit into the seal plate and does not normally require replacement. If replacement is required, see **Seal Installation**.

If no further disassembly is required, refer to **Seal Installation**.

Separating Intermediate And Drive Assembly From Engine

(Figure 2)

If it is necessary to separate the intermediate and drive assembly from the engine, support the intermediate using a suitable hoist and sling. Remove the hardware (20 and 21) securing the intermediate (19) and guards (59 and 60) to the engine bellhousing. Separate the assemblies by pulling the intermediate straight away from the engine.

It is not necessary to remove the drive plate assembly (26) from the engine flywheel unless replacement is necessary. To remove the drive plate assembly, remove the hardware (27 and 28) securing it to the flywheel.

Shaft And Bearing Removal And Disassembly

(Figure 2)

When the pump is properly operated and maintained, the shaft and bearings should not require disassembly. Disassemble the shaft and bearings **only** when there is evidence of wear or damage.

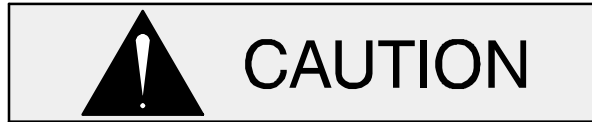

Shaft and bearing disassembly in the field is not recommended. These operations should be performed only in a properly equipped shop by qualified personnel.

Before attempting to disassemble the intermediate, remove the drain plug (32) and drain the intermediate. Clean and reinstall the drain plug.

Remove the hardware (23) and separate the bearing cap (24) and gasket set (22) from the intermediate. Tie and tag the bearing gaskets or measure and record their thickness for ease of reassembly.

Remove the wavy washer (29). Press the outboard oil seal (30) from the bearing cap.

Place a block of wood against the impeller end of the shaft (25) and tap the shaft and assembled bearings out of the intermediate. **Be careful** not to damage the shaft.

Place the intermediate on a level surface with the drive end down and press the inboard oil seal (34) from the intermediate bore.

After removing the shaft and bearings, clean and inspect the bearings **in place** as follows.



To prevent damage during removal from the shaft, it is recommended that bearings be cleaned and inspected **in place**. It is **strongly** recommended that the bearings be replaced **any** time the shaft and bearings are removed.

Clean the intermediate, shaft and all component parts (except the bearings) with a soft cloth soaked

in cleaning solvent. Inspect the parts for wear or damage and replace as necessary.



Most cleaning solvents are toxic and flammable. Use them only in a well ventilated area free from excessive heat, sparks, and flame. Read and follow all precautions printed on solvent containers.

Clean the bearings thoroughly in **fresh** cleaning solvent. Dry the bearings with filtered compressed air and coat with light oil.

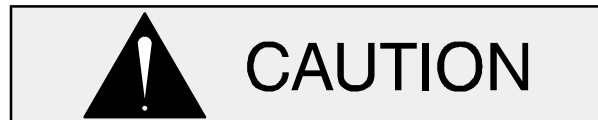

Bearings must be kept free of all dirt and foreign material. Failure to do so will greatly shorten bearing life. **Do not** spin dry bearings. This may scratch the balls or races and cause premature bearing failure.

Rotate the bearings by hand to check for roughness or binding and inspect the balls. If rotation is rough or the balls are discolored, replace the bearings.

The bearing tolerances provide a tight press fit onto the shaft and a snug slip fit into the intermediate. Replace the bearings, shaft, or intermediate if the proper bearing fit is not achieved.

If replacement is required, use a bearing puller to remove the bearings from the shaft.

Shaft and Bearing Reassembly And Installation

(Figure 2)

Clean and inspect the bearings as indicated in **Shaft and Bearing Removal and Disassembly**.



To prevent damage during removal from the shaft, it is recommended that bearings be cleaned and inspected **in place**. It is

strongly recommended that the bearings be replaced **any** time the shaft and bearings are removed.

Inspect the shaft for distortion, nicks or scratches, or for thread damage on the impeller end. Dress small nicks and burrs with a fine file or emery cloth. Replace the shaft if defective.

The bearings (31 and 33) may be heated to ease installation. An induction heater, hot oil bath, electric oven, or hot plate may be used to heat the bearings. Bearings should **never** be heated with a direct flame or directly on a hot plate.

NOTE

If a hot oil bath is used to heat the bearings, both the oil and the container must be **absolutely** clean. If the oil has been previously used, it must be **thor-**

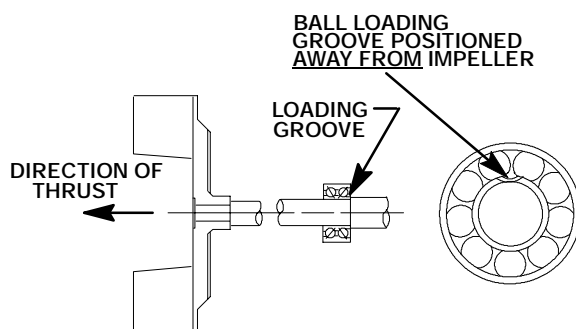

INSTALLATION OF NEW DEPARTURE OR
BCA/FEDERAL MOGAL 5300W SERIES BEARINGS
(OPEN OR ENCLOSED IMPELLERS)

oroughly filtered.

Heat the bearings to a uniform temperature **no higher than** 250°F (120°C), and slide the bearings onto the shaft, one at a time, until they are fully seated. This should be done quickly, in one continuous motion, to prevent the bearings from cooling and sticking on the shaft.



Use caution when handling hot bearings to prevent burns.

NOTE

Position the inboard bearing (33) on the shaft as indicated by the following illustrations.

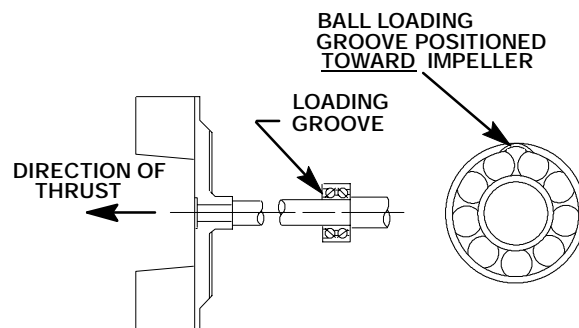

INSTALLATION OF MRC/SKF 5300M OR
FAFNIR 5300W SERIES BEARINGS
(OPEN OR ENCLOSED IMPELLERS)

Figure 3. Bearing Installation

After the bearings have been installed and allowed to cool, check to ensure that they have not moved out of position in shrinking. If movement has occurred, use a suitably sized sleeve and a press to reposition the bearings against the shaft shoulders.

If heating the bearings is not practical, use a suitably sized sleeve and an arbor (or hydraulic) press to install the bearings on the shaft.



When installing the bearings onto the shaft, **never** press or hit against the outer

race, balls, or ball cage. Press **only** on the inner race.

Slide the shaft and assembled bearings into the intermediate bore from the drive end until the inboard bearing (33) is fully seated against the bore shoulder.



When installing the shaft and bearings into the bearing bore, push against the outer race. **Never** hit the balls or ball cage.

Lubricate the shaft and press the inboard oil seal (34) into the intermediate (19) with the lip posi-

tioned as shown in Figure 2. Use caution not to roll or damage the lip of the oil seal during installation.

Press the outboard oil seal (30) into the bearing cap (24) with the lip positioned as shown in Figure 2.

Slide the wavy washer (29) onto the shaft. Install the bearing gasket (22). Lubricate the shaft and slide the assembled bearing cap and oil seal onto the shaft until seated against the intermediate. Use caution not to roll or damage the lip of the oil seal during installation. Secure the bearing cap with the hardware (23).

Lubricate the bearings as indicated in **LUBRICATION** at the end of this section.

Securing Intermediate And Drive Assembly To Engine

(Figure 2)

If the drive plate assembly (26) was removed, secure it to the engine flywheel with the attaching hardware (27 and 28).

Slide the splined end of the shaft (25) into the drive plate. Position the intermediate (19) against the engine bellhousing with the air vent at the top, and secure the intermediate and guards (59 and 60) to the bellhousing with the hardware (20 and 21).

NOTE

Position the guard (60) over the sight gauge (57).

Seal Reassembly and Installation

(Figures 2 and 4)

Inspect the pump casing, seal plate, seal liner and the impeller shaft for burrs or sharp corners, and remove any that exist. Replace the seal liner if wear or grooves exist which could cause leakage or damage to the seal packing rings.

To replace the seal liner, position the seal plate (36) on the bed of an arbor (or hydraulic) press and use a new seal liner to press the old liner out. After the new liner is properly installed, drill a 1/4-inch diameter (6,35 mm) hole through the liner to permit the flow of lubricant to the seal assembly. **Be careful**

to center the drill in the threaded hole so not to damage the threads in the pump casing. Deburr the hole from the inside of the seal liner after drilling.

Slide the seal plate onto the shaft (25) and align the lubrication hole in the seal plate with the opening in the intermediate. Temporarily secure the seal plate to the intermediate using two capscrews and nuts (1/2-UNC by 1-1/2 inch long, not supplied).

Clean the seal cavity and shaft with a cloth soaked in fresh cleaning solvent.



Most cleaning solvents are toxic and flammable. Use them only in a well ventilated area free from excessive heat, sparks, and flame. Read and follow all precautions printed on solvent containers.

The seal is not normally reused because wear patterns on the finished faces cannot be realigned during reassembly. This could result in premature failure. If necessary to reuse an old seal in an emergency, **carefully** wash all metallic parts in **fresh** cleaning solvent and allow to dry thoroughly.

Handle the seal parts with extreme care to prevent damage. Be careful not to contaminate precision finished faces; even fingerprints on the faces can shorten seal life. If necessary, clean the faces with a non-oil based solvent and a clean, lint-free tissue. Wipe **lightly** in a concentric pattern to avoid scratching the faces.

Inspect the seal components for wear, scoring, grooves, and other damage that might cause leakage. Clean and polish the seal spacer sleeve, or replace it if there are nicks or cuts on either end. If any components are worn, replace the complete seal; **never mix old and new seal parts.**

If a replacement seal is being used, remove it from the container and inspect the precision finished faces to ensure that they are free of any foreign matter.

To ease installation of the seal, lubricate the packing rings and seal liner with water or a very **small** amount of oil, and apply a drop of light lubricating

oil on the finished faces. Assemble the seal as follows, (see Figure 4).

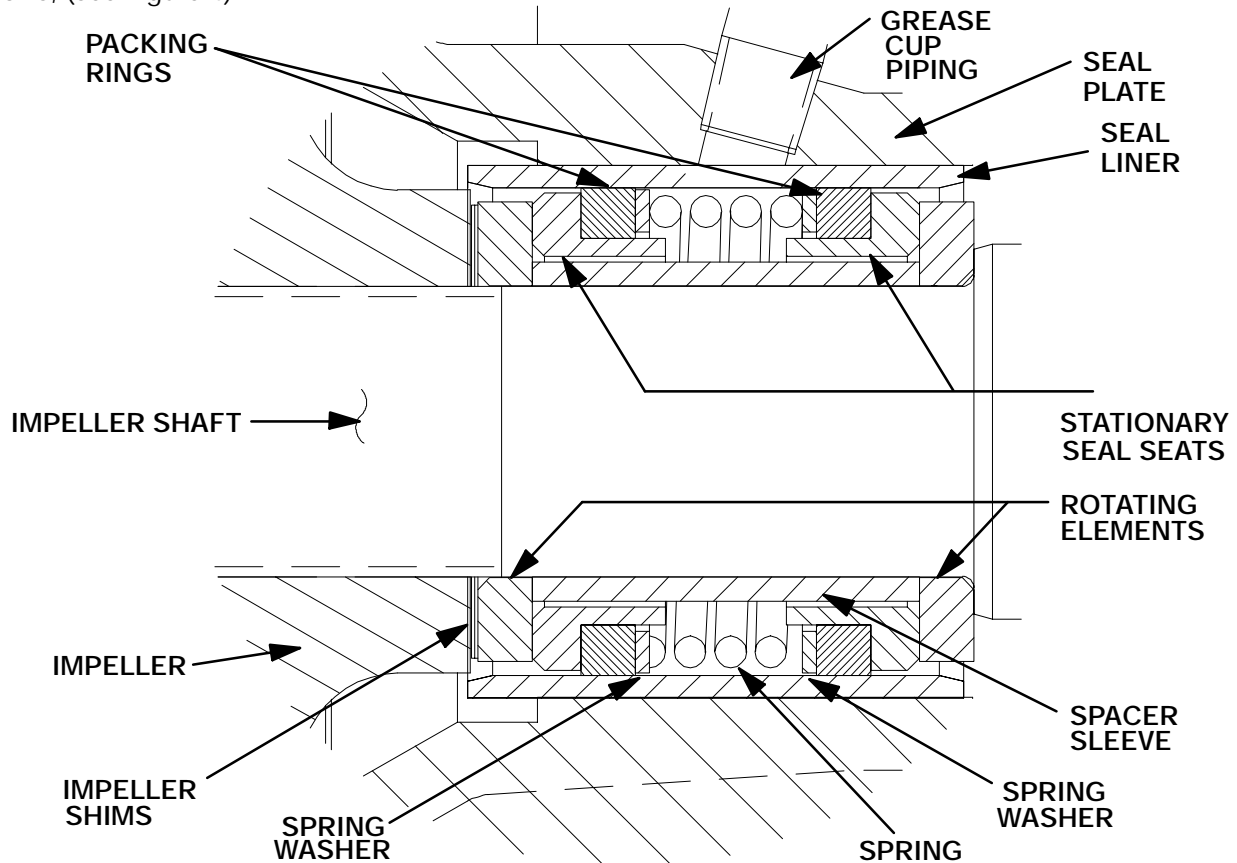

Figure 4. GS1500 Seal Assembly



This seal is not designed for operation at temperatures above 110° F (43°C). Do not use at higher operating temperatures.

Slide the inboard rotating element onto the shaft until the chamfered side seats against the shaft shoulder.

Subassemble the inboard stationary seat, packing ring and spring washer. Press this subassembly into the lubricated seal liner. A push tube cut from a length of plastic pipe would aid this installation. The O.D. of the pipe should be approximately the same diameter as the O.D. of the seal spring.

Install the spacer sleeve and spring.

Subassemble the outboard stationary seat, packing ring and spring washer. Press this subassembly into the lubricated seal liner.

Install the outboard rotating element with the chamfered side facing the impeller.

Reinstall the automatic grease cup and piping (15, 16 and 17) in the seal plate. After the impeller has been installed, lubricate the seal as indicated in **LUBRICATION**.

Impeller Installation

(Figure 2)

Inspect the impeller (2), and replace it if cracked or badly worn. Install the same thickness of impeller shims (4) as previously removed and screw the impeller onto the shaft until tight.



The shaft and impeller threads **must** be completely clean before reinstalling the impeller. Even the slightest amount of dirt on the threads can cause the impeller to seize

to the shaft, making future removal difficult or impossible without damage to the impeller or shaft.

A clearance of .020 to .040 inch (0,51 to 1,02 mm) between the impeller and the seal plate is recommended for maximum pump efficiency. Measure this clearance and add or subtract impeller shims until it is reached.

NOTE

The seal plate must be tight against the intermediate while setting the back impeller clearance.

Pump Reassembly

(Figure 2)

If the wear plate (39) was removed for replacement, install the O-ring (38) in the groove in the wear plate and lubricate it to ease installation. Press the wear plate into the pump casing, and secure it to the pump casing with the hardware (41 and 42).

Remove the two capscrews temporarily securing the seal plate, and install the same thickness of pump casing gaskets (12) as previously removed. Secure the pump casing to the intermediate with the nuts (14).

A clearance of .010 to .020 inch (0,25 to 0,51 mm) between the impeller and the wear plate is also recommended for maximum pump efficiency. Reach through the suction opening with a feeler gauge and measure this clearance at three or four locations around the wear plate. Add or remove gaskets as required until the proper impeller clearance is obtained.

See Figure 1, and reinstall any leveling shims used under the pump casing mounting feet. Secure the casing to the base (48) with the hardware (49, 50, 51 and 52).

Suction Check Valve Installation

(Figure 2)

Inspect the check valve components and replace them as required. Subassemble the check valve

weights (50 and 53) and gasket (54) using the attaching hardware (51 and 52).

Secure the check valve assembly (49), valve seat (44), suction flange gasket (45) and suction flange (48) to the suction port with the nuts (47). Make sure the large valve weight (53) is toward the inside of the pump.

Check the operation of the check valve to ensure proper seating and free movement.

Final Pump Reassembly

(Figure 1)

Be sure the pump and intermediate are secure to the engine and the base.

Install the suction and discharge lines and open all valves. Make certain that all piping connections are tight, properly supported and secure.

NOTE

If the discharge elbow (8, Figure 2) was removed, position two of the capscrews (9) on the underside of the elbow as shown in Figure 2.

Be sure the pump and engine have been properly lubricated, see **LUBRICATION**.

Before starting the pump, remove the fill plug (6, Figure 2) and fill the pump casing with clean liquid. Reinstall the fill plug and tighten. (see **OPERATION**, Section C).

LUBRICATION

Seal Assembly

(Figure 2)

Fill the grease cup (15) through the grease fitting with No. 2 lithium base grease until grease escapes from the relief hole. Turn the grease cup arm counterclockwise until it is at the top of the stem; this will release the spring to apply grease to the seal (see Figure 5).

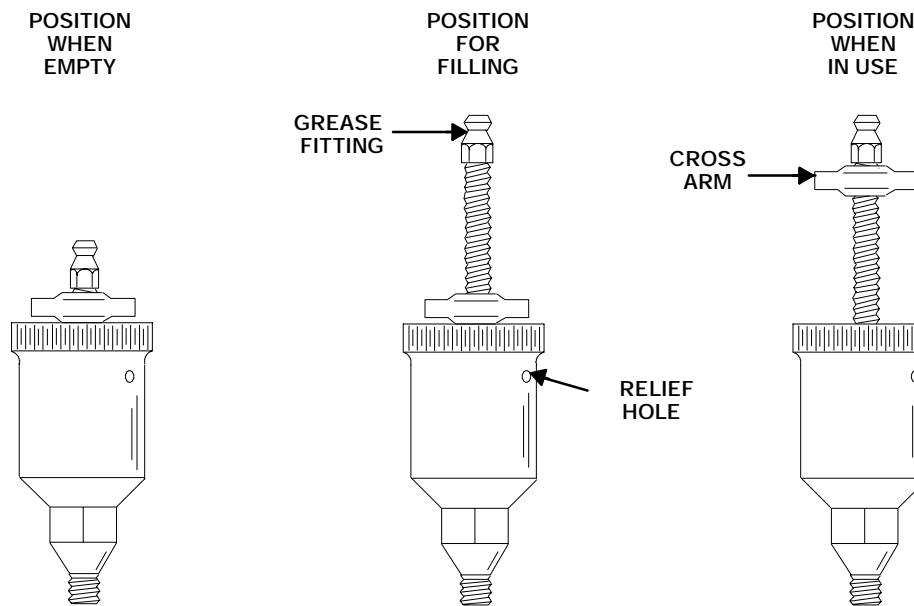
**NOTE:**

When installing a new grease cup, lubricate the cup as indicated on the installation tag furnished with the grease cup.

Figure 5. Automatic Lubricating Grease Cup

Bearings

(Figure 2)

The intermediate was fully lubricated when shipped from the factory. Check the oil level regularly through the sight gauge (57) and maintain it at the middle of the gauge. When lubrication is required, add SAE No. 30 non-detergent oil through the hole for the air vent (18). **Do not** over-lubricate. Over-lubrication can cause the bearings to over-heat, resulting in premature bearing failure.

Under normal conditions, drain the intermediate once each year and refill with clean oil. Change the oil more frequently if the pump is operated continuously or installed in an environment with rapid temperature change.



Monitor the condition of the bearing lubricant regularly for evidence of rust or moisture condensation. This is especially important in areas where variable hot and cold temperatures are common.

For cold weather operation, consult the factory or a lubricant supplier for the recommended grade of oil.

Engine

Consult the literature supplied with the engine, or contact your local Deutz engine representative.

**For U.S. and International Warranty Information,
Please Visit www.grpumps.com/warranty
or call:
U.S.: 419-755-1280
International: +1-419-755-1352**

**For Canadian Warranty Information,
Please Visit www.grcanada.com/warranty
or call:
519-631-2870**