

---

# **10**SERIES™

---

## **INSTALLATION, OPERATION, PARTS LIST, AND MAINTENANCE MANUAL**

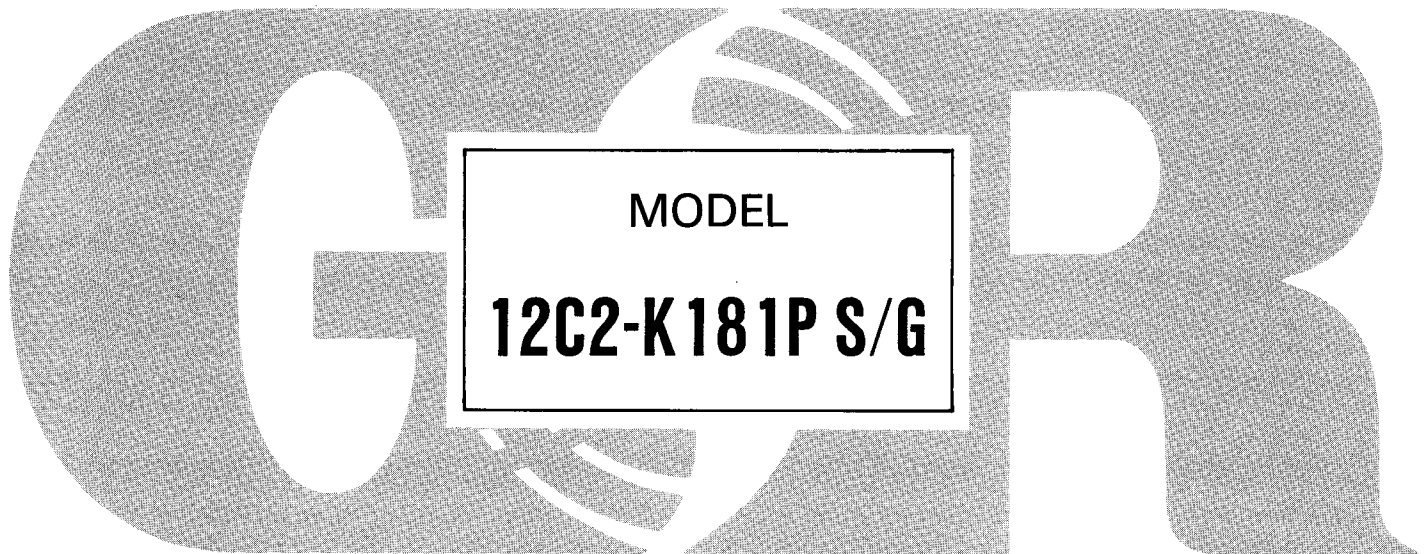

**THE GORMAN-RUPP COMPANY • MANSFIELD, OHIO**

GORMAN-RUPP OF CANADA LIMITED • ST. THOMAS, ONTARIO, CANADA

Printed in U.S.A.

Copyright by the Gorman-Rupp Company



# TABLE OF CONTENTS

INTRODUCTION . . . . .	I-1
WARNINGS - SECTION A . . . . .	A-1
INSTALLATION - SECTION B . . . . .	B-1
Pump Dimensions . . . . .	B-1
PREINSTALLATION INSPECTION . . . . .	B-2
POSITIONING PUMP . . . . .	B-3
Lifting . . . . .	B-3
Mounting . . . . .	B-3
Clearance . . . . .	B-3
SUCTION AND DISCHARGE PIPING . . . . .	B-4
Materials . . . . .	B-4
Line Configuration . . . . .	B-4
Connections to Pump . . . . .	B-4
Gauges . . . . .	B-4
SUCTION LINES . . . . .	B-4
Fittings . . . . .	B-5
Strainers . . . . .	B-5
Sealing . . . . .	B-5
Suction Lines In Sumps . . . . .	B-5
Suction Line Positioning . . . . .	B-6
DISCHARGE LINES . . . . .	B-6
Siphoning . . . . .	B-6
Valves . . . . .	B-7
Bypass Lines . . . . .	B-7
OPERATION - SECTION C . . . . .	C-1
PRIMING . . . . .	C-1
STARTING . . . . .	C-2
OPERATION . . . . .	C-2
Lines With a Bypass . . . . .	C-2
Lines Without a Bypass . . . . .	C-3
Leakage . . . . .	C-3
Liquid Temperature And Overheating . . . . .	C-3
Strainer Check . . . . .	C-3
Pump Vacuum Check . . . . .	C-4
STOPPING . . . . .	C-4
Cold Weather Preservation . . . . .	C-4
PUMP TROUBLESHOOTING - SECTION D . . . . .	D-1
PUMP MAINTENANCE AND REPAIR - SECTION E . . . . .	E-1
PERFORMANCE CURVE . . . . .	E-1
PUMP MODEL - PARTS LIST . . . . .	E-3
PUMP END ASSY - PARTS LIST . . . . .	E-5
PUMP AND SEAL DISASSEMBLY AND REASSEMBLY . . . . .	E-6
Back Cover Removal . . . . .	E-6
Suction Check Valve Removal . . . . .	E-7
Impeller Removal . . . . .	E-7
Seal Disassembly . . . . .	E-7
Pump Disassembly . . . . .	E-7
Separating Intermediate From Engine . . . . .	E-8
Securing Intermediate To Engine . . . . .	E-8
Seal Reassembly . . . . .	E-9
Impeller Reassembly And Adjustment . . . . .	E-11
Suction Check Valve Installation . . . . .	E-11
Back Cover Installation . . . . .	E-12
Final Pump Reassembly . . . . .	E-12
LUBRICATION . . . . .	E-12
Seal Assembly . . . . .	E-12
Engine . . . . .	E-13



This Installation, Operation, and Maintenance Manual is designed to help you achieve the best performance and longest life from your Gorman-Rupp pump.

This pump is a 10 Series, semi-open impeller, self-priming centrifugal model with a suction check valve. The pump is designed to pump dirty water containing specified entrained solids. The basic materials of construction for wetted parts is gray iron with ductile iron impeller and steel wearing parts.

If there are any questions regarding the pump or its application which are not covered in this manual or in other literature accompanying this unit, please contact your Gorman-Rupp distributor, or write:

The Gorman-Rupp Company	or	Gorman-Rupp of Canada Limited
P.O. Box 1217		70 Burwell Road
Mansfield, Ohio 44901		St. Thomas, Ontario N5P 3R7

For information or technical assistance on the engine, contact the engine manufacturer's local dealer or representative.

The following are used to alert maintenance personnel to procedures which require special attention, to those which could damage equipment, and to those which could be dangerous to personnel:

**NOTE**

Instructions to aid in installation, operation, and maintenance or which clarify a procedure.

**CAUTION**

<p>Instructions which must be followed to avoid causing damage to the product or other equipment incidental to the installation. These instructions describe the requirements and the possible damage which could result from failure to follow the procedures.</p>
---

**WARNING**

```

////////////////////////////////////
//
// These instructions must be followed to avoid causing in- //
// jury or death to personnel, and describe the procedure //
// required and the injury which could result from failure //
// to follow the procedure. //
// //
////////////////////////////////////

```



WARNINGS

WARNINGS - SECTION A

THESE WARNINGS APPLY TO 10 SERIES ENGINE DRIVEN PUMPS. REFER TO THE MANUAL ACCOMPANYING THE ENGINE BEFORE ATTEMPTING TO BEGIN OPERATION.

WARNING

```

////////////////////////////////////
//
// Before attempting to open or service the pump:
//
// 1. Familiarize yourself with this manual.
// 2. Disconnect the engine spark plug wire to ensure
// that the pump will remain inoperative.
// 3. Allow the pump to cool if overheated.
// 4. Vent the pump slowly and cautiously.
// 5. Close the suction and discharge valves.
// 6. Check the temperature before opening any covers,
// plates, or plugs.
// 7. Drain the pump.
//
////////////////////////////////////

```

WARNING

```

////////////////////////////////////
//
// This pump is designed to pump dirty water with specified
// entrained solids. Do not attempt to pump volatile, cor-
// rosive, or flammable liquids which may damage the pump
// or endanger personnel as a result of pump failure.
//
////////////////////////////////////

```

WARNING

```

////////////////////////////////////
//
// After the pump has been installed, make certain that the
// pump and all piping connections are tight, properly sup-
// ported and secure before operation.
//
////////////////////////////////////

```

WARNING

```

////////////////////////////////////
//
// Do not operate the pump against a closed discharge valve
// for long periods of time. This could bring the liquid
// to a boil, build pressure, and cause the pump to rupture
// or explode.
//
////////////////////////////////////

```

WARNINGS

WARNING

```

////////////////////////////////////
//
// Do not remove plates, covers, gauges, pipe plugs, or
// fittings from an overheated pump. Vapor pressure within
// the pump can cause parts being disengaged to be ejected
// with great force. Allow the pump to cool before servic-
// ing.
//
////////////////////////////////////

```

WARNING

```

////////////////////////////////////
//
// Fuel used by internal combustion engines presents an ex-
// treme explosion and fire hazard. Make certain that all
// fuel lines are securely connected and free of leaks.
// Never refuel a hot or running engine. Avoid overfilling
// the fuel tank. Always use the correct type of fuel.
//
////////////////////////////////////

```

WARNING

```

////////////////////////////////////
//
// Do not operate an internal combustion engine in an ex-
// plosive atmosphere. When operating internal combustion
// engines in an enclosed area, make certain that exhaust
// fumes are piped to the outside. These fumes contain
// carbon monoxide, a deadly gas that is colorless,
// tasteless, and odorless.
//
////////////////////////////////////

```

WARNING

```

////////////////////////////////////
//
// Never tamper with the governor to gain more power. The
// governor establishes safe operating limits that should
// not be exceeded. The maximum continuous operating speed
// is 2600 RPM.
//
////////////////////////////////////

```

WARNING

```

////////////////////////////////////
//
// Use lifting and moving equipment in good repair and with
// adequate capacity to prevent injuries to personnel or
// damage to equipment. Be sure chains or cables are posi-
// tioned so they will not damage the pump, and the load
// will be balanced. Suction and discharge hoses MUST be
// removed before lifting.
//
////////////////////////////////////

```



---

---

## INSTALLATION - SECTION B

Since pump installations are seldom identical, this section offers only general recommendations and practices required to inspect, position, and arrange the pump and piping.

Most of the information pertains to a standard **static lift application** where the pump is positioned above the free level of liquid to be pumped.

If installed in a **flooded suction application** where the liquid is supplied to the pump under pressure, some of the information such as mounting, line configuration, and priming must be tailored to the specific application. Since the pressure supplied to the pump is critical to performance and safety, **be sure** to limit the incoming pressure to 50% of the maximum permissible operating pressure as shown on the pump performance curve. (See Section E, Page 1). If the pump is fitted with a Gorman-Rupp double grease lubricated seal, the maximum incoming pressure must be reduced to 10 p.s.i..

For further assistance, contact your Gorman-Rupp distributor or the Gorman-Rupp Company.

### Pump Dimensions

See Figure 1 for the approximate physical dimensions of this pump.

## OUTLINE DRAWING

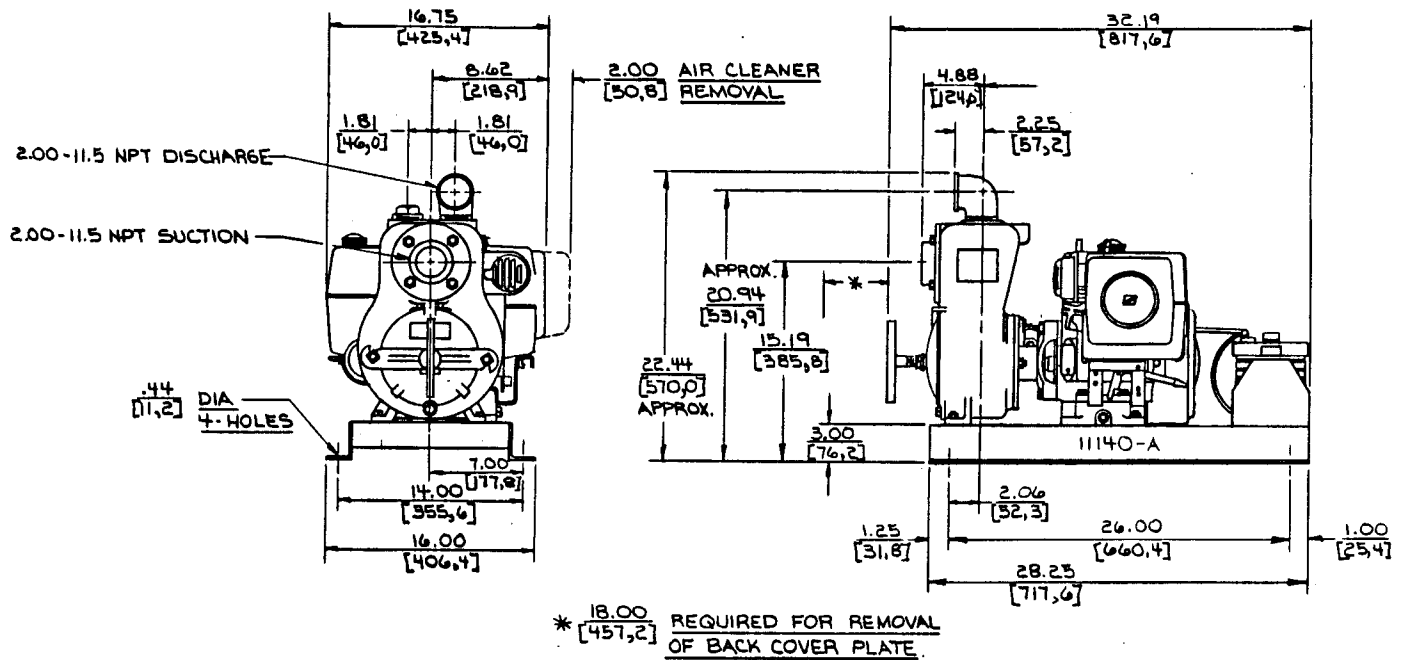

DIMENSIONS  
TOP - INCHES  
BOTTOM - MILLIMETERS

POWERED BY KOHLER K181P S/G ENGINE

Figure 1. Pump Model 12C2-K181P S/G

## PREINSTALLATION INSPECTION

The pump assembly was inspected and tested before shipment from the factory. Before installation, inspect the pump for damage which may have occurred during shipment. Check as follows:

- Inspect the pump for cracks, dents, damaged threads, and other obvious damage.
- Check for and tighten loose bolts, nuts, capscrews, and other attaching hardware. Since gaskets tend to shrink after drying, check for and tighten loose nuts and capscrews securing mating surfaces.
- Carefully read all tags, decals, and markings on the pump assembly, and follow the instructions indicated.

- 
- 
- d. Check all lubricant levels and lubricate as necessary. Refer to LUBRICATION in the MAINTENANCE AND REPAIR section of this manual and perform duties as instructed.
  - e. If the pump and engine have been stored for more than 12 months, some of the components or lubricants may have exceeded their maximum shelf life. These **must be inspected or replaced** to ensure maximum pump service.

If the maximum shelf life has been exceeded, or if anything appears to be abnormal, contact your Gorman-Rupp distributor or the factory to determine the repair or updating policy. **Do not** put the pump into service until appropriate action has been taken.

## POSITIONING PUMP

### Lifting

Use lifting equipment with a capacity of at least **1,300 pounds**. This pump weighs approximately **260 pounds**, not including the weight of accessories and wheel kit. Customer installed equipment such as suction and discharge hoses **must** be removed before attempting to lift.

### CAUTION

The pump assembly can be seriously damaged if the cables or chains used to lift and move the unit are improperly wrapped around the pump.

### Mounting

Locate the pump in an accessible place as close as practical to the liquid being pumped. Level mounting is essential for proper operation. The pump may have to be supported or shimmed to provide for level operation or to eliminate vibration.

If the pump has been mounted on a moveable base, make certain the base is stationary by setting the brake and blocking the wheels before attempting to operate the pump.

### Clearance

When positioning the pump, allow a clearance of at least **18 inches** in front of the back cover assembly to permit removal of the back cover, and of the rotating assembly, which must be removed through the back of the pump.

---

---

## SUCTION AND DISCHARGE PIPING

### Materials

Either pipe or hose may be used for suction and discharge lines; however, the materials must be compatible with the liquid being pumped. If hose is used in suction lines, it must be the rigid-wall, reinforced type to prevent collapse under suction. Using piping couplings in suction lines is not recommended.

### Line Configuration

Keep suction and discharge lines as straight as possible to minimize friction losses. Make minimum use of elbows and fittings, which substantially increase friction loss. If elbows are necessary, use the long-radius type to minimize friction loss.

### Connections to Pump

Before tightening a connecting flange, align it exactly with the pump port. Never pull a pipe line into place by tightening the flange bolts and/or couplings.

Lines near the pump must be independently supported to avoid strain on the pump which could cause excessive vibration, decreased bearing life, and increased shaft and seal wear. If hose-type lines are used, they should have adequate support to secure them when filled with liquid and under pressure.

### Gauges

Most pumps are drilled and tapped for installing discharge pressure and vacuum suction gauges. If these gauges are desired for pumps that are not tapped, drill and tap the suction and discharge lines not less than 18 inches from the suction and discharge ports and install the lines. Installation closer to the pump may result in erratic readings.

## SUCTION LINES

To avoid air pockets which could affect pump priming, the suction line must be as short and direct as possible. When operation involves a suction lift, the line must always slope upward to the pump from the source of the liquid being pumped; if the line slopes down to the pump at any point along the suction run, air pockets will be created.

---

---

## Fittings

Suction lines should be the same size as the pump inlet. If reducers are used in suction lines, they should be the eccentric type, and should be installed with the flat part of the reducers uppermost to avoid creating air pockets. Valves are not normally used in suction lines, but if a valve is used, install it with the stem horizontal to avoid air pockets.

## Strainers

If a strainer is furnished with the pump, be certain to use it; any spherical solids which pass through a strainer furnished with the pump will also pass through the pump itself.

If a strainer is not furnished with the pump, but is installed by the pump user, make certain that the total area of the openings in the strainer is at least three or four times the cross section of the suction line, and that the openings will not permit passage of solids larger than the solids handling capability of the pump.

This pump is designed to handle up to 1 1/2 inch diameter spherical solids.

## Sealing

Since even a slight leak will affect priming, head, and capacity, especially when operating with a high suction lift, all connections in the suction line should be sealed with pipe dope to ensure an airtight seal. Follow the sealant manufacturer's recommendations when selecting and applying the pipe dope. The pipe dope should be compatible with the liquid being pumped.

## Suction Lines In Sumps

If a single suction line is installed in a sump, it should be positioned away from the wall of the sump at a distance equal to one and one-half times the diameter of the suction line.

If there is a liquid flow from an open pipe into the sump, the flow should be kept away from the suction inlet because the inflow will carry air down into the sump, and air entering the suction line will reduce pump efficiency.

If it is necessary to position inflow close to the suction inlet, install a baffle between the inflow and the suction inlet at a distance one and one-half times the diameter of the suction pipe. The baffle will allow entrained air to escape from the liquid before it is drawn into the suction inlet.

If two suction lines are installed in a single sump, the flow paths may interact, reducing the efficiency of one or both pumps. To avoid this, position the suction inlets so that they are separated by a distance equal to at least three times the diameter of the suction pipe.

Suction Line Positioning

The depth of submergence of the suction line is critical to efficient pump operation. Figure 2 shows recommended minimum submergence vs. velocity.

NOTE

The pipe submergence required may be reduced by installing a standard pipe increaser fitting at the end of the suction line. The larger opening size will reduce the inlet velocity. Calculate the required submergence using the following formula based on the increased opening size (area or diameter).

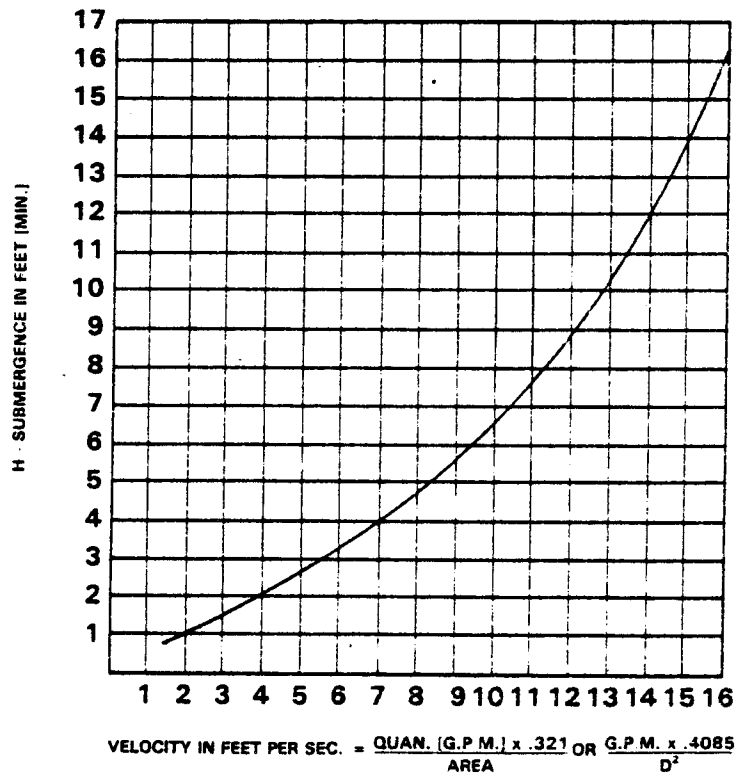

Figure 2. Recommended Minimum Suction Line Submergence Vs. Velocity

DISCHARGE LINES

Siphoning

Do not terminate the discharge line at a level lower than that of the liquid being pumped unless a siphon breaker is used in the line. Otherwise, a siphoning action causing damage to the pump could result.

## INSTALLATION

---

---

**Valves**

A check valve in the discharge line is normally recommended, but it is not necessary in low discharge head applications.

If a throttling valve is desired in the discharge line, use a valve as large as the largest pipe to minimize friction losses. Never install a throttling valve in a suction line.

With high discharge heads, it is recommended that a throttling valve and a system check valve be installed in the discharge line to protect the pump from excessive shock pressure and reverse rotation when it is stopped.

**CAUTION**

If application involves a high discharge head, gradually close the discharge throttling valve before stopping the pump.

**Bypass Lines**

If it is necessary to permit the escape of air to atmosphere during initial priming or in the repriming cycle, install a bypass line between the pump and the discharge check valve. The bypass line should be sized so that it does not affect pump discharge capacity.

Either a Gorman-Rupp automatic air release valve - which will automatically open to allow the pump to prime, and automatically close when priming is accomplished - or a hand-operated shutoff valve should be installed in the bypass line.

**NOTE**

The bypass line may clog frequently, particularly if the valve remains closed. If this condition occurs, either use a larger bypass line or leave the shutoff valve open during the pumping operation.

Do not terminate the discharge line at a level lower than that of the liquid being pumped unless a siphon breaker is used in the line. Otherwise, a siphoning action could result, causing damage to the pump.





OPERATION - SECTION C

WARNING

```

////////////////////////////////////
//
// This pump is designed to pump dirty water with specified //
// entrained solids. Do not attempt to pump volatile, cor- //
// rosive, or flammable liquids which may damage the pump //
// or endanger personnel as a result of pump failure. //
//
////////////////////////////////////

```

WARNING

```

////////////////////////////////////
//
// Never tamper with the governor to gain more power. The //
// governor establishes safe operating limits that should //
// not be exceeded. The maximum continuous operating speed //
// is 2600 RPM. //
//
////////////////////////////////////

```

PRIMING

Install the pump and piping as described in INSTALLATION. Make sure that the piping connections are tight, and that the pump is securely mounted. Check that the pump is properly lubricated (see LUBRICATION in MAINTENANCE AND REPAIR).

This pump is self-priming, but the pump should never be operated unless there is liquid in the casing.

CAUTION

<p>Never operate a self-priming pump unless there is liquid in the casing. The pump will not prime when dry. Extended operation of a dry pump will destroy the seal assembly.</p>
---

Add liquid to the pump casing when:

1. The pump is being put into service for the first time.
2. The pump has not been used for a considerable length of time.
3. The liquid in the pump casing has evaporated.

Once the pump casing has been filled, the pump will prime and reprime as necessary.

WARNING

```

////////////////////////////////////
//
// After filling the pump casing, reinstall and tighten the //
// fill plug. Do not attempt to operate the pump unless //
// all connecting piping is securely installed. Otherwise, //
// liquid in the pump forced out under pressure could cause //
// injury to personnel. //
// //
////////////////////////////////////

```

To fill the pump, remove the pump casing fill cover or fill plug at the top of the casing and add clean liquid until the pump is filled. Replace the fill cover or fill plug before operating the pump.

STARTING

Consult the operations manual furnished with the engine.

OPERATION

CAUTION

<p>Pump speed and operating condition points must be within the continuous performance range shown on the curve. See Section E, Page 1.</p>
---

Lines With a Bypass

Either a Gorman-Rupp automatic air release valve or a hand operated shutoff valve may be installed in a bypass line.

If a Gorman-Rupp automatic air release valve has been installed, close the throttling valve in the discharge line. The Gorman-Rupp valve will automatically open to allow the pump to prime, and automatically close when priming has been accomplished. After the pump has been primed, and liquid is flowing steadily from the bypass line, open the discharge throttling valve.

If a hand operated shutoff valve has been installed, close the throttling valve in the discharge line, and open the bypass shutoff valve so that the pump will not have to prime against the weight of the liquid in the discharge line. When the pump has been primed, and liquid is flowing steadily from the bypass line, close the bypass shutoff valve and open the discharge throttling valve.

Lines Without a Bypass

Open all valves in the discharge line and start the power source. Priming is indicated by a positive reading on the discharge pressure gauge or by a quieter operation. The pump may not prime immediately because the suction line must first fill with liquid. If the pump fails to prime within five minutes, stop it and check the suction line for leaks.

After the pump has been primed, partially close the discharge line throttling valve in order to fill the line slowly and guard against excessive shock pressure which could damage pipe ends, gaskets, sprinkler heads, and any other fixtures connected to the line. When the discharge line is completely filled, adjust the throttling valve to the required flow rate.

Leakage

No leakage should be visible at pump mating surfaces, or at pump connections or fittings. Keep all line connections and fittings tight to maintain maximum pump efficiency.

Liquid Temperature And Overheating

The maximum liquid temperature for this pump is 110°F. Do not apply it at a higher operating temperature.

Overheating can occur if operated with the valves in the suction or discharge lines closed. Operating against closed valves could bring the liquid to a boil, build pressure, and cause the pump to rupture or explode. If overheating occurs, stop the pump and allow it to cool before servicing it. Refill the pump casing with cool liquid.

WARNING

Do not remove plates, covers, gauges, pipe plugs, or fittings from an overheated pump. Vapor pressure within the pump can cause parts being disengaged to be ejected with great force. Allow the pump to cool before servicing.

Strainer Check

If a suction strainer has been shipped with the pump or installed by the user, check the strainer regularly, and clean it as necessary. The strainer should also be checked if pump flow rate begins to drop. If a vacuum suction gauge has been installed, monitor and record the readings regularly to detect strainer blockage.

---

---

### Pump Vacuum Check

With the pump inoperative, install a vacuum gauge in the system, using pipe dope on the threads. Block the suction line and start the pump. At operating speed the pump should pull a vacuum of 20 inches or more of mercury. If it does not, check for air leaks in the seal, gasket, or discharge valve.

Open the suction line, and read the vacuum gauge with the pump primed and at operating speed. Shut off the pump. The vacuum gauge reading will immediately drop proportionate to static suction lift, and should then stabilize. If the vacuum reading falls off rapidly after stabilization, an air leak exists. Before checking for the source of the leak, check the point of installation of the vacuum gauge.

### STOPPING

Never halt the flow of liquid suddenly. If the liquid being pumped is stopped abruptly, damaging shock waves can be transmitted to the pump and piping system. Close all connecting valves slowly. If the pump is driven by an engine, reduce the throttle speed slowly and allow the engine to idle briefly before stopping.

### CAUTION

If application involves a high discharge head, gradually close the discharge throttling valve before stopping the pump.

After stopping the pump, disconnect the spark plug wire to ensure that the pump will remain inoperative.

### Cold Weather Preservation

In below freezing conditions, drain the pump to prevent damage from freezing. Also, clean out any solids by flushing with a hose. Operate the pump for approximately one minute; this will remove any remaining liquid that could freeze the pump rotating parts.

If the pump will be idle for more than a few hours, or if it has been pumping liquids containing a large amount of solids, drain the pump, and flush it thoroughly with clean water. To prevent large solids from clogging the drain port and preventing the pump from completely draining, insert a rod or stiff wire in the drain port, and agitate the liquid during the draining process. Clean out any remaining solids by flushing with a hose.

PUMP TROUBLESHOOTING - SECTION D

WARNING

```

////////////////////////////////////
//
// Before attempting to open or service the pump:
//
// 1. Familiarize yourself with this manual.
// 2. Disconnect the engine spark plug wire to ensure
//    that the pump will remain inoperative.
// 3. Allow the pump to cool if overheated.
// 4. Vent the pump slowly and cautiously.
// 5. Close the suction and discharge valves.
// 6. Check the temperature before opening any covers,
//    plates, or plugs.
// 7. Drain the pump.
//
////////////////////////////////////
    
```

TROUBLE	POSSIBLE CAUSE	PROBABLE REMEDY
PUMP FAILS TO PRIME	Air leak in suction line. Lining of suction hose collapsed. Leaking or worn seal or pump gasket. Suction check valve or foot valve clogged or binding. Suction lift or discharge head too high. Strainer clogged.	Correct leak. Replace suction hose. Check pump vacuum. Replace leaking or worn seal or gasket. Clean valve. Check piping installation and install bypass line if needed. See INSTALLATION. Check strainer and clean if necessary.
PUMP STOPS OR FAILS TO DELIVER RATED FLOW OR PRESSURE	Air leak in suction line. Suction intake not submerged at proper level or sump too small. Lining of suction hose collapsed. Impeller or other wearing parts worn or damaged.	Correct leak. Check installation and correct as needed. Check submergence chart (Section B). Replace suction hose. Replace worn or damaged parts. Check that impeller is properly centered and rotates freely.

TROUBLE	POSSIBLE CAUSE	PROBABLE REMEDY
PUMP STOPS OR FAILS TO DELIVER RATED FLOW OR PRES-SURE(cont.)	<p>Impeller clogged.</p> <p>Pump speed too slow.</p> <p>Suction lift or discharge head too high.</p> <p>Leaking or worn seal or pump gasket.</p> <p>Strainer clogged.</p>	<p>Free impeller of debris.</p> <p>Check engine output; consult engine operation manual.</p> <p>Check piping installation and install bypass line if needed. See INSTALLATION.</p> <p>Check pump vacuum. Replace leaking or worn seal or gasket.</p> <p>Check strainer and clean if necessary.</p>
PUMP REQUIRES TOO MUCH POWER	<p>Pump speed too high.</p> <p>Discharge head too low.</p> <p>Liquid solution too thick.</p>	<p>Check engine output.</p> <p>Adjust discharge valve.</p> <p>Dilute if possible.</p>
PUMP CLOGS FREQUENTLY	<p>Discharge flow too slow.</p> <p>Suction check valve or foot valve clogged or binding.</p> <p>Discharge line clogged or restricted; hose kinked.</p>	<p>Open discharge valve fully to increase flow rate, and run engine at maximum governed speed.</p> <p>Clean valve.</p> <p>Check discharge lines; straighten hose.</p>
EXCESSIVE NOISE	<p>Cavitation in pump.</p> <p>Pumping entrained air.</p> <p>Pump or drive not securely mounted.</p> <p>Impeller clogged or damaged.</p>	<p>Reduce suction lift and/or friction losses in suction line. Record vacuum and pressure gauge readings and consult local representative or factory.</p> <p>Locate and eliminate source of air bubble.</p> <p>Secure mounting hardware.</p> <p>Clean out debris; replace damaged parts.</p>

PUMP MAINTENANCE AND REPAIR - SECTION E

MAINTENANCE AND REPAIR OF THE WEARING PARTS OF THE PUMP WILL MAINTAIN PEAK OPERATING PERFORMANCE.

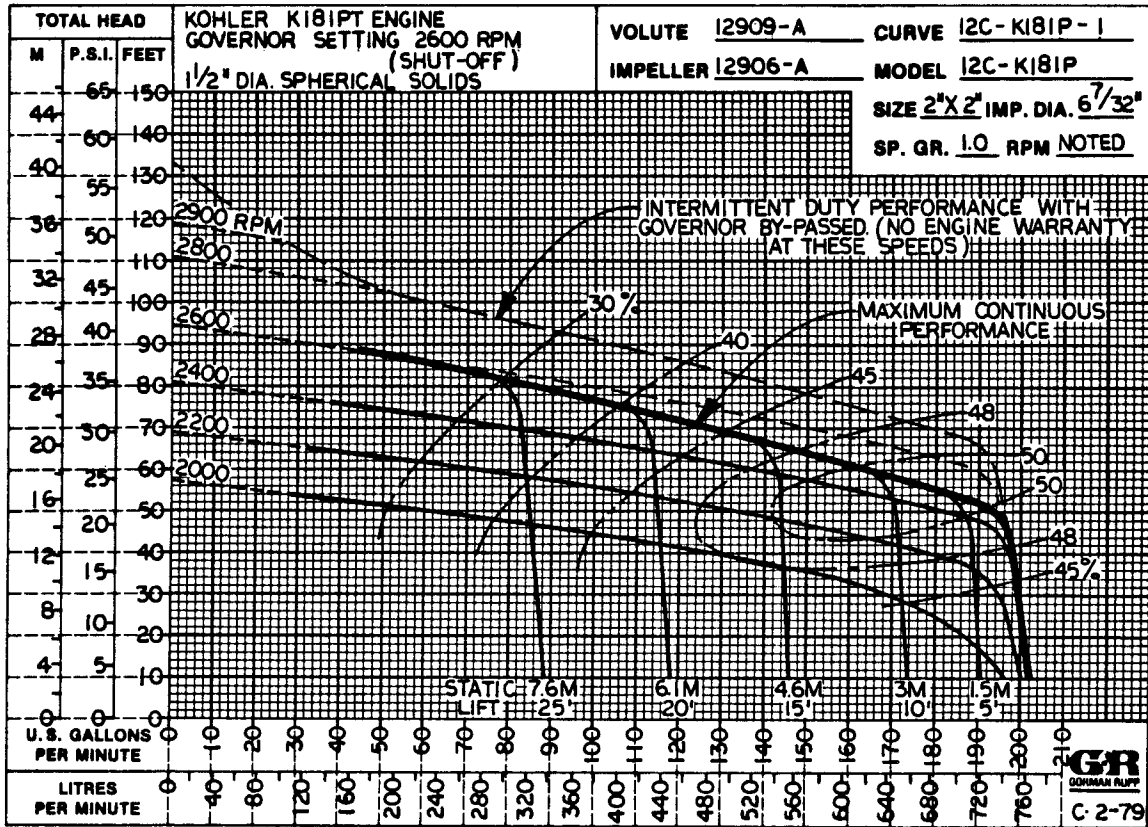

\*STANDARD PERFORMANCE FOR PUMP MODEL 12C2-K181P S/G

\*Based on 70°F clear water at sea level with minimum suction lift. Since pump installations are seldom identical, your performance may be different due to such factors as viscosity, specific gravity, elevation, temperature, and impeller trim.

If your pump serial number is followed by an "N", your pump is **NOT** a standard production model. Contact the Gorman-Rupp Company to verify performance or part numbers.

**CAUTION**

Pump speed and operating condition points must be within the continuous performance range shown on the curve. See Section E, Page 1.

SECTIONAL DRAWING

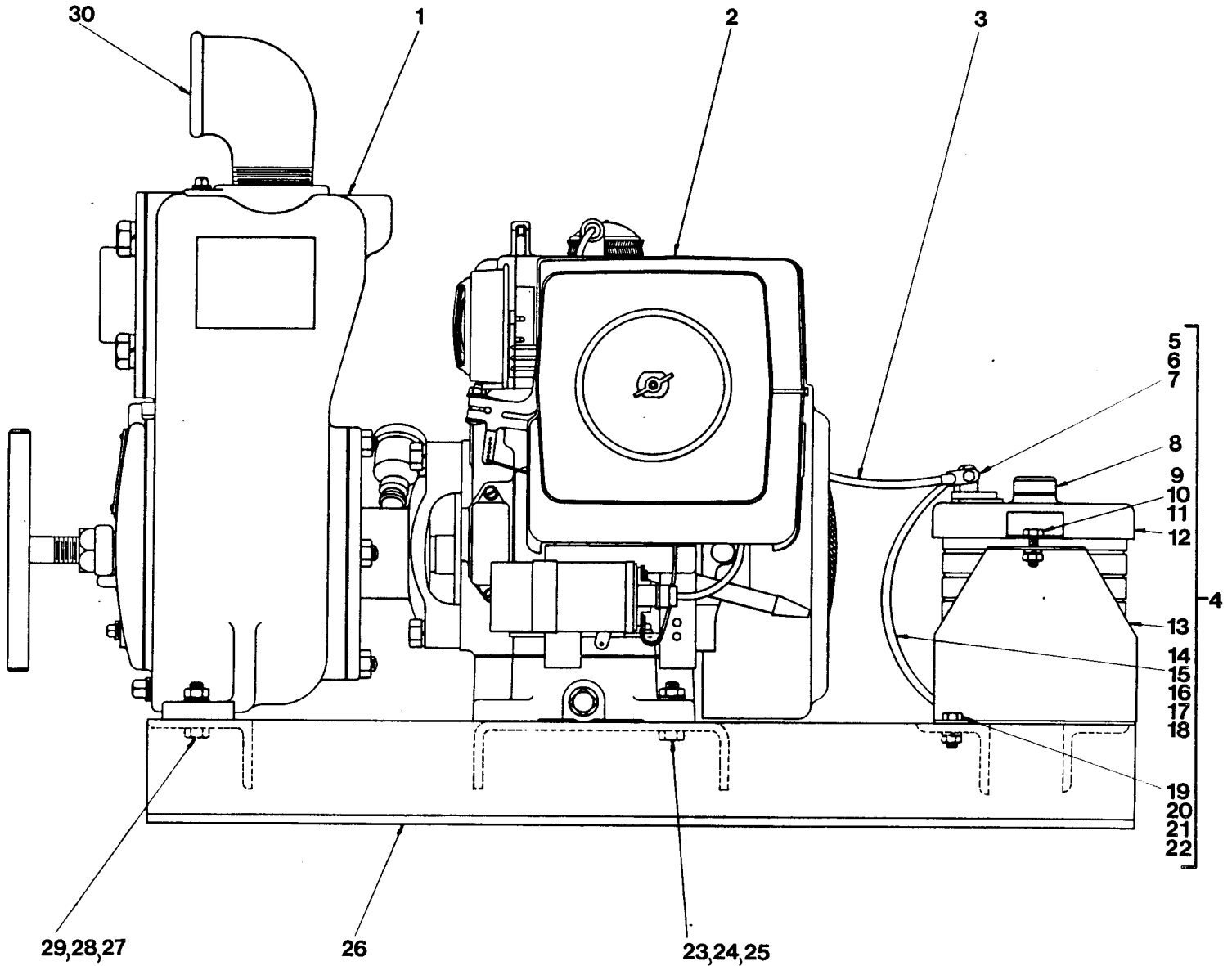

Figure 1. Pump Model 12C2-K181P S/G



**PARTS LIST**  
**Pump Model 12C2-K181P S/G**  
 (From S/N 860554 up)

If your pump serial number is followed by an "N", your pump is **NOT** a standard production model. Contact the Gorman-Rupp Company to verify part numbers.

ITEM NO.	PART NAME	PART NUMBER	MATL CODE	QTY
1	PUMP END ASSY (SEE FIGURE 2)	12C2	-----	1
2	KOHLER K181P S/G ENGINE	29127-083	-----	1
3	* CABLE ASSY	5795-DD	24040	1
4	BATTERY BOX ASSY	GRP40-05	-----	1
5	-HEX HD CAPSCREW	B00503	15991	1
6	-LOCKWASHER	J00005	15991	1
6A	-FLAT WASHER	K00005	15991	2
7	-HEX NUT	D00005	15991	1
8	* -BATTERY	S01680	-----	1
9	-HEX HD CAPSCREW	B00503	15991	2
10	-LOCKWASHER	J00005	15991	2
11	-HEX NUT	D00005	15991	2
12	-BATTERY BOX COVER	11870	24000	1
13	-BATTERY BOX	11281	24000	1
14	* -CABLE ASSY	5795-AS	24040	1
15	-HEX HD CAPSCREW	B00403	15991	1
16	-LOCKWASHER	J00004	15991	1
17	-FLAT WASHER	K00004	15991	1
18	-HEX NUT	D00004	15991	1
19	-HEX HD CAPSCREW	B00504	15991	1
20	-HEX HD CAPSCREW	B00503	15991	1
21	-LOCKWASHER	J00005	15991	2
22	-HEX NUT	D00005	15991	2
23	HEX HD CAPSCREW	B00605	15991	2
24	LOCKWASHER	J00006	15991	2
25	HEX NUT	D00006	15991	2
26	COMBINATION BASE	11140-A	24000	1
27	HEX HD CAPSCREW	B00605	15991	2
28	LOCKWASHER	J00006	15991	2
29	HEX NUT	D00006	15991	2
30	STREET ELBOW	RS00032	11990	1
NOT SHOWN:				
	WARNING DECAL	2613-FE	-----	1
	BATTERY TAG	6588-S	-----	1

\*INDICATES PARTS RECOMMENDED FOR STOCK

Above Serial Numbers Do Not Apply To Pumps Made In Canada.

CANADIAN SERIAL NO. .... AND UP

SECTIONAL DRAWING

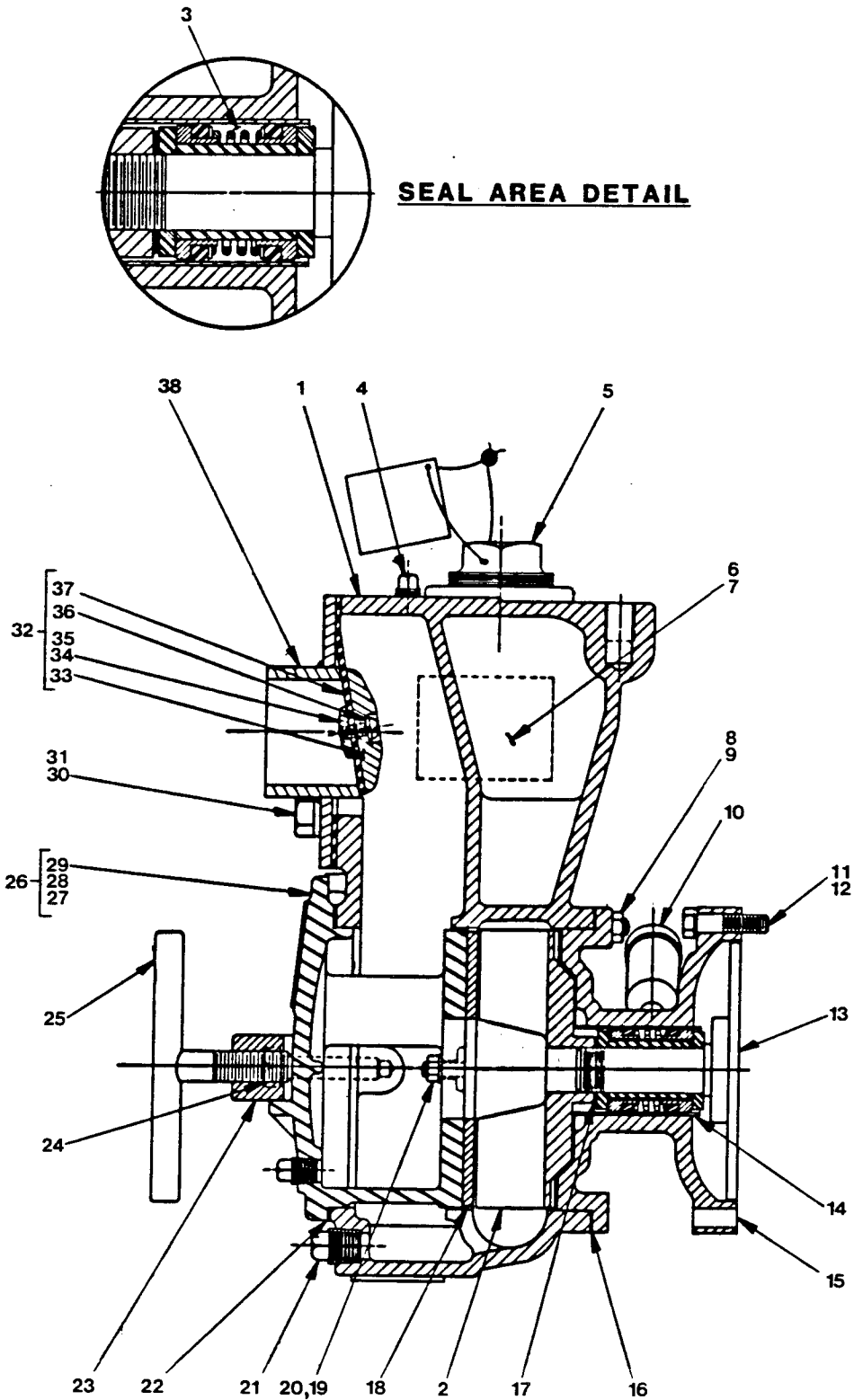

Figure 2. Pump End Assy 12C2-K181P S/G

PARTS LIST  
Pump End Assy 12C2-K181P S/G

ITEM NO.	PART NAME	PART NUMBER	MATL CODE	QTY
1	PUMP CASING	12909-A	10010	1
2	* IMPELLER	12906-A	11000	1
3	* SEAL ASSY	46521-013	-----	1
4	PIPE PLUG	P00004	11990	1
5	FILL PLUG ASSY	48271-069	-----	1
6	DRIVE SCREW	BM#04-03	15990	4
7	NAME PLATE	38818-021	13990	1
8	HEX NUT	D00006	15991	6
9	STUD	C00605	15991	6
10	GREASE CUP	S00036	-----	1
11	LOCKWASHER	J00006	15991	4
12	HEX HD CAPSCREW	B00606	15991	4
13	ENGINE CRANK SHAFT	NOT AVAILABLE		REF
14	* SEAL LINER	83	14080	REF
15	INTERMEDIATE ASSY	427-B	10010	1
16	* GASKET SET	229-G	18000	1
17	* IMPELLER SHIM SET	2-X	17090	REF
18	* WEAR PLATE ASSY	12911	15990	1
19	HEX NUT	D00006	15991	2
20	LOCKWASHER	J00006	15991	2
21	DRAIN PLUG	P00006	11990	1
22	* COVER GSKT	8616-G	19090	1
23	CLAMP BAR	12913	11000	1
24	MACHINE BOLT	A01008	15991	2
25	CLAMP SCREW	8618	24000	1
26	BACK COVER PLATE ASSY	42111-917	-----	1
27	-PIPE PLUG	P00004	11990	1
28	-WARNING PLATE	2613-EV	13990	1
	-DRIVE SCREW	BM#04-03	15990	4
29	-COVER	NOT AVAILABLE		1
30	HEX HD CAPSCREW	B01004	15991	4
31	LOCKWASHER	J00010	15991	4
32	CHECK VALVE ASSY	13465	-----	1
33	* -VALVE WEIGHT	19-A	10010	1
34	* -VALVE WEIGHT	1354	10010	1
35	-LOCKWASHER	J00004	17090	1
36	-RD HD MACHINE SCREW	X00403	17090	1
37	* -CHECK VALVE	13464	19070	1
38	FLANGE	13463	24000	1
NOT SHOWN:				
	STRAINER	9026	24000	1
	SUCTION STICKER	6588-AG	00000	1
	DISCHARGE STICKER	6588-BJ	00000	1

\*INDICATES PARTS RECOMMENDED FOR STOCK

**PUMP AND SEAL DISASSEMBLY AND REASSEMBLY**

This pump requires little service due to its rugged, minimum-maintenance design. However, if it becomes necessary to inspect or replace the wearing parts, follow these instructions which are keyed to the sectional views (see Figures 1 and 2) and the accompanying parts lists.

Most service functions may be performed by draining the pump and removing the back cover assembly. If major repair is required, the piping and/or engine must be disconnected.

Before attempting to service the pump, take precautions to ensure that the engine will remain inoperative. Close all connecting valves.

**WARNING**

```

////////////////////////////////////
//
// Before attempting to open or service the pump:
//
// 1. Familiarize yourself with this manual.
// 2. Disconnect the engine spark plug wire to ensure
// that the pump will remain inoperative.
// 3. Allow the pump to cool if overheated.
// 4. Vent the pump slowly and cautiously.
// 5. Close the suction and discharge valves.
// 6. Check the temperature before opening any covers,
// plates, or plugs.
// 7. Drain the pump.
//
////////////////////////////////////

```

**WARNING**

```

////////////////////////////////////
//
// Use lifting and moving equipment in good repair and with
// adequate capacity to prevent injuries to personnel or
// damage to equipment. Be sure chains or cables are posi-
// tioned so they will not damage the pump, and the load
// will be balanced. Suction and discharge hoses MUST be
// removed before lifting.
//
////////////////////////////////////

```

**Back Cover Removal**

**(Figure 2)**

The impeller, wear plate, check valve, and seal assembly can be serviced after the back cover assembly (26) has been removed. Before removing the assembly, remove the casing drain plug (21) and drain the pump. Clean and reinstall the drain plug.

Loosen the clamp screw (25) and clamp bar (23) securing the back cover. Pull the back cover and assembled wear plate (18) from the pump casing (1).

---

---

## Suction Check Valve Removal

### (Figure 2)

The check valve assembly (32) may be serviced by removing the suction flange (38). Remove the hardware (30 and 31) securing the suction flange to the pump casing, and pull the flange and assembled check valve from the suction port.

Inspect the check valve assembly for wear or damage, and replace parts as required.

## Impeller Removal

### (Figure 2)

Turn the cross arm on the automatic lubricating grease cup (10) clockwise until it rests against the cover (see Figure 4). This will prevent the grease from escaping when the impeller is removed.

To loosen the impeller (2), tap the vanes in a counterclockwise direction (when facing impeller) with a block of wood or a soft-faced mallet. Be careful not to damage the vane. Use caution when removing the impeller; tension on the seal spring will be released as the impeller is unscrewed.

Inspect the impeller, and replace it if cracked or badly worn. Slide the impeller adjusting shims (17) from the impeller shaft. For ease of reassembly, tag and tie the shims, or measure and record their thickness.

## Seal Disassembly

### (Figure 3)

Carefully remove the stationary and rotating seal elements, packing rings, seal spring, seal washers, and the shaft sleeve, using a stiff wire with a hooked end if necessary.

Inspect the seal liner (14, Figure 2) for wear or grooves which could cause leakage or damage to the seal packing rings. The seal liner is a press fit in the intermediate (15, Figure 2), and does not normally require replacement. If replacement is necessary, the intermediate must be removed. (See **Separating Intermediate From Engine**).

If no further disassembly is required, see **Seal Reassembly**.

## Pump Disassembly

### (Figure 2)

To service the intermediate, the pump end must be removed from the base. See Figure 1, and remove the hardware (27, 28, and 29) securing the pump casing to the base.

---

---

Remove nuts (8) securing the pump casing (1) to the intermediate (15), and remove the pump casing. If shims have been used under the mounting feet to level the pump casing, tag and tie these shims. Remove the grease cup (10) from the intermediate.

### Separating Intermediate From Engine

#### (Figure 3)

If necessary to separate the intermediate from the engine, remove the hardware (11 and 12) securing the intermediate (15) to the engine. Separate the assemblies by pulling the intermediate straight away from the engine.

Inspect the bore of the seal liner (14) for wear or grooves which might cause leakage or damage to the seal packing rings. If the seal liner must be replaced, position the intermediate on the bed of an arbor (or hydraulic) press and use a new sleeve to force the old one out. After the new liner is properly installed, a 1/4 inch diameter hole must be drilled through it to permit the flow of lubricant to the seal assembly. **Be careful** to center the drill in the threaded grease pipe hole and not damage the threads. Deburr the hole from the inside of the seal liner after drilling.

### Securing Intermediate To Engine

#### (Figure 2)

Secure the intermediate to the engine using the hardware previously removed. Reinstall the automatic grease cup.

#### NOTE

It is recommended that the seal and impeller be reassembled at this time. It is best to adjust the back impeller clearance before installing the pump casing. See **Impeller Reassembly And Adjustment**.

Install the same thickness of pump casing gaskets (16) as previously removed from the pump casing studs and secure the pump casing to the intermediate. Be sure to reinstall any leveling shims used under the pump casing mounting feet before installing the base mounting hardware.

#### NOTE

The front impeller clearance must be adjusted after pump casing and back cover are fully reassembled by adding or subtracting pump casing gaskets (16). Do not secure the pump casing to the base until this operation is done.

Seal Reassembly

(Figure 2 and 3)

Clean the seal cavity and shaft with a cloth soaked in fresh cleaning solvent.

WARNING

```

////////////////////////////////////
//
// Most cleaning solvents are toxic and flammable. Use //
// them only in a well-ventilated area free from excessive //
// heat, sparks, and flame. Read and follow all prec- //
// autions printed on solvent containers. //
// //
////////////////////////////////////

```

The seal is not normally reused because wear patterns on the finished faces cannot be realigned during reassembly. This could result in premature failure. If necessary to reuse an old seal in an emergency, **carefully** wash all metallic parts in fresh cleaning solvent and allow to dry thoroughly.

Handle the seal parts with extreme care to prevent damage. Be careful not to contaminate precision finished faces; even fingerprints on the faces can shorten seal life. If necessary, clean the faces with a non-oil based solvent and a clean lint free tissue. Wipe **lightly** in a concentric pattern to avoid scratching the faces.

Inspect the seal components for wear, scoring, grooves, and other damage that might cause leakage. Clean and polish the shaft sleeve, or replace it if there are nicks or cuts on either end. If any components are worn, replace the complete seal; **never mix old and new seal parts.**

If a replacement seal is being used, remove it from the container and inspect the precision finished faces to ensure that they are free of any foreign matter.

To ease installation of the seal, lubricate the O-rings and seal liner with water or a very **small** amount of oil, and apply a drop of light lubricating oil on the finished faces. Assemble the seal as follows, (see Figure 3).

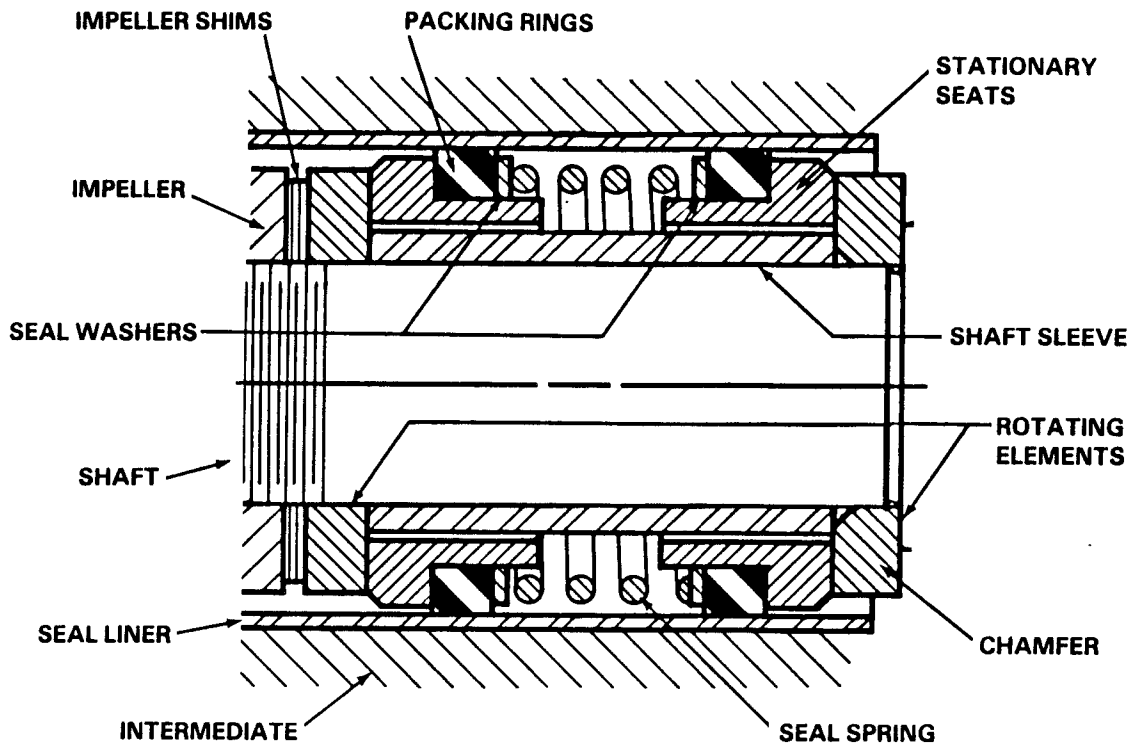

Figure 3. 46521-013 Seal Assembly

#### CAUTION

This seal is not designed for operation at temperatures above 110°F. Do not use at higher operating temperatures.

Inspect the impeller shaft for burrs or sharp corners, and remove any that exist. Replace the seal liner (14) if wear or grooves exist which could cause leakage or damage to the seal packing rings.

#### NOTE

The intermediate must be removed to install a new seal liner. See **Separating Intermediate From Engine** for specific instructions on seal liner installation.

Position the inboard rotating element on the shaft with the chamfered side facing the impeller, and slide it on until fully seated. A push tube cut from a length of plastic pipe would aid in this installation. The I.D. of the push tube should be approximately the same as the I.D. of the spring.



---

---

Subassemble the inboard stationary seat, packing ring, and spring washer and slide the unit onto the shaft spacer sleeve. Slide this subassembly into the lubricated seal liner.

Install the spacer sleeve and spring.

Subassemble the outboard stationary seat, packing ring, and spring washer. Press this unit into the lubricated seal liner.

Install the outboard rotating element with chamfered side facing the impeller.

Lubricate the seal as indicated in LUBRICATION, after the impeller has been installed.

### Impeller Reassembly And Adjustment

#### (Figure 2)

Inspect the impeller, and replace it if cracked or badly worn.

Slide the same number of impeller adjusting shims (17) as previously removed onto the shaft and screw the impeller on until tight.

A clearance of .020 to .040 inch between the impeller and the seal plate is necessary for maximum pump efficiency. Measure this clearance, and add or remove impeller shims until it is reached.

#### NOTE

If the pump has been completely disassembled, install a new pump casing gasket set and secure the pump casing to the intermediate at this time.

A clearance of .008 to .015 inch between the impeller and the wear plate is also recommended for maximum pump efficiency. This clearance must be set after installing the back cover, by adding or removing gaskets in the pump casing gasket set until the impeller binds against the wear plate when the shaft is turned. After the impeller binds, add .012 inch of gaskets.

### Suction Check Valve Installation

Inspect the check valve assembly, and replace any parts that are badly worn.

Position the check valve assembly over the suction port with the large weight toward the inside of the pump. Install and secure the suction flange.

---

---

## Back Cover Installation

### (Figure 2)

Inspect the wear plate (18) and replace it if badly worn or grooved. To remove the wear plate, disengage the hardware (19 and 20).

Clean any scale or debris from the back cover shoulder and pump casing which might prevent a good seal. Replace the back cover gasket (22) and slide the back cover assembly into the pump casing. Be sure the wear plate does not bind against the pump casing.

### NOTE

To ease future disassembly, apply a film of grease or 'Never-Seez' on the back cover shoulder, or any surface which contacts the pump casing. This action will reduce rust and scale build-up.

Secure the back cover assembly by installing the clamp bar and tightening the cover clamp screw. **Do not** over tighten the clamp screw; it should be just tight enough to ensure a good seal at the back cover shoulder.

## Final Pump Reassembly

### (Figure 1)

**Be sure** the pump is secured to the base and engine.

Install the suction and discharge lines, and open all valves. Make certain that all piping connections are tight and properly supported.

**Be sure** the pump end and engine have been properly lubricated, see LUBRICATION.

Fill the pump casing with clean liquid and tighten the fill plug.

Refer to **OPERATION**, Section C, and start the pump.

## LUBRICATION

### Seal Assembly

Fill the grease cup through the grease fitting with a good grade of No. 2 lithium base grease until grease escapes from the relief hole. Turn the grease cup arm counterclockwise until it is at the top of the stem; this will release the spring to apply grease to the seal (see Figure 4).

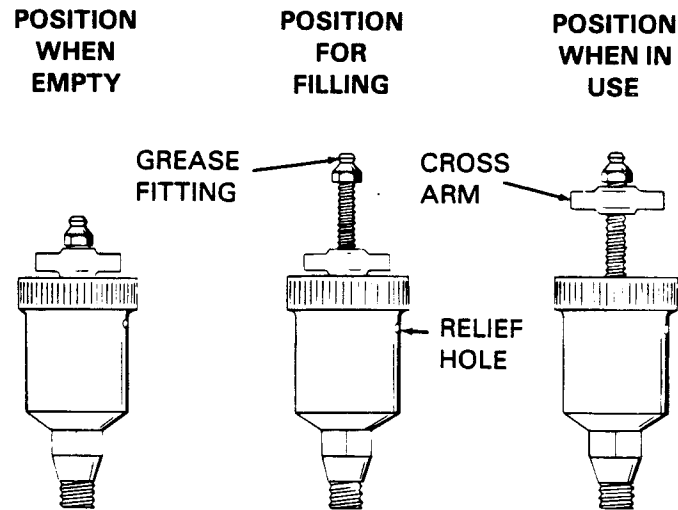

Figure 4. Automatic Lubricating Grease Cup

## Engine

Consult the literature supplied with the engine, or contact your local engine representative.





**For U.S. and International Warranty Information,  
Please Visit [www.grpumps.com/warranty](http://www.grpumps.com/warranty)  
or call:  
U.S.: 419-755-1280  
International: +1-419-755-1352**

**For Canadian Warranty Information,  
Please Visit [www.grcanada.com/warranty](http://www.grcanada.com/warranty)  
or call:  
519-631-2870**